

MA4008

ENERGY-EFFICIENT, MULTI-FUNCTION
80-WATT MIXING AMPLIFIER WITH
DUAL 70/100 V AND 4 Ω OUTPUTS

EUROCOM Installed Sound

MA4008 Features:

- Multi-function 80-Watt mixing amplifier with dual 70/100 V and 8 Ω outputs, designed for continuous operation in distributed music, paging and AV applications
- State-of-the-art, energy-saving Switch-Mode Power technology with up to 70% power efficiency drastically reduces energy cost
- 2 transformerless, cool-running Class-D amplifiers simultaneously drive 70/100 V and 8 Ω loads with adjustable Balance control
- 8 Mic/Line inputs on Euroblock, XLR/TRS and RCA connectors, each with switchable Mic/Line and Phantom Power, individual Trim control and post-trim input level LED
- Inputs 1-8 individually assignable to Zone 2/MOH output; Aux inputs 5-8 individually assignable to Main Mix
- Dedicated page input accepts telephone or paging microphone and features priority muting across all inputs
- Wired Remote volume, power and mute control connector
- Individual front panel input Level plus Lo and Hi Main EQ controls
- Auto-dimming control illumination, dual channel VU meter, Power switch, and dual-function indicator ring surrounding Master volume control
- Main mix output on Euroblock connector with selectable 70/100 V and 4 Ω outputs
- Recording output and Zone 2/MOH assignable output with independent gain control
- 2 Preamp Out/Amp In processing loops for each 70/100 V and 8 Ω output

Product Overview:

The EUROCOM MA4008 professional mixer-amplifier offers extraordinary flexibility and ease-of-use in an integrated rack-mountable system that is an ideal match for installations such as restaurants, bars, stores, sports clubs, spas, and houses of worship. Incorporating BEHRINGER's exclusive DualDrive technology, the MA4008 is powered by two independent mono amplifiers, one with a high impedance output that may be set to either 70 or 100 V, and the other with a standard low-impedance output. This uniquely versatile configuration enables easy installation and setup of hybrid multi-zone systems combining distributed and low-impedance speakers.

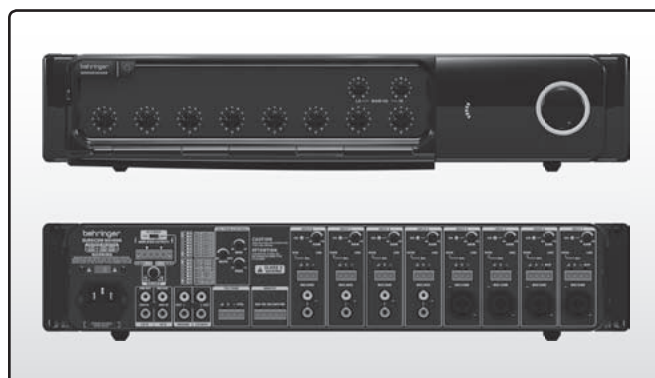

MA4008 Technical Specifications:

Audio Inputs

Mic / Line inputs 1 & 2

Type	2 x XLR / ¼" TRS combo jacks 2 x 4-pin Euroblock in parallel
Impedance	Mic: -50 to 0 dBV, 600 Ω Line: -27 to 0 dBV, 600 Ω Electronically balanced

Mic / Line inputs 3 & 4

Type	2 x XLR / ¼" TRS combo jacks 2 x 3-pin Euroblock in parallel
Impedance	Mic: -50 to 0 dBV, 600 Ω Line: -27 to 0 dBV, 600 Ω Electronically balanced

Inputs 5 - 8

Type	4 x 3-pin Euroblock, electronically balanced
Impedance	Mic: -50 to 0 dBV, 600 Ω Line: -27 to 0 dBV, 600 Ω

Auxiliary

Type	4 x RCA stereo summed
Impedance	-10 dBV, 10 kΩ, unbalanced

Tel / Page input

Impedance	1 x 4-pin Euroblock Mic: -50 to 0 dBV, 600 Ω Line: -27 to 0 dBV, 600 Ω
-----------	--

Power amp input

Impedance	1 x dual RCA jack 0 dBV, 600 Ω, unbalanced
-----------	---

Phantom power

24 VDC, switchable Inputs 1–8
and Tel/Page



MA4008 ENERGY-EFFICIENT, MULTI-FUNCTION 80-WATT MIXING AMPLIFIER WITH DUAL 70/100 V AND 4 Ω OUTPUTS

EUROCOM Installed Sound

MA4008 Overview continued:

Designed for easy operation by non-technical personnel, the MA4008 features a clear, intuitive front panel. Level controls are provided for all inputs, as are high and low EQ settings to optimize the sound for any environment. The front-panel master volume knob is surrounded by an indicator ring that glows yellow when the unit is powered and flashes red at the onset of clipping. A VU meter is provided to indicate amplifier signal level.

The MA4008 includes eight source-switchable channels for balanced or unbalanced input from line-level sources or microphones, either dynamic or condenser. All channels accept input via Euroblock connectors (six 3-pin and two 4-pin with mute terminals) and have both a signal LED and a level trim. Inputs 1-4 also have XLR/TRS (¼-inch) combination jacks, while inputs 5-8 each have a pair of RCA jacks, summed internally to mono, for sources such as CD/MP3 players, cable boxes, and radio/TV tuners. Additional connections provided via Euroblock include a 4-pin for telephone paging, a 5-pin for remote control, and a single 4-pin for both high- and low-Z outputs to loudspeakers. A Zone 2/Music on Hold mix, including input channels assigned via the Zone 2/MOH DIP switches, is split to a pair of RCA jacks that may be used to feed a supplemental sound reinforcement system. Another set of RCA jacks outputs a recording feed (pre-master main mix). Line-level effects send and receive, used to insert external processing such as dynamics or EQ is also provided for each of the two amps using RCA jacks.

Extensive back-panel control allows the installer to rapidly customize the MA4008 to the needs of a specific installation. Switches are provided for mains voltage (115 or 240 VAC) and high-Z output (70 or 100 V). A Balance control adjusts the relative levels of the two power amplifiers. DIP switches handle Zone 2/MOH assignments, enable inputs 5-8 in the main mix, enable external processing inserts, and select the paging input. Trim pots adjust the Zone 2/MOH output level, the paging input level, and mute depth, which determines the degree of attenuation during automatic ducking of background audio.

MA4008 operation is both cool and energy-efficient thanks to transformerless Class-D amplifiers that utilize switch-mode power supplies. The low-Z amplifier delivers 80 W RMS into 8 Ω, while the high-Z amplifier delivers 80 W RMS

at 70 or 100 V. Each amplifier is protected against DC and thermal overload, and built-in automatic limiting prevents overload, clipping, and distortion.

Combining remarkable versatility with practical functionality and straightforward operation, the MA4008 is a superb mixer-amplifier for small-to-mid-sized commercial installations, achieving unprecedented value in its class.

MA4008 Technical Specifications continued:

Audio Outputs

Amplifier output	1 x 4-pin female Euroblock
LO-Z	2 terminals @ 8 Ω
HI-Z	2 terminals @ 70 V / 100 V, switchable
Output regulation	< 2 dB, no load to full load
Preamp output	1 x dual RCA jack
Impedance	0 dBV, 600 Ω, unbalanced
Z2 / Mon output	1 x dual RCA jack
Impedance	0 dBV, 600 Ω, unbalanced
Record output	1 x dual RCA jack
Impedance	0 dBV, 600 Ω, unbalanced

Amplifier

Amplifier channels	LO-Z: 1 x 4 Ω, minimum HI-Z: 1 x 70 / 100 V, switchable
Power output LO-Z 1 % THD, 1 kHz sine wave	80 W RMS @ 8 Ω
Min. impedance	-
Power output HI-Z 1 % THD, 1 kHz sine wave	80 W RMS @ 70 V 80 W RMS @ 100 V
Min. impedance	62 Ω @ 70 V 125 Ω @ 100 V

System Information

Dynamic range	Mic: 65 dB Line: 80 dB
THD + N	0.5% @ 1 kHz, rated output
Frequency response	50 Hz - 18 kHz, +/- 2 dB
Tone controls	Low: +/- 12 dB @ 100 Hz High: +/- 12 dB @ 10 kHz

MA4008 ENERGY-EFFICIENT, MULTI-FUNCTION 80-WATT MIXING AMPLIFIER WITH DUAL 70/100 V AND 4 Ω OUTPUTS

EUROCOM Installed Sound

MA4008 Technical Specifications continued:

Control Connections

Remote	1 x 5-pin Euroblock connector
Volume	10 kΩ linear-taper potentiometer
Power	+5 VDC voltage make contact input; no open voltage
Mute	No-voltage make contact input; open voltage 5 VDC Short circuit: < 10 mA
DC Power	+5 VDC, 100 mA Current limited, short-circuit protected
Tel / Page	1 x 4-pin Euroblock, 1 terminal
Mute	No-voltage make contact input; open voltage 24 VDC Short circuit: < 10 mA
Inputs 1 & 2	2 x 4-pin Euroblock, 1 terminal each
Mute	No-voltage make contact input; open voltage 24 VDC Short circuit: < 10 mA

Indicators

Power	LED ring illumination (Yellow)
Overload / protection	LED ring indication (Red)
Output level	LED VU output meter (Yellow and Red while clipping)

Power Supply (Fuses)

Mains voltage	Switchable, 115/230 VAC, 60/50 Hz
Fuse	T 5 AH 250 V / T 2.5 AH 250V
Power efficiency	68% (max.)
Power consumption	52 W @ idle 70W @ 1/8 power 113 W @ 1/3 power 234 W @ full power
Mains connector	Standard IEC receptacle

Dimensions / Weight

Dimensions (H x W x D)	3.5 x 17 x 16" / 88 x 432 x 406 mm
Weight	10.2 lbs / 4.6 kg

Dimensional Drawings:

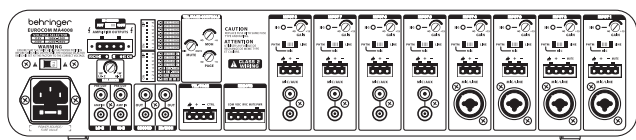

REAR

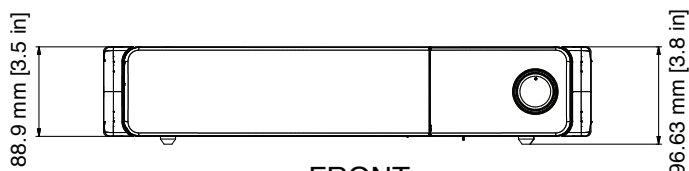

FRONT

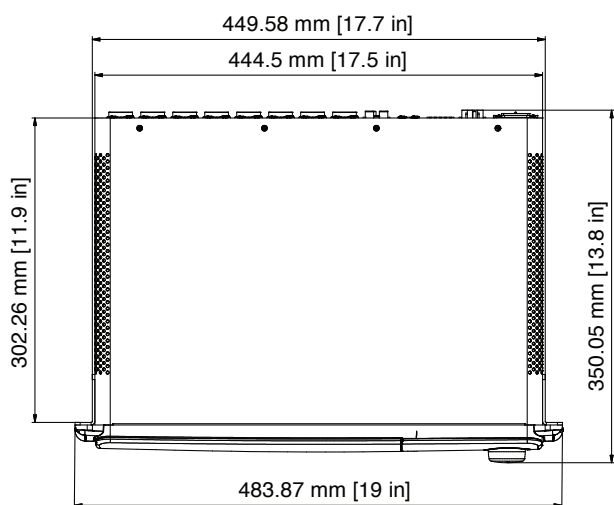

TOP

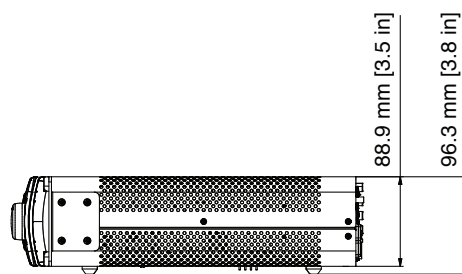

SIDE

MA4008 ENERGY-EFFICIENT, MULTI-FUNCTION 80-WATT MIXING AMPLIFIER WITH DUAL 70/100 V AND 4 Ω OUTPUTS

EUROCOM Installed Sound

Dimensional Drawings:

The mixer-amplifier shall be of rack-mountable multi-input design with built-in paging functions and two mono transformerless Class D power amplifiers with switch-mode power supplies, one low-Z and one high-Z (70/100 V) for distributed speaker systems.

Controls and indicators shall include the following:

- Power switch to turn the unit on and off
- Power Indicator displaying amber logo when unit is powered
- Master Volume knob for setting overall volume
- Indicator ring for power (yellow) and clipping (flashing red)
- VU meter to indicate amplifier signal level
- HI EQ/LO EQ knobs to adjust the overall treble and bass
- Input level knobs (1-8) to set the relative level of each input
- Mains voltage switch to select 115 or 240 VAC
- High-Z output switch to select 70 or 100 V operation
- Phantom/Mic/Line switch (8) to select mode of each input channel
- Signal LED (8) for each input to indicate presence of signal
- Gain screw pot (8) for each input to trim input gain
- Z2/MOH DIP switches (8) to assign inputs to the Z2/MOH out
- Function DIP switches (8) to assign inputs 5-8, enable signal inserts, and set the page input for line, mic, or phantom-power mic
- Page input screw pot to adjust paging input level
- Mute depth screw pot to set ducking of aux inputs during pages
- Z2/MOH output screw pot to adjust the level of the Z2/MOG feed
- Balance screw pot to adjust the relative output of the two amps

Connections to the mixer-amplifier shall include:

- Mic/Line inputs on four XLR/TRS (¼-inch) combination jacks, six 3-pin Euroblock connectors, and two 4-pin Euroblock connectors with mute terminal
- Aux inputs on four pairs of unbalanced line-level RCA jacks, each summed to mono
- Tel/Page input on a 4-pin Euroblock connector
- Output for both high- and low-Z on a 4-pin Euroblock connector
- Z2/MOH line-level output on a pair of RCA jacks
- Record line-level output on a pair of RCA jacks
- Effects inserts on RCA jacks (send and receive for each amp)
- Remote control input on 5-pin Euroblock connector
- AC power on IEC jack

Protections incorporated into the amplifier shall include automatic limiting and independent DC and thermal overload protection.

Performance criteria met by the mixer-amplifier shall include:

- RMS power output (1 kHz @ 1% THD) for the low-Z amp of 80W (8 Ohms) and for the high-Z amp of 80/80 W (100/70 V)
- Frequency Response of 50 Hz-18 kHz, +/- 2 dB
- Dynamic range of 65 dB for Mic and 80 dB for Line
- Distortion (THD+N, 1 kHz) of 0.5% at rated output

AC Power requirements of the mixer-amplifier shall be:

- Mains voltage of 115 or 230 VAC at 50~60Hz
- Power consumption ranging from 52 W idle to 234 W full power
- Power efficiency of 68% (max)

Physical characteristics of the mixer-amplifier shall be:

- Height x Width x Depth of 3.5 x 17 x 16 in (88 x 432 x 406 mm)
- Net weight of 10.2 lbs (4.6 kg)

The mixer-amplifier shall be the BEHRINGER EUROCOM MA4008.