



PM5

Handheld Condenser Microphone Owner's Manual

Introduction

Thank you and congratulations on your purchase of the Miktek PM5, Performance Series handheld stage microphone. You work hard to give a better than average performance, so you demand a better than average microphone to reproduce the sound of your voice. Miktek Performance Series handheld microphones offer way above average sound and build quality impressing the most discriminating engineers and artists. Featuring cutting edge capsule designs that are perfectly matched to Miktek's proprietary output transformers; the Performance Series Microphones produce a modern, yet truly classic sound, well suited to today's contemporary performers.

In the following sections of this manual you will find a description of the PM5's features, step-by-step set-up and operating instructions along with detailed specifications. In addition, we've also included some basic miking fundamentals for typical live sound and recording applications. To some of us these may seem quite basic. However, at Miktek we want to encourage young or new engineers to use our microphones, or at least to read our manuals and learn something about recording and live sound. We know you're serious about your sound because you purchased an outstanding audio instrument, and at Miktek, we're serious about providing superior products and service to our customers. We appreciate your patronage and hope you enjoying using your microphones as much as we enjoy making them.

Sincerely,

Michael Ketchell - Managing Director

PM5 Features

- Studio Quality Handheld Condenser
- MK5a 0.5-inch Cardioid Capsule with 5-micron Mylar, Evaporated Gold Diaphragm
- AMI T5 Transformer
- Hand-selected Transistors
- Packaged Protective Case and Mic Clip

Description

The Miktek PM5 cardioid, condenser microphone brings the sound of a high-end studio condenser to vocalists for live stage use. Sharing the capsule, electronics and output transformer of the Miktek PM5 small diaphragm condenser, the PM5 is a truly world-class mic that offers

detail and nuance. The PM5's frequency response is extremely linear, with rich lows, a present yet sweet mid-range, and airy highs that please artists and engineers alike. In fact, the PM5 is perfectly at home in the recording studio for miking acoustic guitar, piano and as drum overheads. The PM5 employs a multistage windscreen to help ensure a minimum amount of p-popping. The steel grill and die cast body ensure durability and reliability night after night. An ultra sleek, black finish with stainless steel appointments make the PM5 an attractive complement to any stage setting.

Understanding Polar Patterns

Perhaps the most important aspect of using your PM5, or any other microphone, is to understand its polar pick up pattern. Every microphone has a characteristic polar pattern that determines how well it accepts or rejects signal coming from various areas around the microphone capsule. There are many types and variations of polar patterns but the three most common are omnidirectional, bidirectional or figure-eight and unidirectional or cardioid. Omnidirectional microphones pick up sound from everywhere, producing the same frequency response regardless of where the sound source originates (in front of the mic, behind it, to the side, etc.). A bidirectional or figure-eight microphone picks up sound directly from the front and back while rejecting the sound at the sides. In contrast, cardioid mics are specifically designed to accept the sound coming from directly in front, and to reject sound coming from behind or from the sides. The PM5's capsule provides a super cardioid polar pattern with an even tighter response. While Omni and Bidirectional microphones are very useful for a variety of applications, the majority of miking situations in live sound applications require unidirectional or cardioid microphones. When positioned correctly, the cardioid pattern allows you to pick up more of the sound you want and less of the sound you don't want. In live sound situations, the polar pattern greatly determines how prone a particular microphone is to inducing feedback. Feedback is that nasty howling sound that occurs when a mic is placed too close to a loudspeaker—the signal from the loudspeaker is fed into the mic, then into the loudspeaker, then into the mic, over and over. The super cardioid pick-up pattern allows for better separation of instruments on stage and more control over feedback in live sound reinforcement.

Stand Mounting the PM5

The PM5 can be mounted to any standard microphone stand using the included mic stand holder. If you are using a US standard 5/8-inch mic stand, remove the Euro adapter by unscrewing it from the mic holder. Slide the microphone into the holder from the rear to the front with a downward motion until it snaps into place.

Microphone Placement

To help maximize the quality of your performance, you must pay careful attention to the placement of your PM5, and specifically, how it is positioned for the instrument or vocalist that you're miking. As you become more experienced in miking techniques, you'll quickly realize the microphone placement is critical to getting the sound you want while maximizing gain before feedback. When placing the mic around any instrument or sound source, take notice of the position of the front of house and monitor loudspeakers. In general, it's good practice to set the microphone behind the main or front of house PA speakers to avoid feedback from those speakers. Also, position the microphone in front of a monitor loudspeaker within a 110 degree arch as shown in the diagram below. As you're changing the microphone's position, be sure to check that the mic input is still set to a good level without clipping, as described in the previous section.

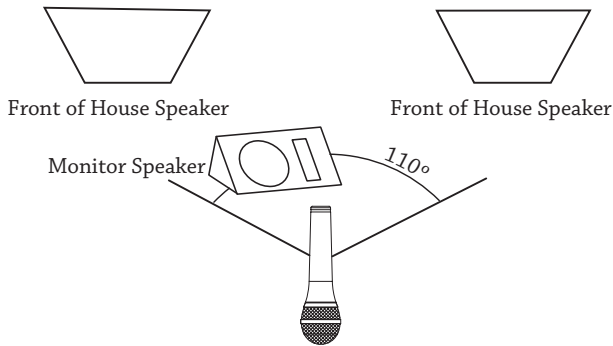

Powering the PM5

Since the PM5 is a condenser microphone it needs to be operated by connecting it to a 48 volt Phantom power source. Most quality mixers, outboard mic pres and DAW mic channels have Phantom power available as a standard feature. You can also use an external phantom supply, if necessary. Since most mixers and outboard mic pres have a dedicated switch to engage the phantom power, be sure to check that the Phantom power is on. Once the Phantom power source is turned on, the PM5 receives the Phantom power directly from a mic cable. Note: Without Phantom power the PM5 will not pass audio.

Setting Up the Signal Level

In order to get a good signal, first be sure that the PM5 is connected to a mixer or recorder input that is microphone level. Most quality mixers, mic pre's and recorders provide microphone inputs with a mic trim ("Trim" AKA Mic Gain or Level) control. The purpose of the mic trim control is to set a good signal level and minimize any noise associated with the mic inputs electronics. A good mic pre will also have a Clip or Peak LED to show you when the input is at overload;

the level which distortion begins to occur. To set a good clean level, set the PM5 up in front of the desired sound source and slowly turn up the mic trim until you see the Clip LED light up. Then, turn the trim control down until the LED does not light any more. On most microphone inputs, the best setting is when the trim control is turned up as high as possible without lighting the PEAK LED.

The Proximity Effect

All cardioid or uni-directional microphones exhibit a phenomenon known as "proximity effect". The proximity effect is the increase in low frequency response a microphone exhibits as it is moved closer to the sound source. Vocalist tend to love this effect since when they get really close to the mic they get the "FM radio", big bass sound. A good vocalist with good mic technique will use the proximity effect to adjust their tonal response in real time. The key to developing the best mic technique is experimentation, along with awareness of the general principle that, the closer your PM5 is to a signal source, the greater the bass response. The proximity effect's bass lift is caused by the amount of pressure present at the ports that are used to create the directional pattern. Since omnidirectional microphones do not have ports, they do not have proximity effect.

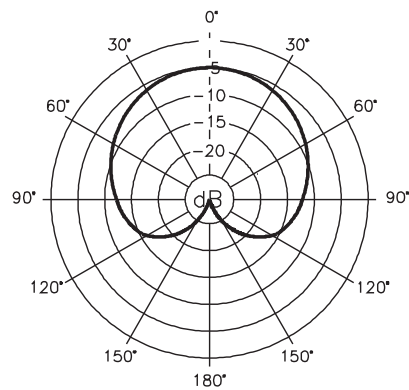
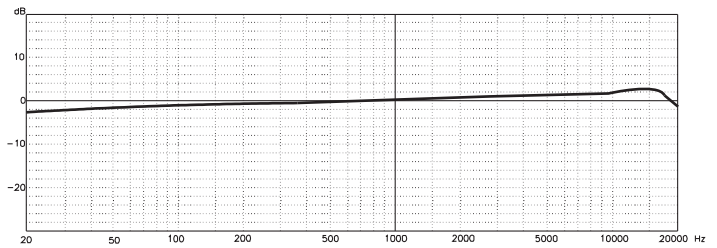

PM5 Specifications

- Type Condenser
- Polar Pattern: Cardioid
- Frequency Response: 20Hz - 20KHz
- Impedance: 200 Ohms
- Sensitivity -35dBV/Pa
- Low Cut Filter 80 Hz
- Length: 7.1 inches
- Width: 2.0 inches
- Depth: 2.0 inches
- Net Weight: 0.65 pounds