

CEK-8M

Quality Features

- Surface baffle mounts an 8" speaker (order separately).
- Long-lasting steel assembly with slope front design is ideal for installation in classrooms, offices and retail establishments.
- Mounting plate facilitates installation to a single gang or 4 inch square electrical box.

Description

Slope-front Wall Baffle Model CEK-8M is an attractive assembly for surface-mount applications where a long-lasting steel assembly is the preferred characteristic for the paging and music speaker.

The baffle is designed to mount an 8" speaker and measures 13.75"H x 10.378"W with a front-to-rear depth of 5.75"D at the top and 4.278"D at the bottom (see drawings on page 2). The housing is 20 gauge welded steel finished in white powder epoxy. The perforated grille is 20 gauge steel and is welded from the rear for a clean outside appearance. Additionally, studs are welded on the interior for mounting a standard 8" speaker such as Lowell's 805 (12W) or 810 (15W) drivers (order separately).

The rear mounting plate features Lowell's universal mounting pattern for installation to a 4" square, 4" octagon, 2-gang or 1-gang E.O. Box. A grommet with .562" Diameter hole is also located in the center of the plate for wire access.

For installation convenience, the mounting plate installs to the wall first and then the baffle with mounted speaker (order separately) installs to the plate and secures from the side using two screws on each side.

A & E Specifications

The baffle for surface mounting 8" speakers shall be Lowell Model CEK-8M slope-front wall baffle. The baffle housing shall be constructed of 20 gauge welded steel and finished in white powder epoxy. The perforated grille shall be 20 gauge steel and welded from the rear. The mounting plate shall include a universal E.O. box mounting pattern with grommet and a .562" diameter hole for wire access. The wall baffle shall measure 13.75"H x 10.348"W with a front-to-rear depth of 5.75" at the top and 4.278" at the bottom. It shall include welded studs and assembly hardware for mounting standard EIA 8" speaker.

WALL BAFFLE SPECIFICATIONS

Model	Description	Mounts Speaker*	Style	Material	Dimensions	Mounts
CEK-8M	Wall Baffle	8"	Slope-front	Steel White finish	13.75"H x 10.348"W x 5.75" Proj. (top) x 4.278" Proj. (bottom)	E.O. Box

*Order speaker separately. Lowell offers 8" speaker Models 805 (12W), 810 (15W) and CT830 coaxial (20W) drivers.



CEK-8M

Surface Baffle for 8" Speakers

A
U
D
I
O

12"/10"
Speakers &
Accessories

8"
Speakers &
Accessories

6"
Speakers &
Accessories

4"
Speakers &
Accessories

Horn
Speakers &
Accessories

Masking
Speakers &
Generators

Control
Accessories
& Electronics

Backboxes - Surface

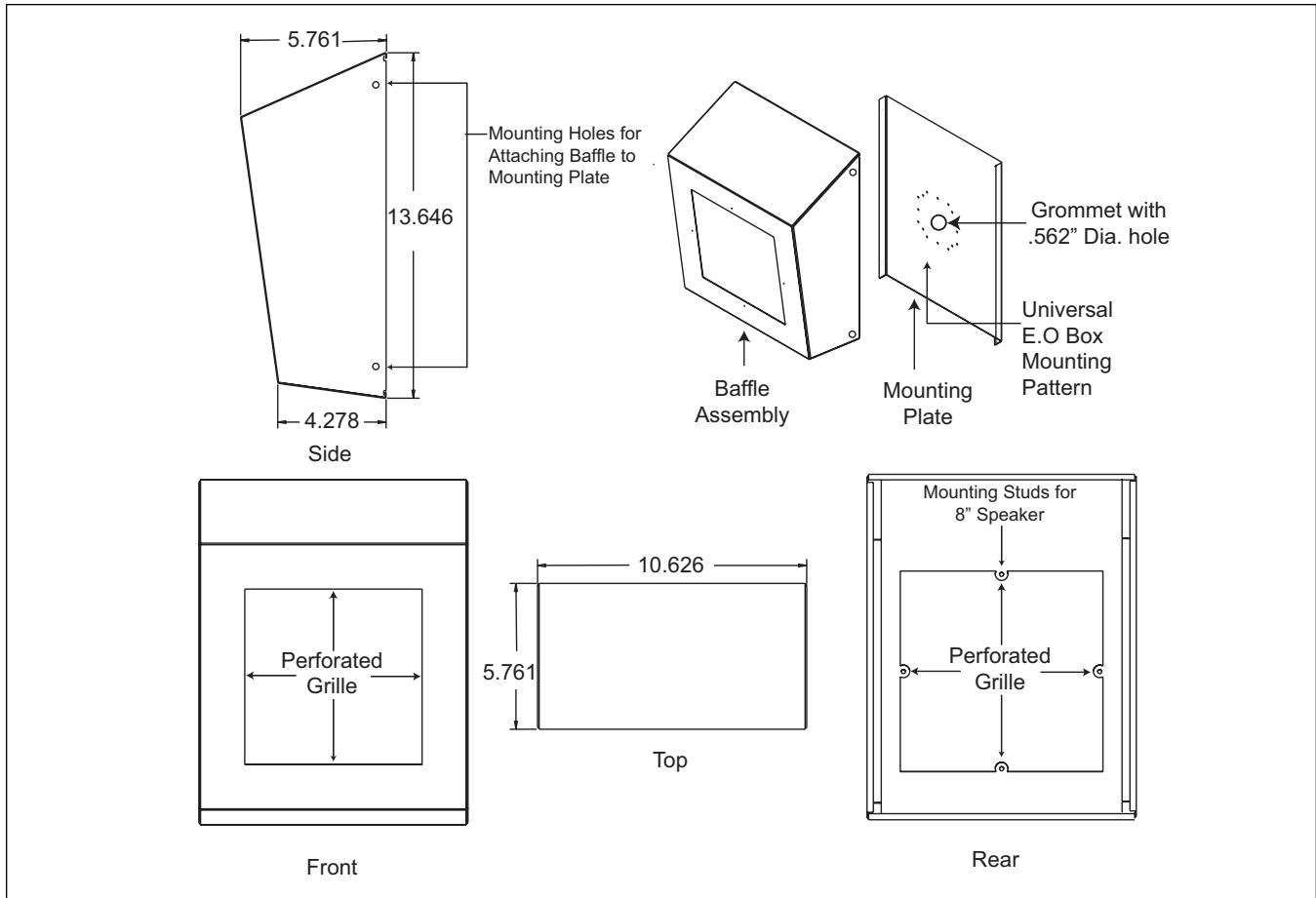

CEK-8M Specifications