

Description

Lowell CB86-6 and CB86-4 are attractive surface mounting backboxes for ceiling or wall installations of paging horn Model LUH-15T in schools, medical facilities, hotels, industrial and retail spaces where paging with high SPL output is required. Their clean, square design is precision formed from 20-gauge steel. Each Model features welded seams and 1.5" thick acoustic batting.

The rear of the backboxes are punched with a universal mounting pattern for installing to a 4" square, 4" octagon, 2-gang, or 1-gang E.O.Box. The rear also includes a .375" hole with grommet for wire access. The front features formed flanges with U-clips for secure screw mounting of vandal-resistant companion grille Model SQLK-8L (order grille separately). The CB86-6 backbox measures 9.563" SQ x 5.938"D and the CB86-4 measures 9.563" SQ x 4.00"D. The backbox is finished in Lowell's durable white powder epoxy paint.

Companion grille (order separately) Model SQLK-8L (9.5"SQ) is environment-resistant cast aluminum and includes a painted steel barrier screen and tamper-resistant screws. The grille is painted in durable white powder epoxy finish.

Companion drivers (order separately) Specify Lowell's narrow profile 15W Unihorn compression driver Model LUH-15T for paging applications where higher sound pressure levels are required.

A & E Specifications

The surface backbox for Unihorn compression driver Model LUH-15T shall be Lowell Model CB86-6 or CB86-4. The backbox shall be fabricated of 20-gauge steel and lined with 1.5" thick acoustic batting. The rear of the backbox shall include provisions for mounting to a 4" square, 4" octagon, 2-gang, or 1-gang E.O. Box. It shall also include a 3/8" diameter hole with grommet in the rear for wire access. The backbox shall be equipped with four (4) screw mounting holes and 8-32 U-clips at the flanged corners to accept companion grille Model SQLK-8L. The backbox shall measure _____ (9.563"SQ x 5.938"D, 9.625" x 4.00"D) and shall be finished in white powder epoxy paint.

Companion grille for backbox Model CB86-6 or CB86-4 shall be Lowell Model SQLK-8L. Grille shall be cast aluminum with a painted steel barrier screen. It shall measure 9.5" square, be finished in white powder epoxy and include mounting hardware.

Companion driver for backbox Model CB86-6 or CB86-4 shall be Lowell's narrow profile Unihorn compression driver Model LUH-15T with 15 W power-handling and 105 dB SPL (avg 1W1M) output.

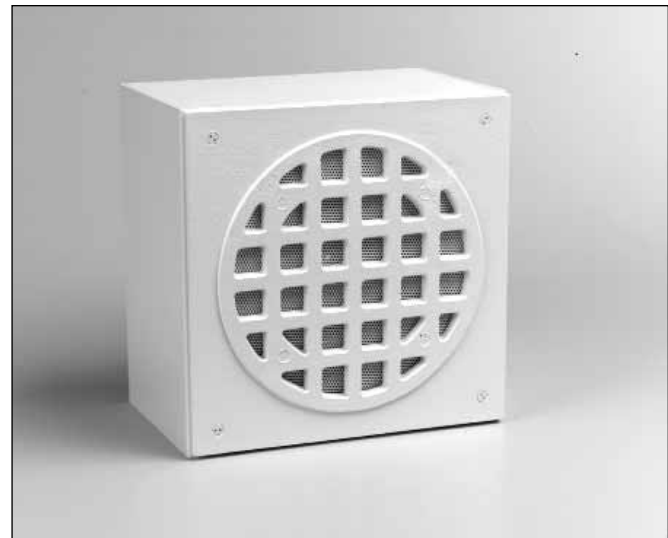

CB86-4
(Shown with SQLK-8L Grille - order separately)

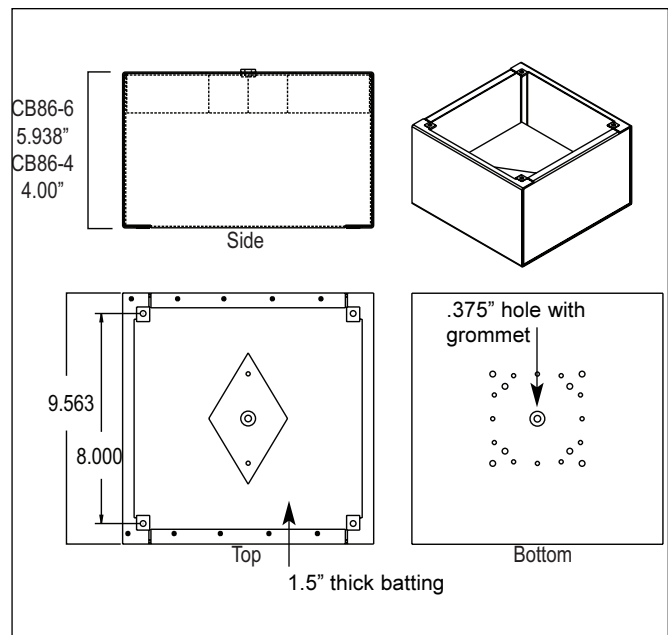

CB86 Series Specifications

| Backbox Specifications | | | | |
|------------------------|---|--------------------|---|-------------------------------------|
| Model | Description | Dimensions | Mounts Speaker Size* (order separately) | Mounts Grille (order separately) |
| CB86-6 | Surface backbox - 20ga. steel with 1.5" batting, white finish | 9.563"SQ x 5.938"D | LUH-15T Unihorn or flanged horn (by others) | SQLK-8L (cast aluminum) |
| CB86-4 | Surface backbox - 20ga. steel with 1.5" batting, white finish | 9.563"SQ x 4.00"D | LUH-15T Unihorn | SQLK-8L (cast aluminum) |

*Lowell's narrow profile 15W Unihorn compression driver Model LUH-15T requires less than 4"D. It may be used with either 4"D or 6"D backbox Series CB86.



CB86-6 and CB86-4

Surface Backbox for Unihorn Model LUH-15T

Companion Accessories for Backboxes CB86-6 and CB86-4 (Order Separately)

A
U
D
I
O

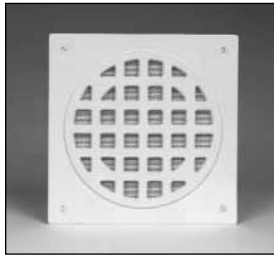

SQLK-8L Vandal-resistant
(9.5"SQ)

| Grille Model | Speaker Size | Grille Size | Visible Screws | Speaker Mount | Material | Color |
|--------------|-------------------|-------------|----------------|---------------|-------------|-------|
| SQLK-8L | 8" (or Unihorn**) | 9.5" Sq. | 4 | Studs | Cast alum.* | White |

* Vandal-resistant Model SQLK-8L features tamper-resistant hardware and a 22ga. perforated steel barrier screen to protect the speaker.

**Lowell's narrow profile 15W Unihorn compression driver Model LUH-15T requires less than 4"D. It may be used with 4"D or 6"D backbox series CB86.

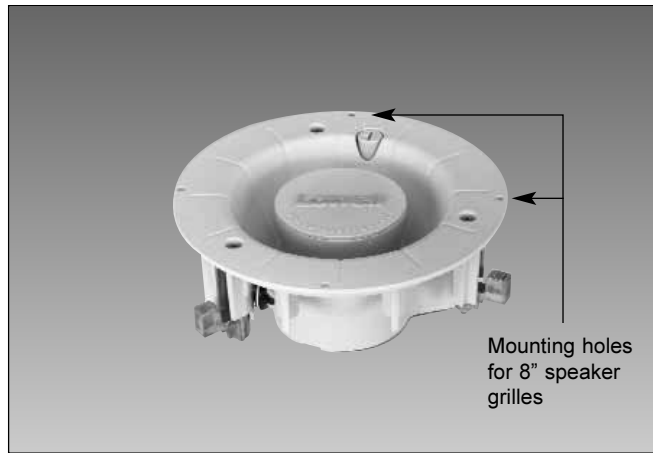

UNI HORN™ LUH-15T

12"/10"
Speakers &
Accessories

8"
Speakers &
Accessories

6"
Speakers &
Accessories

4"
Speakers &
Accessories

Horn
Speakers &
Accessories

Masking
Speakers &
Generators

Control
Accessories
& Electronics

PERFORMANCE

| | |
|-------------------------|--|
| Power Handling, Nominal | 15 watts RMS (nominal) measured per EIA Standard RS 426-B |
| Sensitivity | 110dB SPL (peak) 1W/1M, 105dB SPL (avg) 1W/1M |
| Frequency Response | 600Hz-12kHz (nominal), 740Hz-7.4kHz (±6dB) |
| Dispersion Angle | 80° @ 2000Hz octave (-6dB) |
| Impedance | 5000, 2500, 1300, 666, 333, 89, 45 ohms |
| Transformer Taps | 25V @ .48, .94, 1.8, 7.5, 15W; 70V @ .9, 1.8, 3.8, 7.5, 15W (adjustable front and rear. Rear features a rubber plug) |
| Capacitor | DC blocking series connected (10 uf NP) |

PHYSICAL

| | |
|---|---|
| Outside Size (horn housing) | 7.1" (180mm) Dia. housing with 8" (203mm) Dia. face x 3.72" (94mm)D |
| Outside Size (horn with trim ring/grille) | 7.1" (180mm) Dia. housing with 9.6" (244mm) Dia. trim ring/grille x 3.3" (84mm) D x .772" (19mm) Projection |
| Housing Material | Cast aluminum with gasketed rear cover |
| Trim Ring / Grille Material | Cast aluminum / perforated aluminum |
| Mounting Bolt Circle | 7.625 inch (194mm) with 4 holes spaced to mount an E.I.A. 8" speaker grille. |
| Cutout Diameter | 7.25 inch (184mm) |
| Net Weight | 6 lbs (2.72kg) |

Grilles & Backboxes