

# ADJ™ GOBO MOTION LED

American DJ®



## User Instructions

### Gobo Motion LED

### General Information

**Unpacking:** Thank you for purchasing the Gobo Motion LED by American DJ®. Every Gobo Motion LED has been thoroughly tested and has been shipped in perfect operating condition. Carefully check the shipping carton for damage that may have occurred during shipping. If the carton appears to be damaged, carefully inspect your fixture for any damage and be sure all equipment necessary to operate the unit has arrived intact. In the event damage has been found or parts are missing, please contact our toll free customer support number for further instructions. Please do not return this unit to your dealer without contacting customer support first.

**Introduction:** The Gobo Motion LED is a fast scanning, TRI LED, DMX intelligent fixture. The unit has 6 replaceable gobo patterns, or remove the gobos to have 6 solid beams of light. This unit has 3 DMX channel modes; 1 Channel mode, 3 Channel mode, and 18 Channel mode. The fixture has three operating modes; Sound Active mode, Show mode, or DMX Controlled. The unit can be set up as a stand alone unit or in a master-slave configuration. *For best results use fog or special effects smoke to enhance the beams projections.*

**Customer Support:** American DJ® provides a toll free customer support line, to provide help and to answer any question should you encounter problems during your set up or initial operation. You may also visit us on the web at [www.americandj.com](http://www.americandj.com) for any comments or suggestions. Service Hours are Monday through Friday 8:00 a.m. to 4:30 p.m. Pacific Standard Time.

Voice: (800) 322-6337

Fax: (323) 582-2941

E-mail: [support@americandj.com](mailto:support@americandj.com)

To purchase parts online visit <http://parts.americandj.com>

**Warning!** To prevent or reduce the risk of electrical shock or fire, do not expose this unit to rain or moisture.

**Warning!** *This may cause severe eye damage. Avoid looking directly into the light source at all times!*

## Gobo Motion LED

## General Instructions

To optimize the performance of this product, please read these operating instructions carefully to familiarize yourself with the basic operations of this unit. These instructions contain important safety information regarding the use and maintenance of this unit. Please keep this manual with the unit, for future reference.

## Gobo Motion LED

## Features

- DMX-512 Protocol Compatible
- 3 DMX Channel Modes; 1 Channel, 3 Channels, or 18 Channels
- RGB
- 3 Operating Modes - Sound Active, Show Mode, DMX Control
- Internal Microphone
- Digital Display for Address and Function Setting
- UC3 Controller (Not Included)
- Power Cord Daisy Chain

## Gobo Motion LED

## Warranty Registration

The Gobo Motion LED carries a 3 year (1095 days) limited warranty. Please fill out the enclosed warranty card to validate your purchase and warranty. You may also register your product online at [www.americandj.com](http://www.americandj.com). All returned service items whether under warranty or not, must be freight pre-paid and accompany a return authorization (R.A.) number. If the unit is under warranty you must provide a copy of your proof of purchase invoice. Please contact American DJ® customer support for a R.A. number.

## Gobo Motion LED

## Handling Precautions

**Caution!** There are no user serviceable parts inside this unit. Do not attempt any repairs yourself, doing so will void your manufacturer's warranty. In the unlikely event your unit may require service please contact American DJ®.

*American DJ® will not accept any liability for any resulting damages caused by the non-observance of this manual or any unauthorized modification to this unit.*

## Gobo Motion LED

## Safety Precautions

***For Your Own Personal Safety, Please Read and Understand This Manual Completely Before You Attempt To Install Or Operate This Unit!***

- To reduce the risk of electrical shock or fire, do not expose this unit rain or moisture
- Do not spill water or other liquids into or on to your unit.
- Be sure that the local power outlet match that of the required voltage for your unit.
- Do not attempt to operate this unit if the power cord has been frayed or broken.
- Do not attempt to remove or break off the ground prong from the electrical cord. This prong is used to reduce the risk of electrical shock and fire in case of an internal short.
- Disconnect from main power before making any type of connection.
- Do not remove the cover under any conditions. There are no user serviceable parts inside.
- Never operate this unit when it's cover is removed.
- Always be sure to mount this unit in an area that will allow proper ventilation. Allow about 6" (15cm) between this device and a wall.
- Do not attempt to operate this unit, if it becomes damaged.
- This unit is intended for indoor use only, use of this product outdoors voids all warranties.
- Always mount this unit in safe and stable matter.
- Power-supply cords should be routed so that they are not likely to be walked on or pinched by items placed upon or against them, paying particular attention to cords at plugs, convenience receptacles, and the point where they exit from the appliance.
- Cleaning -The fixture should be cleaned only as recommended by the manufacturer. See page 14 for cleaning details.
- Heat -This fixture should be situated away from heat sources such as radiators, heat registers, stoves, or other appliances (including amplifiers) that produce heat.
- The fixture should be serviced by qualified service personnel when:
  - A. Objects have fallen, or liquid has been spilled into the appliance.
  - B. The appliance has been exposed to rain or water.
  - C. The appliance does not appear to operate normally or exhibits a marked change in performance.

**Power Supply:** The American DJ® Gobo Motion LED contains an automatic voltage switch, which will auto sense the voltage when it is plugged into the power source. With this switch there is no need to worry about the correct power voltage, this unit can be plugged in anywhere.

**DMX-512:** DMX is short for Digital Multiplex. This is a universal protocol used by most lighting and controller manufacturers as a form of communication between intelligent fixtures and controllers. A DMX controller sends DMX data instructions from the controller to the fixture. DMX data is sent as serial data that travels from fixture to fixture via the DATA “IN” and DATA “OUT” XLR terminals located on all DMX fixtures (most controllers only have a DATA “OUT” terminal).

**DMX Linking:** DMX is a language allowing all makes and models of different manufacturers to be linked together and operate from a single controller, as long as all fixtures and the controller are DMX compliant. To ensure proper DMX data transmission, when using several DMX fixtures try to use the shortest cable path possible. The order in which fixtures are connected in a DMX line does not influence the DMX addressing. For example; a fixture assigned a DMX address of 1 may be placed anywhere in a DMX line, at the beginning, at the end, or anywhere in the middle. Therefore, the first fixture controlled by the controller could be the last fixture in the chain. When a fixture is assigned a DMX address of 1, the DMX controller knows to send DATA assigned to address 1 to that unit, no matter where it is located in the DMX chain.

**Data Cable (DMX Cable) Requirements (For DMX and Master/Slave Operation):**

The Gobo Motion LED can be controlled via DMX-512 protocol. The Gobo Motion LED has 3 DMX Channel modes. You can choose from 1 Channel mode, 3 Channel mode, or 18 Channel mode. The DMX address is set electronically using the controls on the rear panel of the unit. Your unit and your DMX controller require a standard 3-pin XLR connector for data input and data output (Figure 1). If you are making your own cables, be sure to use standard two conductor shielded cable (This cable may be purchased at almost all professional sound and lighting stores). Your



Figure 1

cables should be made with a male and female XLR connector on either end of the cable. Also remember that DMX cable must be daisy chained and cannot be split.

**Notice:** Be sure to follow figures two and three when making your own cables. Do not use the ground lug on the XLR connector. Do not connect the cable’s shield conductor to the ground lug or allow the shield conductor to come in contact with the XLR’s outer casing. Grounding the shield could cause a short circuit and erratic behavior.

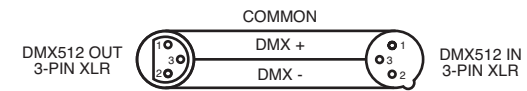

Figure 2

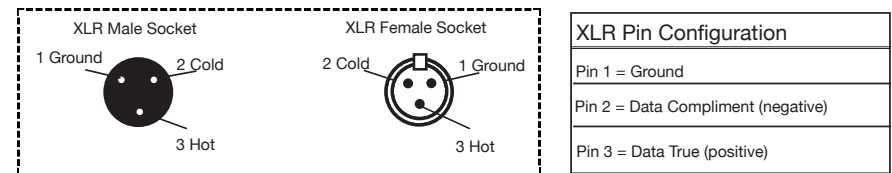

Figure 3

**Special Note: Line Termination.** When longer runs of cable are used, you may need to use a terminator on the last unit to avoid erratic behavior. A terminator is a 90-120 ohm 1/4 watt resistor which is connected between pins 2 and 3 of a male XLR connector (DATA + and DATA -). This unit is inserted in the female XLR connector of the last unit in your daisy chain to terminate the line. Using a cable terminator (ADJ part number Z-DMX/T) will decrease the possibilities of erratic behavior.



Termination reduces signal errors and avoids signal transmission problems and interference. It is always advisable to connect a DMX terminal, (Resistance 120 Ohm 1/4 W) between PIN 2 (DMX-) and PIN 3 (DMX +) of the last fixture.

Figure 4

**5-Pin XLR DMX Connectors.** Some manufactures use 5-pin XLR connectors for DATA transmission in place of 3-pin. 5-pin XLR fixtures may be implemented in a 3-pin XLR DMX line. When inserting standard 5-pin XLR connectors in to a 3-pin line a cable adaptor must be used, these adaptors are readily available at most electric stores. The chart below details a proper cable conversion.

3-Pin XLR to 5-Pin XLR Conversion		
Conductor	3-Pin XLR Female (Out)	5-Pin XLR Male (In)
Ground/Shield	Pin 1	Pin 1
Data Compliment (- signal)	Pin 2	Pin 2
Data True (+ signal)	Pin 3	Pin 3
Not Used		Pin 4 - Do Not Use
Not Used		Pin 5 - Do Not Use

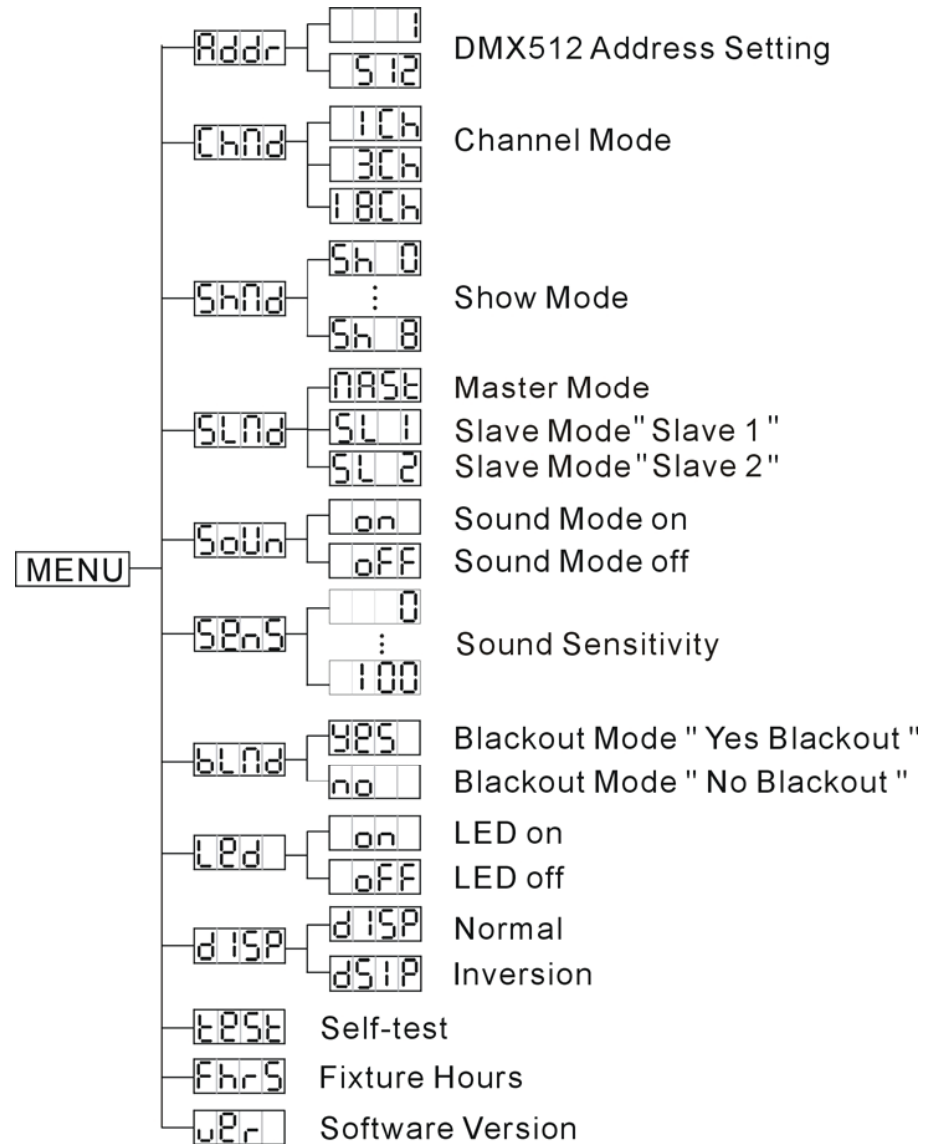

**System Menu:** When making adjustments press **ENTER** to confirm your setup and then press and hold the **MENU** button for at least 3 seconds. To exit without making any adjustments press the **MENU** button.

### **ADDR** - DMX Address Setting.

1. Press the either the MENU, UP, or DOWN buttons until "ADDR" is displayed, press ENTER.
2. The current address will now be displayed and flashing. Press the UP or DOWN buttons to find your desired address. When you have found your desired address press ENTER.

### **CHND** - This will let you switch between 1 Channel mode, 3 Channel mode, and 18 Channel mode.

1. Press the MENU button until "CHND" is displayed, press ENTER. Either "1CH", "3CH" or "18CH" will be displayed
2. Press the UP or DOWN buttons to choose your desired DMX mode and press ENTER to confirm and exit.

### **SHND: Sh 0 - Sh 8** - Show modes 0-8 (Factory programs). Show mode can run with or without sound active mode.

1. Press the MENU button until "SHND" is displayed, press ENTER.
2. "Sh X" will now be displayed, "X" representing a number between 0-8. Programs 1-8 are factory programs, while "Sh 0" is random mode. Press the UP or DOWN buttons to find your desired show.
3. When you have found your desired show press ENTER, then press and hold the MENU button for at least 3 seconds to activate.

### **SLND** - This will let you set unit as a master or slave in a master/slave configuration.

1. Press the MENU button until "SLND" is displayed, press ENTER. "MSTR", "SL 1" or "SL 2" will be displayed.
2. Press the UP or DOWN buttons until your desired setting is displayed, press ENTER to confirm and exit.

### **SOUN** - Sound Active mode.

1. Press the MENU button until "SOUN" is displayed, press ENTER.
2. The display will show either "ON" or "OFF". Press the UP or DOWN buttons to select "ON" to activate sound active mode, or "OFF" to deactivate sound active mode.
3. Press ENTER, and then press and hold the MENU button for at least 3 seconds to activate.

### **SENS** - Sound sensitivity control.

1. Press the MENU button until "SENS" is displayed, press ENTER.
2. The display will show a number between 0-100. Press the UP or DOWN buttons to adjust the sound sensitivity. 0 being the least sensitive and 100 the most sensitive.
3. Press the ENTER button to confirm.

### **BLND** - Blackout or Stand by mode.

1. Press the MENU button until "BLND" is displayed, press ENTER. Either Yes or No will be displayed.
2. To activate Blackout tap the UP or DOWN buttons until Yes is displayed, press ENTER to confirm and exit. The fixture will now be in Blackout mode. To deactivate Blackout mode, select No

and press Enter.

**LED** - With this function you can switch the LED on or off via the control board.

1. Press the MENU button until “LED” is displayed, press ENTER.
2. The display will show either “ON” or “OFF”. Press the UP or DOWN buttons to select “ON” to switch on the LED, or “OFF” to switch off the LED.
3. Press ENTER to confirm and exit.

**DISP** - This function will reverse the display 180°.

1. Press the MENU button until “DISP” is displayed, press ENTER.
2. Press the UP button to select “DISP” to activate this function, or “DISP” to deactivate this function.
3. Press ENTER to confirm.

**TEST** - This function will run a self test program.

1. Press the MENU button until “TEST” is displayed, press ENTER.
2. The fixture will now run a self test.

**FHRS** - With this function you can display the running time of the unit.

1. Press the MENU button until “FHRS” is displayed, press ENTER.
2. The display shows the running time of the unit. Press MENU to exit.

**VER** - Use this function to display the Software version of the unit.

1. Press the MENU button until “VER” is displayed, press ENTER.
2. The display will show the software version.

*With this feature you can connect the fixtures to one another using the IEC input and output sockets. The quantity that can be connected is 9 fixtures maximum. After 9 fixtures you will need to use a new power outlet. They must be the same fixtures. DO NOT mix fixtures.*

The Gobo Motion LED comes with 6 replaceable gobos. These gobos can be interchanged at any time and allows you to customize your system.

To replace gobo;

1. Unscrew the thumb screw located at the top that hold the gobo housing.
2. Remove the gobo housing.
3. Once the gobo housing has been removed, remove the retaining ring that holds the gobo in place. This can easily be done using needle nose pliers.
4. Remove and replace the gobo with your desired replacement. Reinsert the retainer ring, and make sure the ring rests firmly against the gobo.
5. Slide the gobo assembly back into place, and secure the housing using thumb screw.

**Operating Modes:** The Gobo Motion LED can operate in three different modes. In each mode you can run the fixture as a stand alone fixture or in a master/slave configuration. This next section will detail the differences in the operating modes.

- **Sound Active mode -**

The fixture will react to sound, chasing through the built-in programs.

- **Show mode -**

Choose 1 of 8 show modes to run.

- **DMX control mode -**

This function will allow you to control each individual fixtures traits with a standard DMX-512 controller such as the Elation® Show Designer.™

**Universal DMX Control:** This function allows you to use a Elation® universal DMX-512 controller to control the chases and patterns, dimmer and strobe. A DMX controller allows you to create unique programs tailored to your individual needs.

1. The Gobo Motion LED has three DMX Channel modes; 1 channel mode, 3 Channel mode, and 18 Channel mode. To set the channel mode see page 9. See pages 15-17 for detailed description of the DMX traits.
2. To control your fixture in DMX mode, follow the set-up procedures on pages 5-7 as well as the set-up specifications that are included with your DMX controller.
3. Use the controller's faders to control the various DMX fixture traits.
4. This will allow you to create your own programs.
5. Follow the instruction on page 9 to set the DMX address.
6. For longer cable runs (more than a 100 feet) use a terminator on the last fixture.
7. For help operating in DMX mode consult the manual included with your DMX controller.

**Sound Active Mode:** This mode allows either single unit or several units linked together, to run to the beat of the music.

1. Tap the MENU button until "SOUND" is displayed, and press ENTER.
2. Tap the UP or DOWN buttons to choose either OFF or ON, and press ENTER, then press and hold MENU for 3 seconds to con-

firm. To adjust the sound sensitivity see page 10.

3. The optional *UC3 Controller* (not included) may be used to control different functions including blackout. See page 15 for UC3 controls.

**Show Mode:** In this mode you can choose 1 of 8 show modes to run. This operating mode can be used in stand alone unit or in a master-slave configuration.

1. Tap the MENU button until "SHOW" is displayed, and press ENTER.
2. Tap the UP or DOWN buttons until you find your desired show, and press ENTER then press and hold MENU for 3 seconds to confirm. See page 9 for more info.
3. The optional *UC3 Controller* (not included) may be used to control different functions including blackout. See page 15 for UC3 controls.

**Master-Slave Operation** This function will allow you to link up to 16 units together and operate without a controller. The units will be sound activated. In Master-Slave operation one unit will act as the controlling unit and the others will react to the controlling units programs. Any unit can act as a Master or as a Slave.

1. Using approved DMX data cables, daisy chain your units together via the XLR connector on the rear of the units. Remember the Male XLR connector is the input and the Female XLR connector is the output. The first unit in the chain (master) will use the female XLR connector only - The last unit in the chain will use the male XLR connector only. For longer cable runs we suggest a terminator at the last fixture.
2. For the Master unit press the MENU button until "SLND" is displayed, and Press ENTER. Set the unit to "FIRST" and press ENTER.
3. Next set the Master to your desired operating mode.
4. For the slave units press the MENU button until "SLND" is displayed, and Press ENTER. Set the slave units to either "SL 1" or "SL 2".
5. The slave units will now follow the Master unit.
6. The optional *UC3 Controller* (not included) may be used to control different functions including blackout. See page 15 for UC3 controls.

## Gobo Motion LED

## UC3 Control

Blackout	Blackout the unit		
Function	<b>Strobe</b> 1. Synchronous strobe in white 2. Sound strobe in white 3. Sound strobe in color	<b>Select color</b> 1.Red 2.Green 3.Blue 4.Red+Green 5.Red+Blue 6.Green+Blue 7.Red+Green+Blue 8.Color change by sound	<b>Select show</b> 1-8
Mode	Sound (LED OFF)	Manual Color(LED ON)	Show(LED slow blinking)

## Gobo Motion LED

## 1 DMX Channel Mode

Channel	Value	Function
1	0 - 7	SHOWS
	8 - 37	BLACKOUT
	38 - 67	SHOW 1
	68 - 97	SHOW 2
	98 - 127	SHOW 3
	128 - 157	SHOW 4
	158 - 187	SHOW 5
	188 - 217	SHOW 6
	218 - 247	SHOW 7
	248 - 255	SHOW 8
		SOUND ACTIVE

## Gobo Motion LED

## 3 DMX Channel Mode

Channel	Value	Function
1	0 - 7	CHASES
	8 - 23	BLACKOUT
	24 - 39	CHASE 1
	40 - 55	CHASE 2
	56 - 71	CHASE 3
	72 - 87	CHASE 4
	88 - 103	CHASE 5
	104 - 119	CHASE 6
	120 - 135	CHASE 7
	136 - 151	CHASE 8
	152 - 167	CHASE 9
	168 - 183	CHASE 10
	184 - 199	CHASE 11
	200 - 215	CHASE 12
	216 - 231	CHASE 13
232 - 247	CHASE 14	
248 - 255	CHASE 15	
		SOUND ACTIVE
2	0 - 255	MASTER DIMMER 0% - 100%
3	0 - 7	STROBING
	8 - 247	BLACKOUT
		STROBING SLOW - FAST
	248 - 255	SOUND ACTIVE STROBING



Gobo Motion LED		18 DMX Channel Mode
Channel	Value	Function
1	0 - 255	RED (LENS 1) 0% - 100%
2	0 - 255	GREEN (LENS 1) 0% - 100%
3	0 - 255	BLUE (LENS 1) 0% - 100%
4	0 - 255	RED (LENS 2) 0% - 100%
5	0 - 255	GREEN (LENS 2) 0% - 100%
6	0 - 255	BLUE (LENS 2) 0% - 100%
7	0 - 255	RED (LENS 3) 0% - 100%
8	0 - 255	GREEN (LENS 3) 0% - 100%
9	0 - 255	BLUE (LENS 3) 0% - 100%
10	0 - 255	RED (LENS 4) 0% - 100%
11	0 - 255	GREEN (LENS 4) 0% - 100%
12	0 - 255	BLUE (LENS 4) 0% - 100%
13	0 - 255	RED (LENS 5) 0% - 100%
14	0 - 255	GREEN (LENS 5) 0% - 100%
15	0 - 255	BLUE (LENS 5) 0% - 100%
16	0 - 255	RED (LENS 6) 0% - 100%
17	0 - 255	GREEN (LENS 6) 0% - 100%
18	0 - 255	BLUE (LENS 6) 0% - 100%

## Gobo Motion LED Fuse Replacement

Disconnect the unit from its power source. Remove the power cord from the unit. Once the cord has been removed, you will find that the fuse holder is located inside the power socket. Insert a flat-head screw driver into the power socket and gently pry out the fuse holder. Remove the bad fuse and replace with a new one. The fuse holder also has a holder for a spare fuse.

## Gobo Motion LED Cleaning

**Fixture Cleaning:** Due to fog residue, smoke, and dust cleaning the internal and external optical lenses and mirror should be carried out periodically to optimize light output. Cleaning frequency depends on the environment in which the fixture operates (i.e. smoke, fog residue, dust, dew). In heavy club use we recommend cleaning on a monthly basis. Periodic cleaning will ensure longevity, and crisp output.

1. Use normal glass cleaner and a soft cloth to wipe down the outside casing.
2. Use a brush to wipe down the cooling vents and fan grill.
3. Clean the external optics and mirror with glass cleaner and a soft cloth every 20 days.
4. Clean the internal optics with glass cleaner and a soft cloth every 30-60 days.
5. Always be sure to dry all parts completely before plugging the unit back in.

## Gobo Motion LED Trouble Shooting

**Trouble Shooting:** Listed below are a few common problems that you may encounter, with solutions.

### **No light output from the unit;**

1. Be sure the external fuse has not blown. The fuse is located on the rear panel of the unit.
2. Be sure the fuse holder is completely and properly seated.

### **Unit does not respond to sound;**

1. Low frequencies (bass) should cause the unit to react to sound. Tapping on the microphone, quiet or high pitched sounds may not activate the unit.

## Gobo Motion LED

## Warranty

### MANUFACTURER'S LIMITED WARRANTY

A. American DJ, Inc. hereby warrants, to the original purchaser, American DJ and American Audio products to be free of manufacturing defects in material and workmanship for a prescribed period from the date of purchase (see specific warranty period on reverse). This warranty shall be valid only if the product is purchased within the United States of America, including possessions and territories. It is the owner's responsibility to establish the date and place of purchase by acceptable evidence, at the time service is sought.

B. For warranty service you must obtain a Return Authorization number (RA#) before sending back the product. Contact American DJ, Inc. Service Department at 800-322-6337. Send the product only to the American DJ, Inc. factory. All shipping charges must be pre-paid. If the requested repairs or service (including parts replacement) are within the terms of this warranty, American DJ, Inc. will pay return shipping charges only to a designated point within the United States. If the entire instrument is sent, it must be shipped in its original package. No accessories should be shipped with the product. If any accessories are shipped with the product, American DJ, Inc. shall have no liability whatsoever for loss of or damage to any such accessories, nor for the safe return thereof.

C. This warranty is void if the serial number has been altered or removed; if the product is modified in any manner which American DJ, Inc. concludes, after inspection, affects the reliability of the product; if the product has been repaired or serviced by anyone other than the American DJ, Inc. factory unless prior written authorization was issued to purchaser by American DJ, Inc.; if the product is damaged because not properly maintained as set forth in the instruction manual.

D. This is not a service contract, and this warranty does not include maintenance, cleaning or periodic check-up. During the period specified above, American DJ, Inc. will replace defective parts at its expense with new or refurbished parts, and will absorb all expenses for warranty service and repair labor by reason of defects in material or workmanship. The sole responsibility of American DJ, Inc. under this warranty shall be limited to the repair of the product, or replacement thereof, including parts, at the sole discretion of American DJ. All products covered by this warranty were manufactured after January 1, 1990, and bear identifying marks to that effect.

E. American DJ, Inc. reserves the right to make changes in design and/or improvements upon its products without any obligation to include these changes in any products theretofore manufactured. No warranty, whether expressed or implied, is given or made with respect to any accessory supplied with products described above. Except to the extent prohibited by applicable law, all implied warranties made by American DJ, Inc. in connection with this product, including warranties of merchantability or fitness, are limited in duration to the warranty period set forth above. And no warranties, whether expressed or implied, including warranties of merchantability or fitness, shall apply to this product after said period has expired. The consumer's and/or Dealer's sole remedy shall be such repair or replacement as is expressly provided above; and under no circumstances shall American DJ, Inc. be liable for any loss or damage, direct or consequential, arising out of the use of, or inability to use, this product.

This warranty is the only written warranty applicable to American DJ and American Audio Products and supersedes all prior warranties and written descriptions of warranty terms and conditions heretofore published.

### MANUFACTURER'S LIMITED WARRANTY PERIODS:

- All American Audio Products = 1-year (365 day) Limited Warranty (except V-Plus Series Amplifiers)
- All American Audio V-Plus Series Amplifiers = 3-year (1095 day) Limited Warranty
- American DJ Lighting and American DJ Branded Products = 1-year (365 day) Limited Warranty (Such as: Special Effect Lighting, Intelligent Lighting, UV lighting, Strobos, Fog Machines, Bubble Machines, Mirror Balls, Par Cans, Trussing, Lighting Stands etc. excluding Laser Products, lamps, and Star Tec Series)
- American DJ Laser Products and Star Tec Products = 90-Day Limited Warranty
- American DJ L.E.D. Products = 3-year (1095 day) Limited Warranty (excluding motors which have a 1-year (365 day Limited Warranty))

American DJ® - [www.americandj.com](http://www.americandj.com) - Gobo Motion LED Instruction Manual Page 19

## Gobo Motion LED

## Specifications

<b>Model:</b>	<b>Gobo Motion LED</b>
<b>Voltage:</b>	100V ~ 240V/50~60Hz
<b>LEDs:</b>	6 x 3W 3-in-1 RGB LEDs
<b>Power Consumption:</b>	34W
<b>Fuse:</b>	7A
<b>Power Cord Daisy Chain:</b>	9 Fixtures Max.
<b>Dimensions:</b>	17"(L) x 8.5"(W) x 5.75"(H) 428mm x 211mm x 143mm
<b>Weight:</b>	8 Lbs. / 3.6 kgs.
<b>Colors:</b>	RGB
<b>Gobos:</b>	20.5mm 12mm (Viewable)
<b>Beam Angle:</b>	8.5 Degrees (Single Beam) 75 Degrees (Multiple Beams)
<b>Duty Cycle:</b>	None
<b>DMX:</b>	1, 3, or 18 DMX Channels
<b>Sound Active:</b>	Yes
<b>Working Position:</b>	Any Safe, Secure Position
<b>Warranty:</b>	3 Year (1095 days)

**Auto Sensing Voltage:** *This fixture contains a automatic voltage switch, which will auto sense the voltage when it is plugged into the power source.*

**Please Note:** *Specifications and improvements in the design of this unit and this manual are subject to change without any prior written notice.*

©American DJ Supply

American DJ World Headquarters:  
6122 S. Eastern Ave. Los Angeles, CA 90040 USA  
Tel: 323-582-2650 / Fax: 323-725-6100

Web: [www.americandj.com](http://www.americandj.com) / E-mail: [info@americandj.com](mailto:info@americandj.com)

American DJ Europe  
Junostraat 2  
6468 EW Kerkrade  
Netherlands

### Follow Us On:



[facebook.com/americandj](https://facebook.com/americandj)  
[twitter.com/americandj](https://twitter.com/americandj)  
[youtube.com/adjlighting](https://youtube.com/adjlighting)

[service@adjgroup.eu](mailto:service@adjgroup.eu) / [www.americandj.eu](http://www.americandj.eu)  
Tel: +31 45 546 85 00 / Fax: +31 45 546 85 99