



WIFLEX DMX SYSTEM

Wireless DMX Transmitter/Receiver System

Introduction:

Congratulations and thank you for purchasing the American DJ WiFlex System. The WiFlex System is a transmitter and receiver package that is compatible with all standard DMX controllers and fixtures in the market. It is designed to transmit DMX signals wirelessly, up to 500 feet, between your DMX console and fixtures. One WiFlex transmitter can send a constant/reliable signal to several WiFlex receivers. The WiFlex DMX System features a special frequency-hopping algorithm that is more advanced than the standard FHSS technology. The algorithm used in WiFlex DMX avoids "Blackout" period, which is caused by interference from other W-LAN or any other wireless products using the 2.45 GHz band, and only uses channels that are not used. WiFlex DMX is the ideal solution for DJ's, nightclubs, bars or for any event where you don't want data cables to be seen and when it is not easy to run data cables to your fixture(s) location.

Customer Support: American DJ® provides a toll free customer support line, to provide set up help and to answer any question should you encounter problems during your set up or initial operation. You may also visit us on the web at www.americandj.com for any comments or suggestions. *For service related issue please contact American DJ®.* Service Hours are Monday through Friday 8:00 a.m. to 4:30 p.m. Pacific Standard Time.

Voice: (800) 322-6337
 Fax: (323) 582-2941
 E-mail: support@americandj.com

To purchase parts online visit <http://parts.americandj.com>

Caution! There are no user serviceable parts inside this unit. Do not attempt any repairs yourself, doing so will void your manufacturer's warranty. In the unlikely event your unit may require service please contact American DJ customer support.

The WiFlex System carries a 1 Year (365 days) limited warranty. Please fill out the enclosed warranty card to validate your purchase. All returned service items whether under warranty or not, must be freight pre-paid and accompany a return authorization (R.A.) number. If the unit is under warranty you must provide a copy of your proof of purchase invoice. Please contact American DJ® customer support for a R.A. number. For additional warranty info please visit our website.

SET UP AND SYNCH: When using the WiFlex System please refer to your fixtures user manual for its individual DMX channel modes, functions, & traits. Please see other side for the WiFlex System connections and functions.

1. Connect a DMX controller to the DMX Input on your WiFlex transmitter.
2. Connect your desired fixture to the DMX Output on the WiFlex receiver.
3. Press the register button on both boxes to synch the signals. You should now be able to control the fixture wirelessly.

Specifications:

Voltage.....	100~240V, 50~60Hz
Power Consumption.....	2W Max.
RF Frequency Band.....	2.400~2.483MHz
RF Channels.....	1-16
RF Channel Data Rate.....	250Kbps
RF Transmitter Power.....	≥18dBm
RF Receiver Sensitivity.....	≥-90dBm
Dimensions.....	4.37" (L) x 4.33" (W) x 1.57"
(H) Weight.....	0.79lbs/0.36Kg

WiFlex System Set Up

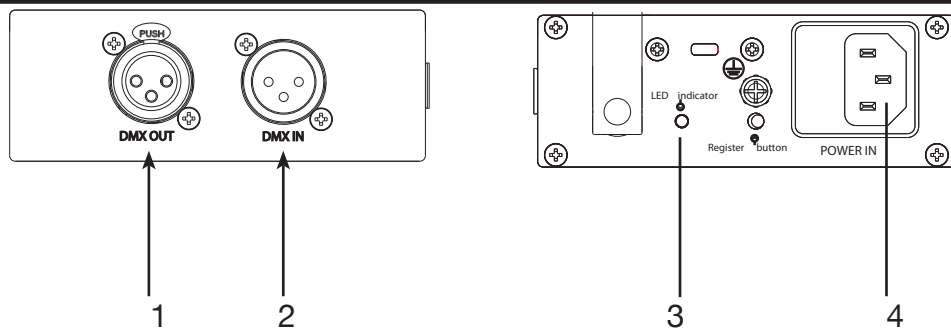
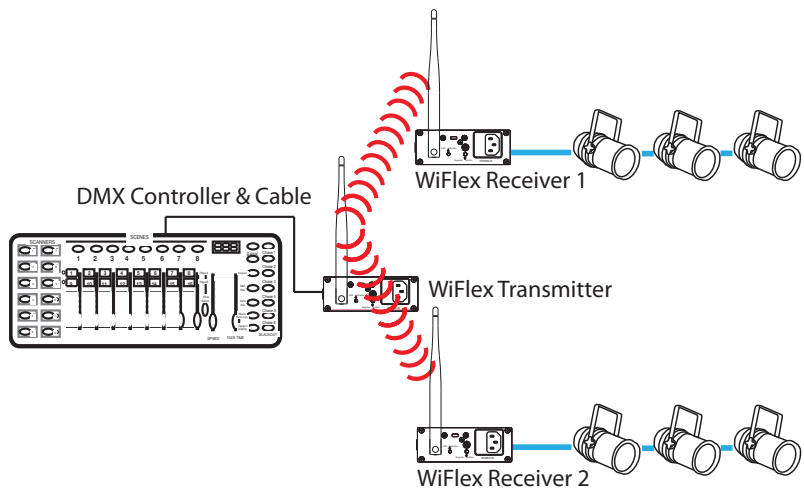

CONNECTIONS AND FUNCTIONS -

WiFlex System:

1. **DMX Out** - Use the DMX Out jack to connect DMX abled lights.
2. **DMX In** - Use the DMX In jack to connect to a DMX controller.
3. **Register Button** - Press this button located on the transmitter and receiver to sync the two boxes.
4. **Power In** - This is the power cord connection.

LED INDICATOR STATUS -

WiFlex Transmitter:

1. **LED Stays On** - This means that there is no DMX signal.
2. **LED Slow Flash** - This means that it is receiving a DMX signal.
3. **LED Fast Flash** - This means that the transmitter is registering.

WiFlex Receiver:

1. **LED is Off** - This means that the receiver is not registered to any transmitter.
2. **LED Stays On** - This means that the receiver cannot find the transmitter.
3. **LED Slow Flash** - This means that the receiver is linked to a transmitter.
4. **LED Fast Flash** - This means that the receiver is registering.

American DJ®
American DJ World Headquarters:
6122 S. Eastern Ave. Los Angeles, CA 90040 USA
Tel: 323-582-2650 / Fax: 323-725-6100
Web: www.americandj.com/
E-mail: info@americandj.com

American DJ Europe
Junostraat 2
6468 EW Kerkrade
Netherlands
Tel: +31 45 546 85 00 / Fax: +31 45 546 85 99
service@adjgroup.eu / www.americandj.eu