

Beam angle 16°
Field angle 36° of Red LEDs (LENS 25°)
Intensity LUX 2686 870 434

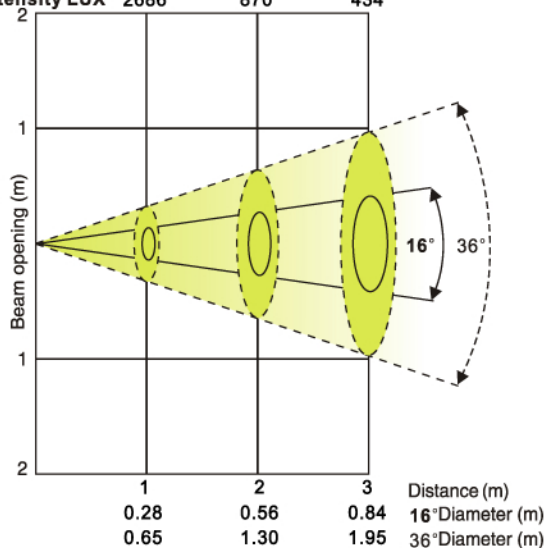

Beam angle 16°
Field angle 36° of Green LEDs (LENS 25°)
Intensity LUX 5514 1996 988

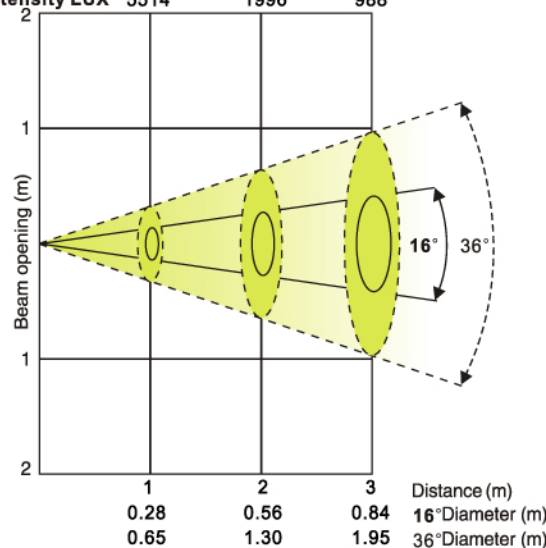

Beam angle 16°
Field angle 36° of Blue LEDs (LENS 25°)
Intensity LUX 1180 430 222

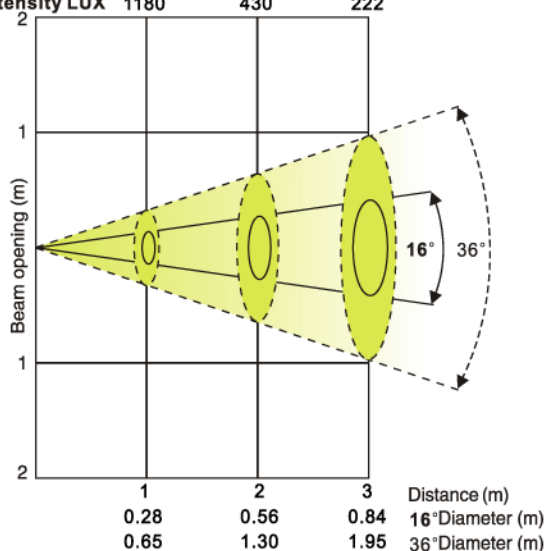

Beam angle 16°
Field angle 36° of White LEDs (LENS 25°)
Intensity LUX 4782 1732 855

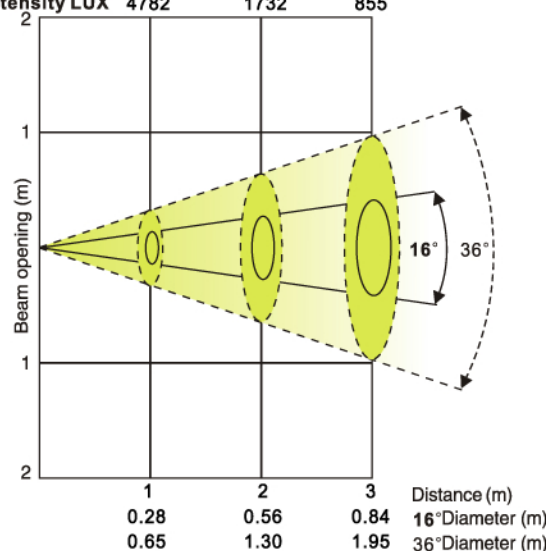

Beam angle 16°
Field angle 36° of Amber LEDs (LENS 25°)
Intensity LUX 3947 1471 733

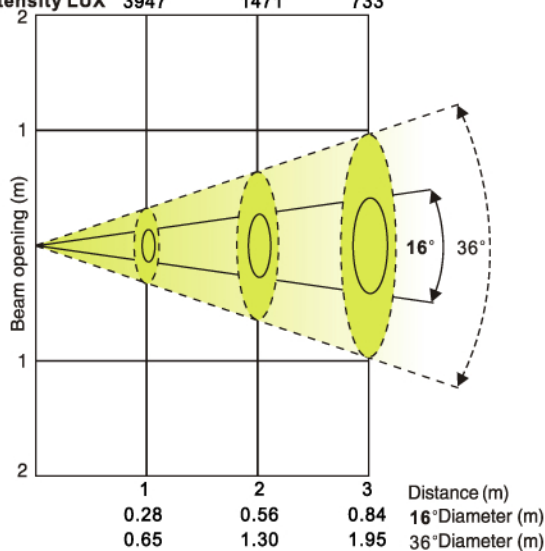

Beam angle 16°
Field angle 36° of Full LEDs (LENS 25°)
Intensity LUX 15760 5890 2913

