

Prompter Kit for Apple iPad

TP-200



Instruction Manual

www.datavideo-tek.com

Contents

Warnings and Precautions	3
Warranty.....	4
Disposal.....	4
Packing List	5
Product Overview	6
Features.....	6
Example Configurations	7
Normal Tripod Set Up.....	7
Below Camera Lens Set Up	7
Assembly	8
Normal Tripod Set Up.....	8
Camera Exposure.....	9
Using Riser Blocks	9
Below Lens Assembly	10
Software Download from the App Store™	11
DV Prompter Application Set Up.....	11
Display Settings.....	11
Prompting Settings	12
Start Settings	12
Remote Settings	12
Build Version	12
Apple iPad™ Settings.....	12
How to quickly add text into a DV Prompter document.....	13
Importing a Text file via iTunes™	13
Using the wired Remote Control.....	14
Play Button	14
Stop Button.....	14
Increase and Decrease Speed Buttons.....	14
Break Markers	14
Optional wireless remote available.....	14
Cleaning the 60/40 Glass sheet.....	15
Specifications	16
Service and Support	17

Disclaimer of Product and Services

The information offered in this instruction manual is intended as a guide only. At all times, Datavideo Technologies will try to give correct, complete and suitable information. However, Datavideo Technologies cannot exclude that some information in this manual, from time to time, may not be correct or may be incomplete. This manual may contain typing errors, omissions or incorrect information. Datavideo Technologies always recommend that you double check the information in this document for accuracy before making any purchase decision or using the product. Datavideo Technologies is not responsible for any omissions or errors, or for any subsequent loss or damage caused by using the information contained within this manual. Further advice on the content of this manual or on the product can be obtained by contacting your local Datavideo Office or dealer.



Warnings and Precautions

1. Read all of these warnings and save them for later reference.
2. Follow all warnings and instructions marked on this unit.
3. Unplug this unit from the wall outlet before cleaning. Do not use liquid or aerosol cleaners. Use a slightly damp cloth for cleaning.
4. Do not use this unit in or near water.
5. Do not place this unit on an unstable surface, cart, stand, or table. The unit may fall, causing serious damage.
6. Any slots and openings on the case top, back, and bottom are provided for ventilation. To ensure safe and reliable operation of this unit, and to protect it from overheating, do not block or cover these openings. Do not place this unit on a bed, sofa, rug, or similar surface, as the ventilation openings may become blocked. This unit should never be placed near or over a heat source or radiator. This unit should not be placed in a built-in installation unless proper ventilation is provided.
7. This product should only be operated from the type of power source indicated on the marking label of the AC adapter. If you are not sure of the type of power available, consult your Datavideo dealer or your local power company.
8. Do not allow anything to rest on the power cord. Do not locate this unit where the power cord will be walked on, rolled over, damaged or otherwise stressed.
9. If an extension cord must be used with this unit, make sure that the total of the ampere ratings on the products plugged into the extension cord do not exceed the extension cord's rating.
10. Make sure that the total amperes of all the units that are plugged into a single wall outlet do not exceed 15 amperes.
11. Never push objects of any kind into this unit through the case ventilation slots, as they may touch dangerous voltage points or short out parts that could result in risk of fire or electric shock. Never spill liquid of any kind onto or into this unit.
12. Except as specifically explained elsewhere in this manual, do not attempt to service this product yourself. Opening or removing covers that are marked "Do Not Remove" may expose you to dangerous voltage points or other risks, and will void your warranty. Refer all service issues to qualified service personnel.
13. Unplug this product from the wall outlet and refer to qualified service personnel under the following conditions:
 - a. When the power cord is damaged or frayed;
 - b. When liquid has spilled into the unit;
 - c. When the product has been exposed to rain or water;
 - d. When the product does not operate normally under normal operating conditions. Adjust only those controls that are covered by the operating instructions in this manual; improper adjustment of other controls may result in damage to the unit and may often require extensive work by a qualified technician to restore the unit to normal operation;
 - e. When the product has been dropped or the case has been damaged;
 - f. When the product exhibits a distinct change in performance, indicating a need for service.



GLASS - Handle with care

This product contains a sheet of 60/40 beam splitter glass, please handle it with care.

To avoid a risk of damage or injury please follow this instruction manual and use caution when transporting, un-packing, cleaning, assembling or dis-assembling this part of the product.

Warranty

Standard Warranty

- Datavideo equipment is guaranteed against any manufacturing defects for one year from the date of purchase.
- The original purchase invoice or other documentary evidence should be supplied at the time of any request for repair under warranty.
- Damage caused by accident, misuse, unauthorized repairs, sand, grit or water is not covered by this warranty.
- All mail or transportation costs including insurance are at the expense of the owner.
- All other claims of any nature are not covered.
- Cables & batteries are not covered under warranty.
- Warranty only valid within the country or region of purchase.
- Your statutory rights are not affected.

Two Year Warranty

- All Datavideo products purchased after 01-Oct.-2008 qualify for a free one year extension to the standard Warranty, providing the product is registered with Datavideo within 30 days of purchase. For information on how to register please visit www.datavideo-tek.com or contact your local Datavideo office or authorized Distributors
- Certain parts with limited lifetime expectancy such as LCD Panels, DVD Drives, Hard Drives are only covered for the first 10,000 hours, or 1 year (whichever comes first).

Any second year warranty claims must be made to your local Datavideo office or one of its authorized Distributors before the extended warranty expires.

Disposal



For EU Customers only - WEEE Marking

This symbol on the product indicates that it should not be treated as household waste. It must be handed over to the applicable take-back scheme for the recycling of Waste Electrical and Electronic Equipment. For more detailed information about the recycling of this product, please contact your local Datavideo office.

Packing List

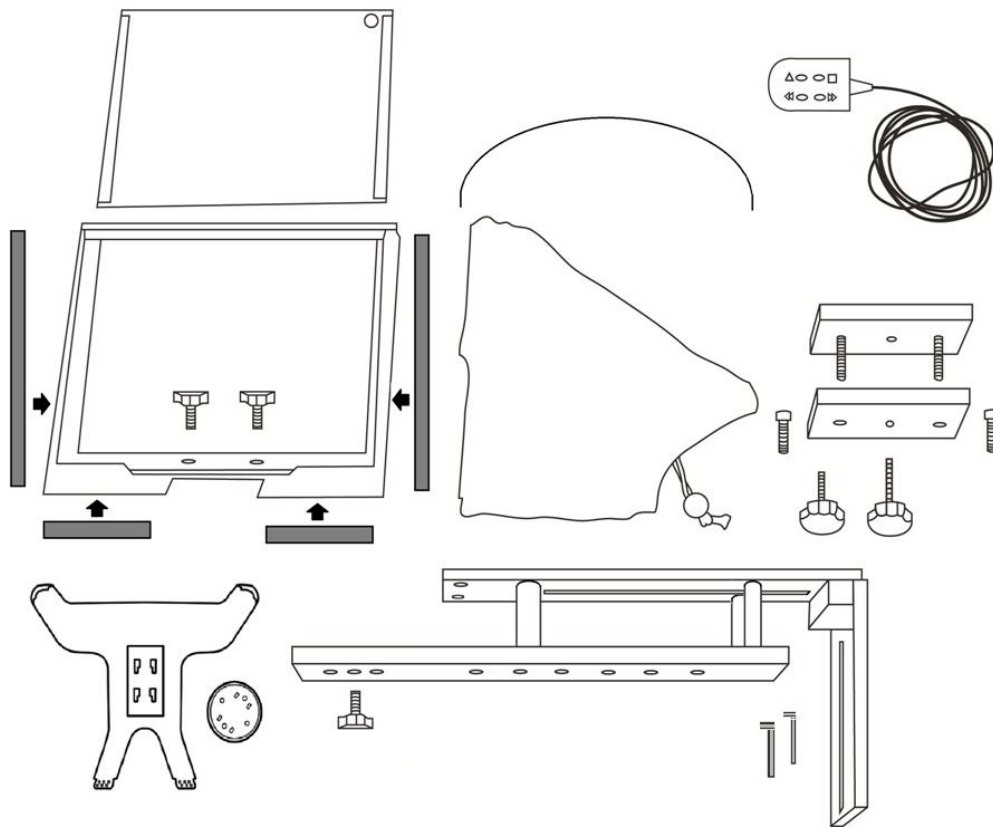

Item No.	Description	Quantity
1	Cloth Camera Snood/Hood with velcro straps	1
2	Glass Frame with matching Velcro straps	1
3	60/40 Glass sheet	1
4	Prompter Frame	1
5	Snood/Hood support wire	1
6	Mounting Bracket for iPad™	1
7	3mm Hex Screw length 14mm	2
8	2.5mm Hex Screw length 11mm	2
9	Hex Tools to tighten Frame screws	2
10	Wing nut Screw	3
11	Wired Remote Control	1
12	Camera Riser Blocks	2
13	Camera Riser Screw Long	1
14	Camera Riser Screw Short	1
15	Instruction Manual	1

Product Overview

Why struggle with expensive re-takes, on stage talent drifting off script or a presenters' loss of eye contact with the viewing audience? The Datavideo Prompter Kit, TP-200, is designed to help you overcome these problems by converting an Apple iPad™ (*not supplied*) into a low cost and effective prompter.

The Datavideo Prompter Kit TP-200 can be used in either a theatre setting, or a video studio. Prepared scripts or cue sheets can be easily copied and pasted into the DV prompter app software from email and scrolled at a set automatic rate or controlled by a user with the wired/wireless remote for a more natural result. A number of clear fonts, colours and text sizes are available making reading comfortable from a variety of distances.

Features

- Simple software and wired remote allow users to produce professional results at low cost.
- Special 60/40 Glass allows the presenter to read the script and the camera to see the subject.
- Strong and rigid prompter frame fixes securely to any standard tripod quick release plate.
- The prompter frame is designed to allow stand alone, in front of camera or below lens prompting.
- The black camera snood/hood is adjustable to adapt for a wide variety of cameras.
- Quick and simple assembly requires no special tooling.
- Flexible mounting bracket system allows simple but secure installation of iPad™/iPad2™.
- 3m long wired remote control perfect for self shoot projects.
- Optional wireless remote also available – please enquire with supplier.

Example Configurations
Normal Tripod Set Up

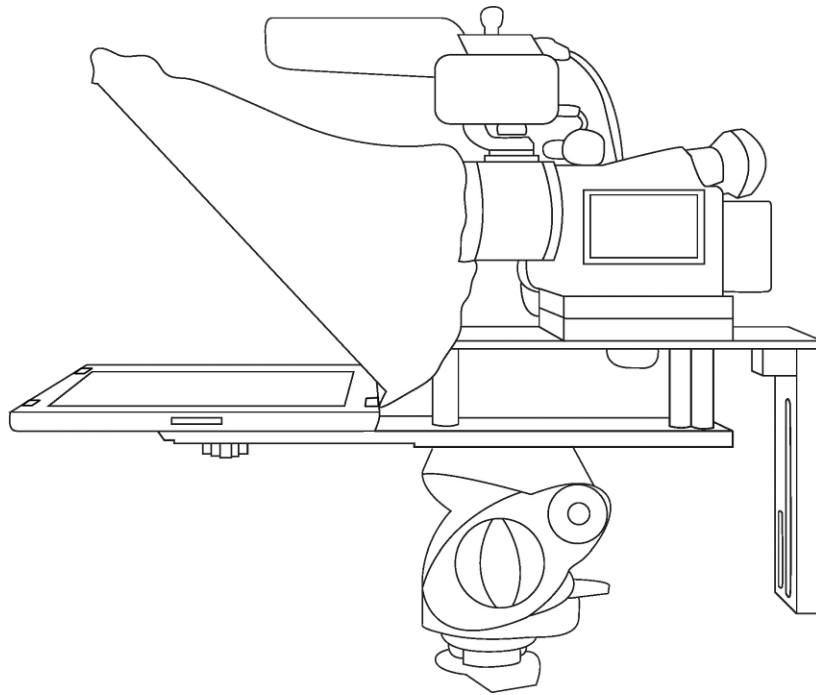

Below Camera Lens Set Up

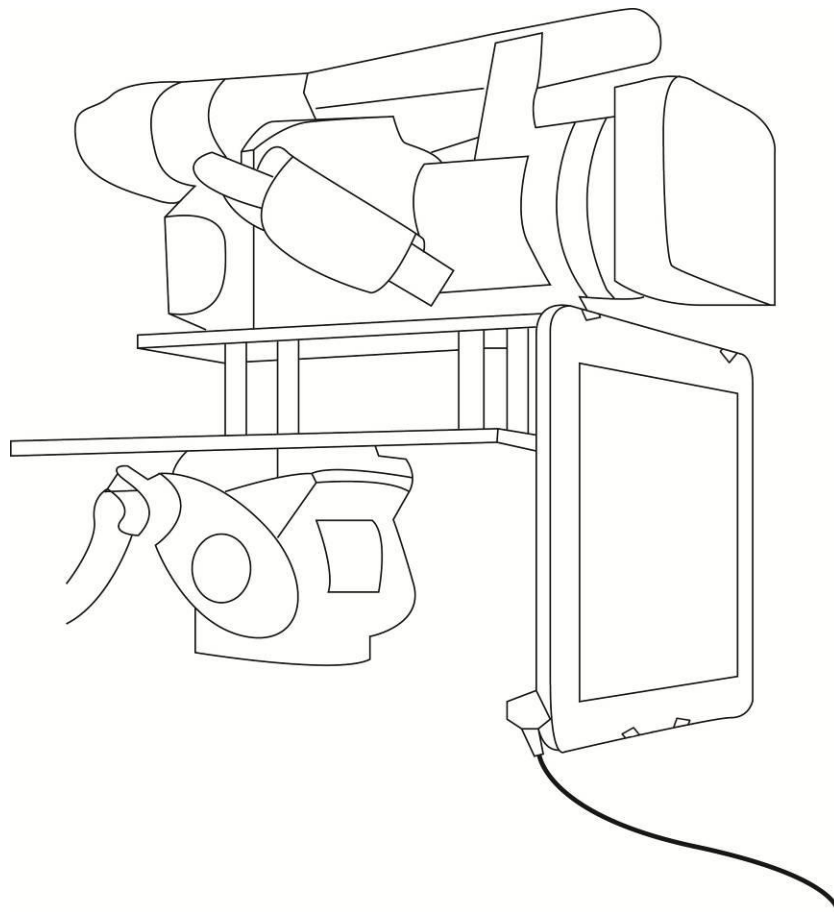

Assembly Normal Tripod Set Up

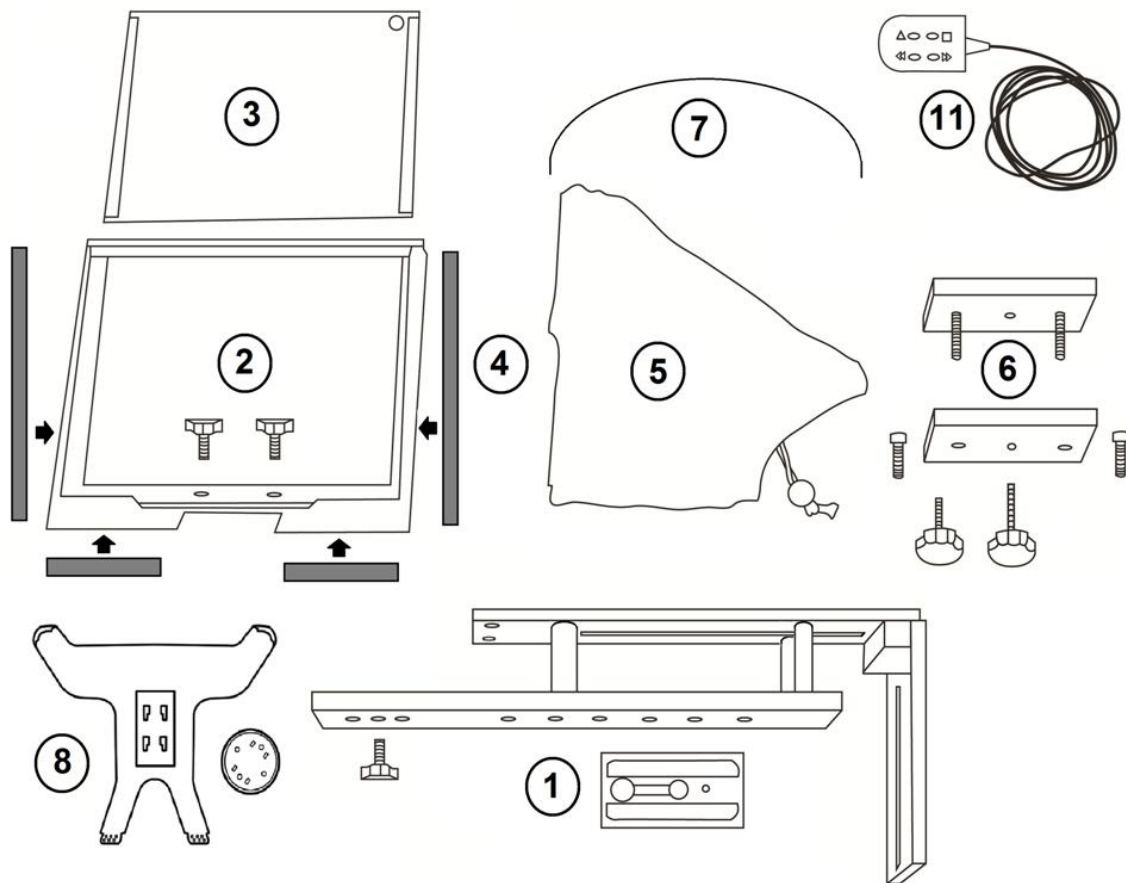

1. Attach/screw the tripod camera quick release plate to the screw holes on the base of the prompter frame. Then slide and secure tripod plate, with prompter frame on top, onto the head of the tripod.
2. Slide the Glass frame on to the upper part of the prompter frame (1) secure with two wing nut screws.
3. Guide/slide 60/40 Glass sheet into Glass frame with Red circle sticker facing camera position.
4. Apply the two long Velcro strips to the glass frame edges left side and right side. Now apply the two smaller Velcro strips to the bottom left and right sides of the glass frame edge.
5. Apply the black camera snood to Glass frame edges so the Velcro strips marry the snood to the frame.
6. Decide if camera riser blocks are required depending on the position of the camera lens. If using 1 block use the short hex screws through the block but leave the centre hole empty. Turn the block over so that screws project downwards and sit in the long top slot on the prompter frame.

7. Fit the camera riser screw with washer from below the top slot through the riser blocks centre hole and into the camera base so the camera is secure with prompter block and frame. Pull the draw cord to secure the black camera snood around the camera lens and to shut out light from camera side. Decide if the snood/hood support wire needs to be fitted.



8. Use the remaining wing nut screw to secure the mounting bracket for the iPad™ to the front of the Prompter frame's lower plate.
9. Turn on the iPad™ and launch the DV Prompter app then prepare the text to be used.
10. Put the iPad™ into the mounting bracket and ensure it is held securely.
11. Plug the wired remote control into headphone socket on the iPad™.
12. Adjust the DV Prompter app settings if necessary.
13. Adjust the camera exposure settings as necessary. See **Camera Exposure** below.
14. You should now be ready to start using the Prompter within your project.

Camera Exposure

After setting up the camera with the 60/40 glass in front of the lens adjust the camera set up and white balance. This is because the 60/40 Glass affects the camera exposure by approximately 1 stop almost like the effect of a neutral density filter. Consult your camera manual for further help and advice with its exposure and white balance settings.

Using Riser Blocks

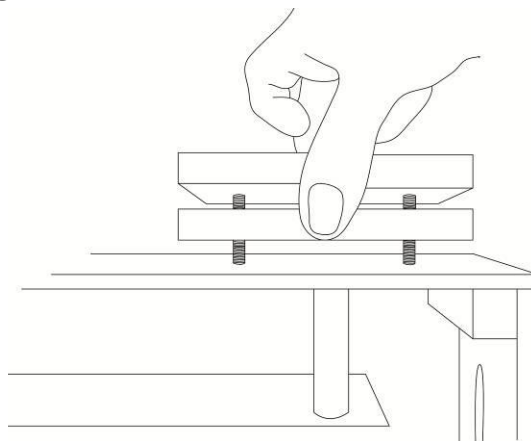

When using this TP-200 Prompter Kit you may need to use one or both riser blocks to raise the camera up so that the lens is positioned as near to the middle of the 60/40 Glass as possible.

Two sets of screws are supplied for use with these riser blocks. The longer screws are for use with two blocks and the shorter screws when using one block. In some cases the blocks are not required.

Below Lens Assembly

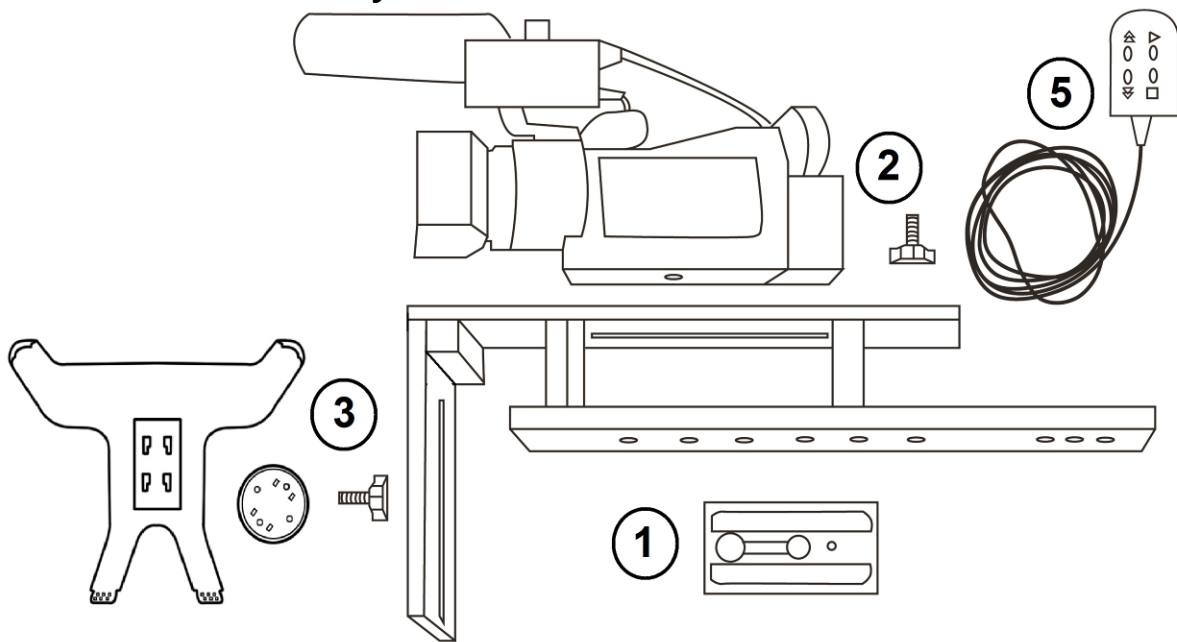

1. Attach/screw the tripod camera quick release plate to the screw holes on the base of the prompter frame. Slide and secure the tripod plate, with prompter frame on top, onto the head of tripod. Ensure the vertical plate of the prompter frame is facing toward the onscreen talent.
2. Fit the camera riser screw from below the prompter frame's long top slot. Marry the camera's base plate screw hole with Camera riser screw and secure the camera to the frame. Adjust position of the camera so the camera lens is at the edge of the prompter frame.
3. Use the small thumb screw to secure the mounting bracket for the iPad™ to the front of the Prompter frame's vertical plate.
4. Turn on the iPad™ and launch the DV Prompter app then prepare the text to be used. Slide the iPad™ into the mounting bracket and ensure everything is secure.
5. If using the wired remote control plug the remote into headphone socket on the iPad™.
6. Adjust the prompter settings as necessary.
7. You should now be ready to start using the Prompter within your project.

Software Download from the App Store™

Ensure your iPad™ has internet access via your cellular service provider or a secure wireless connection.



Tap the **App Store™ icon** on the iPad™ Home Screen to download apps wherever you are. **Browse** the section of the store that features apps designed specifically for the iPad™ or tap on the **Search bar** at the top/bottom of the screen and type in **Datavideo** or **DV Prompter**. Then execute the search by tapping on the Search icon to the right. You will see this software as a result listed, simply tap on the **Free** icon and then **Install**.



The App Store icon on iPad™ will show you when an update is available for any app that you already have. Install the updates with a tap, and you'll always have the latest version of your favourite apps like **DV Prompter**.

DV Prompter Application Set Up

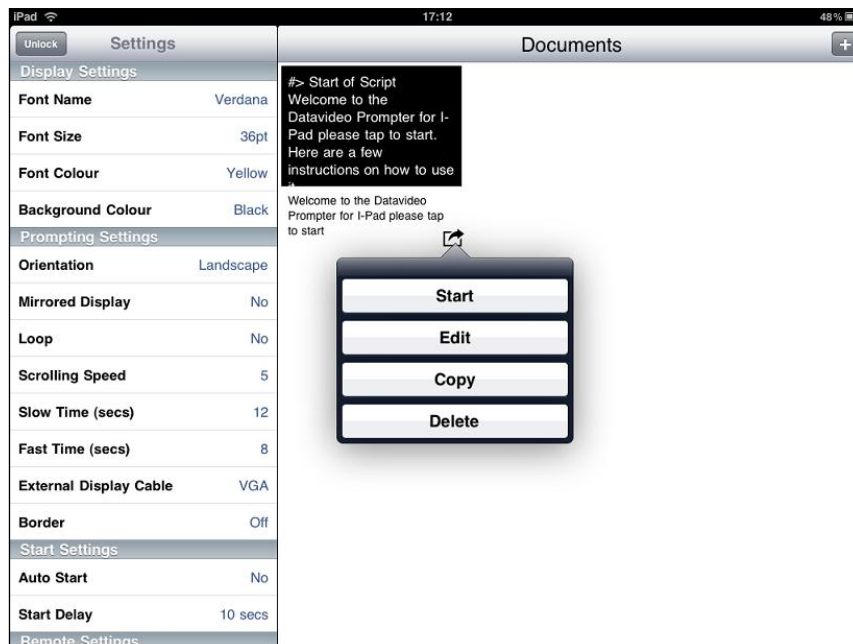

Display Settings

These settings allow the look of the text to be changed. You can change the **Font Name**, the pt (point) **Font Size** of the font, the **Font Colour** and the **Background Colour**.

The software initially defaults to White, Arial, 36pt size text on a Black Background. However, you can choose from the following text or background colours; White, Black, Red, Yellow, Blue, Green or Orange. All text will be displayed in the colour chosen. Currently you cannot have different colours for different sections of the text. The size of the text can range from small (9pt) to large (54pt). However, you need to experiment a little to find the text font and size that you, or your on-screen talent, can read comfortably at a distance away from the prompter or camera.

NB: The wired remote control supplied is approx. 3m long so this may be the maximum distance you want to work at on your own.

Prompting Settings

You use these settings to change the **Orientation** of the displayed text and if it will be **mirror** reflected off the 60/40 Glass or just used as a normal display. You can also set the text **Scrolling Speed** here, which can be slowed down or made faster with the wired remote control. A scrolling speed of 5 should be a good starting point. **Slow Time** and **Fast Time** are used to speed up or slow down the text scroll when using the speed buttons on the wired remote. If the on screen talent takes 5 to 15 seconds to read one page of text then set Slow Time to 15 seconds and the fast time to 5 seconds. Now when the speed buttons are pressed on the remote during text play back the speed will change in steps accordingly. There may be also options for connecting an external **VGA** or Composite monitor (additional adaptor cable required depending on your device) as well as switching the display **Border** function on or off.

Start Settings

You can set the prompter up to automatically start scrolling text straight away or you can delay the beginning of the text scroll process by up to 10 seconds after tapping on start.

Remote Settings

Here you can choose to use the wired remote and set up text characters that indicate a break in the scrolling text called **break markers**. These markers can then be used to quickly jump forward or backward between points in the text using the wired remote control should the running order of the production change.

Build Version

Only confirms the version of the software application being used.

Apple iPad™ Settings

Tip: Remember to turn the iPad™ Auto lock / Auto Sleep feature in its General Settings to 'Never' so this does not interrupt script reading when there may be very little interaction with the device's touch screen.

How to quickly add text into a DV Prompter document

The prompting script, or presenters' text, will probably exist as a text document from the planning stage of the production. By attaching this script text document to an email it can be quickly transferred to the iPad™ and into a DV prompter document by using the **Copy** and **Paste** function of the device itself.

Simply choose to edit an existing DV Prompter document and then save it as a new file name. This protects the original document from changes. Then replace the existing text in the newly saved file with the text that has been emailed to the iPad™.

Tidy up the transferred text as necessary, add some break markers and you have your newly created prompting document.

Importing a Text file via iTunes™

1. Connect your apple device to your PC or Mac via the apple USB cable
2. Launch iTunes™
3. Select your iPad™ under the Devices section in the left hand pane of iTunes™
4. Select the Apps tab at the top of the iTunes™ window
5. Scroll down to the bottom of the page and select DV PROMPTER from the FILE SHARING Apps menu.
6. Click the 'Add' button and browse for the text file you wish to import
7. Disconnect the apple device and restart DV PROMPTER, you should now see a new document in the list.

Using the wired Remote Control



Before you are able to use the wired remote you must first turn on the remote control feature within the prompter software.

Within the prompter software documents menu scroll down to and tap on the **Settings** option. Then choose **Remote Settings**; from here tap on **Remote Type** and then select the **Wired** remote option.

Note: A scrolling speed of 5 is a comfortable starting point for most people when using the remote. See also *Increase and Decrease speed buttons*.

Play Button

Use this green button to start the script scrolling.

Stop Button

Use this red button once to Pause the scrolling text. Press this button twice to Stop the script and bring up the menu bar. You can then exit the application, change text or change settings in the normal way using the iPad™ display.

Increase and Decrease Speed Buttons

These buttons allow the user to increase (arrows up) or decrease (arrows down) the scrolling text speed. Pressing these buttons allows you to vary the text scroll speed by 3 settings. For example; if you have the speed set initially at 5 then you could slow the text down 4, 3 then 2 or speed it up to 8.

Break Markers

The increase and decrease speed buttons can also be used to quickly jump forward or backwards through the script after the script has been stopped with the red button. The script should be marked in advance with break marker text characters to set logical points that the speaker may need to jump to should the running order of the production be changed at short notice.

Optional wireless remote available

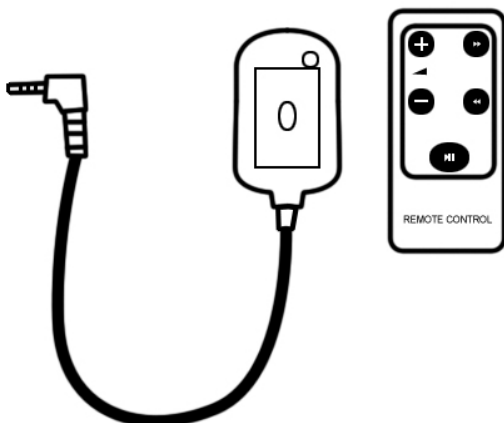

An optional wireless remote is available for this product. Please enquire about the price and availability of the wireless remote with your supplier.

Cleaning the 60/40 Glass sheet

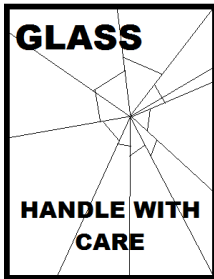

This product contains a sheet of 60/40 glass please handle it with care.

To avoid a risk of damage or injury please follow this instruction manual and use caution when transporting, un-packing, cleaning, assembling or dis-assembling this part of the product.

Datavideo recommend cleaning the glass regularly to remove dust and finger print marks. This will ensure the best image quality is recorded when the camera is looking through the glass.

Never attempt to clean the glass whilst it is mounted in the prompter set up instead remove it carefully from the rig, clean the glass and then re-install it into the prompter. Handle the glass carefully using the cloth covered edges of the glass at all times.

To retain the required qualities of the glass and to avoid scratching the glass during cleaning.

- **Never use** abrasive cloths, pads or abrasive based cleaning fluids on the glass.
- **Never use** cleaning fluids based on an acid or vinegar solution.

Place the glass on a soft, stable, dirt and lint free work surface such as a table with a clean cloth already laid out on it. Then use a second clean, lint free, soft cloth to clean the glass.

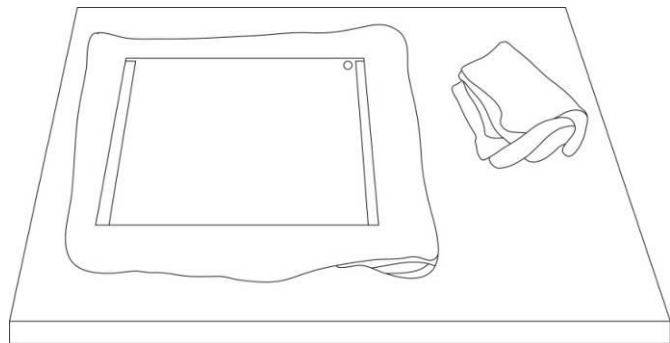

Do not apply cleaning fluids to the glass directly, instead apply or spray a small amount of the cleaning fluid onto the cloth.

Proceed to clean the glass and work in a light circular motion with the cloth. Ensure all finger marks and streaks are gone before turning the glass over and repeating with the other side.

Once finished re-install the glass back into the prompter frame, again using the cloth covered edges only. **Ensure the green circle sticker on the glass is facing you** and the red circle sticker is facing the camera lens. Reseat the camera sock cloth to the prompter frame if necessary.

Specifications

Text File Format	Copy and paste from email or text file
Reading Range	3m (9ft)
Prompter remote control cable length	3m (9ft)
iPad™ Max battery life	10 Hours or less
Prompter remote control battery life	2 years at average usage
Replacement remote control	Speak to Dealer or local Datavideo office

Rig Size

Width:	250 mm (9.84 inches)
Height:	210 mm (8.27 inches)
Depth:	447 mm (17.6 inches)

iPad Size

Width:	189.7 mm (7.47 inches)
Height:	242.8 mm (9.56 inches)
Depth:	13.4 mm (0.5 inch)

iPad2 Size

Width:	185.7 mm (7.31 inches)
Height:	241.2 mm (9.5 inches)
Depth:	8.8 mm (0.34 inch)

Nett Weight:

Kit:	4.2 lbs (1.9 Kg)
iPad:	1.6 lbs (0.73 Kg)
Combined:	5.8 lbs (2.63 Kg)

Packed weight: (Gross)

Kit:	6.18 lbs (2.8 Kg)
-------------	-------------------

Service and Support

It is our goal to make your products ownership a satisfying experience. Our support staff are available to assist you in setting up and operating your system. Please refer to our web site www.datavideo-tek.com for answers to common questions, support requests or contact your local office below.

Datavideo Global Website: www.datavideo-tek.com

Datavideo Corporation

Tel: +1 562 696 2324	Fax: +1 562-698-6930	E-Mail: contactus@datavideo.us
----------------------	----------------------	--

Datavideo Technologies Europe BV

Tel: +31-30-261-96-56	Fax: +31-30 261-96-57	E-Mail: service@datavideo.nl
-----------------------	-----------------------	--

Datavideo UK Limited

Tel: +44 1457 851 000	Fax: +44 1457 850 964	E-Mail: sales@datavideo.co.uk
-----------------------	-----------------------	--

Datavideo Technologies Co., Ltd

Tel: +886 2 8227 2888	Fax: +886-2-8227-2777	E-mail: service@datavideo.com.tw
-----------------------	-----------------------	--

Datavideo Technologies China Co., Ltd

Tel: +86 21-5603 6599	Fax: +86 21-5603 6770	E-mail: service@datavideo.cn
-----------------------	-----------------------	--

Datavideo Technologies (S) PTE Ltd

Tel: +65-6749 6866	Fax: +65-6749 3266	E-mail: sales@datavideo.sg
--------------------	--------------------	--

Datavideo HK Ltd

Tel: +852 2833 1981	Fax: +852-2833-9916	E-mail: info@datavideo.com.hk
---------------------	---------------------	--

All the trademarks are the properties of their respective owners.

Datavideo Technologies Co., Ltd. All rights reserved 2011.