

The Da-Lite Difference.

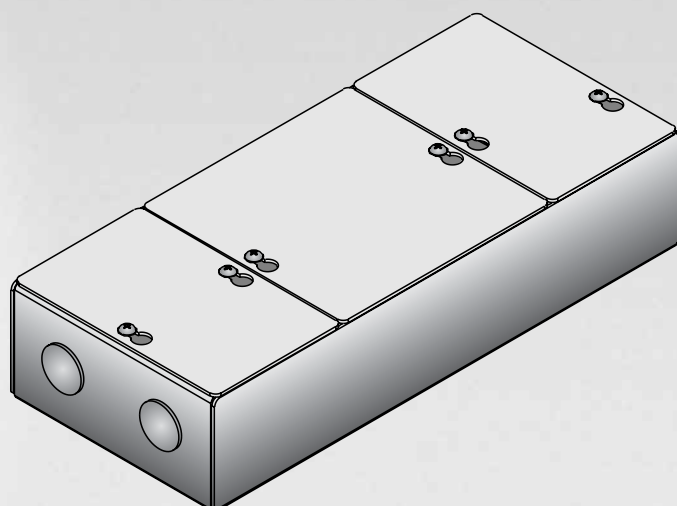

Installation and Operating Instructions For SINGLE MOTOR LOW VOLTAGE CONTROL SYSTEM



DA-LITE SCREEN COMPANY, INC.

3100 North Detroit Street
Post Office Box 137
Warsaw, Indiana 46581-0137
Phone: 574-267-8101
800-622-3737
Fax: 574-267-7804
www.da-lite.com
e-mail: info@da-lite.com

The low voltage control (LVC) housing is divided into 3 compartments. the compartment labeled “Low Voltage Connections” is where you will connect the wall switch or a central control panel. The compartment labeled “AC Power Connections” is where the main power and motor wire connections are made. The center compartment only requires access when connecting an infrared or radio frequency remote receiver.

INSTALLATION

WARNING: To prevent electrical shock or damage to the LVC, do not apply power to the LVC until all connections are complete. Make sure power is turned off on all wires before making connections.

LOW VOLTAGE CONNECTIONS:

Wall Switch

WARNING: This unit must be used with the enclosed switch. DO NOT USE the rocker switch included with screen.

1. Install wall switch where desired.
2. Use 3-conductor 20-24 gauge wire to extend the switch wire to the required length.
3. Connect the wire from the switch to the wire labeled “wall switch”. Refer to diagram 1.



CAUTION: Never apply voltage to the wall switch lead or the LVC will be damaged.

Control Panel

A control panel may be connected to the LVC by using the wall switch wire lead. The control panel must provide a momentary, dry contact closure of at least 1/2 second.

1. Use 3-conductor 20-24 gauge wire to connect the control panel to the wall switch lead.
2. A momentary closure across the white and red wires will be an “up” command.
3. A momentary closure across the white and black wires will be a “down” command.
4. A momentary closure across the white, red and black wires will be a “stop” command.



CAUTION: Never apply voltage to the wall switch lead or the LVC will be damaged.

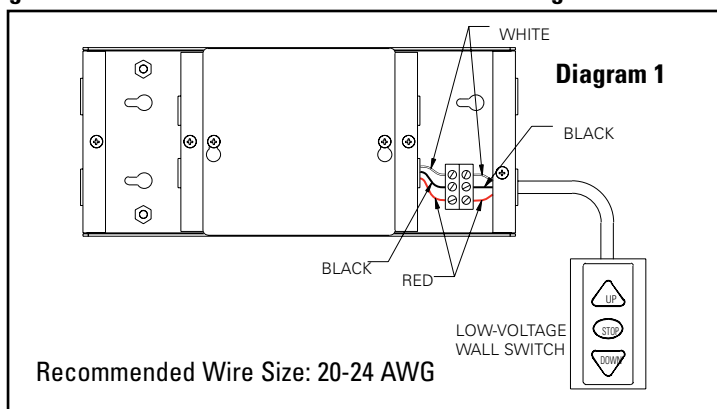

AC POWER CONNECTIONS:

Screen Motor

1. Connect the motor wires in the screen junction box to the LVC wires labeled “motor wires”. Refer to diagram 2.
2. Use 14-18 gauge wire to extend the motor wire to the required length.

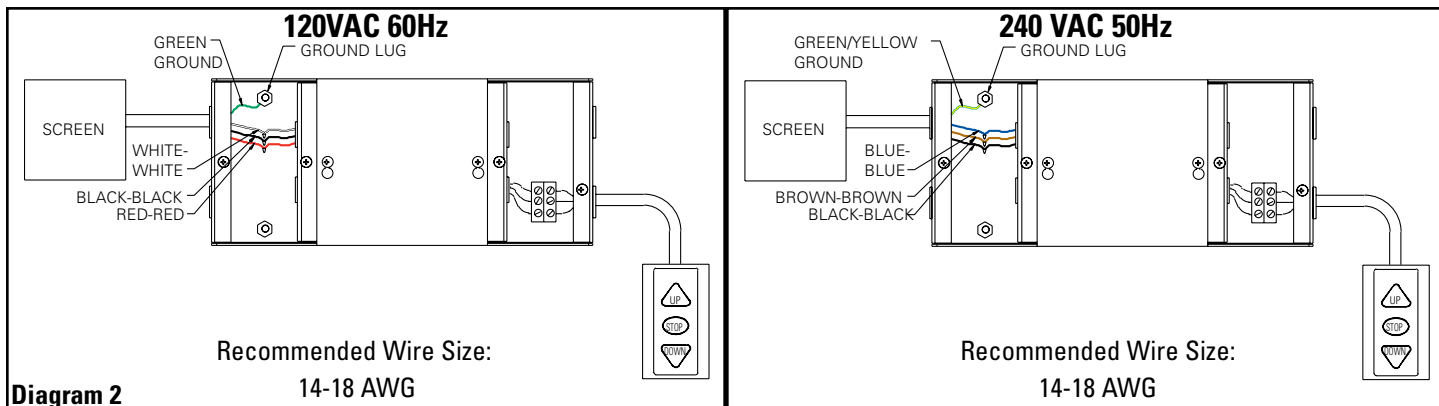

INSTALLATION

AC Power Source

1. Connect power wires to the LVC wires labeled "AC power input". Refer to diagram 3.
2. Connect the building ground wire to the ground lug on the metal housing.

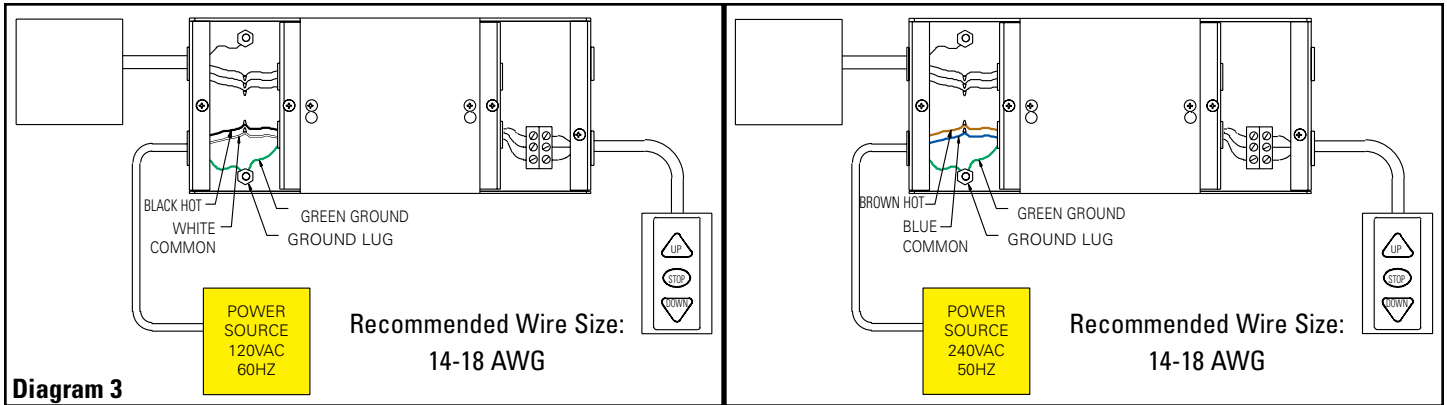

OPTIONAL WIRELESS REMOTE CONNECTIONS:

Radio Frequency Remote

1. Remove the cover plate labeled "Low voltage connections" and the center cover plate.
2. Route the receiver wire through the round plastic bushing and plug it into the onboard socket marked "EYE". Refer to diagram 4.

Infrared Remote

1. Remove the cover plate labeled "Low voltage connections" and the center cover plate.
2. Route the receiver wire through the round plastic bushing and plug it into the onboard socket marked "EYE". Refer to diagram 4.

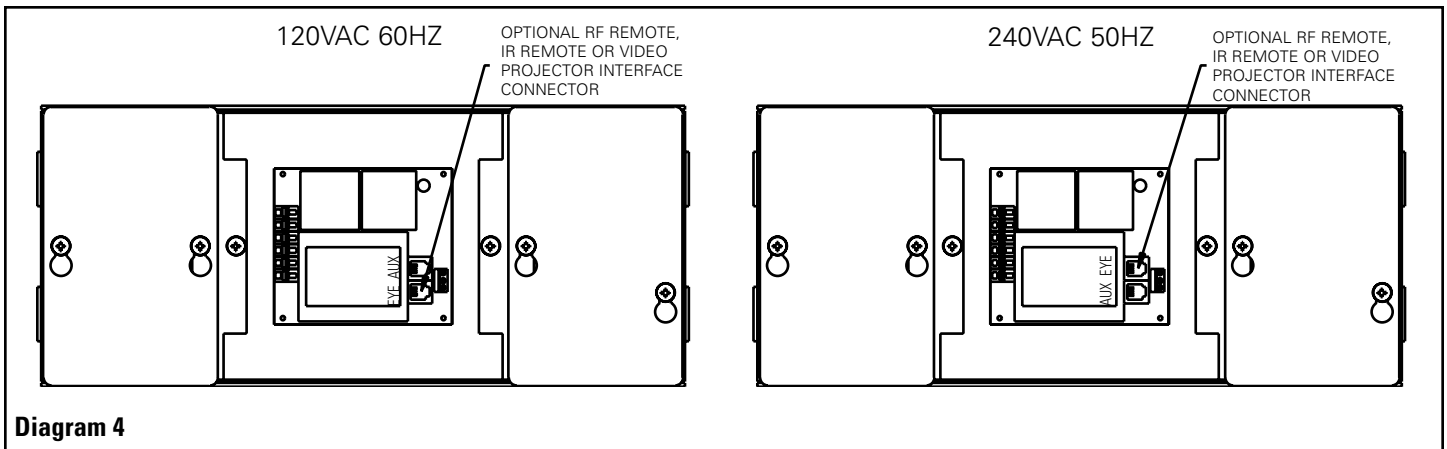

TROUBLESHOOTING

Visit www.da-lite.com/products/tutorials.php to find installation and troubleshooting tutorials. You will also find a link to Live Chat for interactive support and you can contact us by email at info@da-lite.com or by phone at (800) 622-3737 or (574) 267-8101 with any troubleshooting questions.

SYMPTOM	CAUSE	SOLUTION
1. Screen will not operate.	<ul style="list-style-type: none"> (a) No power to LVC unit. (b) Incorrect wiring. (c) Low voltage circuit damaged due to voltage input. (d) LVC controller lock-up 	<ul style="list-style-type: none"> (a) Turn on power to LVC input. Measure voltage across black and white input leads. (b) Recheck all wiring for proper installation. Check all wire nut connections. (c) The wall switch terminal is for dry contact (no voltage) input only. Applying voltage to this terminal will damage the LVC. (d) Locate breaker for screen and turn off power. Wait one minute and re-activate circuit.
2. Radio frequency remote does not work.	<ul style="list-style-type: none"> (a) Weak battery in transmitter. 	<ul style="list-style-type: none"> (a) Replace battery.
3. Infrared remote does not work.	<ul style="list-style-type: none"> (a) Weak battery in transmitter. (b) Receiver incorrectly positioned. (c) Fluorescent light interference. 	<ul style="list-style-type: none"> (a) Replace battery. (b) Receiver must be unobstructed and located in direct line with the transmitter. (c) Remote receiver should not be placed near fluorescent lights.
4. Screen runs in the wrong direction.	<ul style="list-style-type: none"> (a) Red and black wires are reversed on motor or wall switch terminals. 	<ul style="list-style-type: none"> (a) Turn off power to LVC. Reverse the red and black wires on either the motor terminals or the wall switch terminals. Changing either one will change the direction of motor travel. Do not change both.

NOTE: The LVC will shut off power to the screen motor 5 minutes after the motor stops turning. Push the up or down button to reactivate the LVC relays.