



* images for illustration purposes only

Product Description

The Tannoy SR601T is a high power handling, high sensitivity, full bandwidth rock speaker design primarily for outdoor use. The rugged and durable terra alba and fibreglass enclosure is weather, water marking and UV discolouration resistant, to IP64 specification. This, together with the integrated grille design, provides protection for the 153mm (6.00") Tannoy ICT™ transducer from the elements, including rain, hail, sleet, snow and high salt content atmospheres.

Now available in three colours – Grey, Green and Sand - the natural rock-like appearance of the SR601T blends inconspicuously into most outdoor applications including gardens, patios, and architectural landscapes.

To allow for multiple units to be installed in a distributed system, such as in theme parks, large civic gardens, etc. the SR601T has an integral low insertion loss 30W line transformer with an easily accessible rotary tapping switch to select between low impedance and 70V or 100V operation:

70V: 30W / 15W / 7.5W / 3.75W / 1.9W & low impedance operation
100V: 30W / 15W / 7.5W / 3.75W & low impedance operation.

Anchor points are also integrated into the design to allow for secure installation, even on uneven or inclined surfaces, or in areas subjected to high winds such as coastal locations.

Equipped with Tannoy's exclusive ICT™ point source, constant directivity drive unit, the SR601T delivers an acoustic performance of outstanding clarity, definition and detail with class leading vocal intelligibility. The mid bass and tweeter sections of the driver are configured to a point source, ensuring a wide and controlled dispersion for optimum coverage of the listening area. The ICT™ drive unit design also addresses the two most common component failures experienced in background music and sound reinforcement systems, the tweeter and the crossover reliability. The use of a wireless electromagnetic tweeter means that no crossover is required in the design; this therefore ensures that an ICT™ unit cannot be burned out through system misuse or by constant heavy usage. The mineral loaded polypropylene cone material and nitrile rubber surround further enhance durability and long-term reliability.

Features

- 153mm (6.00") ICT™ driver
- IP64-rated weather resistant enclosure
- Available in 3 different colours
- Phase coherent design for superior vocal articulation and music reproduction
- No crossover required, ensuring better phase, impedance and sensitivity response for high performance and durability
- Wireless electromagnetic tweeter cannot be burned out from heavy or abusive use
- 1 metre of weather resistant speaker attached
- Integral low insertion loss 30W transformer
- Five year loudspeaker warranty
- 3 anchor points for secure location.

Applications

- Architectural landscapes
- Residential developments, gardens and patios
- Retail outlets, boutiques and shopping malls
- Lounges and theme bars
- Airports
- Theme parks and convention centres
- Casinos
- Museums
- Transport Hubs
- Cruise ships
- Recreational facilities

Tannoy United Kingdom
Tannoy North America
Tannoy Deutschland
Tannoy France

T: 00 44 (0) 1236 420199
T: 00 1 (519) 745 1158
T: 00 49 (180) 1111 881
T: 00 33 (0)1 7036 7473

E: enquiries@tannoy.com
E: inquiries@tannoyna.com
E: anfragen@tannoy.com
E: ventes@tannoy.com

tannoy®.com



SR601T

TANNOY®

TECHNICAL SPECIFICATIONS

System

Frequency Response ⁽¹⁾ 80Hz - 20kHz (+/-5dB),
(-10dB) 60Hz

Directivity Index

1kHz 4.2
2kHz 6.1
4kHz 10.1
8kHz 7.0
16kHz 9.8

Q

1kHz 2.6
2kHz 4.1
4kHz 10.3
8kHz 5.1
16kHz 9.6

Rated Maximum SPL ⁽²⁾ 107dB average
110dB peak

Impedance 6 Ohms

Crossover Frequency 7kHz (Inductively Coupled)

Power Handling 60 Watts (average)

Sensitivity 87dB

Transducer

Full Range 1 x 153mm (6") ICT™ transducers

Transformer Taps (via rotary switch)

70V 30W / 15W / 7.5W / 3.75W / OFF
& low impedance operation
100V 30W / 15W / 7.5W / OFF & low
impedance operation

Construction

Enclosure Terra alba & fibre glass
Weather resistant

Grille Material Stainless steel

Connection 1m weather proof speaker cable

Dimensions (H x W x D) 275mm x 295mm x 270mm
(10.8" x 11.6" x 10.6")

Net Weight 4.5kgs (9.9lbs)

Fittings 3 x anchor points

Ordering Information

PART NUMBER	MODEL NAME	COLOUR	PACKED QUANTITY
8001 4661	SR601T	GREEN	1
8001 4662	SR601T	SAND	1
8001 4663	SR601T	GREY	1

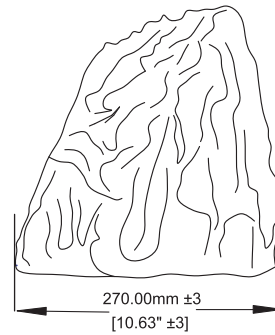
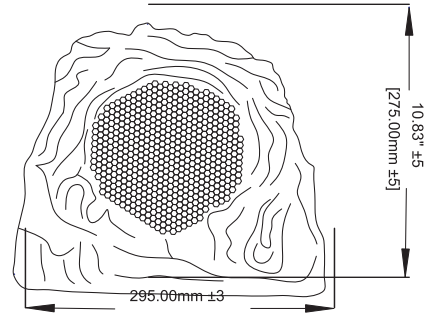

Architectural Specifications

The weather resistant, full bandwidth outdoor rock-design speaker system shall consist of a 153mm (6.00") full range, point source ICT™ transducer mounted in an optimally tuned, rugged and durable terra alba / fibreglass enclosure. The enclosure construction with integrated protective grille shall provide weather, water marking and UV discolouration resistance.

Performance of the SR601T speaker shall meet or exceed the following criteria: Frequency response measured on axis shall be 80Hz - 20kHz (+/-5dB), (-10dB) 60Hz; unweighted pink noise input measured at 1m in an anechoic chamber. Sensitivity shall be 87dB (1W = 2.45V for 6 Ohms). Long term power handling capacity as defined in EIA-426B test shall be 60W, recommended amplifier power 120W. The nominal system impedance shall be 6 Ohms (in low impedance setting).

One metre of weather resistant speaker cable shall be provided hardwired into the enclosure.

The dimensions shall be: Height 275 ±5 x width 295 ±3 x 280 ±3mm (Height 10.83 ±5 x width 11.61 ±3 x 11 ±3")

The outdoor rock-design speaker system shall be the.....SR601T.

Notes:

- (1) Unweighted pink noise input measured at 1m in an anechoic chamber
(2) Averaged over stated bandwidth, measured at 1m on axis

A full range of measurements, performance data, and Ease™ Data can be downloaded from www.tannoy.com

Tannoy operates a policy of continuous research and development. The introduction of new materials or manufacturing methods will always equal or exceed the published specifications, which Tannoy reserves the right to alter without prior notification.

Tannoy United Kingdom
Tannoy North America
Tannoy Deutschland
Tannoy France

T: 00 44 (0) 1236 420199
T: 00 1 (519) 745 1158
T: 00 49 (180) 1111 881
T: 00 33 (0)1 7036 7473

E: enquiries@tannoy.com
E: inquiries@tannoyna.com
E: anfragen@tannoy.com
E: ventes@tannoy.com

tannoy.com