

Smart Solutions™ Series

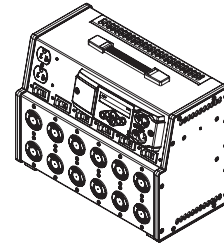

GENERAL INFORMATION

SmartModule 2 is ETC's latest innovation in the Smart Solutions family, giving you next generation dimming for portable or permanent installations without busting your budget.

Set up your system and light like a pro. Just plug in and play anytime, anywhere.

APPLICATIONS

- Applications requiring distributed dimming and position flexibility:
 - Industrial productions
 - Rental productions
 - Convention and conference centers
 - Museums
 - Casinos
 - Discos
 - Multi-use venues: Gymnasiums
Cafeteriums
Multimedia rooms

FEATURES

- Convection cooled
 - No fans required
- Resettable 1200 watt (10A) breaker output protection
- One duplex Edison convenience outlet
- RDM Enabled
 - DMX512A w/RDM Remote Addressing
- Smart User Interface
 - Graphic level display
 - Quick setup menus
 - Button shortcut for manual control
 - User-selectable dimmer curves
 - 20 chases (preprogrammed sequences)

ORDERING INFORMATION

SmartModule 2 Accessories

MODEL	DESCRIPTION
400CC	C-Clamp
U-BOLT	U-bolt kit
400SC	Safety Cable
SM4-WB	4 circuit SmartModule 2 Wall Mount kit
SM4-PB	4 circuit SmartModule 2 Pipe Mount kit
SM6-WB	6 circuit SmartModule 2 Wall Mount kit
SM6-PB	6 circuit SmartModule 2 Pipe Mount kit

*Clamps and u-bolts sold separately for pipe mount kit.

ORDERING INFORMATION

SmartModule 2

MODEL	DESCRIPTION
SM4-10-A	4 circuit SmartModule 2, 1x20A Cable In, Dual Edison Out
SM4-10-B	4 circuit SmartModule 2, 1x20A Cable In, Stage Pin Out
SM4-10X-A*	4 circuit SmartModule 2, Bi-phase (2 x 20A) Single Cable in, Dual Edison Out
SM4-10X-B*	4 circuit SmartModule 2, Bi-phase (2 x 20A) Single Cable in, Stage Pin Out
SM6-10X-A*	6 circuit SmartModule 2, Bi-phase (2 x 20A) Single Cable in, Dual Edison Out
SM6-10X-B*	6 circuit SmartModule 2, Bi-phase (2 x 20A) Single Cable in, Dual Stage Pin Out
SM6-10X-C*	6 circuit SmartModule 2, Bi-phase (2 x 20A) Single Cable in, Dual Twist-Lock® Out
SM6-10X-V*	6 circuit SmartModule 2, Bi-phase (2 x 20A) Single Cable in, Dual Veam Out
SM6-10Y-A*	6 circuit SmartModule 2, 3-phase cable in, Dual Edison Out
SM6-10Y-B	6 circuit SmartModule 2, 3-phase cable in, Stage Pin Out
SM6-10Y-C	6 circuit SmartModule 2, 3-phase cable in, Dual Twist-Lock Out
SM6-10Y-V	6 circuit SmartModule 2, 3-phase cable in, Dual Veam Out
SM6-10Z-A	6 circuit SmartModule 2, 3-phase GTL in, Dual Edison Out
SM6-10Z-B	6 circuit SmartModule 2, 3-phase GTL in, Dual Stage Pin Out
SM6-10Z-C	6 circuit SmartModule 2, 3-phase GTL in, Dual Twist-Lock Out
SM6-10Z-V	6 circuit SmartModule 2, 3-phase GTL in, Dual Veam Out

Note: Bi-Phase SmartModules are supplied with a single 12/4 50 cable.

* (-10X) Bi-phase models split Auxiliary, 1, and 2 circuits on phase 1 with circuits 3-6 on incoming phase 2.



SPECIFICATIONS

GENERAL

- Four or six dimmer versions available
- 1200 watt max per channel output
- UL / cUL Listed
- Installation requires attachment of a safety cable, data via DMX, and main power input using your choice of a panel mount connector or a flexible cable

MECHANICAL

- Manufactured of strong, thick walled aluminum with a black baked powder-coat finish
- Integrated handle for ease of carrying
- Convection cooled - operates without cooling fans or filters
- Stackable six circuit - conveniently designed to stack vertically in storage

ELECTRICAL

- Input power feed - 20A max per phase
- 85-140VAC phase to neutral 47-63Hz
- Four Circuit - choice of power entry
 - Single 12/3 SO cable for 120V hot/neutral/ground feed
 - Single 12/4 SO cable for 120/240V single (bi/2) phase feeds
- Six Circuit - choice of power entry
 - Single 20A 3 phase panel mounted L21-20 Twist-Lock
 - Single 10/5 SO cable for 120/208V three phase feeds
 - Single 12/4 SO cable for 120/240V single (bi/2) phase feeds
- Cable input models- Power via an attached flexible 12' SO cable with bare-ends (connector not supplied)
- 2500V isolation between control and power components
- Dual SCR forward phase dimming
- Total load can not exceed capacity of main power connection (wall outlet, 15A, 20A per phase)
- 75W minimum load per dimmer
- Dual Edison, Stage Pin or Twist-Lock outlets (1 per circuit)
- Single duplex auxiliary outlet
- 10A magnetic supplemental circuit breaker for each output

THERMAL

- Maximum ambient temperature of 104°F (40° C)
- Humidity between 10 - 95% non-condensing
- Convection cooled
- Optimum cooling when mounted horizontally

SPECIFICATIONS

CONTROL FEATURES

- DMX512 In and Thru via 5 Pin XLR connectors
- Supports up to 32 SmartModule 2 units on one DMX line
- High contrast 2-line by 20-character backlit LCD with graphic channel level indication
- Six-button Smart style keypad
- Two status indicators: Power and Valid DMX
- Soft patch any dimmer to any DMX channel
- Five selectable dimmer output curves:
 - IES modified square law
 - Linear
 - Switched (50% threshold)
 - Fluorescent with adjustable cut-off
 - Adjustable Pre-Heat
- Local manual control and 20 built-in chase patterns for stand alone operation
- Multi-Language capability - English, Spanish, German, and French

PHYSICAL

SmartModule 2 Dimensions*

MODEL	HEIGHT		WIDTH		LENGTH	
	inches	mm	inches	mm	inches	mm
SM2-4	8	203	13	330	6	152
SM2-6	10.5	267	15	381	7.25	184

SmartModule 2 Weights*

MODEL	WEIGHT		SHIPPING WEIGHT	
	lbs	kg	lbs	kg
SM2-4	15.6	7.1	17	7.7
SM2-6	23.7	10.75	27.9	12.65

*Weights and dimensions typical

SM2-4

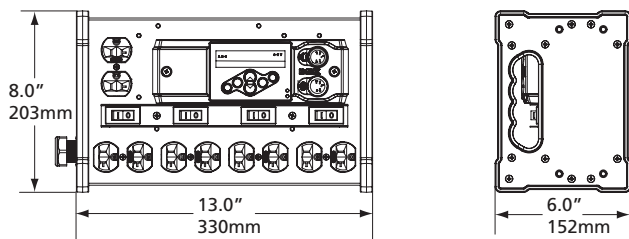

SM2-6

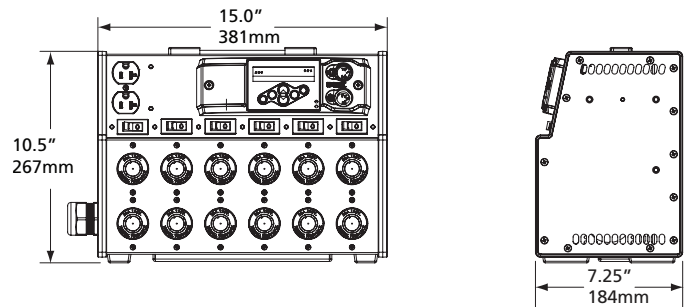

Corporate Headquarters • 3031 Pleasant View Rd, PO Box 620979, Middleton WI 53562 0979 USA • Tel +1 608 831 4116 • Fax +1 608 836 1736
 London, UK • Unit 26-28, Victoria Industrial Estate, Victoria Road, London W3 6UU, UK • Tel +44 (0)20 8896 1000 • Fax +44 (0)20 8896 2000
 Rome, IT • Via Pieve Torina, 48, 00156 Rome, Italy • Tel +39 (06) 32 111 683 • Fax +44 (0) 20 8752 8486
 Holzkirchen, DE • Ohmstrasse 3, 83607 Holzkirchen, Germany • Tel +49 (80 24) 47 00-0 • Fax +49 (80 24) 47 00-3 00
 Hong Kong • Room 1801, 18/F, Tower 1 Phase 1, Enterprise Square, 9 Sheung Yuet Road, Kowloon Bay, Kowloon, Hong Kong • Tel +852 2799 1220 • Fax +852 2799 9325
 Web • www.etcconnect.com • Copyright©2011 ETC. All Rights Reserved. All product information and specifications subject to change. 7543L1002 Rev. C Printed in USA 3/11