

LD-1 Light Ring Controller and Dual Colour Light Ring

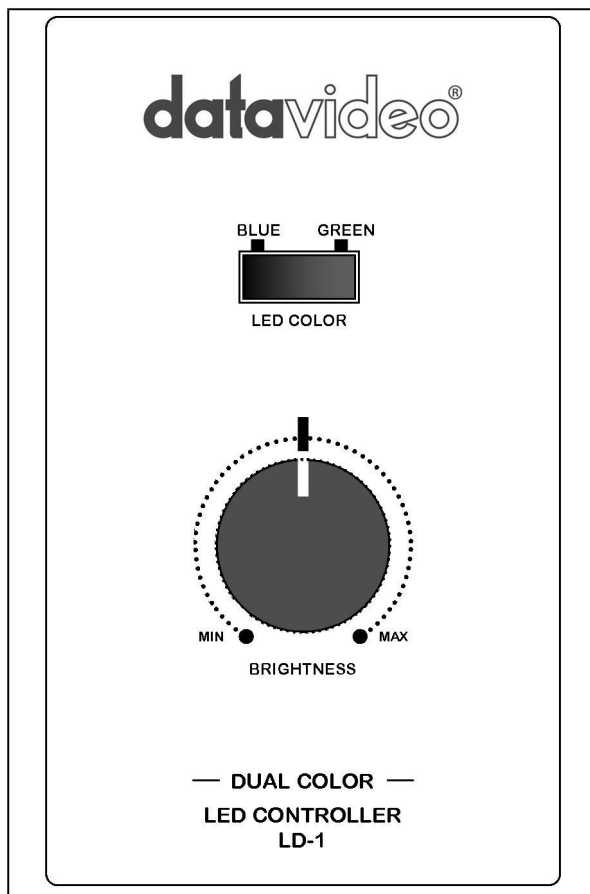

Instruction Manual

Table of contents

Warnings and Precautions	2
Warranty	3
Disposal	3
Packing List	3
Introduction	4
Features	4
Connections & Controls	5
LD-1 Top Panel	5
LD-1 Front Panel	6
LD-1 Rear Panel	7
Operating with the Datavideo DVK-100 Mk II	7
External Control	8
Light Ring	9
Specification	11
Service and Support	12



Warnings and Precautions

1. Read all of these warnings and save them for later reference.
2. Follow all warnings and instructions marked on this unit.
3. Unplug this unit from the wall outlet before cleaning. Do not use liquid or aerosol cleaners. Use a damp cloth for cleaning.
4. Do not use this unit in or near water.
5. Do not place this unit on an unstable cart, stand, or table. The unit may fall, causing serious damage.
6. Slots and openings on the cabinet top, back, and bottom are provided for ventilation. To ensure safe and reliable operation of this unit, and to protect it from overheating, do not block or cover these openings. Do not place this unit on a bed, sofa, rug, or similar surface, as the ventilation openings on the bottom of the cabinet will be blocked. This unit should never be placed near or over a heat register or radiator. This unit should not be placed in a built-in installation unless proper ventilation is provided.
7. This product should only be operated from the type of power source indicated on the marking label of the AC adapter. If you are not sure of the type of power available, consult your Datavideo dealer or your local power company.
8. Do not allow anything to rest on the power cord. Do not locate this unit where the power cord will be walked on, rolled over, or otherwise stressed.
9. If an extension cord must be used with this unit, make sure that the total of the ampere ratings on the products plugged into the extension cord do not exceed the extension cord's rating.
10. Make sure that the total amperes of all the units that are plugged into a single wall outlet do not exceed 15 amperes.
11. Never push objects of any kind into this unit through the cabinet ventilation slots, as they may touch dangerous voltage points or short out parts that could result in risk of fire or electric shock. Never spill liquid of any kind onto or into this unit.
12. Except as specifically explained elsewhere in this manual, do not attempt to service this product yourself. Opening or removing covers that are marked "Do Not Remove" may expose you to dangerous voltage points or other risks, and will void your warranty. Refer all service issues to qualified service personnel.
13. Unplug this product from the wall outlet and refer to qualified service personnel under the following conditions:
 - a. When the power cord is damaged or frayed;
 - b. When liquid has spilled into the unit;
 - c. When the product has been exposed to rain or water;
 - d. When the product does not operate normally under normal operating conditions. Adjust only those controls that are covered by the operating instructions in this manual; improper adjustment of other controls may result in damage to the unit and may often require extensive work by a qualified technician to restore the unit to normal operation;
 - e. When the product has been dropped or the cabinet has been damaged;
 - f. When the product exhibits a distinct change in performance, indicating a need for service.

Warranty

Datavideo warrants that the equipment it manufactures shall be free from defects in material and workmanship for a period of 12 months from the date of product purchased. If equipment fails due to such defects, Datavideo will, at its option, repair or provide a replacement for the defective part or product. Equipment that fails after the warranty period, has been operated or installed in a manner other than that specified by Datavideo, or has been subjected to abuse or modification, will be repaired for time and material charges at the Buyer's expense.

This warranty does not affect your statutory rights within the Country of purchase.

Disposal

For EU Customers only - WEEE Marking.



This symbol on the product indicates that it will not be treated as household waste. It must be handed over to the applicable take-back scheme for the recycling of electrical and electronic equipment. For more detailed information about the recycling of this product, please contact your local Datavideo office.

Packing List:

The following items should be included in the box. If any items are missing please contact your supplier.

1	x	LD-1 LED Controller
1	x	Dual Colour Light Ring with 72mm Thread Mounting Ring
1	x	1.5 ψ Allen Key
2	x	GPI Cable 3.5mm Plug to 3.5mm Plug (1.2m)
1	x	Remote Control Cable Mini 3 Pin Din to 3 x Spade End (2m)
1	x	S-Video Plug to S-Video Plug Cable (20cm)
1	x	Power Supply (12V 1.5A)
1	x	Instruction Manual

Introduction

The Datavideo LD-1 is a Dual Colour Light Ring and LED controller for Chroma Key Studios. It is intended for use with a Retro Reflective Backcloth such as Datavideo RF-3025.

It can be used in conjunction with the Datavideo DVK-100 Mk II and offers automated switching.

N.B. If you own a DVK-100 and you are unsure whether it is Mk I or Mk II please check the serial no. - Mk II will be 00097180 or higher. If your DVK-100 is Mk I please contact your local Datavideo Office for details of how to get it upgraded.

Using a light ring differs slightly to conventional chroma keying. A typical set up with a Retro Reflective Cloth and Light Ring would be something like this:

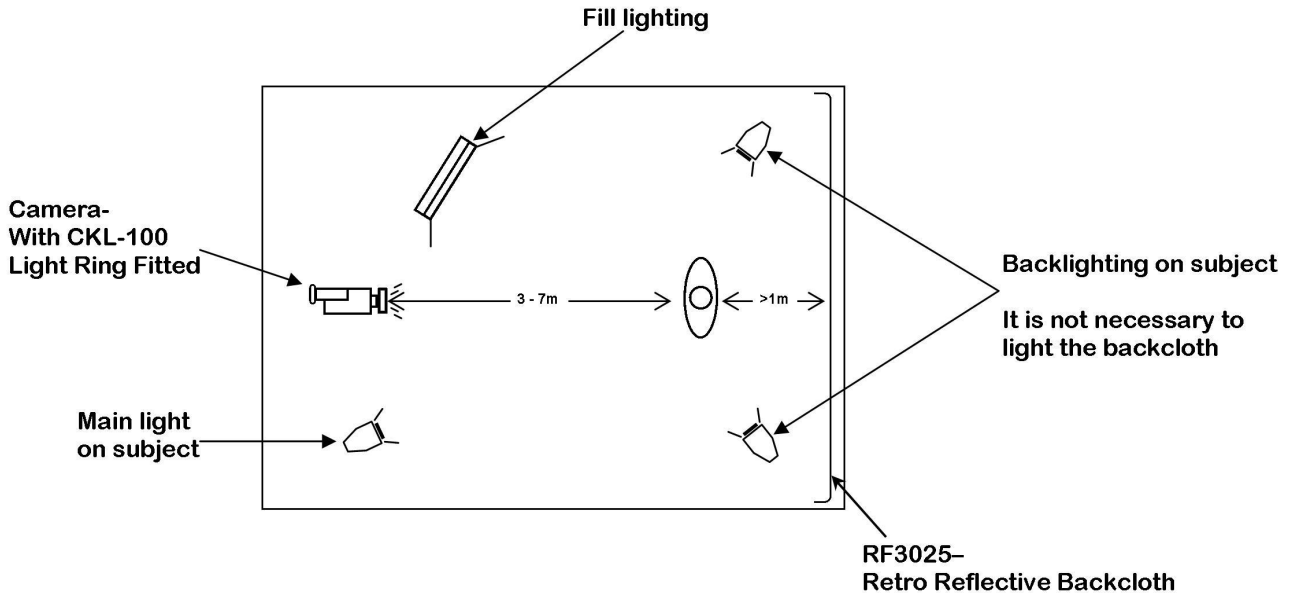

Unlike conventional Chroma Key Studios it is not necessary to light the backcloth, in fact it is better not to. It is best to have the camera between 3 and 7 metres from your subject, and your subject at least 1 metre from the backcloth. Providing some backlight on your subject will generally improve the keying effect, but you can play around with your light set up to get the required feel to the shot.

We would recommend that you do not work outside, the lighting is too variable and a consistent result will be hard to achieve.

Features

Blue / Green switching via Local or Remote Control via GPI or Datavideo DVK-100 MkII Two Channel Chroma Keyer

Switching Control of Datavideo DVK-100 MkII Two Channel Chroma Keyer

Variable Output

Connections & Controls Top Panel

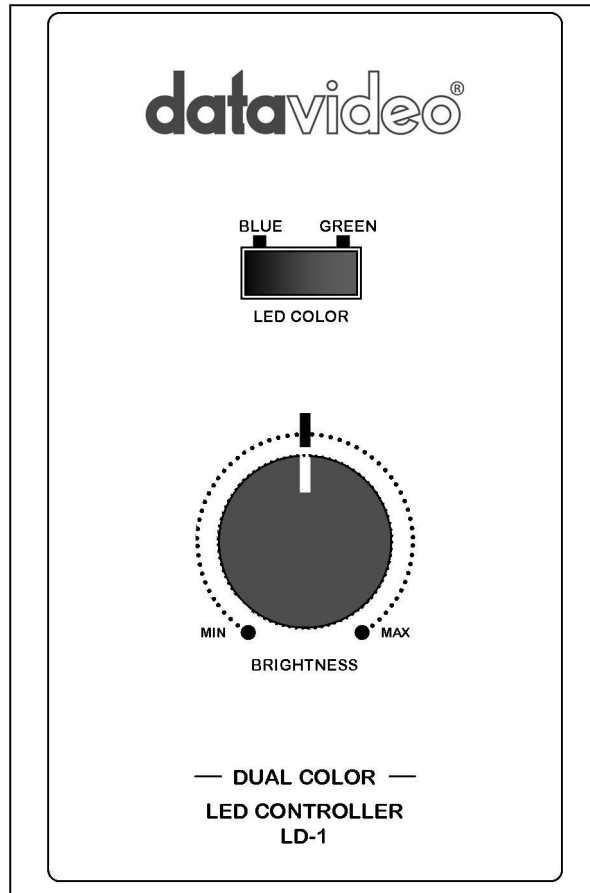

LED Colour Switch - This switch manually sets the colour of the bi-colour light ring to Green or Blue.

N.B. This switch is only operational if the **Control Mode Switch** is set to **Local** and the **Remote Control Mode Switch** is set to **Int**.

Brightness Control Knob - This knob controls the intensity of the LED light ring. It is important for the light ring to be sufficiently bright to give a crisp chroma key effect without be over bright causing a colour cast and making it uncomfortable for the talent to look at. Vary the intensity until the desired effect is obtained.

Front Panel

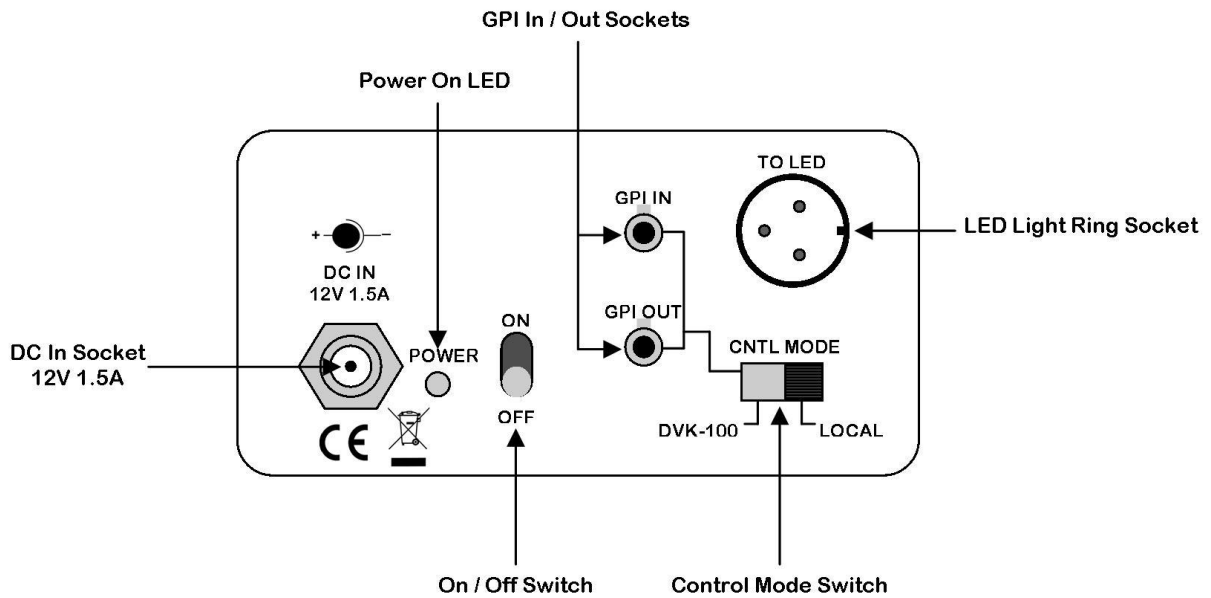

DC In Socket - Connect the 12V 1.5A Power Supply to this socket. The connection can be secured by screwing the outer collar on the plug into place.

On / Off Switch - Switches the power to the light ring On or Off.

Control Mode Switch - Switches the control mode of the LD-1 to local control or remote control from the Datavideo DVK-100 Mk II. **See *operating with the DVK-100 Mk II***

LED Light Ring Socket - Connect the Datavideo Dual Colour Light Ring to this socket.

GPI In / Out Sockets - The GPI In and Out Sockets can be connected to the Datavideo DVK-100 Mk II to enable switching control of the LD-1 from the DVK-100, or of the DVK-100 from the LD-1. **See *operating with the DVK-100 Mk II***

Power On LED - Indicates the LD-1 is powered up and switched on.

Rear Panel

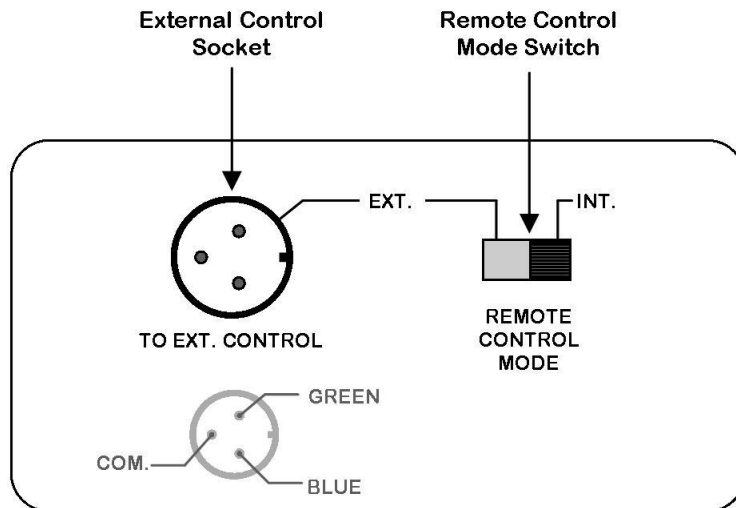

External Control Socket - Allows the LD-1 to be controlled from an external switch or other type of controller. *See External Control.*

Remote Control Mode Switch - Switches the LD-1 between Local and Remote Control. *See External Control*

Operating With The Datavideo DVK-100 Mk II

The LD-1 can be used to control the switching of the DVK-100 Mk II, alternatively the DVK-100 Mk II can be used to control the switching of the LD-1.

N.B. If you own a DVK-100 and you are unsure whether it is Mk I or Mk II please check the serial no. - Mk II will be 00097180 or higher. If your DVK-100 is Mk I please contact your local Datavideo Office for details of how to get it upgraded.

Connect the two GPI cables between the TD-1 and the DVK-100, the GPI Out from the TD-1 goes to GPI In on the DVK-100 and Vice Versa.

Using the 20cm S-Video cable supplied with the LD-1, connect the CAM 1 (Green) S-Video Out to the CAM-2 (Blue) S-Video In. *We are assuming that you are using an S-Video connection from your camera to the DVK-100.*

To control the DVK-100 from the LD-1 set the CNTRL MODE switch to Local, when you switch the LD-1 from Green to Blue the DVK-100 will automatically switch from CAM-1 to CAM-2.

To control the LD-1 from the DVK-100 set the CNTRL MODE switch to DVK-100, when you switch the DVK-100 from CAM-1 to CAM-2 the LD-1 will automatically switch from Green to Blue - *The Green / Blue switch on the LD-1 will become inactive in this mode.*

Set the DVK-100 up for Green Chroma Keying on CAM-1 and Blue Chroma Keying on CAM-2.

LD-1 and DVK-100

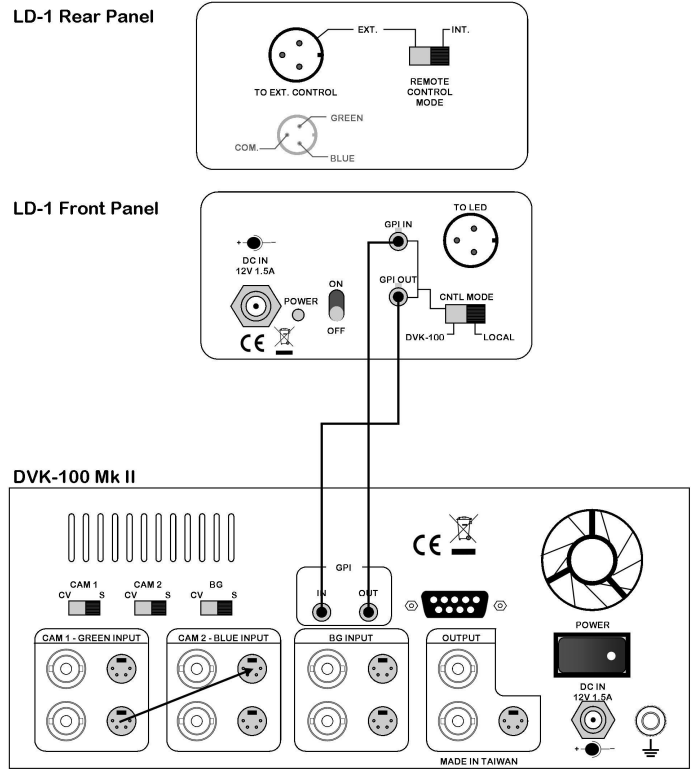

External Control

The LD-1 can be controlled from GPI Triggers or simple switches. The external controls can switch the LD-1 from Green to Blue, as well as switching the DVK-100 from CAM-1 to CAM-2. It is also possible to switch the LD-1 On / Off remotely.



There is a 2m remote control cable supplied with the LD-1, this can be used in integrate into your chosen application. The diagram on the right above uses the colour coding of the supplied cable.

To use external control set the REMOTE CONTROL MODE switch to EXT and the CNTL MODE switch to Local. The external control will switch the colour of the light ring from Green to Blue and the DVK-100 from CAM-1 to CAM-2.

Light Ring

The Light Ring is supplied with a mounting ring with a 72mm thread. For camcorders with different thread sizes such as 58mm, 62mm, 67mm you will require a stepping ring. If your camcorder is 82mm an additional 82mm mounting ring is available, this ring has a larger internal diameter which will prevent any vignetting in the corners of the image when the camcorder is zoomed to wide angle.

Please contact your supplier, or your local Datavideo Office for details.

To mount the Light Ring onto your camcorder first screw on the mounting ring, using a stepping ring if necessary.

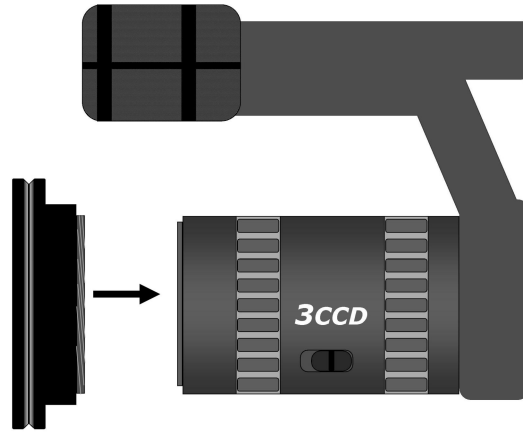

Align the light ring with the mounting ring and ensure the four grub screws are not screwed in too far to impede the fitment.

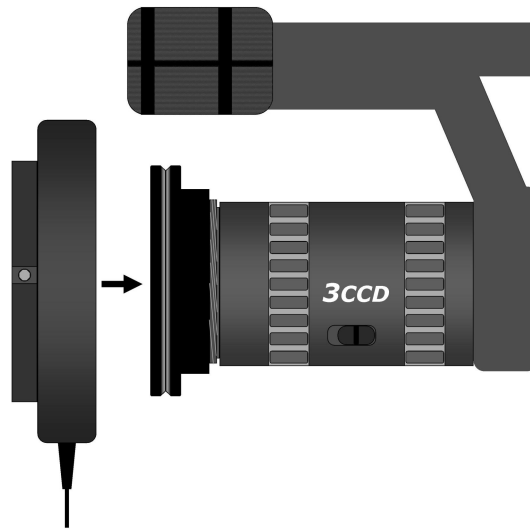

Push the light ring over the mounting plate so that the grub screws are aligned with the groove at the front of the mounting ring.

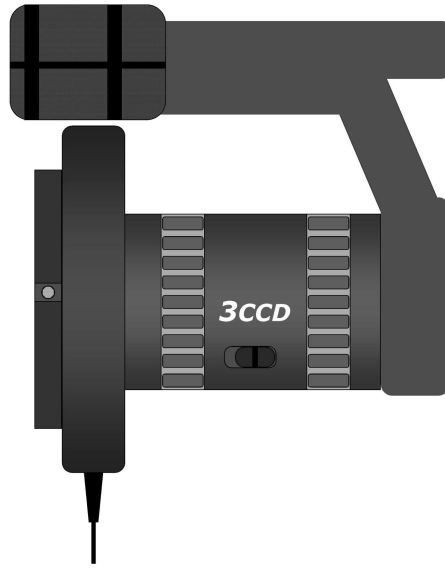

Secure the Light Ring in place by tightening the four grub screws with the supplied Allen Key

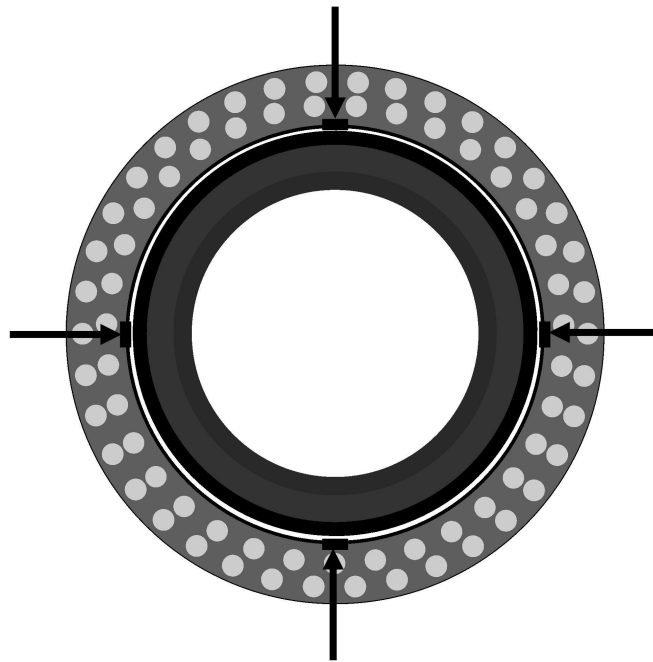

Useful Accessories

Datavideo DVK-100 Dual Channel Chroma Keyer



The DVK-100 is a stand alone, dual channel, chroma keyer that allows automated operation from the LD-1. The two camera inputs can be set up with Green on CAM 1 and Blue on CAM 2. The DVK-100 is easy to operate and quick to set up, ideal for mobile applications, education, small studios etc.

Datavideo RF-3025 Retro Reflective Cloth



RF-3025 is a 3m x 2.5m Retro Reflective Backcloth.

The special material reflects light directly back towards the camera, so although it appears grey to the naked eye it creates a perfect Green / Blue background when used in conjunction with the Datavideo Dual Colour Light Ring.

Specifications

Light Ring

Outer Diameter	13.2 cm
Inner Diameter	10 cm (excluding any adapter rings)
Weight	154g

LD-1

Power Requirement	12V 1.5A (2.1mm In-Line Jack centre positive)
Dimensions (Incl. Mounting Plate)	12.5 x 7.3 x 6 cm L x W x D
Weight	324g

All the trademarks are the properties of their respective owners.
Datavideo Technologies Co., Ltd. All rights reserved 2007.

Specifications are subject to change without notice

Service and Support

It is our goal to make your products ownership a satisfying experience. Our supporting staff is available to assist you in setting up and operating your system. Please refer to our web site www.datavideo-tek.com for answers to common questions, support requests or contact your local office below.

Datavideo Corporation (USA)

12300-U East Washington Blvd., Whittier, CA 90606 USA

Tel: +1 562 696 2324

contactus@datavideo.us

www.datavideo.us

Datavideo Technologies Europe BV

Floridadreef 106, 3565 AM Utrecht, The Netherlands

Tel: +31 30 261 9656

info@datavideo.nl

www.datavideo.info

Datavideo UK Limited

Unit 2 Waterside Business Park, Hadfield, Glossop, Derbyshire SK13 1BE UK

Tel: +44 1457 851000

sales@datavideo.co.uk

www.datavideo.info

Datavideo Technologies Co., Ltd.

10F, 176 Jian-Yi Rd, Chung Ho City, Taipei Hsien, Taiwan 235

Tel: +886 2 8227 2888

service@datavideo.com.tw

www.datavideo.com.tw

Datavideo Technologies China Co.

2F-D, 2 Lane 777, West Guangzhong Rd, Zhabei District, Shanghai, China

Tel: +86 21 5603 6599

service@datavideo.cn

www.datavideo.cn

Datavideo Technologies (S) PTE Ltd.

No. 100, Lorong 23 Geylang, #01-03 D'Centennial Bldg, Singapore 388398

Tel: +65 6749 6866

info@datavideo.sg

www.datavideo.info

Datavideo Hong Kong Limited

G/F., 26 Cross Lane, Wanchai, HK

Tel: +852 2833 1981

info@datavideohk.com

www.datavideohk.com