



Specifications: HP129i

System Type	12" 2-way high-power ported (150 Watt transformer for 70.0/100/25 Volt or 8 ohm direct)
Impedance (nominal) ¹	8 ohms
Sensitivity dB @ 2.83V/1M	97.0 dB
Sensitivity dB @ 1W/1M ²	97.0 dB
Frequency Response (-3 dB) ³	118 Hz - 16 kHz
Frequency Response (-10 dB) ³	73 Hz - 19 kHz
Max. Program Power ⁴	300 w
Max. Continuous Power RMS ⁵	150 w
Max. Power SPL @ 1 M ⁶	119.0 dB
Coverage Angle (-6 dB @ 2 kHz)	80°
Coverage Angle (-6 dB @ 10 kHz)	90°
Coverage Angle (Avg. 2 - 10 kHz)	95°
Directivity Factor (Q)	6.1 (Avg. 100 Hz - 10 kHz) 10 (2 kHz)
Directivity Index (DI)	6.6 dB (Avg. 100 Hz - 10 kHz) ; 10 dB (2 kHz)
Tap Selector	5-Position rotary switch with 8 ohm direct
Transducer - Low Frequency Driver	305 mm (12 in) Treated fiber cone, treated cloth surround
Transducer - High Frequency Driver	1 x 35 mm (1.375 in) Mylar compression driver with waveguide
Low Frequency Voice Coil	50.8 mm / 2.00 in
Crossover Frequency	2.2 kHz
Network Type: Low Pass	24 dB per octave, 4th order
Network Type: High Pass	24 dB per octave, 4th order
Enclosure Material	Injection molded ABS baffle, glass fiber reinforced
Grille	Iridite-plated steel with powder-coat finish
Inputs	4 Pin, 5 mm Euroblock for individual or daisy chain connection
Colors	Black or white
Height	17.8 in / 452.1 mm
Diameter	18.0 in / 457.2 mm
Weight	28.0 lb / 12.7 kg
Shipping Weight	35.0 lb / 15.9 kg
Accessories	
Included	Hanging hardware, Euroblock connector & terminal weather boot
Optional	Surface mount bracket (AC-HP-SM129)
Packaging	1 per box
Regulatory - UL	Pending

¹ Impedance listed per IEC 60268-5

² 1w1m sensitivity determined using nominal impedance

³ Frequency response measured in half or full space as dictated by speaker mounting configuration

⁴ Max program power is 3 dB above max continuous power

⁵ Continuous power rating, EIA-426-B test

⁶ Max output based on max continuous power

⁷ Max useable SPL based on testing by NWA Labs

Transformer Taps

70.7 V Output		100 V Output		20 V Output	
150 w	119.0 dB	150 w	119.0 dB	19 w	110.0 dB
75 w	116.0 dB	75 w	116.0 dB	9.5 w	107.0 dB
38 w	113.0 dB	38 w	113.0 dB	4.8 w	104.0 dB
19 w	110.0 dB			2.4 w	101.0 dB

Key Features

- High-SPL, high-efficiency system for the sound reinforcement and PA markets.
- BroadBeamHP® coverage pattern providing smooth response and maximum SPL across the audio spectrum.
- One 305 mm (12 in) treated fiber cone with a treated cloth surround and one 35 mm (1.375 in) Mylar compression driver with waveguide.
- Reduced amplification costs and maximum efficiency (97 dB sensitivity), with 8 Ohm impedance.
- Weatherized components for indoor/outdoor applications and a ported enclosure for added bass response (down to 73 Hz, -10 dB).
- Easy-access 5-position tap switch for 25/70.7/100 Volt and 8 Ohm settings allows for easy ordering, stocking and installation.
- UL 1480 pending.
- Included accessories: hanging hardware, Euroblock connector, terminal weather boot.
- Optional accessories: surface-mount bracket (AC-HP-SM129).
- High quality black or white painted finish. Custom colors available.

Description

The HP129i is a 12" coaxial 2-way hanging speaker with a surface-mount option and a proprietary BroadBeamHP® waveguide. Engineered to deliver true high-SPL performance, the HP129i incorporates a 12" treated fiber cone and one 35 mm (1.38 in) Mylar compression driver with a professional-grade electro-acoustic subassembly. The result is a pendent-mount speaker with maximum efficiency (97 dB 1W/1M) and an extended frequency response from 73 Hz - 19 kHz (-10 dB). For lasting performance, the enclosure is made from injection-molded, glass-filled ABS.

Mounting hardware is included and features hanging and safety cables, Euroblock connector and terminal weather boot. For easy ordering, stocking and installation, every speaker is equipped with a 5-position tap switch for 25, 70.7 & 100 Volt applications with voice coil/8 Ohm bypass. For surface-mount applications, SoundTube offers a surface mount adaptor (AC-HP-SM129).



Applications

Developed specifically for true PA and sound reinforcement applications including arenas, stadiums, gyms, ice rinks, nightclubs and other open ceiling or outdoor applications where rapid installation, high-SPL and lasting durability are required.

Patented SoundTube Technologies

SoundTube Entertainment and the MSE Audio Group constantly develop new technologies which enhance audio product performance. SoundTube Entertainment innovations are protected by multiple U.S. & international patents, which explicitly cover SoundTube dome, enclosure and dispersion technologies. The MSE Audio Group actively defends its patents in order to protect SoundTube resellers and end-users

Technical Data and Specification Tools

Technical Data

SoundTube Entertainment strives to provide complete and effective technical information and data to dealers, engineers and designers. All data are available from SoundTube Entertainment or at www.soundtube.com and includes **EASE™** Data – 3-D polar plots and **SoundTubeSPEC™** – Proprietary SoundTube speaker placement software.

Acquisition & Verification

All data for SoundTube speakers is independently collected from and verified by NWAALabs (www.nwaalabs.com) using their proprietary MACH testing system. All data are collected and analyzed according to ASTM, ISO and AES standards using EASERA, TEF and MLSSA. Full balloon data including both phase and magnitude is compiled into a variety of formats including EASE 4.x, GLL and CLF.

Architectural Specifications

The loudspeaker shall consist of one 305 mm (12 in) low-frequency transducer and one 35 mm (1.375 in) high-frequency transducer with a frequency dividing network installed in a ported enclosure. The low-frequency voice coil diameter shall be 50.8 mm (2.0 in). The low-frequency transducer shall have treated fiber cone material with a treated cloth surround. The high-frequency transducer shall be constructed of Mylar material.

Performance specifications of a typical production unit shall be as follows: Usable frequency range shall extend from 73 Hz - 19 kHz, -10 dB. The loudspeaker shall be available with selectable 25/70.7/100 Volt and 8 Ohm/voice coil direct tap switch. The frequency dividing network shall have a cross-over frequency of 2.2 kHz. Rated power capacity of the components and network shall be at least 150 Watts contin-

uous RMS and conform to EIA-426-B testing. Maximum continuous output at 1 meter shall be at least 119 dB.

The ported enclosure shall be constructed from injection molded, glass-reinforced ABS with a total volume of 1700 cubic inches. The grille shall be constructed of iridite-plated steel with a powder coat finish and affix to the speaker via friction fit with two blind mounted, radial screws.

The HP129i shall ship complete with mounting hardware including hanging and safety cables, Euroblock connector and terminal weather boot. The HP129i has an optional surface mount bracket (AC-HP-SM129).

The HP129i is factory preset to the 150 Watt setting in the 70.7 Volt operating mode, with a tap switch located on the front baffle of the speaker and is accessible by a removable grille plug. Signal input shall be by 4-pin Euroblock connector.

The system shall be the SoundTube HP129i for both low & high impedance applications.

SoundTube Entertainment

6430 North Business Park Loop
Park City, Utah 84098
Phone 435.647.9555
Fax 435.647.9666
Toll Free 800.647.TUBE
www.soundtube.com

All SoundTube products come with a 5-year limited warranty.

Graphs and Plots

Frequency Response

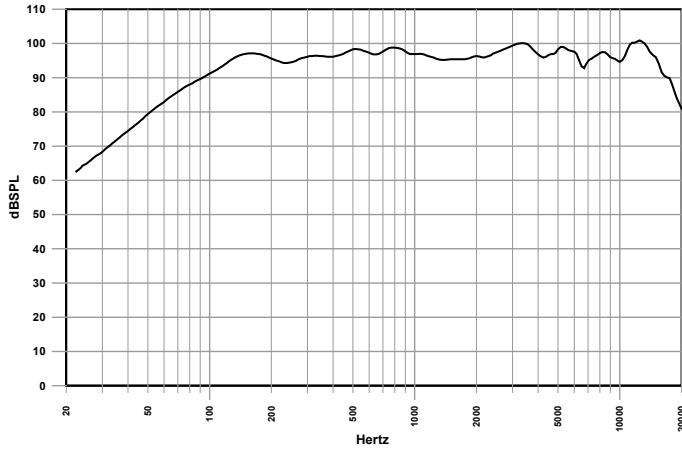

Phase/Impedance Response

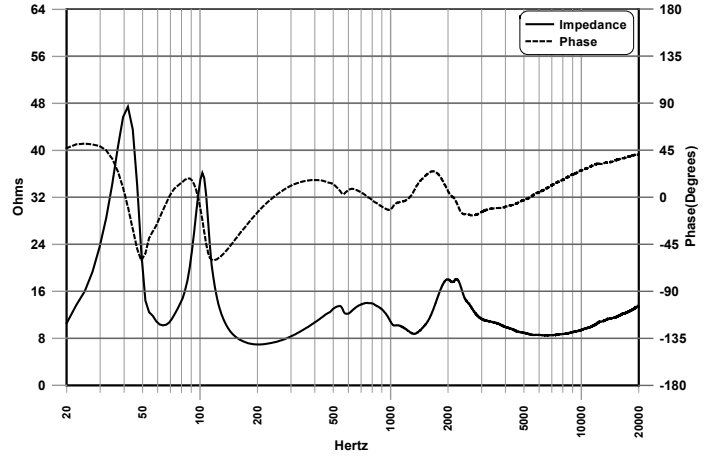

Vertical Beamwidth (-6 dB)

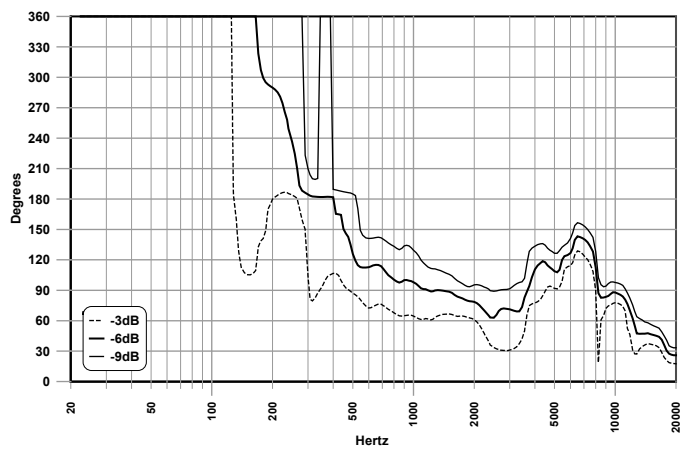

Directivity Index (DI)

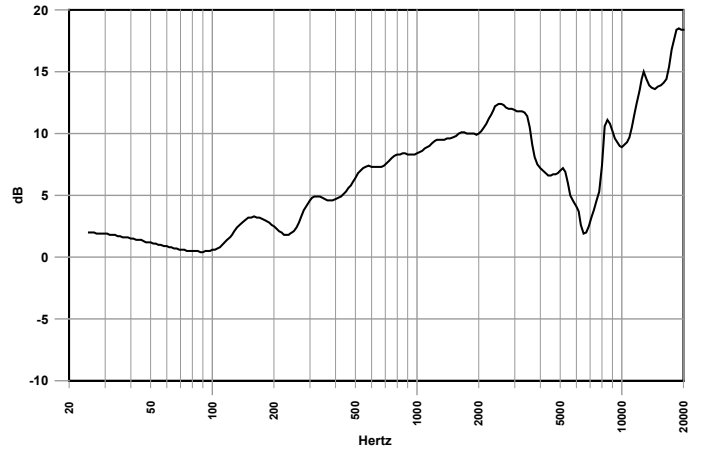

Polar Plots

———— Horizontal
 - - - - - Vertical

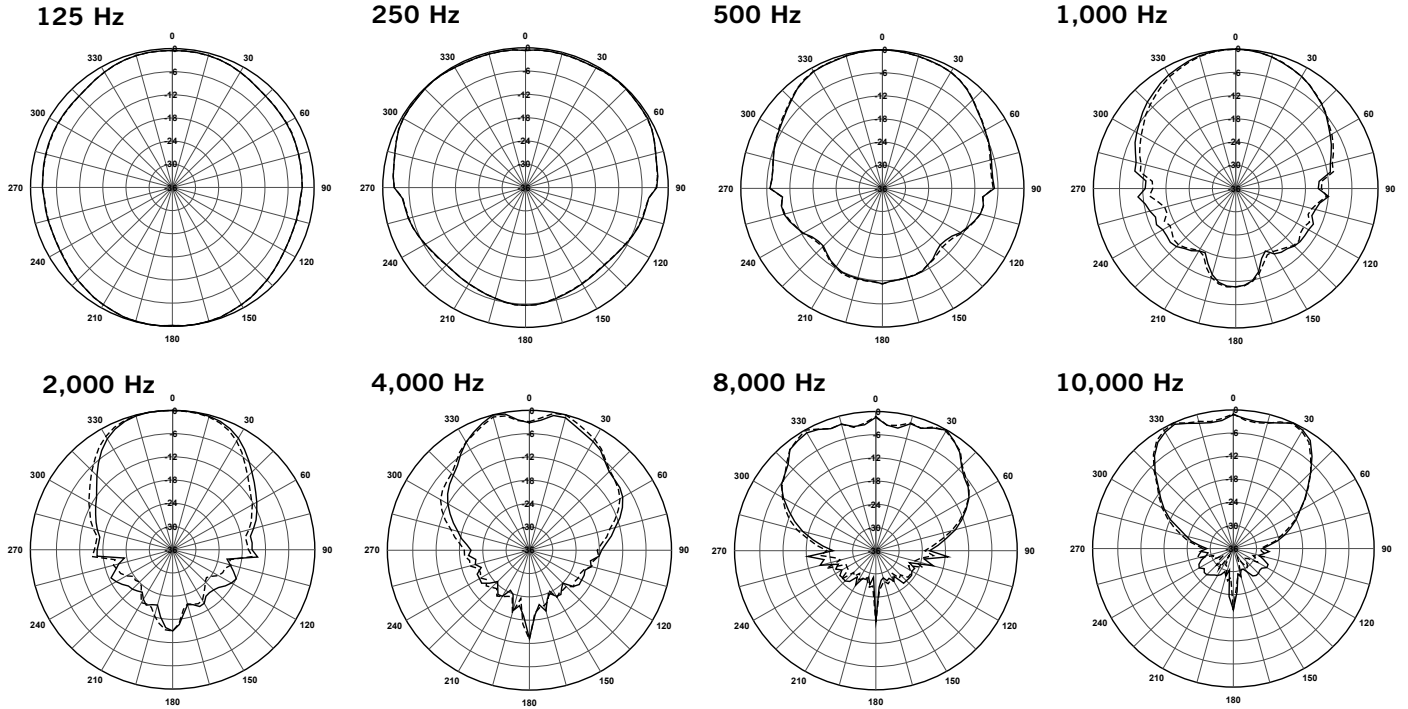

Technical data, EASE™ plots, SoundTubeSPEC™ software & product downloads available at www.soundtube.com

Mechanical Drawings

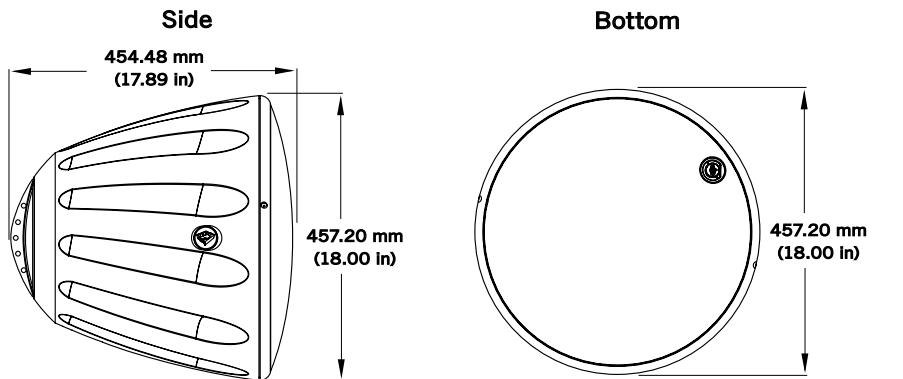

Optional Accessories

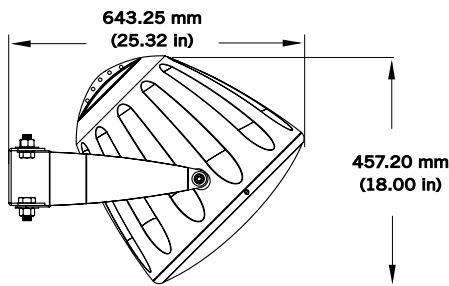

Surface Mount Bracket (AC-HP-SM129)

Included Accessories

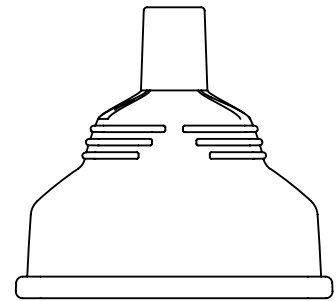

Terminal Weather Boot

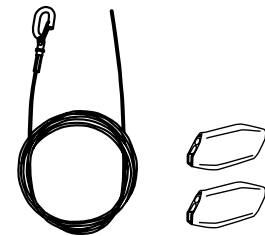

Hanging Hardware

SoundTube Entertainment manufactures a complete line of speakers for:
Open-Ceiling • In-Ceiling • Surface-Mount • Outdoor • Sound-Focusing

All SoundTube products are designed and engineered in the USA.