

## DJ Mixers

# NOX1010/ NOX606/NOX404 NOX303/NOX202

**Premium DJ Mixers with  
infinium "Contact-Free" VCA  
Crossfader, Beat-Syncable FX and  
USB Audio Interface**

**NOX202: Premium 2-Channel DJ  
Mixer with infinium "Contact-Free"  
VCA Crossfader, Beat-Syncable FX and  
USB Audio Interface**

- Premium 2-channel battle DJ mixer for the most demanding turntablist, remixer and digital DJ
- Beat-syncable FX section with 2 parameter controls assignable to Mic, 1, 2 or Master
- Awesome 3-band EQ with full-kill filters plus 6-segment level meters with peak hold function per channel
- Premium phono and XENYX mic preamps for superior detail and ultimate punch
- 2 Line inputs with USB connectivity, 2 Phono/Line and 1 Mic input
- VCA-controlled faders for utmost reliability and noise-free performance
- Sophisticated headphone monitoring and cueing section
- Extensive Master and Record outputs

**NOX303: Premium 3-Channel DJ Mixer  
with infinium "Contact-Free" VCA  
Crossfader, Beat-Syncable FX and USB  
Audio Interface**

- Premium 3-channel club DJ mixer for the most demanding turntablist, remixer and digital DJ
- Beat-syncable FX section with 2 parameter controls assignable to Mic, 1, 2, 3, CFA, CFB or Master

behringer.com



BEHRINGER NOX Series DJ Mixers are built to connect directly to your computer and take your music straight into the digital realm. In an instant, these mixers allow you to record and play any digital music file with your PC or Mac computer without the need for any special drivers! Plus we've included the infinium "contact-free" VCA Crossfader, our legendary XENYX mic and premium-grade phono preamps, and beat-syncable FX for years of flawless performance.

### No Media Boundaries

Like the DJ mixers that started it all, the NOX Series offer RCA inputs for your turntables, tape decks and CD players. They also feature mic inputs with our exceptional XENYX mic preamps for announcements, an impromptu rap, or any other vocal nuance. But unlike the DJ mixers of yesteryear, NOX Series mixers

include USB connectivity so you can access your MP3 library or digitize your own creative mix, directly via your computer. If it can be clicked, spun or spoken, the NOX Series can mix it!

### Calling All DJs

Whether you're throwing multiple elements into the mix, or just keeping it simple, there's a USB-ready NOX Series mixer that's ideal for you. The NOX606 packs a whopping 6 channels, the NOX1010 has five, the NOX303 has three, and the NOX202 and NOX404 each have two channels. All NOX Series models feature super-smooth channel faders and the infinium "contact-free" VCA-controlled crossfader for the utmost in reliability and smooth audio performance. The user-adjustable crossfader curves let you quickly adapt to various mixing styles.

*Continued on next page*



# NOX1010/NOX606 NOX404/NOX303 NOX202

- Awesome 3-band EQ with switchable full-kill filters plus 8-segment level meters with peak hold function per channel
- Premium phono and XENYX mic preamps for superior detail and ultimate punch
- 3 Line inputs with USB connectivity, 3 Phono/Line and 1 Mic input
- VCA-controlled faders with fader start for utmost reliability and noise-free performance
- Sophisticated headphone monitoring section with tone control of headphone output
- Extensive XLR Master, Record and Booth outputs

## NOX404: Premium 6-Channel DJ Mixer with infinium "Contact-Free" VCA Crossfader, Beat-Syncable FX, VCFs and USB Audio Interface

- Premium 6-channel club DJ mixer for the most demanding turntablist, remixer and digital DJ
- Beat-syncable FX section with 2 parameter controls assignable to Mic, 1, 2, CFA, CFB or Master
- 2 mind-blowing VCFs (Voltage Controlled Filters) can be assigned to any channel or crossfader side
- 2 independent LFOs (Low Frequency Oscillators) for awesome filter modulation
- 6 Line and USB inputs, 4 Phono/Line plus 2 Mic/Line inputs—all channels with Gain control, switchable EQ and level meter

## Beat-syncable FX

A useful and powerful addition to NOX Series mixers is the internal effects engine. This processor offers 12 high-quality digital effects that can be assigned to the microphone, channel 1 or 2, crossfader A or B, or the main mix. Each effect has several parameters that can be adjusted to suit your purpose. In general, the TAP button is used to beat-sync the effect to the tempo of the music by pressing it in rhythm. The INTENSITY fader usually controls the wet/dry mix of the effect (how much is blended with the unaffected signal). The FREQUENCY knob can have various assignments. In beat-sync mode (engaged by tapping the rhythm with the TAP button), it will determine the tempo multiple. It can also adjust the rate on its own, if beat-sync is not engaged or not available.

Here's a brief description of the FX available in every NOX Series mixer:

- **2XCOPY:** Makes a copy of the signal, which is delayed by a defined time.
- **TAPE ECHO:** A simulation of the echo effect that occurs between two tape reels, which has a warm, slightly decayed sound.
- **ECHO:** A more modern delay effect, which is very useful for juggling beats and emphasizing musical phrases.
- **FLANGER:** A flanger is a wave-like effect that modulates the signal.
- **PHASER:** A sweeping phase shifter effect. It is similar to a flanger, except that it is enharmonic, producing a more "swooshing" sound.
- **LP and HP FILTER:** A Low Pass filter cuts out any frequency above its parameter settings. A High Pass filter cuts out frequencies below its parameter settings.
- **AUTO PAN:** Automatically moves the signal from one side of the stereo image to the other.
- **VOCODER:** Creates a robot voice sound straight from the early days of electronic music.

- **REVERB:** This is a classic effect that adds space and air to the sound.
- **REV REVERB:** Reverse reverb.
- **LMT+DIST:** Band-limited distortion creates a tight, compressed and distorted sound to any signal.

## Total Control

The NOX202, NOX303, NOX404 and NOX1010 models provide superb tone control, thanks to a 3-band EQ and full-kill filters, Gain control and precise level meter per channel. Meanwhile, the NOX606 features 4-band channel EQ and level meter for MAIN output, plus a post-fader mono output to drive subwoofers. All NOX Series mixers feature extensive headphone monitoring and cueing options.

## NOX202

If the NOX202 had a middle name it would be "easy." The NOX202's intuitive layout makes it easy to operate right out of the box. Beneath its elegant exterior lies the heart of a 2-channel DJ battle mixer complete with a beat-syncable FX section, 3-band channel EQ and full-kill filters. Premium-grade phono preamps, along with our legendary XENYX mic preamps, ensure the ultimate in signal integrity and punch. And thanks to NOX202's onboard USB audio interface you can add your MP3s to the mix with just the flick of a switch. The NOX202 is a veritable killer in its weight class!

## NOX303

Armed with many of the same features as the NOX202, the NOX303 features an additional input channel and VCA-controlled faders with fader start, which allows you to seamlessly integrate auto-start capable CD players. You get our outstanding phono and XENYX mic preamps, renowned for their superior sonic integrity and wide dynamic range, along with built-in USB connectivity. State-of-the-art, beat-syncable FX processing and balanced XLR Master Outputs round out this mighty middleweight.

*Continued on next page*



# NOX1010/NOX606 NOX404/NOX303 NOX202

- 2 XENYX mic preamps with “corrective” EQs and 4 premium phono preamps for superior detail and ultimate punch
- Powerful “asymmetric” 4-band EQs on all line channels with +6 dB boost to preserve headroom and -26 dB cut for creative mixing
- VCA-controlled faders for utmost reliability and noise-free performance
- 2 stereo Aux sends selectable pre-/post-fader on all channels
- 2 balanced mix XLR outputs with Level control, secondary “music only” outputs for recording plus post fader mono output
- Sophisticated Monitor section includes 2 Headphone outputs, split cue, mix to cue balance and post EQ switch
- Rack mount brackets included for ultimate flexibility

## **NOX606: Premium 6-Channel DJ Mixer with infinium “Contact-Free” VCA Crossfader, Beat-Syncable FX, VCFs and USB Audio Interface**

- Premium 6-channel club DJ mixer for the most demanding turntablist, remixer and digital DJ
- Beat-syncable FX section with 2 parameter controls assignable to Mic, 1, 2, CFA, CFB or Master
- 2 mind-blowing VCFs (Voltage Controlled Filters) can be assigned to any channel or crossfader side
- 2 independent LFOs (Low Frequency Oscillators) for awesome filter modulation

behringer.com

## **NOX404**

Much like an NOX202 on steroids, the 2-channel NOX404 ups the ante with a switchable FX LOOP and adjustable fader curves per channel for the ultimate in control and versatility. Connectivity options include Mic, Line and USB sources, so you can bring all your tunes to the party. And the stereo AUX IN section, complete with LEVEL control, is like getting an extra channel for free! Balanced XLR Outputs and our beat-syncable FX processor make this brawler the logical choice for the on-the-go mix-master.

## **NOX606**

The full-featured NOX606 was designed for the DJ who wants everything right at his/her fingertips. With enough inputs to handle a mic, two turntables, two CD players and a USB device (MP3 player or computer), the NOX606 is ready for anything. In addition to the beat-syncable FX processor (which is fully assignable), two VCFs (Voltage Controlled Filters) and two LFOs (Low Frequency Oscillators) can be assigned to any channel or crossfader side for mind-blowing filter and modulation effects. And if still want more, all channels feature two switchable pre-/post-fader stereo AUX sends, so you add outboard FX for unbridled creativity. Sophisticated cueing and monitoring, 4-band EQs on all line channels, and an amazing array of output options make the NOX606 the heavyweight champion of DJ club mixers. There’s even a “music only” output for a secondary listening zone or for recording your sets without

the microphone!

## **NOX1010**

The 5-channel NOX1010 is ready for your input—literally! With a plethora of connectors, the NOX1010 can manage up to 14 independent signal sources, including everything from line-level to mics to USB devices. Features include a dedicated mic channel with 2-band EQ and TALKOVER function, internal Balanced EQ and TALKOVER function, internal beat-syncable digital FX (with TAP button for manual parameter entry), and VCA-controlled faders with fader start, allowing you to seamlessly integrate auto-start capable CD players. You also get our outstanding phono and XENYX mic preamps, which are renowned for their superior sonic integrity and wide dynamic range. The NOX1010’s enhanced monitoring section features a SPLIT/BLEND button, which allows you to combine cue and program sources or split them into phones left (cue) and phones right (main). Balanced XLR Master, Record and Booth Outputs provide exceptional versatility.

## **Value**

When you hook up a NOX Series DJ mixer with USB connectivity, you’re adding the ultimate modern touches to your rig at a price that will leave you with money left over for lots more tunes. The superior build quality and rugged components used in these mixers mean they will serve you well for years to come. Drop in at your nearest BEHRINGER dealer and find out why so many DJs are making musical magic with BEHRINGER.



# NOX1010/NOX606 NOX404/NOX303 NOX202

- 6 Line and USB inputs, 4 Phono/Line plus 2 Mic/Line inputs—all channels with Gain control, switchable EQ and level meter
- 2 XENYX mic preamps with “corrective” EQs and 4 premium phono preamps for superior detail and ultimate punch
- Powerful “asymmetric” 4-band EQs on all line channels with +6 dB boost to preserve headroom and -26 dB cut for creative mixing
- VCA-controlled faders for utmost reliability and noise-free performance
- 2 stereo Aux sends selectable pre-/post-fader on all channels
- 2 balanced mix XLR outputs with Level control, secondary “music only” outputs for recording plus post fader mono output
- Sophisticated Monitor section includes 2 Headphone outputs, split cue, mix to cue balance and post EQ switch
- Rack mount brackets included for ultimate flexibility

## NOX1010: Premium 5-Channel 19" DJ Mixer with infinity “Contact-Free” VCA Crossfader, Beat-Syncable FX and USB/Audio Interface

- Premium 5-channel club DJ mixer for the most demanding turntablist, remixer and digital DJ
- Beat-syncable FX section with 2 parameter controls assignable to Mic, 1, 2, CFA, CFB or Master
- Awesome 3-band EQ with full-kill filters plus 8-element level meters with peak hold function per channel

## NOX202 Top Panel

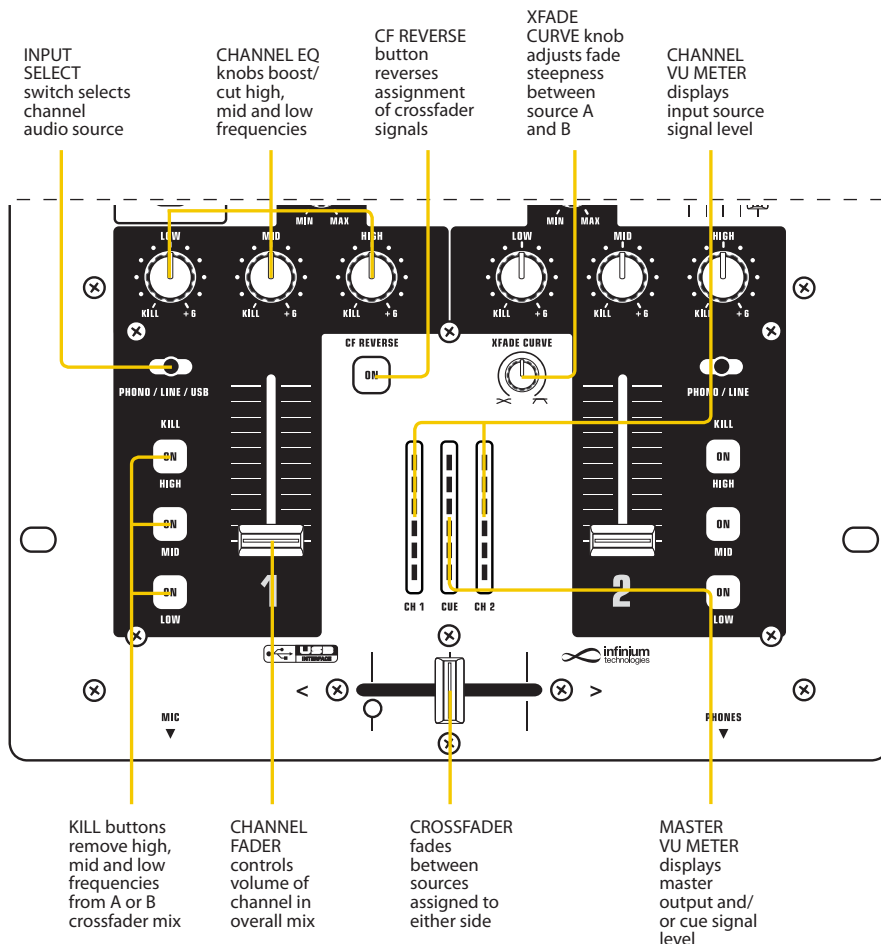
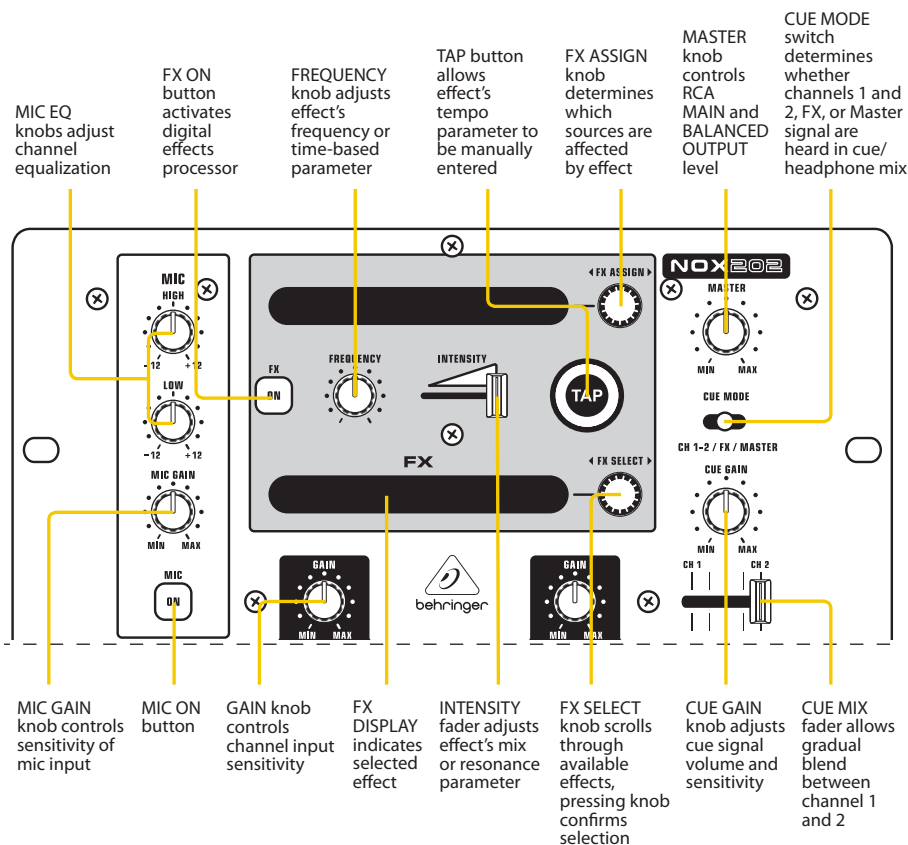

# NOX1010/NOX606 NOX404/NOX303 NOX202

- Premium phono and XENYX mic preamps for superior detail and ultimate punch
- 5 dual line and USB inputs, 3 phono/line plus 2 mic/line inputs
- VCA-controlled faders with selectable fader start for utmost reliability and noise-free performance
- Sophisticated headphone monitoring and cueing section with split cue function
- Extensive XLR Master, Record and Booth outputs

## Common Features:

- 45-mm infinium "Contact-Free" optical crossfader with adjustable tension and fader curve for years of use
- Built-in USB interface for recording and playback of any digital music file. Works with your PC or Mac computer—no setup or drivers required
- "Planet Earth" power supply for maximum flexibility (100 - 240 V~), noise-free audio, superior transient response plus low power consumption for energy saving
- High-quality components and exceptionally rugged construction ensure long life
- Conceived and designed by BEHRINGER Germany

## NOX202 Front Panel



## NOX202 Rear Panel

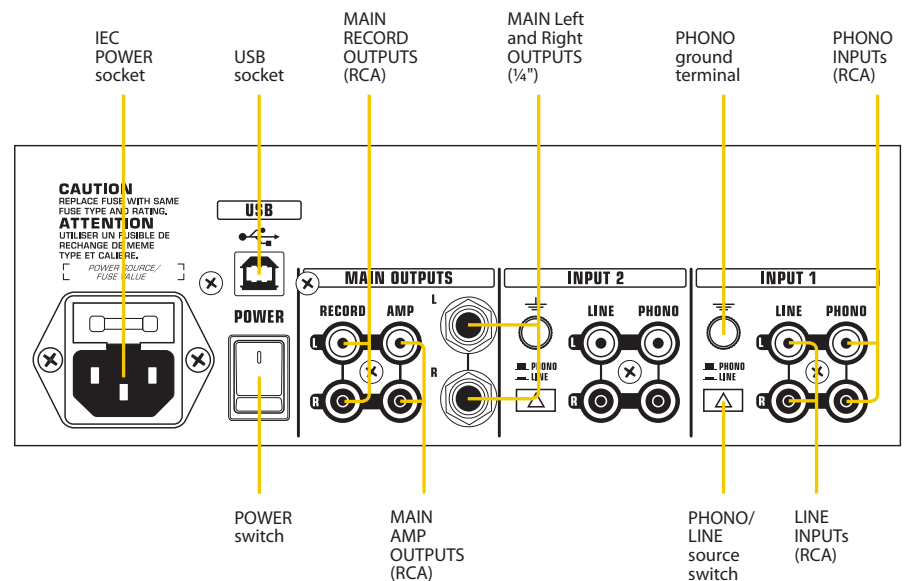

# NOX1010/NOX606 NOX404/NOX303 NOX202

## NOX303 Top Panel

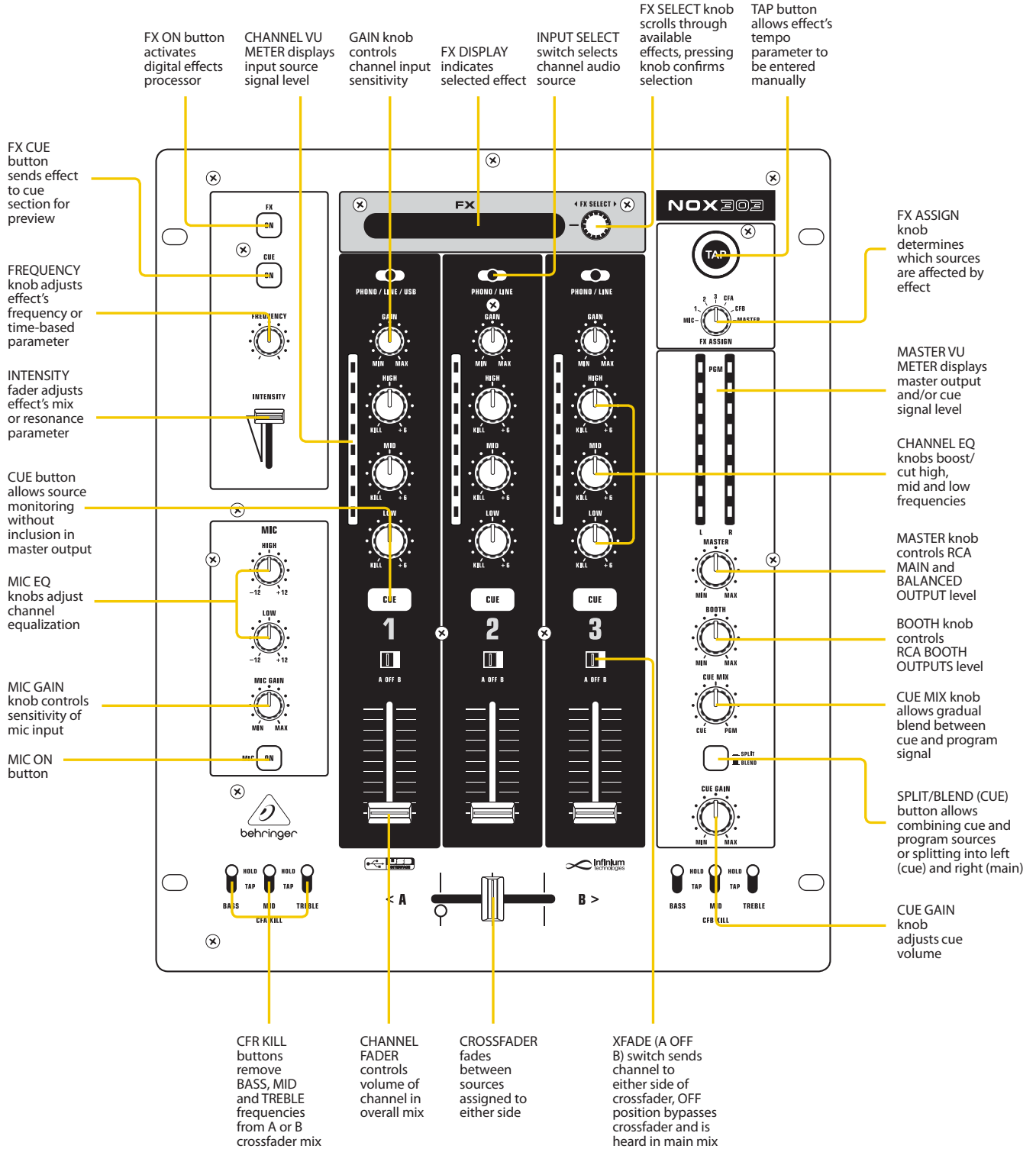



# NOX1010/NOX606 NOX404/NOX303 NOX202

## NOX303 Front Panel

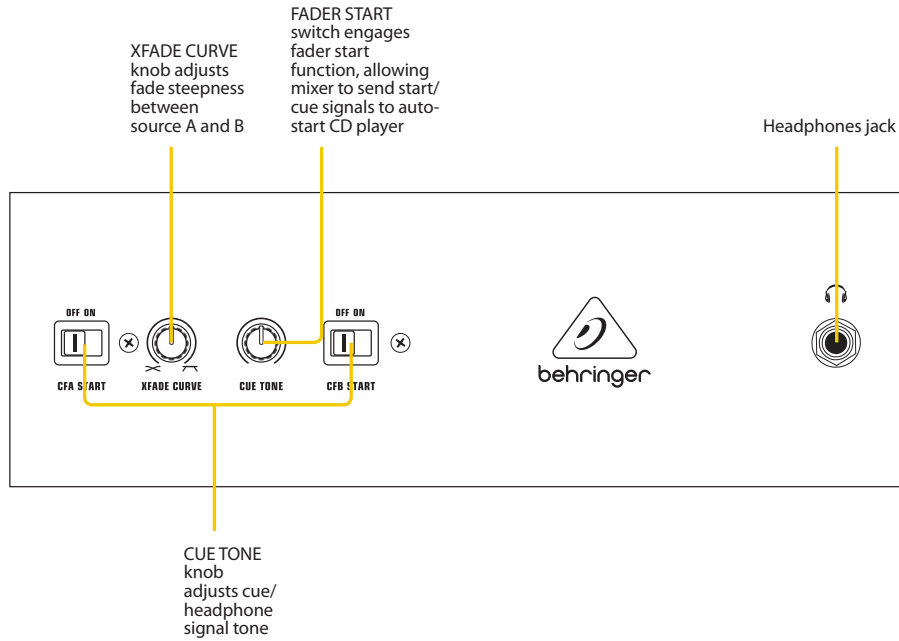

## NOX303 Rear Panel

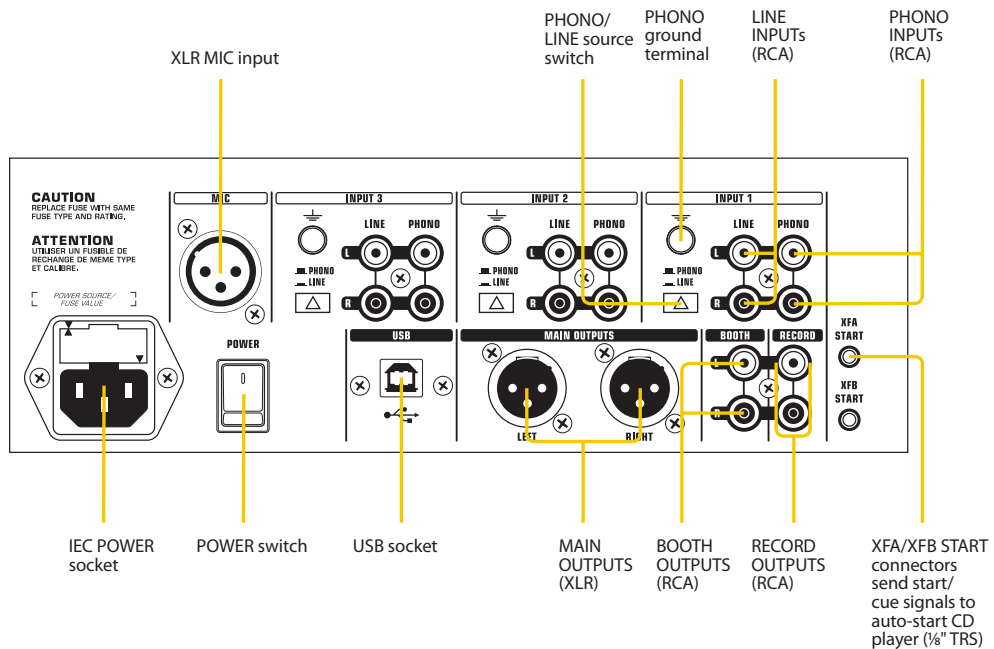

# NOX1010/NOX606 NOX404/NOX303 NOX202

## NOX404 Top Panel

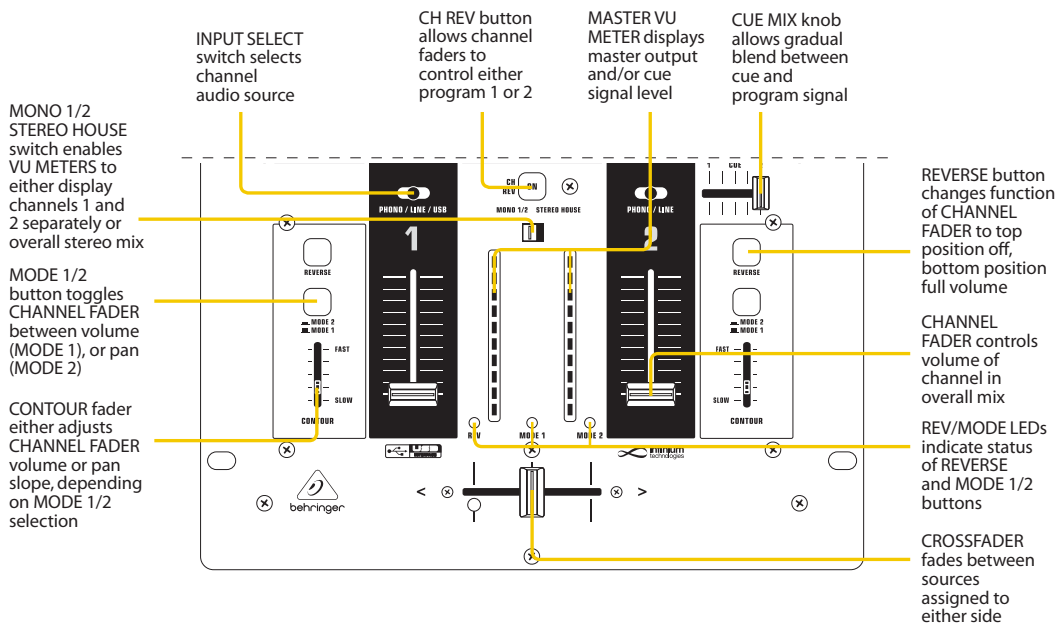
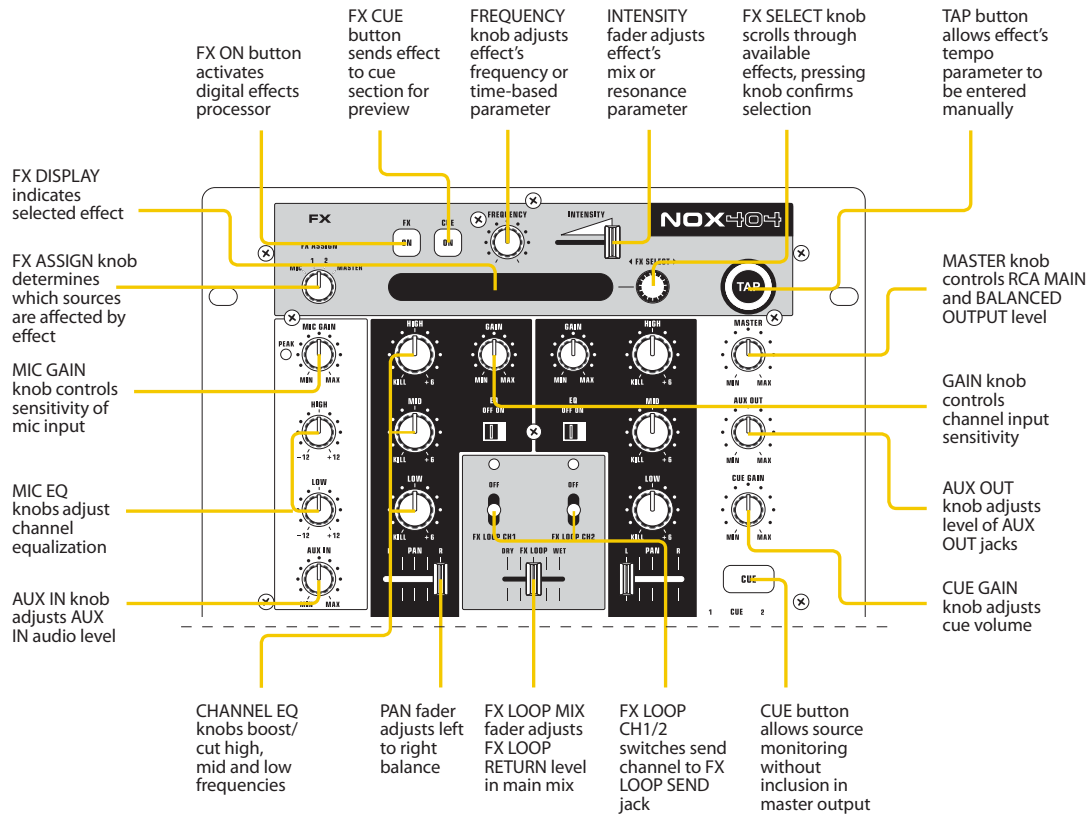



# NOX1010/NOX606 NOX404/NOX303 NOX202

## NOX404 Front Panel

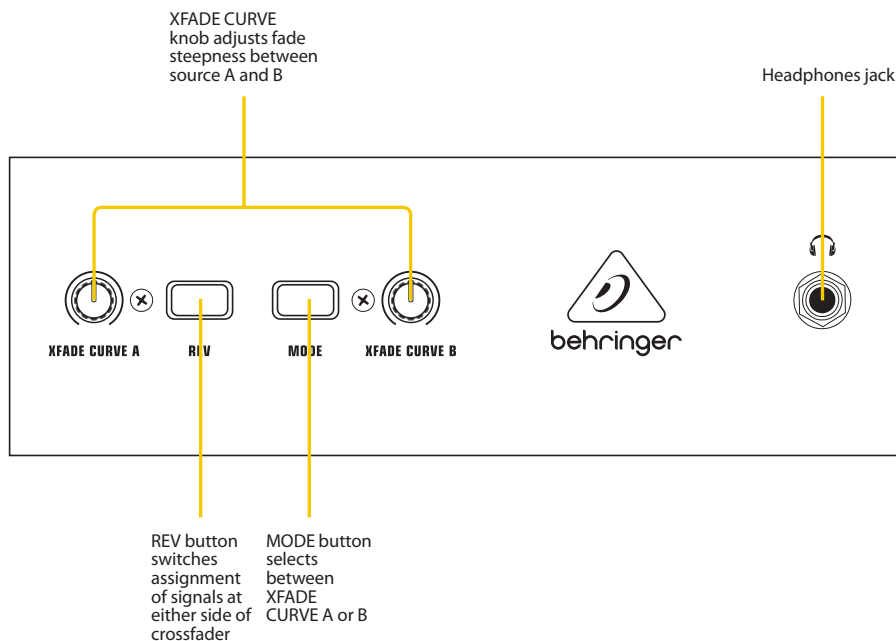

## NOX404 Rear Panel

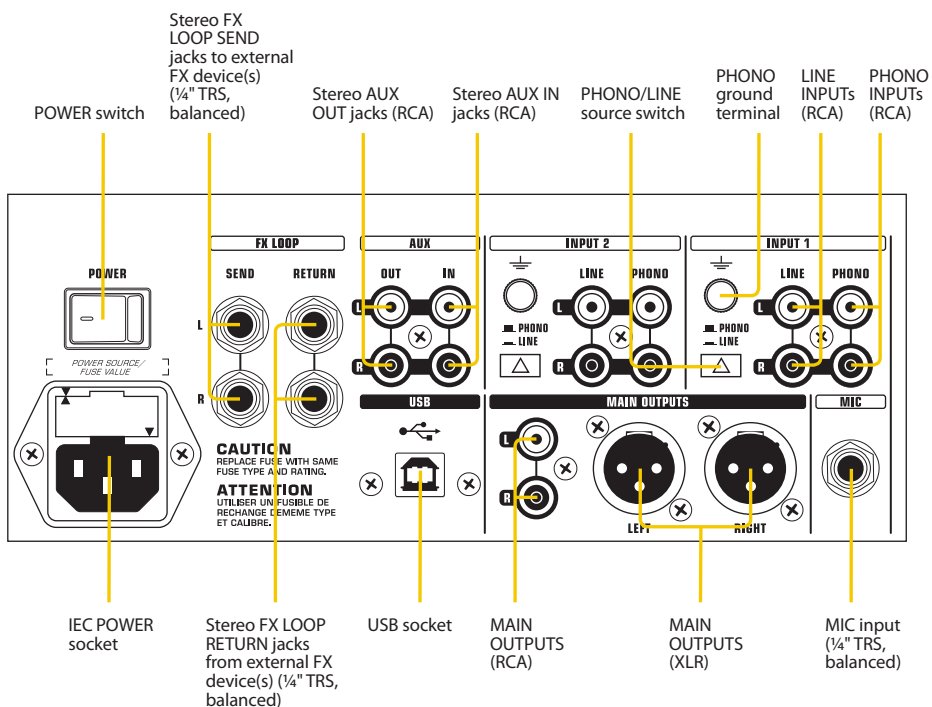

# NOX1010/NOX606 NOX404/NOX303 NOX202

## NOX606 Top Panel

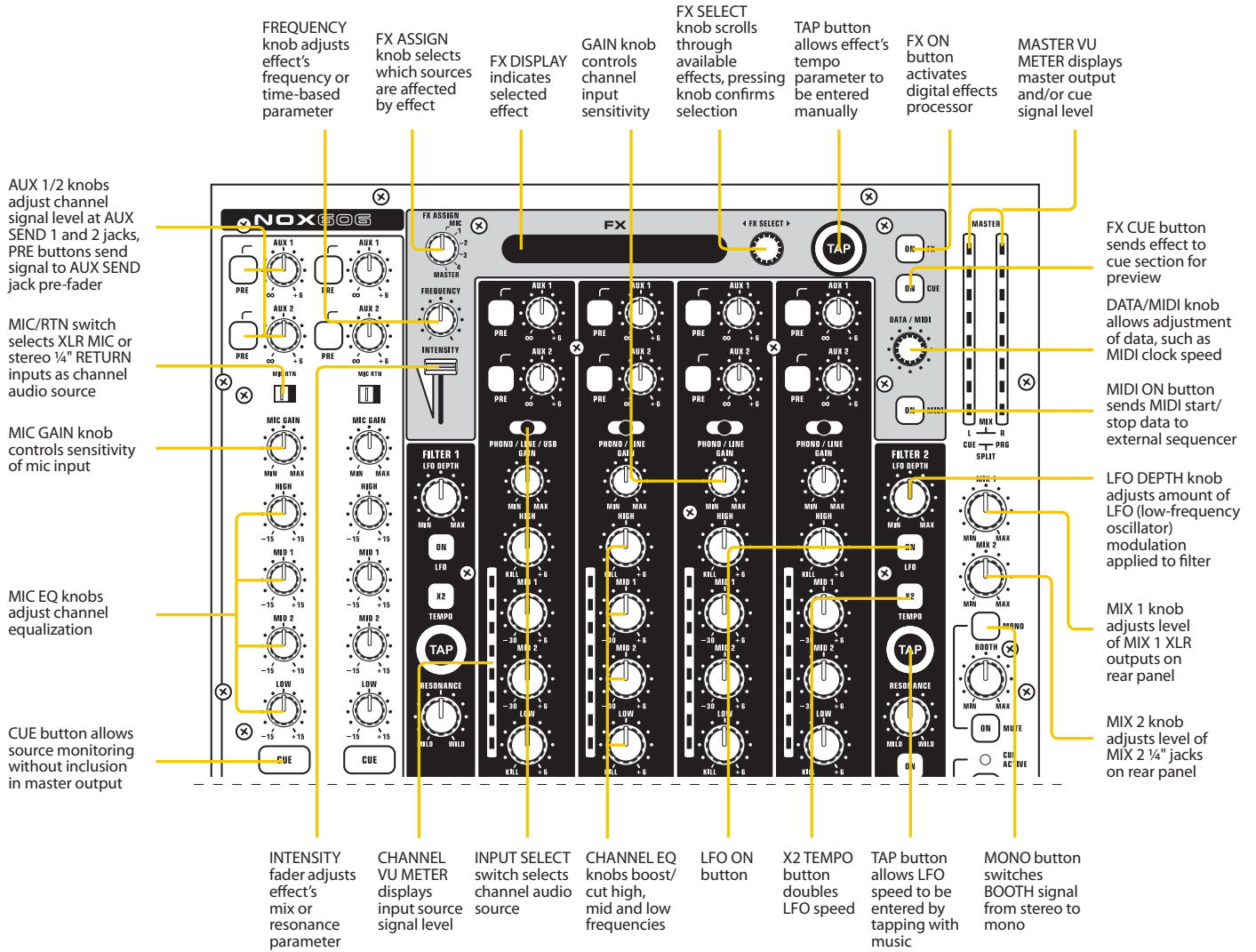

# NOX1010/NOX606 NOX404/NOX303 NOX202

## NOX606 Top Panel

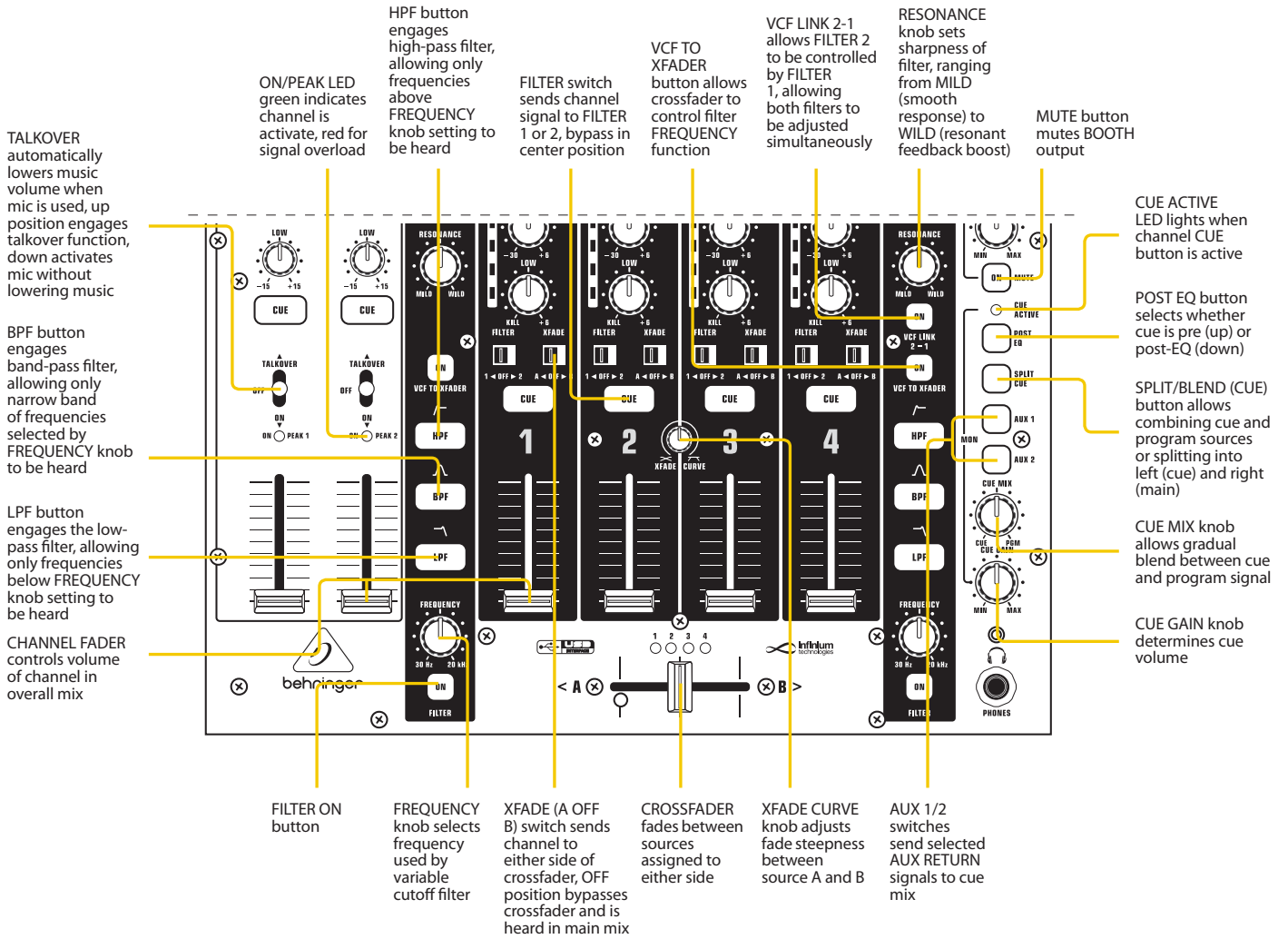

# NOX1010/NOX606 NOX404/NOX303 NOX202

## NOX606 Rear Panel

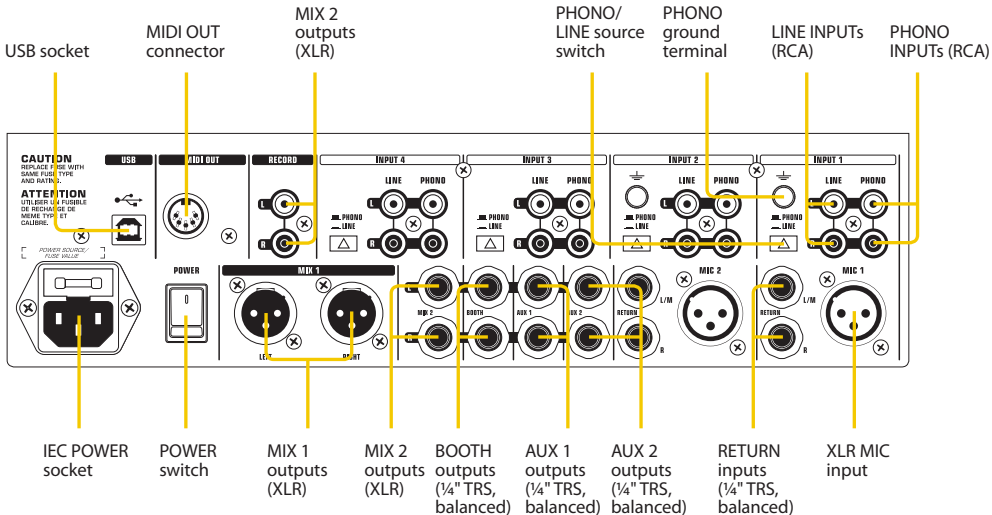



# NOX1010/NOX606 NOX404/NOX303 NOX202

## NOX1010 Top Panel

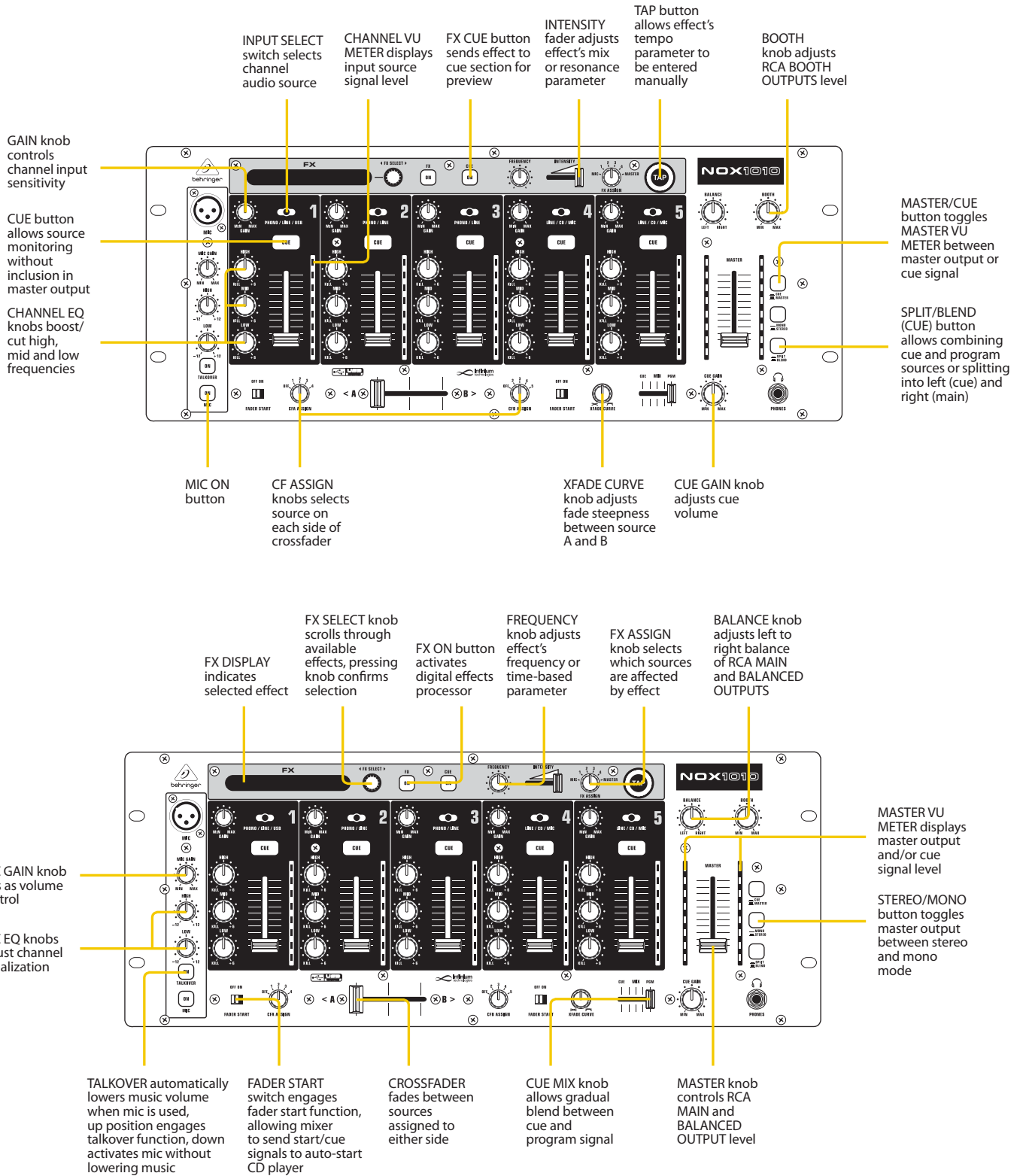

# NOX1010/NOX606 NOX404/NOX303 NOX202

## NOX1010 Rear Panel

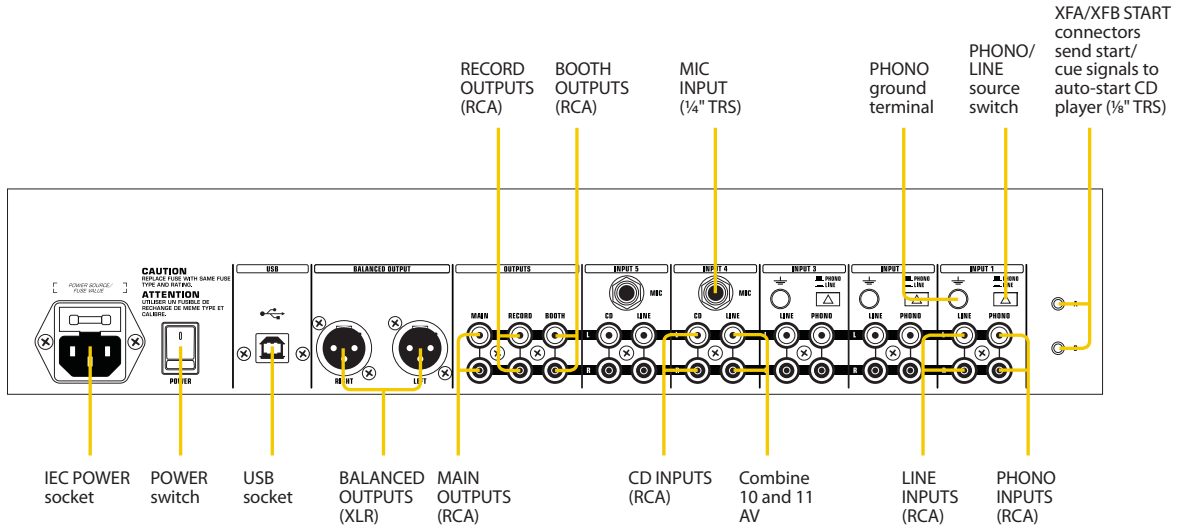

# NOX1010/NOX606 NOX404/NOX303 NOX202

## NOX404 Club sound system

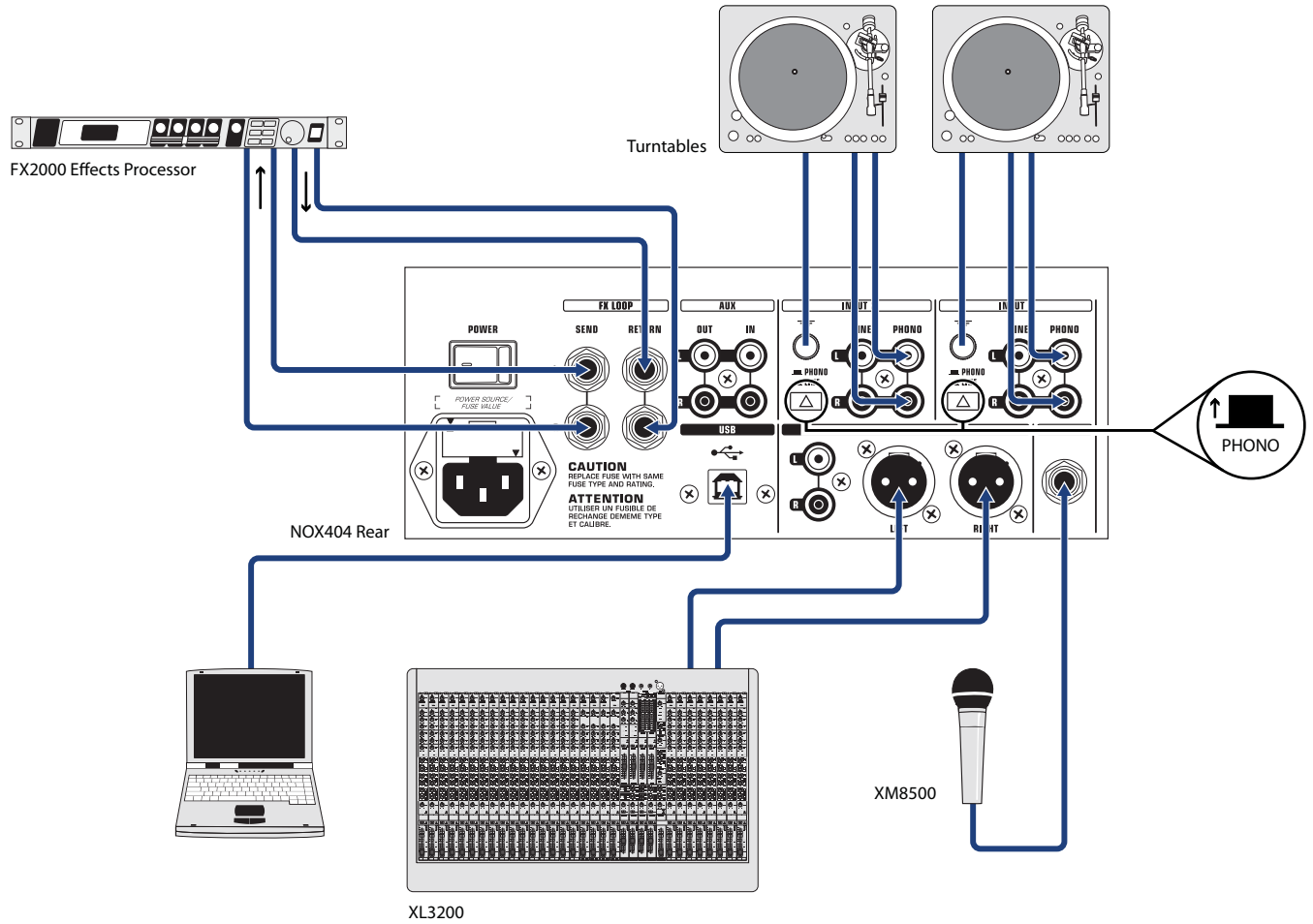





# NOX1010/NOX606 NOX404/NOX303 NOX202

## NOX606 Portable DJ system

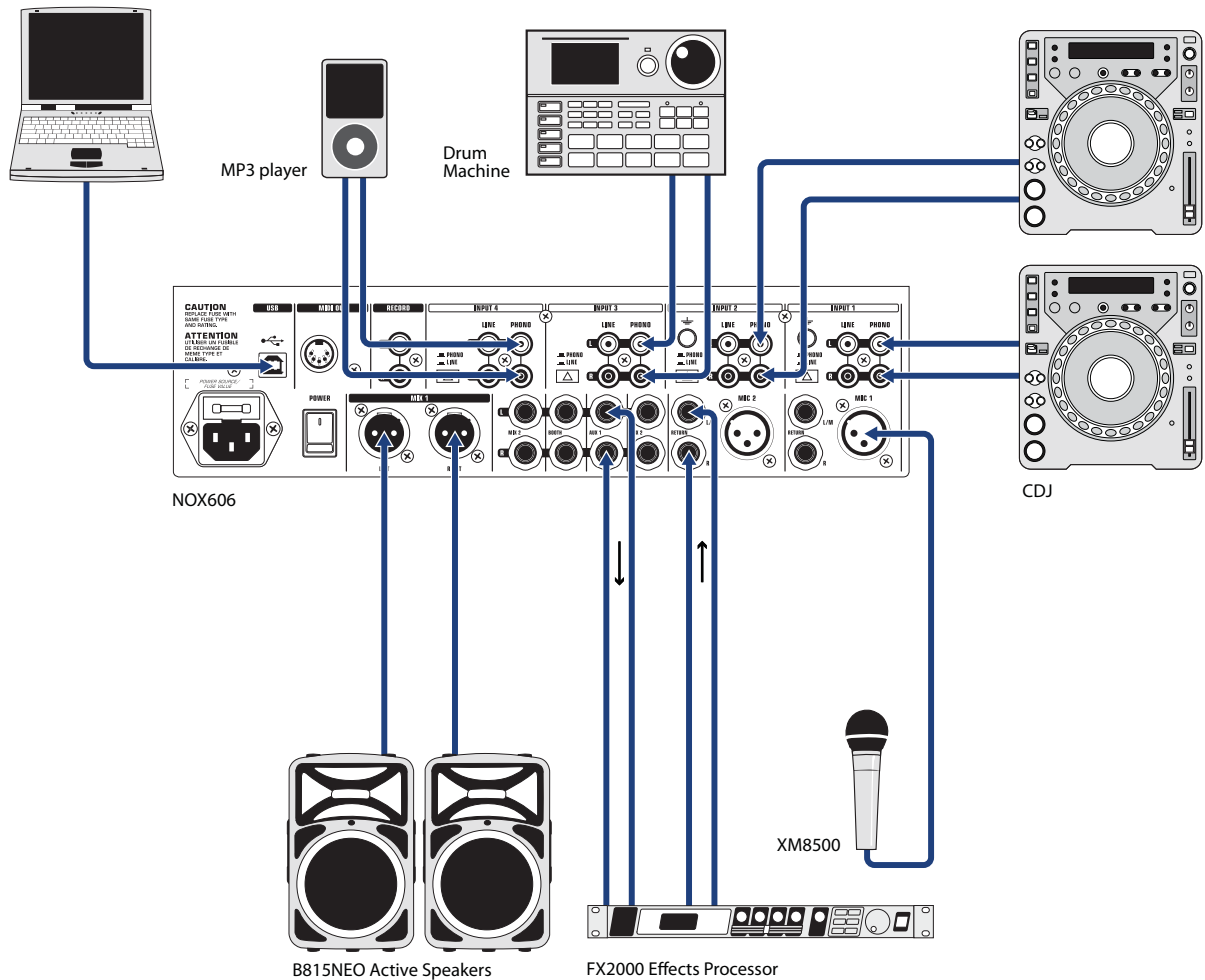
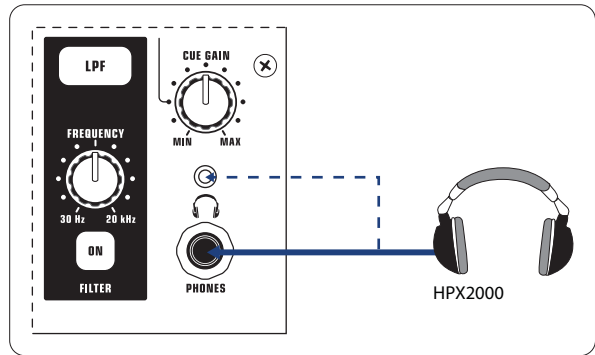

# NOX1010/NOX606 NOX404/NOX303 NOX202

## NOX1010 DJ system

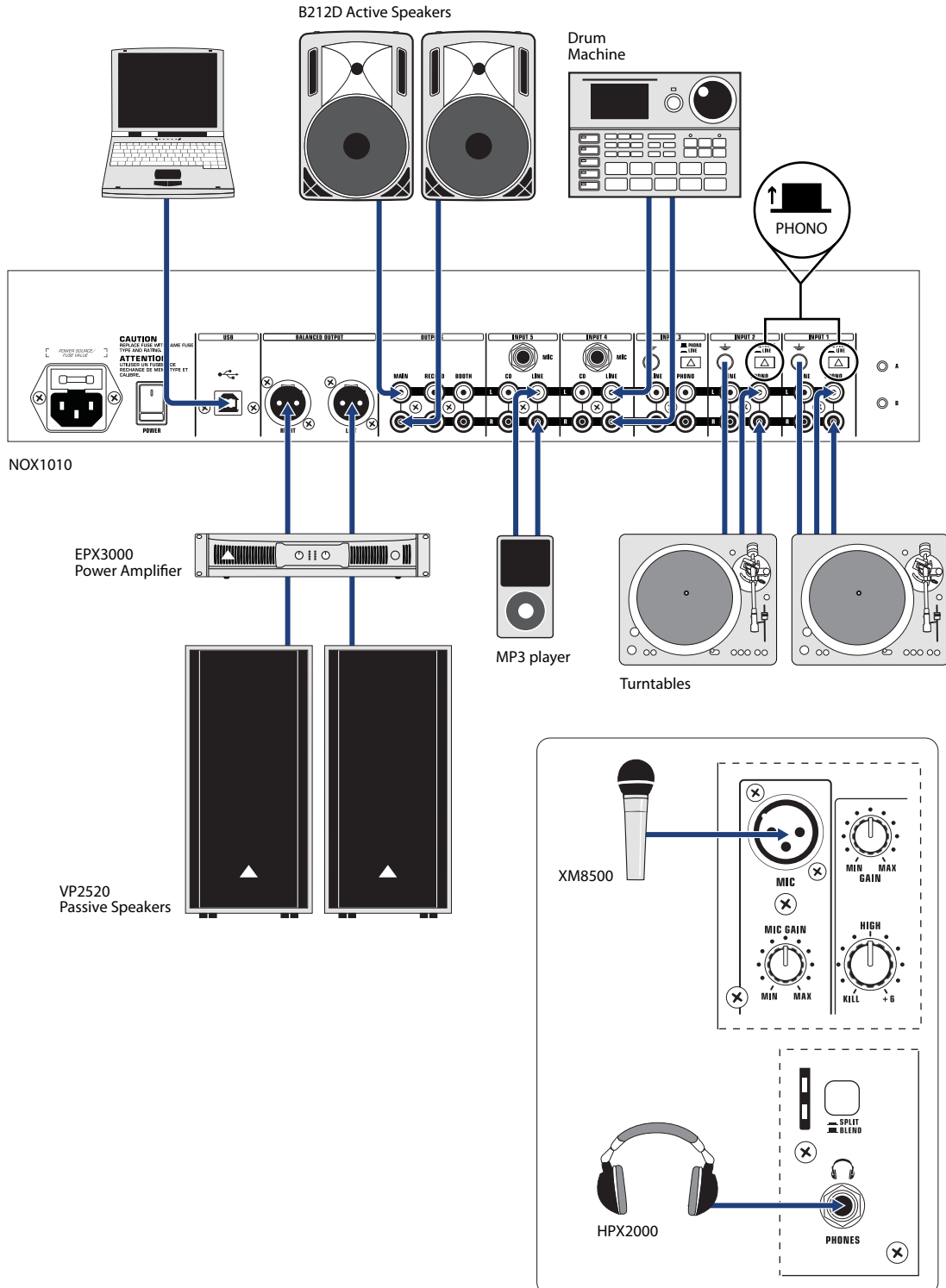

# NOX1010/NOX606 NOX404/NOX303 NOX202

## AUDIO INPUTS

### NOX404/NOX202

Mic in 40 dB gain, TRS, electronically balanced

### NOX1010/ NOX606/NOX303

Mic in 40 dB gain, XLR, electronically balanced

### NOX1010/NOX606/NOX404/NOX303/NOX202

Phono in 40 dB gain, RCA, unbalanced

Line in 0 dB gain, RCA, unbalanced

### NOX404

Return 6 dB gain, ¼" TRS, balanced

### NOX606

Return 0 dB gain, ¼" TS, unbalanced

### NOX1010/NOX404

Aux/CD in 0 dB gain, RCA, unbalanced

## AUDIO OUTPUTS

### NOX202

Main out (A) 21 dBu max, TRS, balanced

### NOX1010/NOX606/NOX404/NOX303

Main out (A) 21 dBu max, XLR, balanced

### NOX1010/NOX404

Main out B 21 dBu max, RCA, unbalanced

### NOX606

Main out B 21 dBu max, ¼" TRS, balanced

Booth/Amp 21 dBu max, ¼" TRS, balanced

FX/Aux send 21 dBu max, ¼" TRS, balanced

### NOX1010/NOX303/NOX202

Booth/Amp 21 dBu max, RCA, unbalanced

### NOX1010/NOX606/NOX303/NOX202

Record out 21 dBu max, RCA, unbalanced

### NOX404

FX/Aux send 0 dBu (dry), ¼" TRS, balanced

### NOX1010/NOX606/NOX404/NOX303/NOX202

Phones out max. 400 mW @ 1 kHz into 75 Ω

## CROSSFADER

### NOX1010/NOX606/NOX404/NOX303/NOX202

Type infinium optical crossfader

## EQUALIZER

### NOX606

Stereo low +6 / -28 dB @ 50 Hz

Stereo mid (1) +6 / -30 dB @ 320 Hz

Stereo mid 2 +6 / -30 dB @ 1.8 kHz

Stereo high +6 / -28 dB @ 10 kHz

Mic low ±15 dB @ 50 Hz

Mic mid (1) ±15 dB @ 250 Hz

Mic mid 2 ±15 dB @ 2.5 kHz

Mic high ±15 dB @ 12 kHz

### NOX1010/NOX606/NOX404/NOX303/NOX202

Stereo low +6 / -31 dB @ 50 Hz

Stereo mid (1) +6 / -20 dB @ 1.2 kHz

Stereo high +6 / -20 dB @ 10 kHz

Mic low ±12 dB @ 50 Hz

Mic high ±12 dB @ 12 kHz

### NOX303/NOX202

Kill low -31 dB @ 50 Hz

Kill mid -20 dB @ 1.2 kHz

Kill high -20 dB @ 10 kHz

## USB

### NOX1010/NOX606/NOX404/NOX303/NOX202

Audio Stereo In/Out

Connector Type B

Converter 16-bit

Sample rate 44.1 / 48 kHz

## DIGITAL EFFECTS PROCESSOR

DSP 24-bit Freescale

A/D - D/A converter 24-bit Delta-Sigma

## SYSTEM SPECIFICATIONS

### NOX1010/NOX606/NOX202

Signal-to-noise ratio >88 dB

### NOX404/NOX303

Signal-to-noise ratio >84 dB

### NOX303/NOX202

Crosstalk >84 dB

### NOX606/NOX404

Crosstalk >70 dB

### NOX1010

Crosstalk >80 dB

# NOX1010/NOX606 NOX404/NOX303 NOX202

## NOX1010/NOX303/NOX202

Distortion (THD)	<0.04% @ 1 kHz
Frequency response	10 Hz - 80 kHz (+0/-3 dB)
Input gain adjustment	46 dB

## NOX606/NOX404

Distortion (THD)	<0.05% @ 1 kHz
------------------	----------------

## NOX404

Frequency response	10 Hz - 70 kHz (+0/-3 dB)
Input gain adjustment	44 dB

## NOX606

Frequency response	10 Hz - 60 kHz (+0/-3 dB)
Input gain adjustment	±12 dB

## POWER SUPPLY

### NOX1010/NOX606/NOX404/NOX303/NOX202

Mains voltage	100-240 V~, 50/60 Hz
---------------	----------------------

## Power consumption

<b>NOX1010</b>	max. 20 W
----------------	-----------

<b>NOX606</b>	max. 27 W
---------------	-----------

<b>NOX404</b>	max. 14 W
---------------	-----------

<b>NOX303</b>	max. 18 W
---------------	-----------

<b>NOX202</b>	max. 12 W
---------------	-----------

### NOX1010/NOX606/NOX404/NOX303/NOX202

Fuse	T 1A H 250 V
------	--------------

Mains connection	Standard IEC receptacle
------------------	-------------------------

## DIMENSIONS/WEIGHT

### Dimensions (H x W x D)

<b>NOX1010</b>	4.3 x 19 x 7.5"/108 x 483 x 191 mm
----------------	------------------------------------

<b>NOX606</b>	4.3 x 18.9 x 15"/108 x 480 x 38 mm
---------------	------------------------------------

<b>NOX404</b>	4.3 x 10.1 x 12.6"/108 x 255 x 320 mm
---------------	---------------------------------------

<b>NOX303</b>	4.3 x 11.5 x 14"/108 x 292 x 355 mm
---------------	-------------------------------------

<b>NOX202</b>	3.9 x 10.1 x 10.8"/100 x 255 x 274 mm
---------------	---------------------------------------

## Weight

<b>NOX1010</b>	6.8 lbs / 3.1 kg
----------------	------------------

<b>NOX606</b>	11.9 lbs / 5.4 kg
---------------	-------------------

<b>NOX404</b>	5.7 lbs / 2.6 kg
---------------	------------------

<b>NOX303</b>	7 lbs / 3.2 kg
---------------	----------------

<b>NOX202</b>	4.8 lbs / 2.2 kg
---------------	------------------

Please note these specifications are preliminary and conceptual in nature, and as such are subject to change as product development progresses. This information is supplied for market research purposes only and is not to be made public in any manner. This document is solely the property of The MUSIC Group, or one of its subsidiaries, and must be surrendered upon request of the owner.

For service, support or more information contact the BEHRINGER location nearest you:

**Europe** Tel.: +49 2154 9206 4149  
Fax: +49 2154 9206 4199

**USA/Canada** Tel.: +1 425 672 0816  
Fax: +1 425 673 7647

**Singapore** Tel.: +65 6845 1800  
Fax: +65 6214 0275

**Australia** Tel.: +61 03 9877 7170  
Fax: +61 03 9877 7870

**Japan** Tel.: +81 3 5281 1180  
Fax: +81 3 5281 1181

©2011 Red Chip Company Ltd. Technical specifications and appearance subject to change without notice. The information contained herein is correct at the time of printing. All trademarks are the property of their respective owners. BEHRINGER accepts no liability for any loss which may be suffered by any person who relies either wholly or in part upon any description, photograph or statement contained herein. 985-10000-00476

behringer.com

