

# GRACE DESIGN



## SPACEBAR

### Modular Microphone Positioning System

User Manual, Revision C, August, 2010

# Table of Contents

Standard pre-configured arrays:.....	4
SB-SUR Surround Tree.....	4
SB-DT Decca Tree .....	4
SB-BL Blumlein .....	4
SB-BLRA Blumlein right angle.....	4
SB-100 1 meter AB bar.....	4
Spacebar modular components:.....	5
SB-AMH Adjustable Mic Holder .....	5
SB-MH Standard Mic Holder.....	5
SB-AMHRA Adjustable Mic Holder, Right Angle.....	5
SB-HB Hanging Bar.....	5
SB-TJ90 90 Degree Tube Joiner.....	6
SB-SMA Stand Mount Adapter 5/8"- 27 thread.....	6
E407 53cm bar .....	6
E414 tube end plug .....	6
E418 Tube Joiner.....	6
E420 105cm bar.....	7
E421 80cm bar.....	7
E422 90 degree stand mount.....	7
E405 42mm thumb nut w/ #10-32 x 7/8" screw.....	7
Spacebar Configurations Detail.....	8
Surround Tree.....	8
Decca Tree.....	9
Blumlein.....	9
AB Stereo.....	11
Hanging Arrays.....	12
Setup Basics.....	12
SB-AMH/SB-MH.....	12
E418 Tube Joiner.....	14
SB-HB Hanging Bar.....	15
Exploded Parts Diagrams.....	18
SB-AMH Adjustable Mic Holder.....	18
SB-MH Standard Mic Holder.....	19
SB-TJ90 90 Degree Tube Joiner.....	20
SB-AMHRA Adjustabe Mic Holder, Right Angle.....	21
SB-SMA Stand Mount Adapter with 5/8"- 27 threads.....	22
SB-SUR Surround Tree.....	23
SB-DT Decca Tree.....	24
SB-BL Blumlein .....	25
SB-BLRA Blumlein Right Angle.....	26
SB-100 1 Meter AB bar.....	27
SB-HB Hanging Bar.....	28
Revision history.....	29

Welcome and thanks for purchasing a Grace Design Spacebar microphone positioner. We build all of our products to be completely reliable and easy to use, so you can concentrate on making great recordings, not struggling with complicated equipment or difficult product manuals. While you will find the Spacebar is completely straightforward to use, we do ask that you familiarize yourself with this product manual to help avoid any common user difficulties.



The Grace Design Spacebar modular microphone positioning system allows for precise and repeatable setting of microphone capsule spacing and angle of incidence in a wide array of microphone configurations. With precision scales for angle and distance engraved on the Spacebar components, it becomes easy to make perfectly repeatable stereo and multichannel microphone setups.

The Spacebar modular system components can be purchased in pre-configured assemblies for several standard microphone arrays. As well, it is possible to build a virtually limitless range of microphone holding structures to meet any need.

The Spacebar system is precision fabricated from machined aircraft aluminum, brass, and stainless steel. If properly cared for it should last a lifetime. In the event that you encounter any technical or operational difficulties with this or any Grace Design products, please feel free to contact us at 303-443-7454, 9 to 5, Monday through Friday, MST. Or you can email any questions to: [info@gracedesign.com](mailto:info@gracedesign.com)

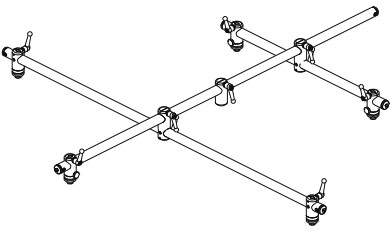
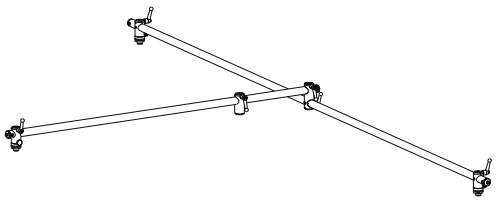

## Standard Pre-configured Arrays:

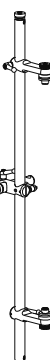
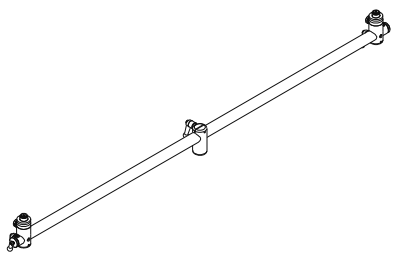
<p><b>SB-SUR</b> Surround Tree Holds 5 microphones</p>	 A diagram of a surround microphone array consisting of five microphones. Two microphones are positioned at the top, and three are positioned at the bottom, all connected to a central hub.
<p><b>SB-DT</b> Decca Tree Standard 3 microphone tree 2M x 1M</p>	 A diagram of a Decca tree microphone array consisting of three microphones. Two microphones are positioned at the top, and one is positioned at the bottom, all connected to a central hub.
<p><b>SB-BL</b> Blumlein Holds standard large diaphragm microphones in a vertical Blumlein configuration.</p>	 A diagram of a vertical Blumlein microphone array consisting of two microphones positioned vertically on a central bar.
<p><b>SB-BLRA</b> Blumlein right angle Holds RCA 44 type ribbon microphones in a vertical Blumlein configuration.</p>	 A diagram of a vertical Blumlein right angle microphone array consisting of two microphones positioned vertically on a central bar, with a right-angle bend in the bar.
<p><b>SB-100</b> 1 meter AB bar Straight 1 meter stereo bar. Can be extended to 2 meters.</p>	 A diagram of a straight 1 meter stereo bar (AB bar) consisting of two microphones positioned horizontally on a central bar.

## Spacebar Modular Components:

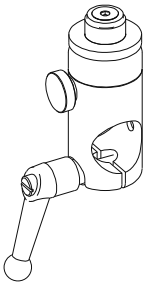
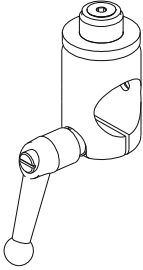
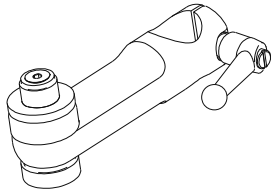
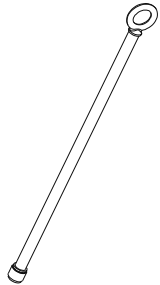
<p><b>SB-AMH</b> Adjustable Mic Holder</p> <p>Mic holder with precision angle scale. 5 degree markings from +90 to -90 degrees.</p>	
<p><b>SB-MH</b> Standard Mic Holder</p>	
<p><b>SB-AMHRA</b> Adjustable Mic Holder, Right Angle</p>	
<p><b>SB-HB</b> Hanging Bar</p>	

**SB-TJ90** 90 Degree Tube Joiner

Allows any two 7/8" tubes to be joined at a 90 degree angle.

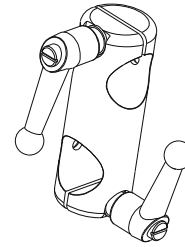

**SB-SMA** Stand Mount Adapter 5/8" - 27 thread

Comes with 3/8-16 European style thread adapter.

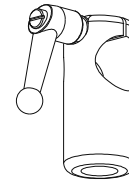

**E407** 53cm bar

7/8" diameter, LASER etched scale reads 25-0-25cm.

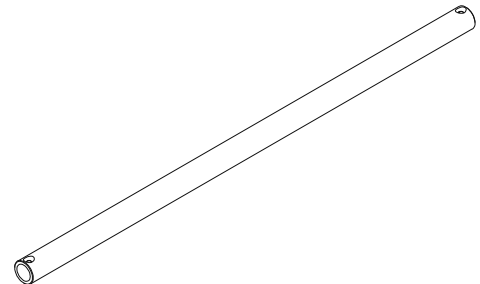

**E414** tube end plug

Attaches to the end of any of the 7/8" tubes. Provides a threaded hole for attaching hooks for guide lines or an E414 24m thumb screw to provide a safety stop for microphone holders.

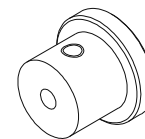

**E418** Tube Joiner

Joins any two 7/8" tubes. Made from very strong 304 stainless steel.

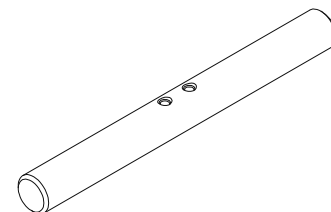

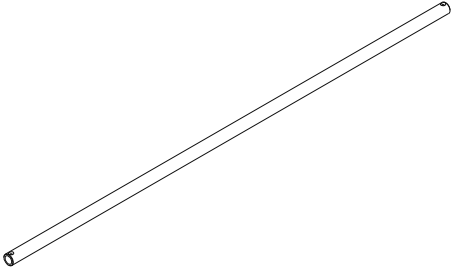
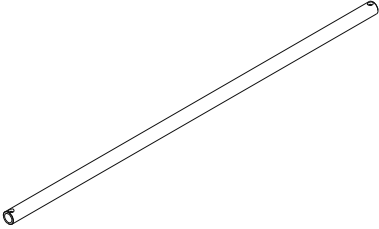
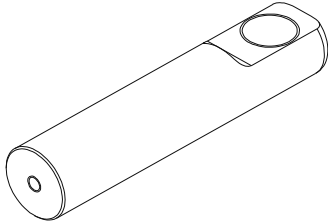
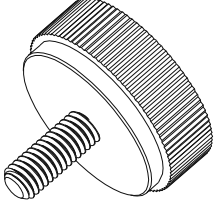
<p><b>E420</b> 105cm bar</p>	
<p><b>E421</b> 80cm bar</p>	
<p><b>E422</b> 90 degree stand mount</p>	
<p><b>E405</b> 42mm thumb nut w/ #10-32 x 7/8" screw</p>	

Note: All components which feature microphone mounts come standard with 5/8-27 American standard threads. As well, all microphone mounts can be ordered with the European standard 3/8-16 British Standard Whitworth threads. These part numbers will have a - BSW suffix.

# Spacebar Configurations Detail

## Surround Tree

The SB-SUR system allows for mounting of 5 microphones. In its standard configuration three microphones can be mounted as a “front triplet” and two microphones can be mounted as a rear pair. All microphone spacings can be precisely adjusted using the engraved centimeter scales on the bars. Also, all microphone angles of incidence can be precisely adjusted in 5 degree increments.

The front left and right microphone holder spacing can be adjusted from 6cm to 102cm if using the E420 105cm bar and 6cm to 50cm E407 53cm bar.

For surround microphone arrays using the SB-SUR system we highly recommend visiting <http://www.mmad.info>. This website was created by Michael Williams who has written much about multichannel microphone array design. It contains an interactive design decision sequence for tailoring your microphone configuration to your specific acoustic venue. The underlying theory for this design approach is contained in a series of AES papers written by Michael Williams.

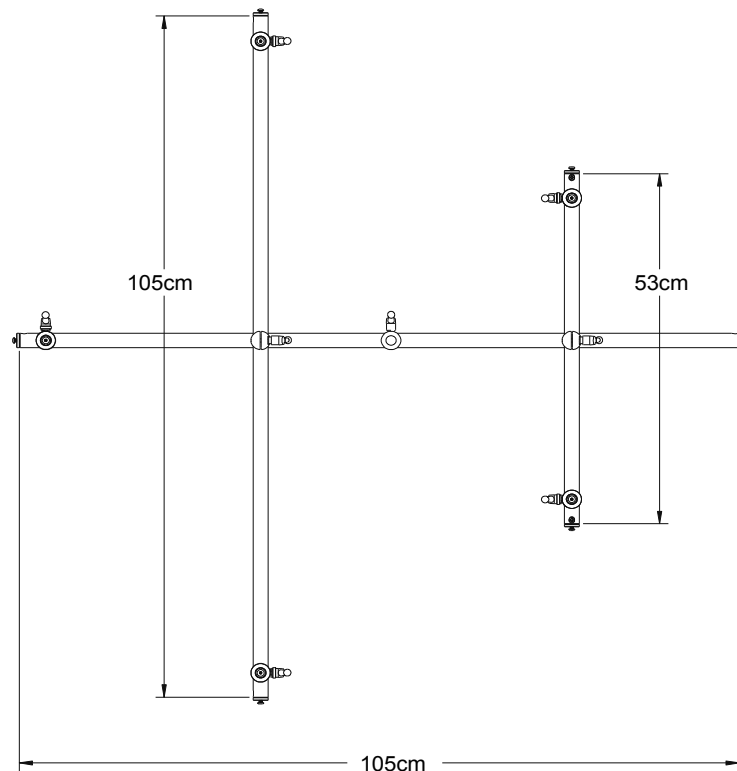

fig 1: Surround Tree

See the SB-SUR system [exploded parts diagram](#) for a list of included components.



## Decca Tree

This classic microphone configuration was developed by Decca Records engineers in the 1950s. The Spacebar Decca Tree configuration provides a simple, precise, and easy to set up solution for this technique. The standard Spacebar Decca Tree comes with three E420 1 meter tubes, an SB-SMA 5/8"-27 stand mount adapter and three SB-AMH adjustable mic holders. These are configured to provide a 2 meter spacing between left and right microphones and a center microphone 1 meter forward. Since the stand mount adapter can move front to back on the 1 meter tube it should be located at the balance point for maximum stability.

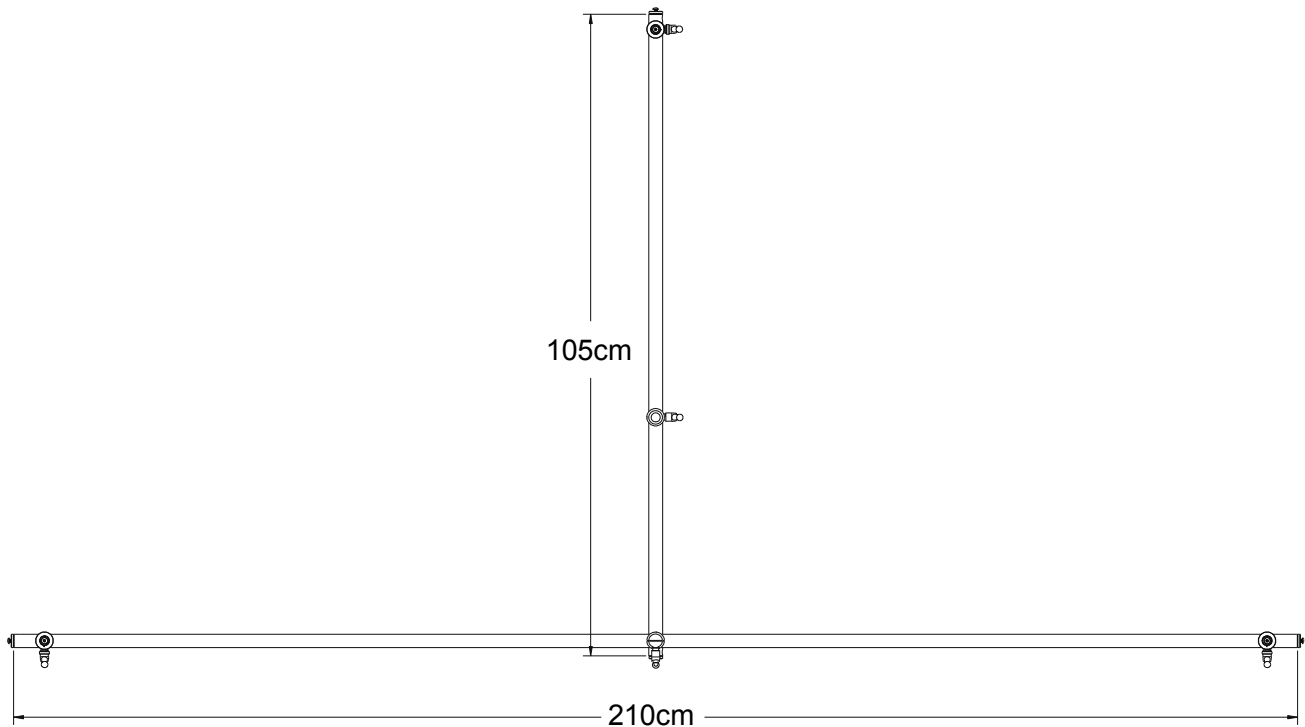

fig. 2: Decca Tree

See the SB-DT system [exploded parts diagram](#) for a list of included components.

## Blumlein

The Blumlein stereo micing technique was pioneered by Alan Blumlein in the 1930s. The Spacebar Blumlein configuration allows for holding two figure-8 microphones on the same vertical axis and at a precise 90 degree angle of incidence. Two types of mic holder are available depending on the microphones being used. For RCA 44 and RCA 77 type mics and their derivatives the SB-AMHRA holder should be used. Most other microphones can be mounted with the SB-MH standard mic holder.

A unique feature of the Spacebar Blumlein configuration is that the whole vertical tube assembly can be rotated on a horizontal axis allowing the mics to be aimed up or down

relative to the horizontal plane. This can be very useful when micing and ensemble from above on a tall stand.

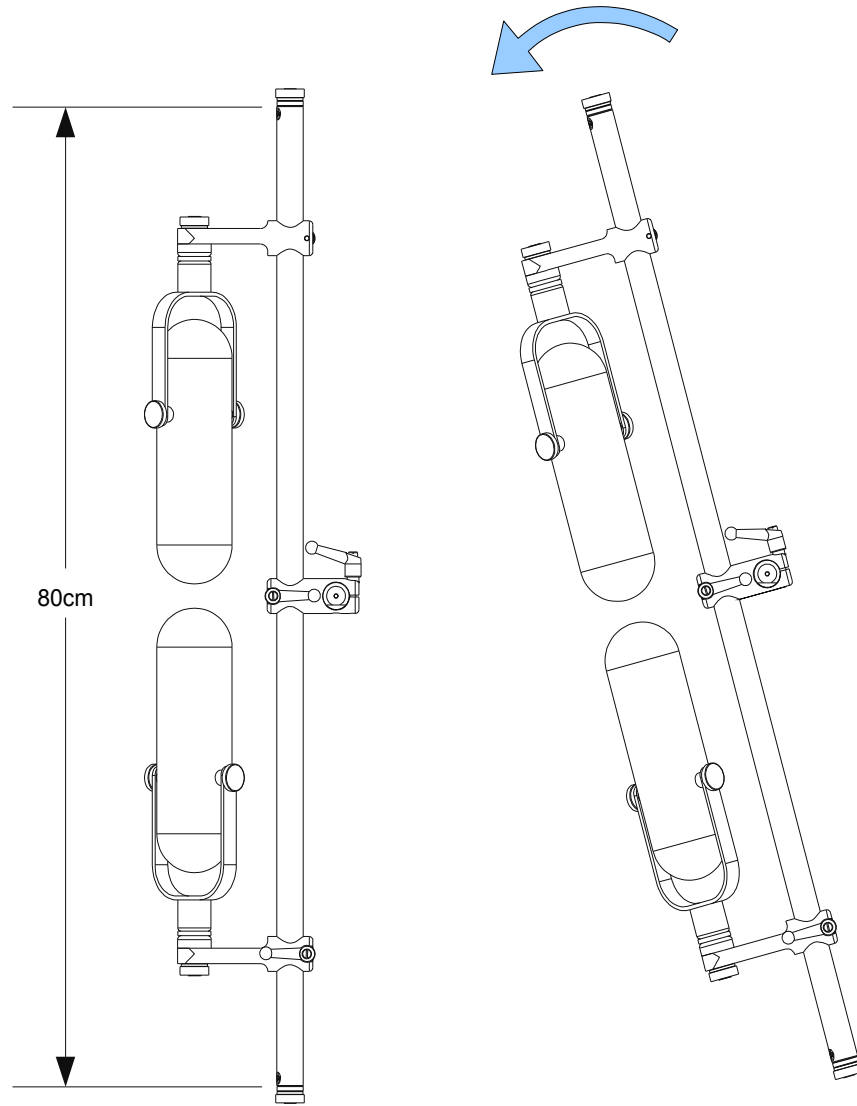

fig. 3: **SB-BLRA Blumlein with SB-AMHRA right angle mic holders (shown with RCA 44 type mics)**

See the SB-BLRA system [exploded parts diagram](#) for a list of included components.

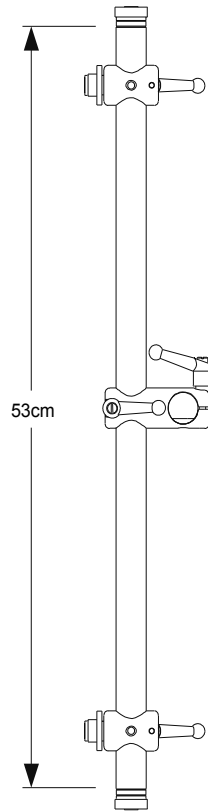

fig. 4: **SB-BL Blumlein with SB-MH standard mic holders**

See the SB-BL system [exploded parts diagram](#) for a list of included components.

## AB Stereo

The AB Stereo microphone technique typically uses two omni-directional microphones spaced apart by a distance. The SB-100 configuration is basically a 1M wide stereo bar. With the addition of another E420 tube and a E418 joiner tube, the SB-100 becomes an SB-200 2 meter stereo bar.

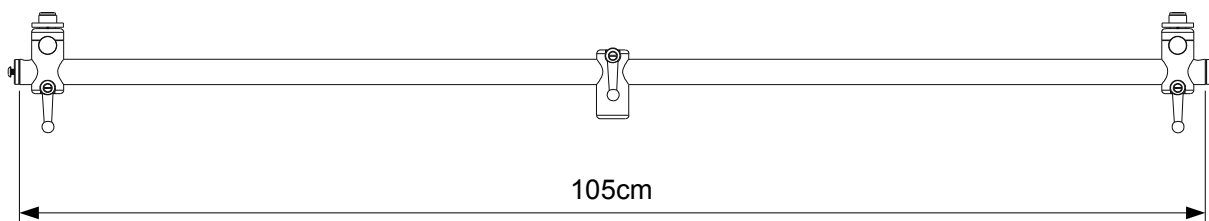

fig. 5: **SB-100**

See the SB-100 system [exploded parts diagram](#) for a list of included components.

## Hang Arrays

For applications that require hanging a microphone array from a ceiling, the SB-HB hanging bar can be used. The SB-HB can be used with the SB-SUR surround tree, SB-DT Decca tree, and the SB-100 AB bar. The SB-HB has a 1 inch eye-bolt on one end and threads into the SB-SMA stand mount adapter at the other. The SB-HB can be ordered in two versions:

1. SB-HB-1M with a guide line yoke sized for 1 meter wide bars.
2. SB-HB-2M with a guide line yoke sized for 2 meter wide bars.

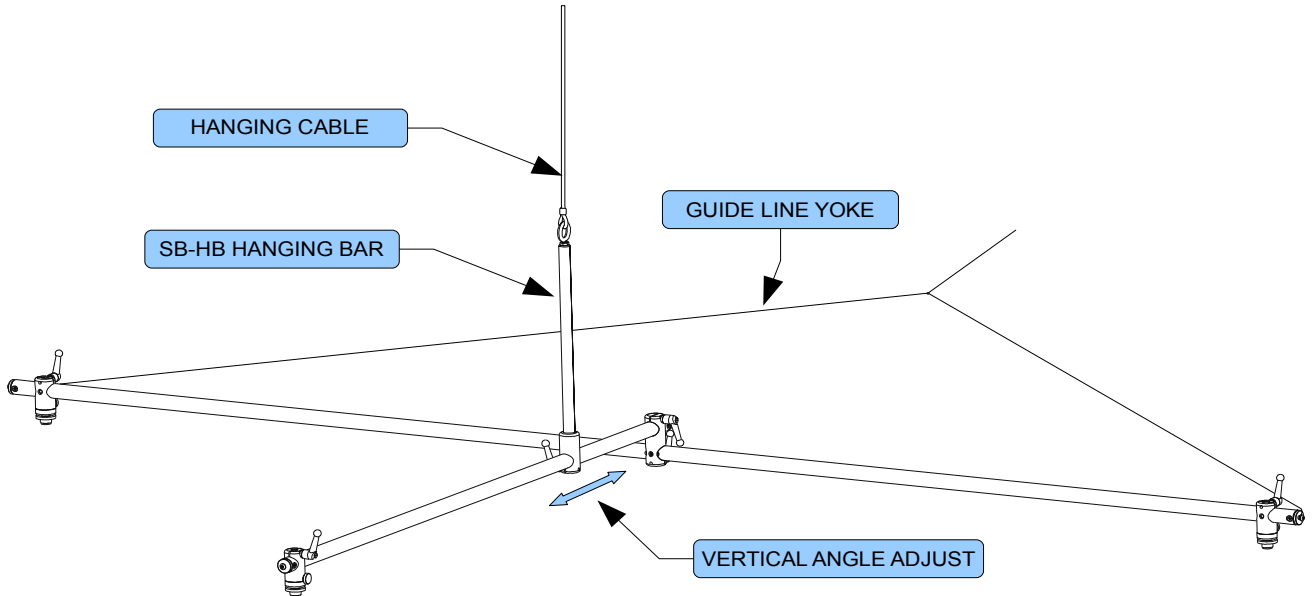

fig. 6: Decca Tree with SB-HB Hanging Bar

## Setup Basics

### SB-AMH/SB-MH

All of the modular microphone holder assemblies use adjustable clamping handles to tighten and loosen the holder from the tube it is mounted on. Turning the handle clockwise will tighten or “clamp” the holder in position on the tube. The clamping action is very secure and does not require extreme torque on the handle. As well, the final position of the handle can be adjusted by pulling on the handle while rotating. This allows the handle to be adjusted so that it can be at a convenient angle for tightening or loosening.

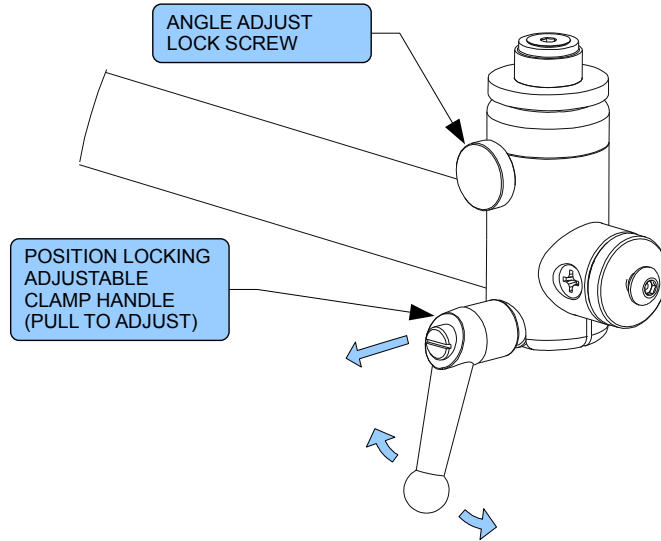

fig. 7: SB-AMH Adjustable Mic Holder

The angle of incidence of a mounted microphone can be precisely set by using the angle indicating protractor markings which are engraved on the front of the SB-AMH. The angle is indicated from +90 to -90 degrees in 5 degree increments. **The angle adjust thumb screw must be loosened before rotating the upper portion of the microphone holder.**

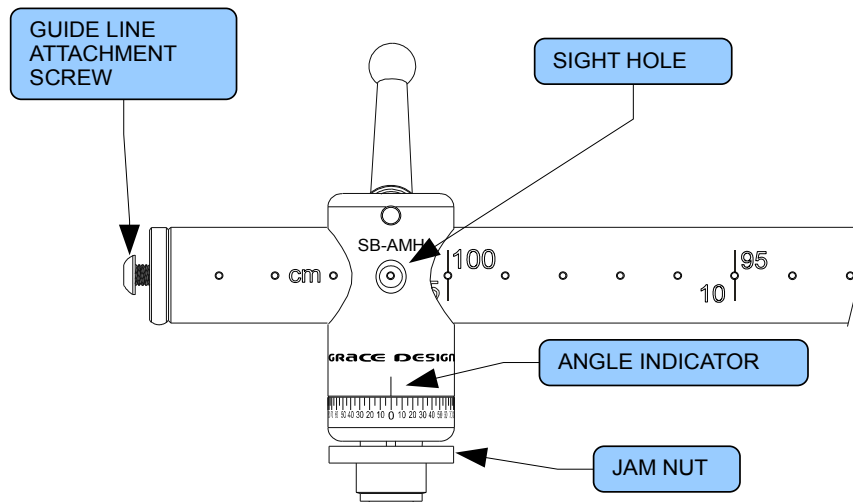

fig. 8: SB-AMH Adjustable Mic Holder showing protractor markings and sight hole

To calibrate the angle of incidence, follow these steps:

- A) Loosen locking thumb screw and rotate mic holder so that 0 degrees is indicated. Then re-tighten the thumb screw.
- B) Thread on the microphone clip and orient it so that it is perpendicular to the Spacebar tube.
- C) Lock the microphone clip in place by tightening the jam nut against it.
- D) Now the angle of the microphone can be precisely adjusted by loosening the thumb screw and rotating the microphone.

The location of the microphone holder can be precisely set by using the numeric scales engraved on the tubes. The SB-MH and SB-AMH feature a sight hole that allows microphone holder to be positioned on the centimeter indicator circles. The SB-TJ90 tube joiner also has sight holes allowing for proper centering of cross bars and measurement between cross bars and microphone holders. The scales on the various bars are indicated as follows:

- E420 indicated in centimeters and reads 0 to 105cm from left to right and 105 to 0cm right to left.
- E421 indicated in centimeters and reads 40-0-40cm.
- E407 indicated in centimeters and reads 25-0-25cm from the center.

## E418 Tube Joiner

The E418 tube joiner is used to connect any two of the 7/8" diameter tubes. Typically used for the 2 meter segment of the Decca Tree or for very wide stereo bars. To join two tubes simply slide the tube joiner bar into one of the tubes and secure with the 8-32 x 1/4" flat head screw. Next, slide the second tube over the joiner bar and secure with the other screw. See diagram below.

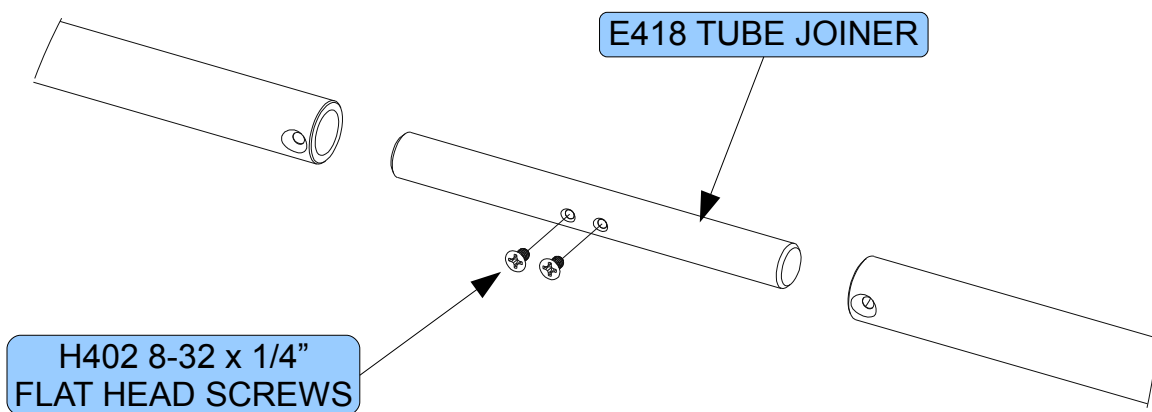

fig. 9: E418 tube joiner bar assembly

## SB-HB Hanging Bar

The SB-HB assembly threads into the SB-SMA stand mount adapter as shown below.

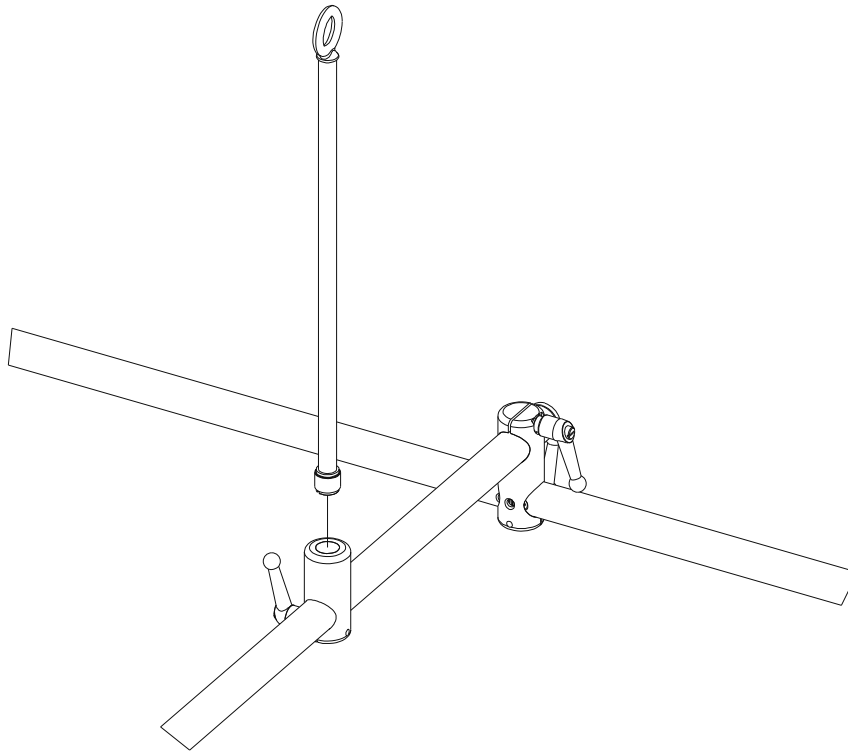

fig. 10: SB-HB assembly

When hanging the microphone array can be aligned to the sound source by attaching the supplied guide line yoke to the ends of the 7/8" tubes. With user supplied line the yoke can be tied to an appropriate anchor point in the venue. These yoke lines are adjustable so that the microphone array can be precisely aimed. Adjustments can be made by slipping the mono-filament line through the shrink tubing to shorten one side of the yoke while effectively lengthening the other.

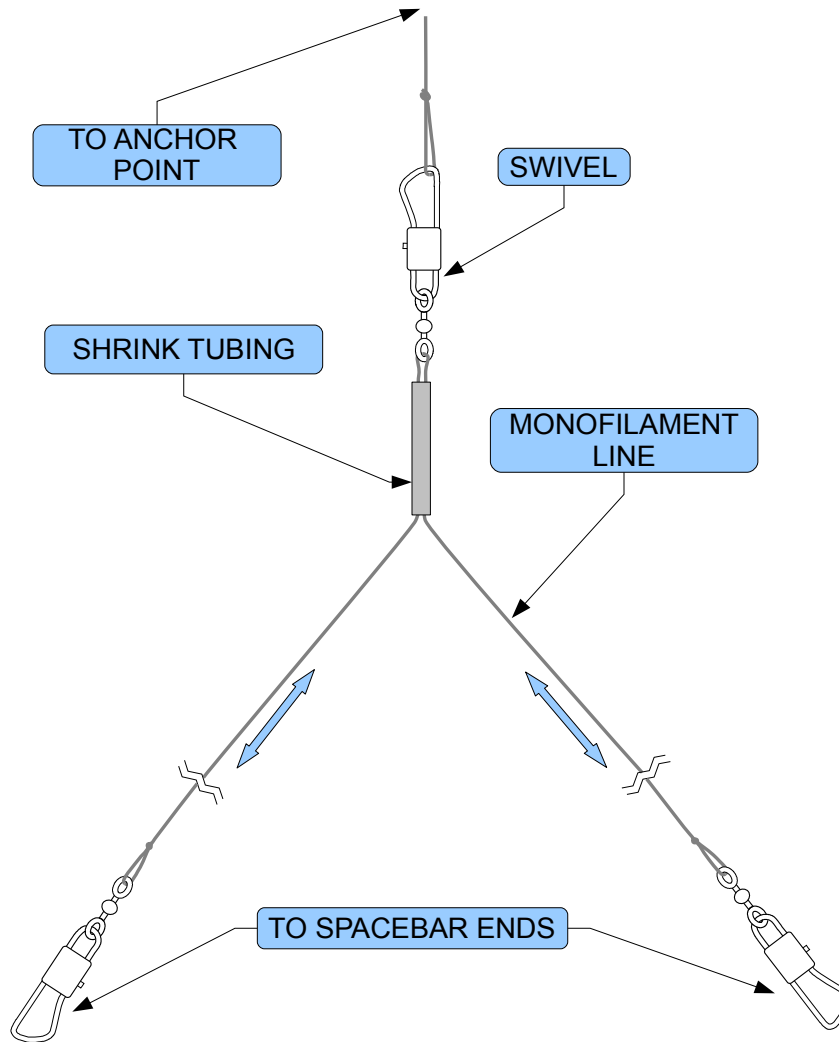

fig 11. Guide Line Yoke

The ends of the yoke guide lines attach to the s-hooks on the ends of whatever bar is being used. The s-hooks (supplied with your Spacebar system) must be mounted to the end plugs of the tube with the supplied #10-32 x 1/2" button head cap screw. Use a 1/8" hex wrench. Do not tighten the screw so much that it binds the s-hook. The screw has a thread locking compound applied to its threads so it will not loosen after screw is installed.



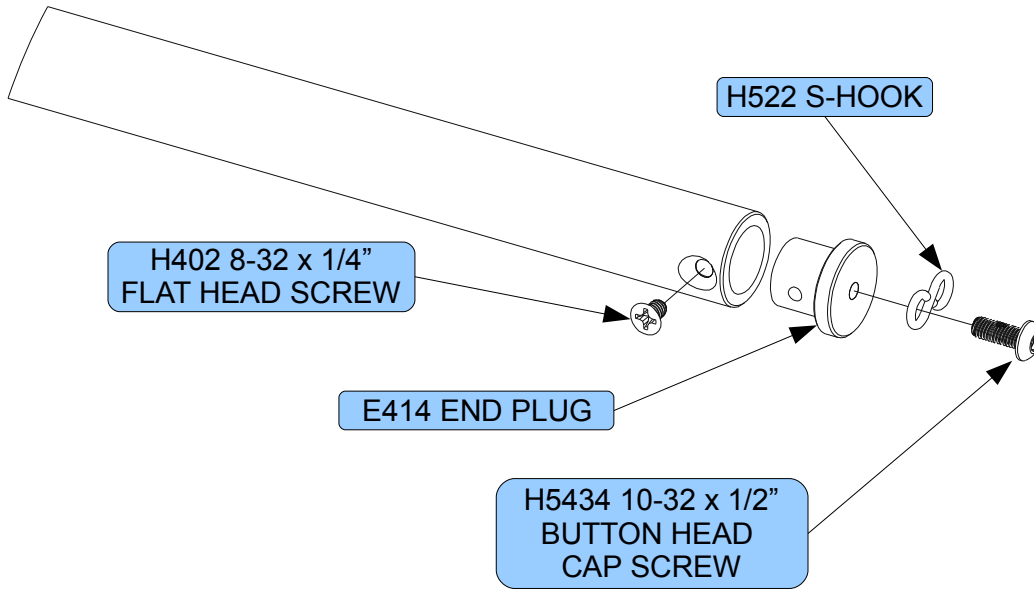

fig. 12: Bar end s-hook installation

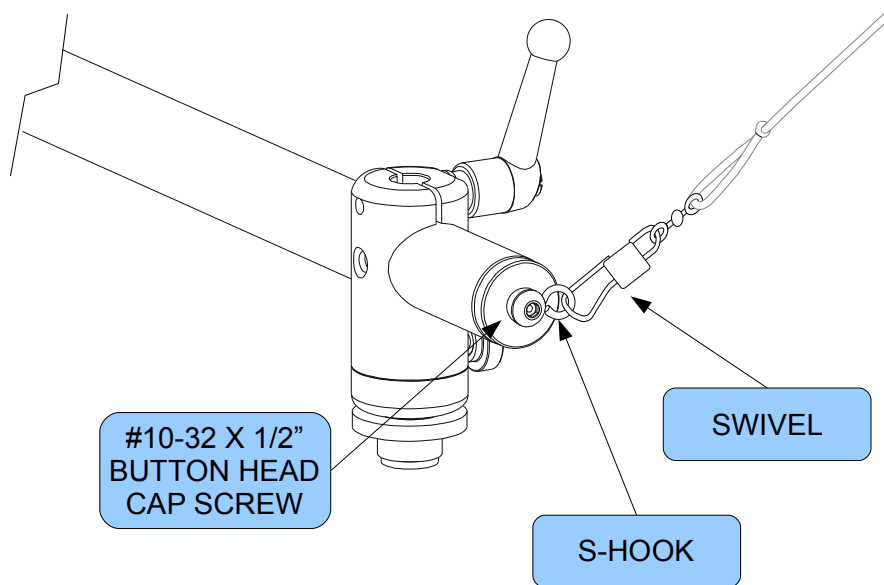
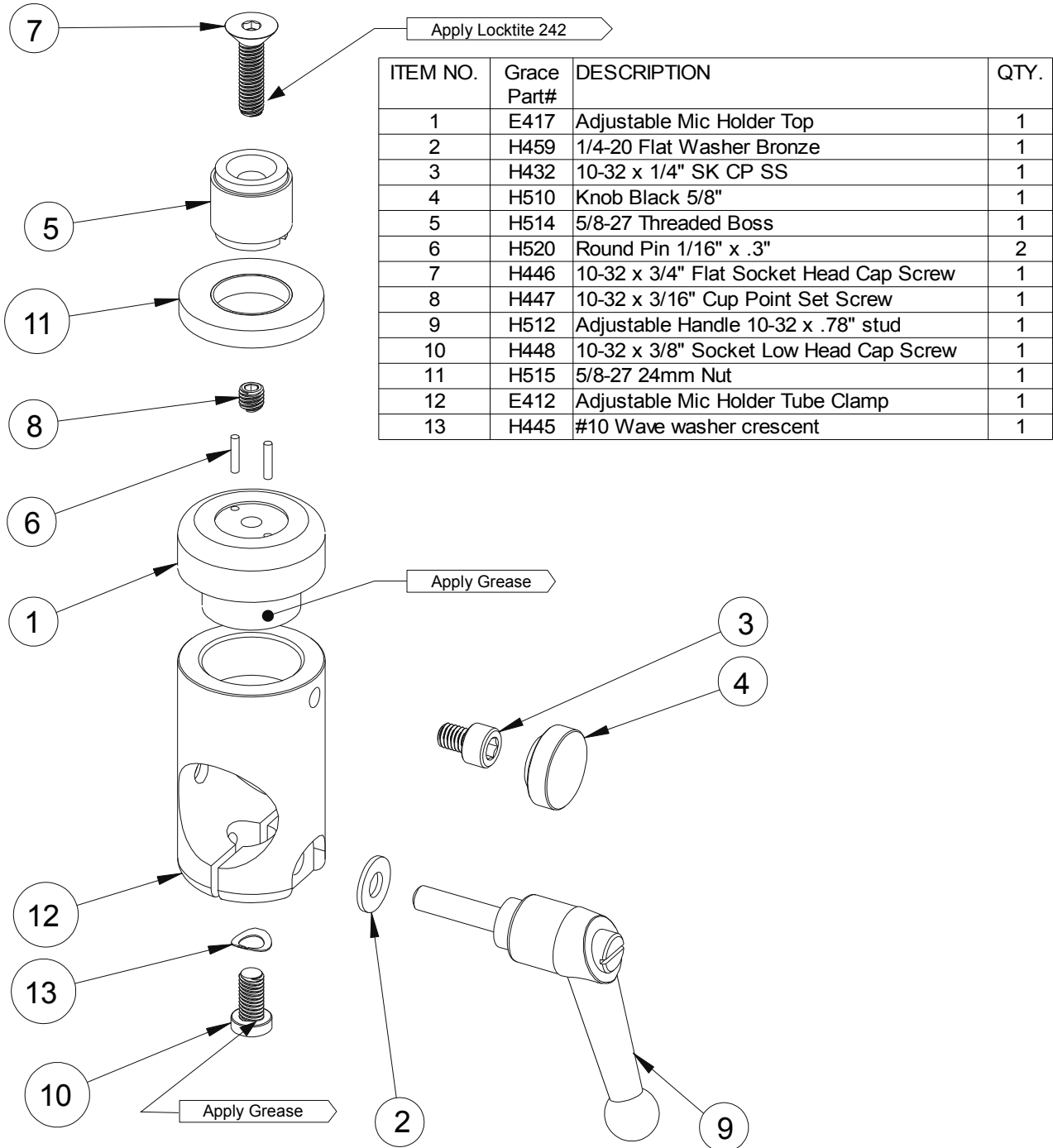

fig. 13: guide line yoke attachment

The vertical angle of the array can be adjusted by moving the stand mount adapter forward or rearward of the balance point.

# Exploded Parts Diagrams

## SB-AMH Adjustable Mic Holder



# SB-MH Standard Mic Holder

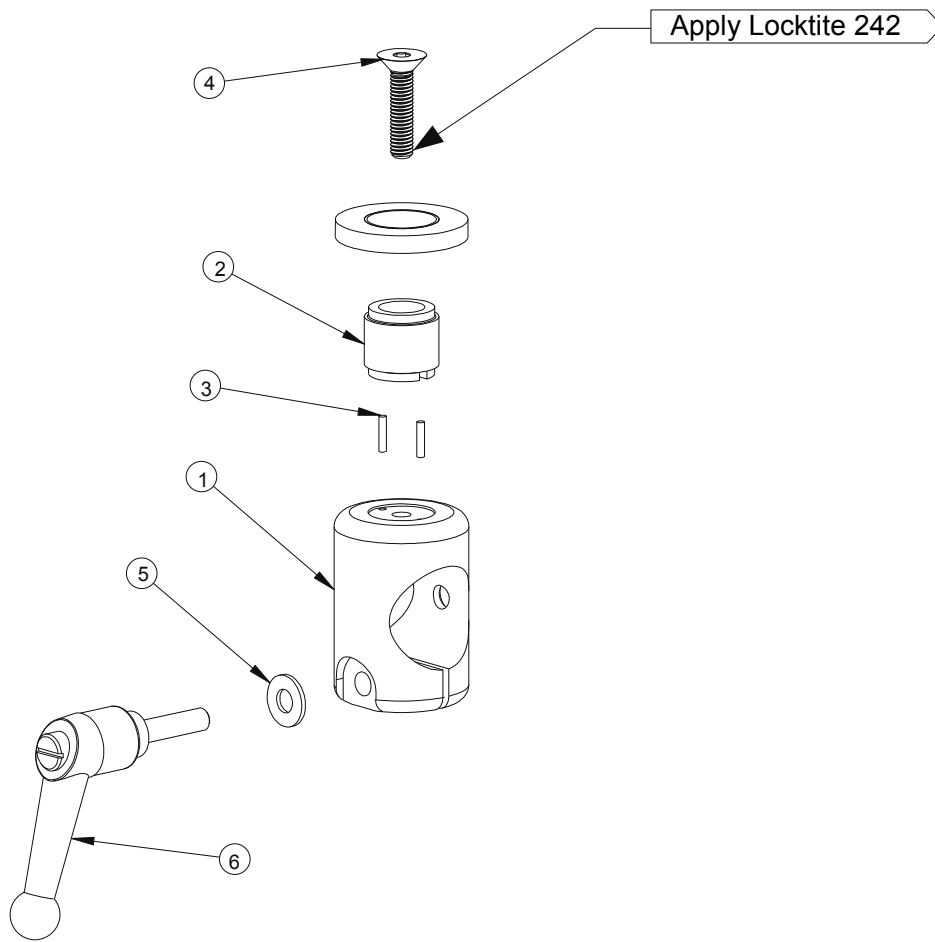

ITEM NO.	Grace Part#	DESCRIPTION	QTY.
1	E408	Mic Holder 7/8" Tube Clamp	1
2	H514	5/8-27 Threaded Boss	1
3	H520	Round Pin 1/16" x .3"	2
4	H436	10-32 x 7/8" FL SC SS	1
5	H459	1/4-20 Flat Washer Bronze	1
6	H512	Adjustable Handle 10-32 x .78" stud	1
7	H515	5/8-27 24mm Nut	1

## SB-TJ90 90 Degree Tube Joiner

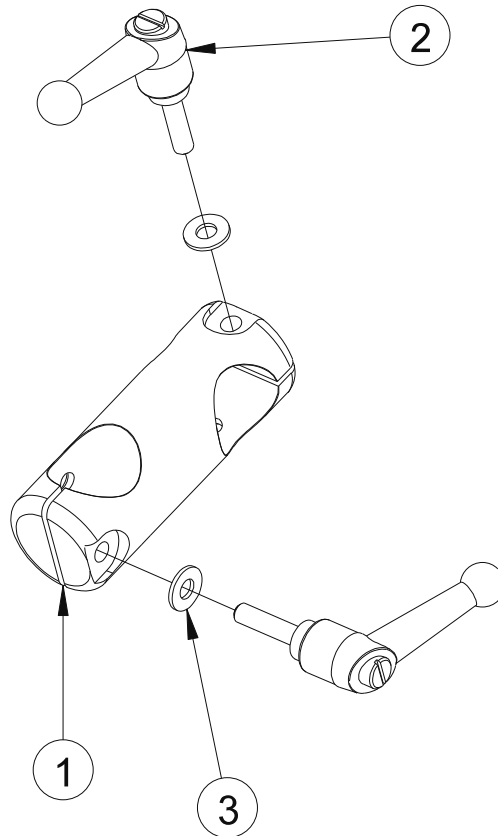

ITEM NO.	Grace Part#	DESCRIPTION	QTY.
1	E415	90 Degree Tube Joiner	1
2	H512	Adjustable Handle 10-32 x .78" stud	2
3	H459	1/4-20 Flat Washer Bronze	2

## SB-AMHRA Adjustabe Mic Holder, Right Angle

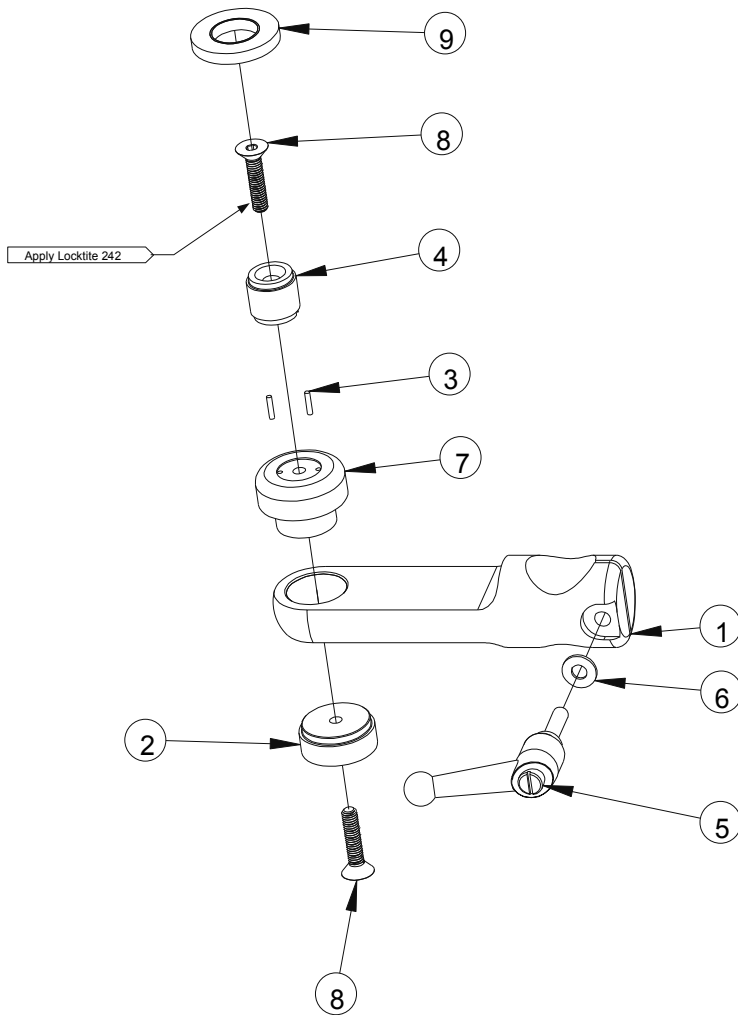

ITEM NO.	Grace Part #	DESCRIPTION	QTY.
1	E413	Mic Holder Right Angle 3/4" Tube Clamp	1
2	E405	24mm Nut 10-32 Thread	1
3	H520	Round Pin 1/16" x .3"	2
4	H514	5/8-27 Threaded Boss	1
5	H512	Adjustable Handle 10-32 x .78" stud	1
6	H459	1/4-20 Flat Washer Bronze	1
7	E417	Adjustable Mic Holder Top	1
8	H436	10-32 x 7/8" FL SC SS	2
9	H515	5/8-27 24mm Nut	1

## SB-SMA Stand Mount Adapter with 5/8"- 27 threads

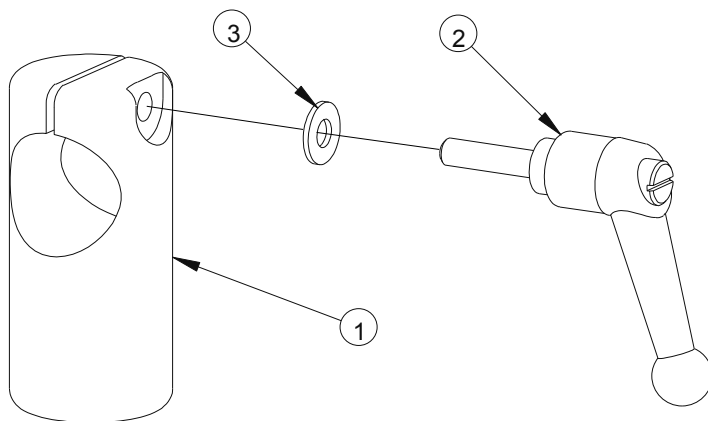

ITEM NO.	Grace Part #	DESCRIPTION	QTY.
1	E416	Stand Mount 5/8-27 Threads 7/8" Tube Clamp	1
2	H512	Adjustable Handle 10-32 x .78" stud	1
3	H459	1/4-20 Flat Washer Bronze	1

## SB-SUR Surround Tree

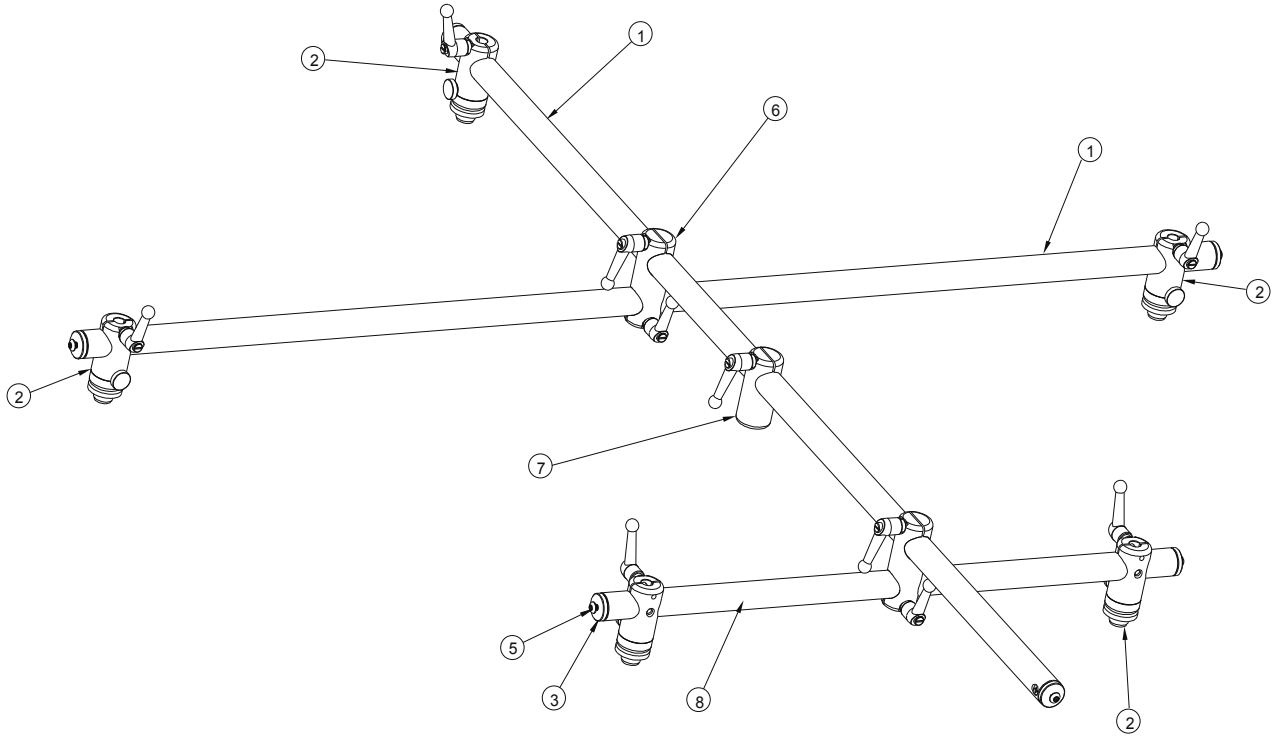

ITEM NO.	Grace Part #	DESCRIPTION	QTY.
1	E420	105 cm x .875" OD Tube	2
2	SB-AMH	Adjustable Microphone Holder	5
3	E414	End Plug for 0.626" ID tube	6
4	H402	8-32 x 1/4" Flat Head Machine Screw	6
5	H434	10-32 x 1/2" Button Head Cap Screw	6
6	SB-TJ90	90 Degree Tube Joiner	2
7	SB-SMA	Stand Mount Adapter	1
8	E407	Tube 53cm x .875"OD x .625" ID	1

# SB-DT Decca Tree

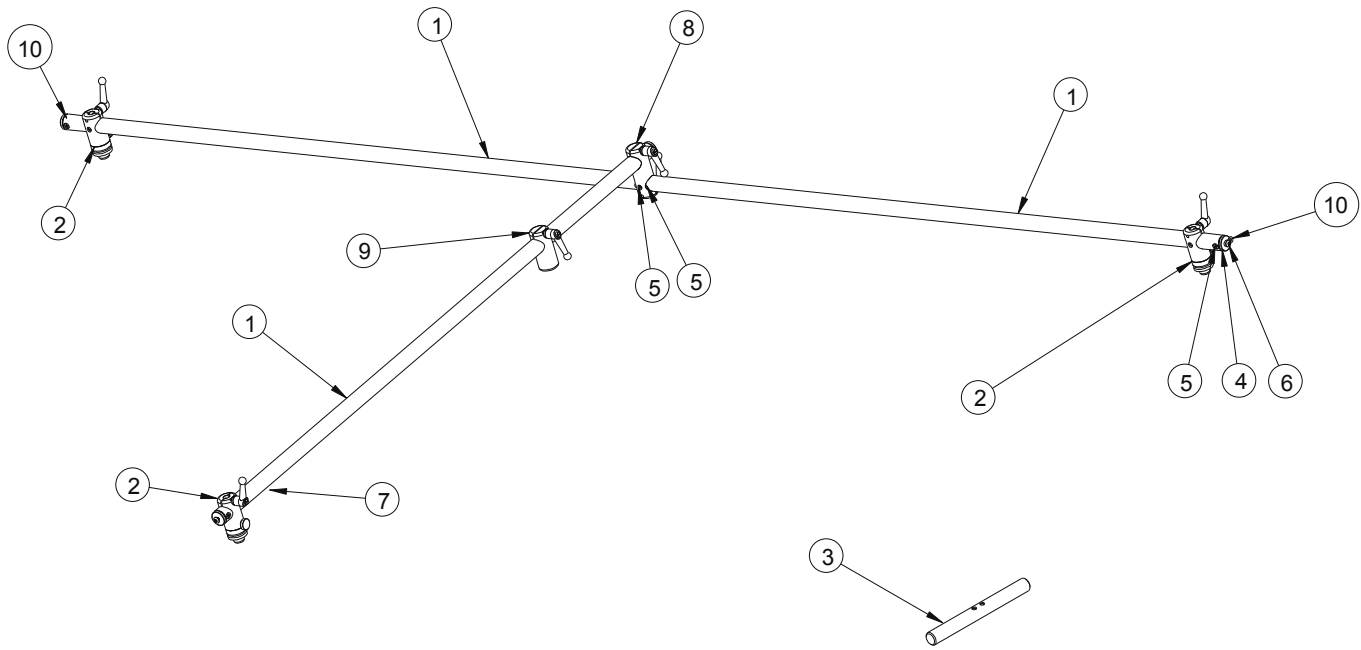

ITEM NO.	Grace Part #	DESCRIPTION	QTY.
1	E420	105 cm x .875" OD Tube	3
2	SB-AMH	Adjustable Microphone Holder	3
3	E418	Tube Joiner Bar	1
4	E414	End Plug for 0.626" ID tube	4
5	H402	8-32 x 1/4" Flat Head Machine Screw	6
6	H434	10-32 x 1/2" Button Head Cap Screw	4
7	E423	Cable Clip for 7/8" tube	6
8	SB-TJ90	90 Degree Tube Joiner	1
9	SB-SMA	Stand Mount Adapter 5/8-27 Threads	1
10	H522	S-Hook 13/64" Dia	2



## SB-BL Blumlein

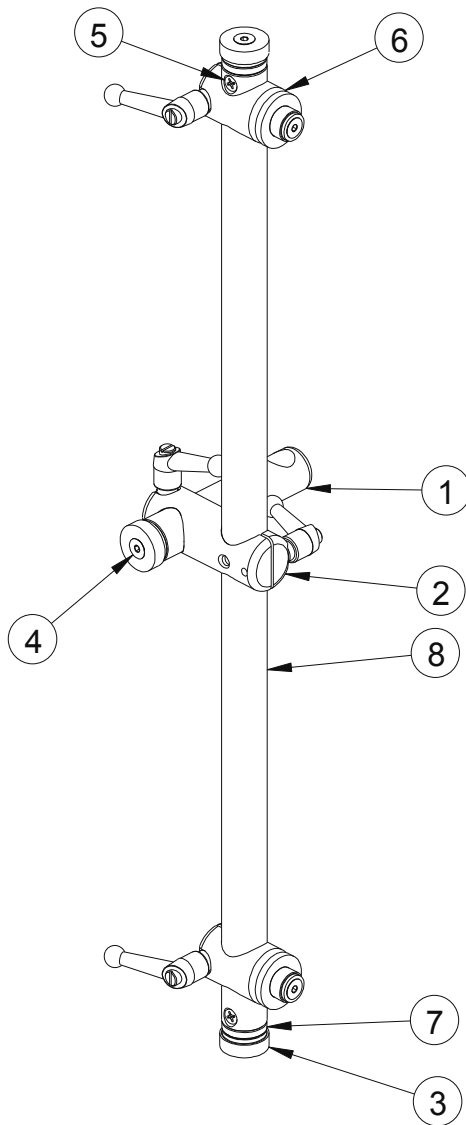

ITEM NO.	Grace Part #	DESCRIPTION	QTY.
1	E422	Stand Mount Right Angle	1
2	SB-TJ90	90 Degree Tube Joiner	1
3	E405	24mm Nut 10-32 Thread	3
4	H436	10-32 x 7/8" FL SC SS	3
5	H402	8-32 x 1/4" Flat Head Machine Screw	2
6	SB-MH	Mic Holder	2
7	E414	End Plug for 0.626" ID tube	2
8	E407	Tube 53cm x .875"OD x .625" ID	1

## SB-BLRA Blumlein Right Angle

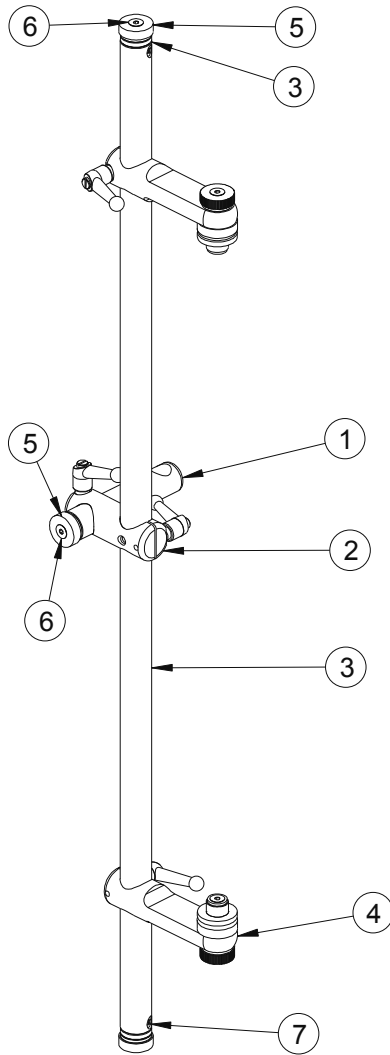

Grace Part #	DESCRIPTION	QTY.	
E422	Stand Mount Right Angle	1	
SB-TJ90	90 Degree Tube Joiner	1	
E421	80 cm x .875" OD Tube	1	
SB-AMHRA	Adjustable Mic Holder, Right Angle	2	
E405	24mm Nut 10-32 Thread	3	
H436	10-32 x 7/8" FL SC SS	3	
H402	8-32 x 1/4" Flat Head Machine Screw	2	
E414	End Plug for 0.626" ID tube	2	

## SB-100 1 Meter AB bar

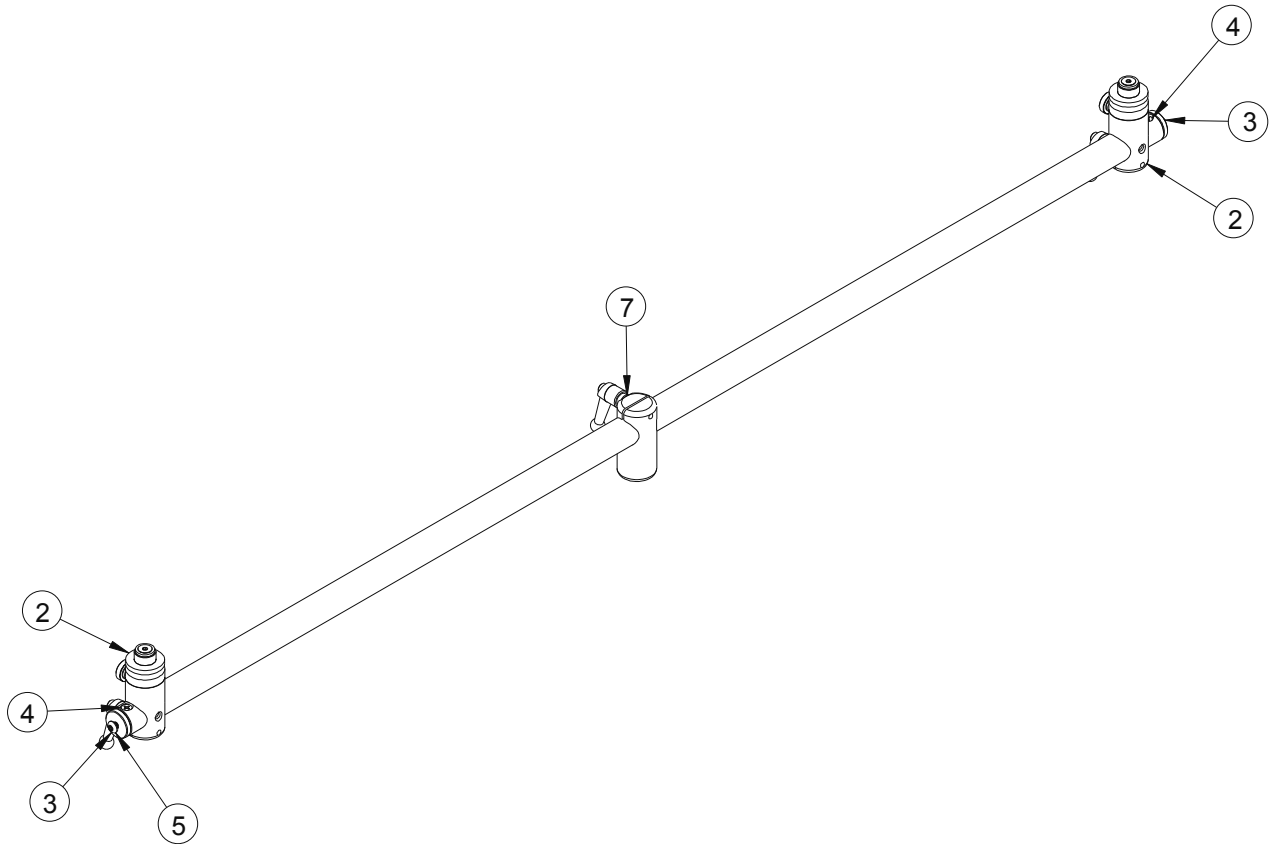

ITEM NO.	Grace Part	DESCRIPTION	QTY.
1	E420	105 cm x .875" OD Tube	1
2	SB-AMH	Adjustable Microphone Holder	2
3	E414	End Plug for 0.626" ID tube	2
4	H402	8-32 x 1/4" Flat Head Machine Screw	2
5	H434	10-32 x 1/2" Button Head Cap Screw	2
6	E423	Cable Clip for 7/8" tube	4
7	SB-SMA	Stand Mount Adapter	1

## SB-HB Hanging Bar

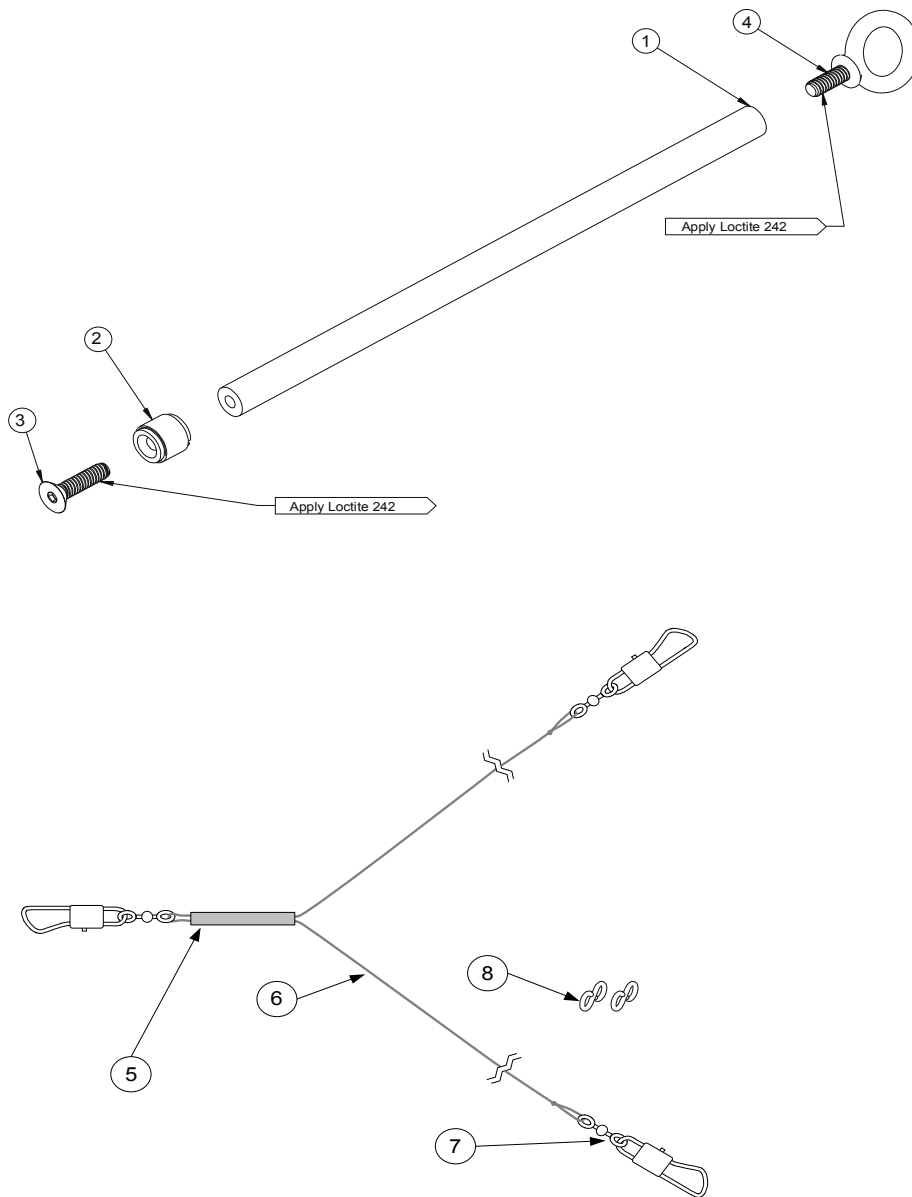

ITEM NO.	PartNo	DESCRIPTION	QTY.
1	E428	Hanging Bar	1
2	H521	5/8-27 Threaded Boss (modified H514)	1
3	H496	1/4-20 X 1 Flat Head Socket St Zn 82 Degree	1
4	H495	Eye bolt 1/4-20 X 1" Cut to 5/8"	1
5	W500	1/16" DIA Shrink tubing, Black	1"
6	H524	Monofilament line .016" DIA for 1 meter bar	78"
6	H524	Monofilament line .016" DIA for 2 meter bar	140"
7	H523	#10 Barrel Swivel with safety hook	3
8	H522	S-Hook, closed, 13/64" Dia, 5/64" Wire	

## ***Revision history***

Rev.	Description	Date	Initials
A	Initial release	10/07/09	MBG
B	Added SB-HB parts diagram and bill of materials.	12/07/09	MBG
B	Fixed SB-BLRA bill of materials to show item number column. Also fixed bom to show proper tube (80cm E421)	12/07/09	MBG
B	Corrected monofilament line yoke drawing to show proper swivel attachment.	12/07/09	MBG
B	Changed references to mic cable clips to Velcro cable ties	05/06/10	EDG
C	Added coversheet	08/11/10	EDG