



# 161SES

## Durable Surface Mount Enclosure

### General Description

- Durable Enclosure Designed to Surface Mount VP161 Series Vandal-Proof Baffles
- Accommodates A Wide Variety of Loudspeaker / Transformer Configurations
- Heavy-Duty 18-Gauge Stainless Steel Construction Includes Undercoating and A White Powder Coat Finish
- Weather-Resistant and Suitable for Outdoor Use.

### Specifications

Height 11" (279mm)

Width 11" (279mm)

Depth 6" (152mm)

### Architect & Engineer Specifications

The surface mount metal protective enclosure shall be Atlas Sound Model 161SES or approved equal. Construction shall be 18-gauge stainless steel. Unit shall be equipped with four J-Nuts for installing screw-mount baffles and shall two combination 1/2"-3/4" (13mm - 19mm) conduit knockouts. Enclosure shall have a white epoxy finish and be undercoated to prevent acoustical and mechanical resonance. Unit shall be weather resistant and suitable for outdoor use. The enclosure shall mount Atlas Sound baffle Model VP161A or approved equal.



161SES

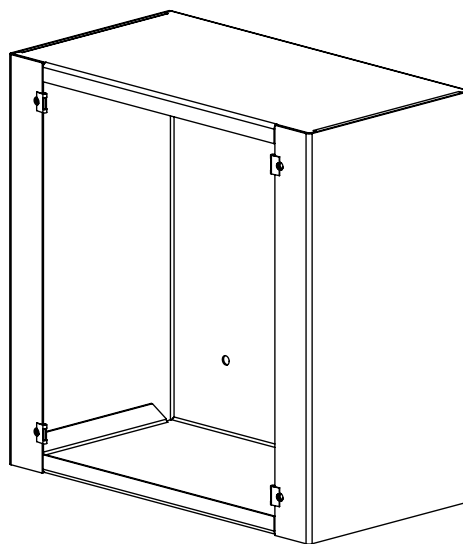
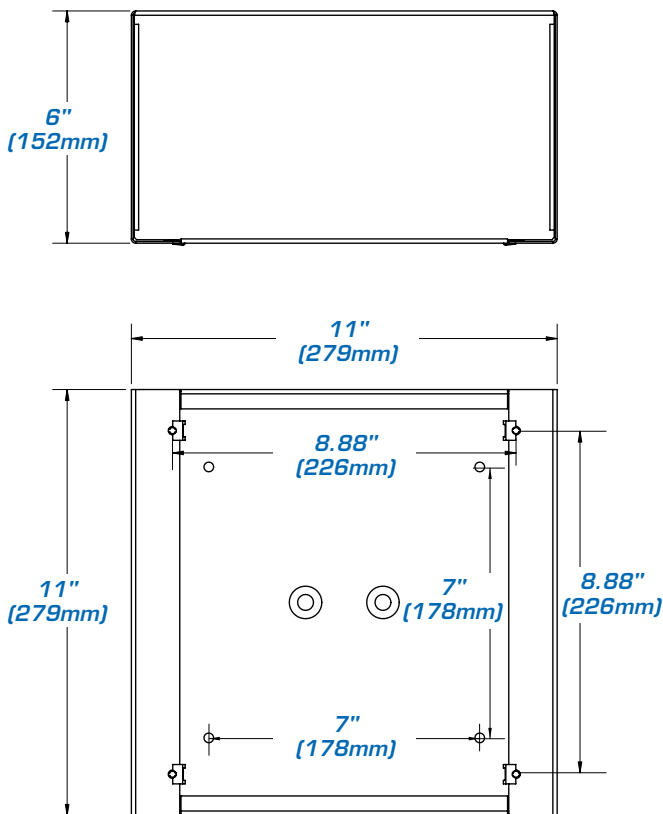

©2010 Atlas Sound L.P. All rights reserved. Atlas Sound and Strategy Series are trademarks of Atlas Sound L.P. All other trademarks are the property of their respective owners. ATSO03752 RevA 2/10