



General Description

The Rane AM 1 is part gain-sharing automatic mic mixer, part manual line mixer, part USB audio I/O device, and simultaneously a Rane RAD. Use it as a standalone mic/line mixer, add more gain-shared mics using up to seven Rane AM 2 Automixers (sold separately), and/or use the RAD Port to transport the main mix via a Rane Mongoose to a CobraNet network.

Each of the four XLR Mic Inputs offers front panel input Level controls feeding a gain-sharing automatic mixer. Rear panel, 3-position switches for each Mic Input support dynamic mics (no phantom power), condenser mics (48 V), or line input optimized for wireless receiver outputs (+10 dBu max). A front panel Mic Mix Level control adjusts the volume of all automixed mics.

The AM 1 is optimized for automixing speech. The mic inputs have a fixed 100 Hz to 7 kHz bandpass filter to provide the best voice-only automatic mixing using a gain-sharing algorithm.

Three manually-mixed audio inputs provide a simple user interface and installation. The Aux 1 Input dual RCA and Aux 2 3.5 mm jacks are independently monoed, each with a front panel Level control. A dedicated USB Charge port adjacent to Aux 2 provides power to USB devices such as iPods or other USB-powered devices. The separate orange USB Audio Input also offers a front panel Level control for the 16-bit, 48 kHz digital audio that is monoed immediately upon entry.

Signal and Overload indicators monitor the Mic and Aux Inputs, the Mic Mix and the Main Mix. Indicators flank the corresponding Level controls.

The AM 1 appears in Windows and Apple OS X computers as a standard USB Audio Device, immediately compatible with

dozens of audio recording and playback audio applications. The AM1 registers with the OS as a 16-bit 48 kHz device for both incoming and outgoing audio. The USB Audio port doubles as a firmware update port if future updates become available.

The XLR Main Output can be set to Mic- or Line-level to feed a mic snake or a +20 dBu max balanced input. The front panel Output Level control affects the XLR Output and the RAD Port output. The analog RECORD RCA Outputs and the digital USB Audio output are both mono, pre-Output Level, containing the same mix as the Main Output.

The RAD Port sends the AM 1 output mix to a Rane Mongoose for routing to output RADs and/or a CobraNet network. The Cascade IN accepts audio and data from a Rane AM 2's Cascade OUT. This adds the AM 2's eight mic channels to the AM 1, creating a 12 channel gain-sharing automix. Up to seven AM 2s can be cascaded to a single AM 1, offering up to 60 gain-shared mics. Both the RAD and the Cascade IN port have status indicators to aid setup and troubleshooting.

Rear panel Fault, Locate, USB and Power indicators inform head-scratchers of device errors, the AM 1's physical location, positive USB audio device OS registration and AC power status.

A front panel pre-Output Selector permits headphone cueing so users can verify input and output operation before bringing new sources into the live Output mix. Both 1/4" & 3.5 mm headphone jacks with a Level control are provided. Duplicate Locate and Power indicators are on the front and rear.

Universal IEC power on the rear supports 100 to 240 VAC and 50/60 Hz.

Rear Panel



Features and Specifications

XLR Inputs	Mono, Balanced, Mic/Line Selectable
Phantom Power	+48V per IEC 60268-15, Selectable in Mic mode
Maximum Input (Mic/Line)	-17 / +10 dBu
Input Impedance	2.01k, 1%
Input Gain Range (Mic/Line)	-80 to +34 dB / -80 to +26 dB
Frequency Response	100 Hz to 7 kHz, +0/-3 dB, -20 dBFS, Extended vocal range
Aux Inputs 1 / 2	Dual Mono, Unbalanced, RCA / 3.5 mm TRS
Maximum Input	+8 dBu
Input Impedance	18.8 kΩ, 1%
Gain Range	-80 to +12 dB
Frequency Response	20 Hz to 20 kHz, +0/-0.25 dB
Main Output	Mono, Balanced, XLR
Maximum Output (Mic/Line)	-20 / +20 dBu, 10 kΩ load
Output Impedance (Mic/Line)	51 / 300 Ω, 1%
Output Gain Range	-80 to 0 dB
Frequency Response	23 Hz to 20.5 kHz, +0/-3 dB
Dynamic Range (Line)	101 dB re +20 dBu, 20 kHz BW, A-weighted, 0 dB gain, 10 kΩ load
THD+N	< 0.01%, 22 Hz to 20 kHz, A-weighted, +4 dBu, 0 dB gain, 10 kΩ load
Record Output	Dual Mono, Unbalanced, RCA
Maximum Output	+12 dBu, 10 kΩ load
Output Impedance	602 Ω, 1%
Frequency Response	23 Hz to 20.5 kHz, +0/-3 dB
Dynamic Range	101 dB re +12 dBu, 20 kHz BW, A-weighted, 0 dB gain, 10 kΩ load
THD+N	< 0.01%, 22 Hz to 20 kHz, A-weighted, +4 dBu, 0 dB gain, 10 kΩ load
Headphone Output	Dual Mono, Unbalanced, ¼" and 3.5mm TRS
Maximum Output	+9 dBu, 150 Ω load
Maximum Output Power	30 mW into 150 Ω
Output Gain Range	-63 to +16 dB
Frequency Response	23 Hz to 20.5 kHz, +0/-3 dB
Dynamic Range	101 dB re +9 dBu, 20Hz to 20 kHz BW, A-weighted, 0 dB Gain, 150 Ω load
THD+N	< 0.06%, 22 Hz to 20 kHz, A-weighted, +4 dBu, 0 dB gain, 150 Ω load
LED Meters	Mono, peak detecting
Signal	-50 dBFS, Green LED, Peak-Reading
Overload	-0.5 dBFS, Red LED, Peak-Reading
RAD / Cascade In	8P8C (RJ-45) Connector
Sample Rate and Resolution	48 kHz @ 24 bits
USB Digital Audio	Dual Mono In/Out, USB-B connector
Sample Rate and Resolution	48 kHz @ 16 bits
USB Charge Only Port	USB-A Connector
Output Voltage and Current	+5 V max @ +500 mA max
Unit	All Steel Construction
Universal Line Voltage	100 to 240 VAC, 50/60 Hz, 13 W
Agency Listing	UL/cUL/CE
Size	1U 1.75"H x 19"W x 8.5"D (4.4 cm x 48.3 cm x 21.6 cm)
Weight	5 lb 4 oz (2.4 kg)
Shipping Size	4.5" x 20.3" x 13.75" (11.5 cm x 52 cm x 35 cm)
Shipping Weight	9 lb (4.1 kg)
<i>Note: 0 dBu = 0.775 Vrms</i>	

Block Diagram

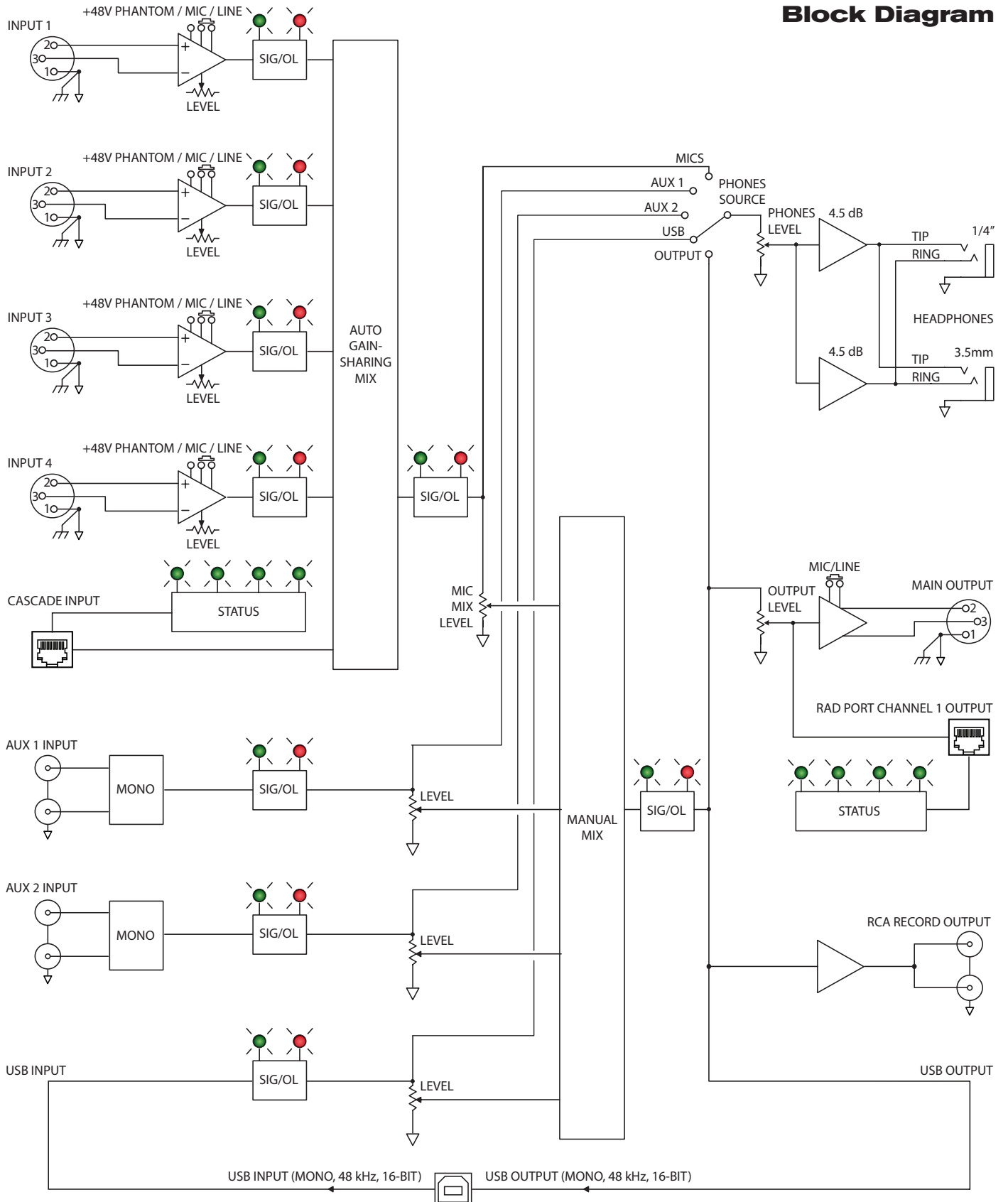

Applications

- AV Rental Systems
- Auditoriums
- Conference Centers
- Houses of Worship
- Hotels
- School AV Nerds
- Panel Discussions
- Podcasting

Facilities and rental agencies are called upon to provide either equipment, or equipment and operators, for meetings or conferences needing A/V support. The equipment providers must ensure audio quality throughout the event to get repeat business. However, the provided equipment may be operated by presenters who have no audio experience. If an operator is sent with the equipment to set up and manage the system during the presentation, that operator may have little audio experience. Pitfalls abound when interconnecting the system, and managing multi-microphone gain before feedback, mixing and volume. Handling iPod and laptop playback and/or recording adds even more complexity. Enter the Rane AM 1.

The AM 1 makes it easy for an inexperienced operator to quickly set up and manage audio for a multimedia presentation involving up to four participants with microphones (wired or wireless) and several program audio sources (e.g., DVD, Laptop, MP3 player).

The AM 1 offers a professional integrated solution that provides superior automatic gain before feedback while eliminating operator error with simple controls. The microphone gain-sharing algorithm automatically and appropriately attenuates mics not in use while maintaining the 3 dB per doubling of mics for different (noncoherent) talkers, and 6 dB per doubling for the same (coherent) talker who is directly between two mics. Appropriately, line audio sources are manually mixed since there is no acoustic feedback potential. The AM 1's flexible line input combination of RCA, 3.5 mm and separate USB Charge and Audio I/O ports makes integration and cabling easy. And since the USB Audio port can simultaneously playback audio and record the AM 1's output, the same laptop can be a source and a recording device to document AV meetings, presentations, trainings, and family karaoke nights for AV contractor employees.

Example AM 1 System

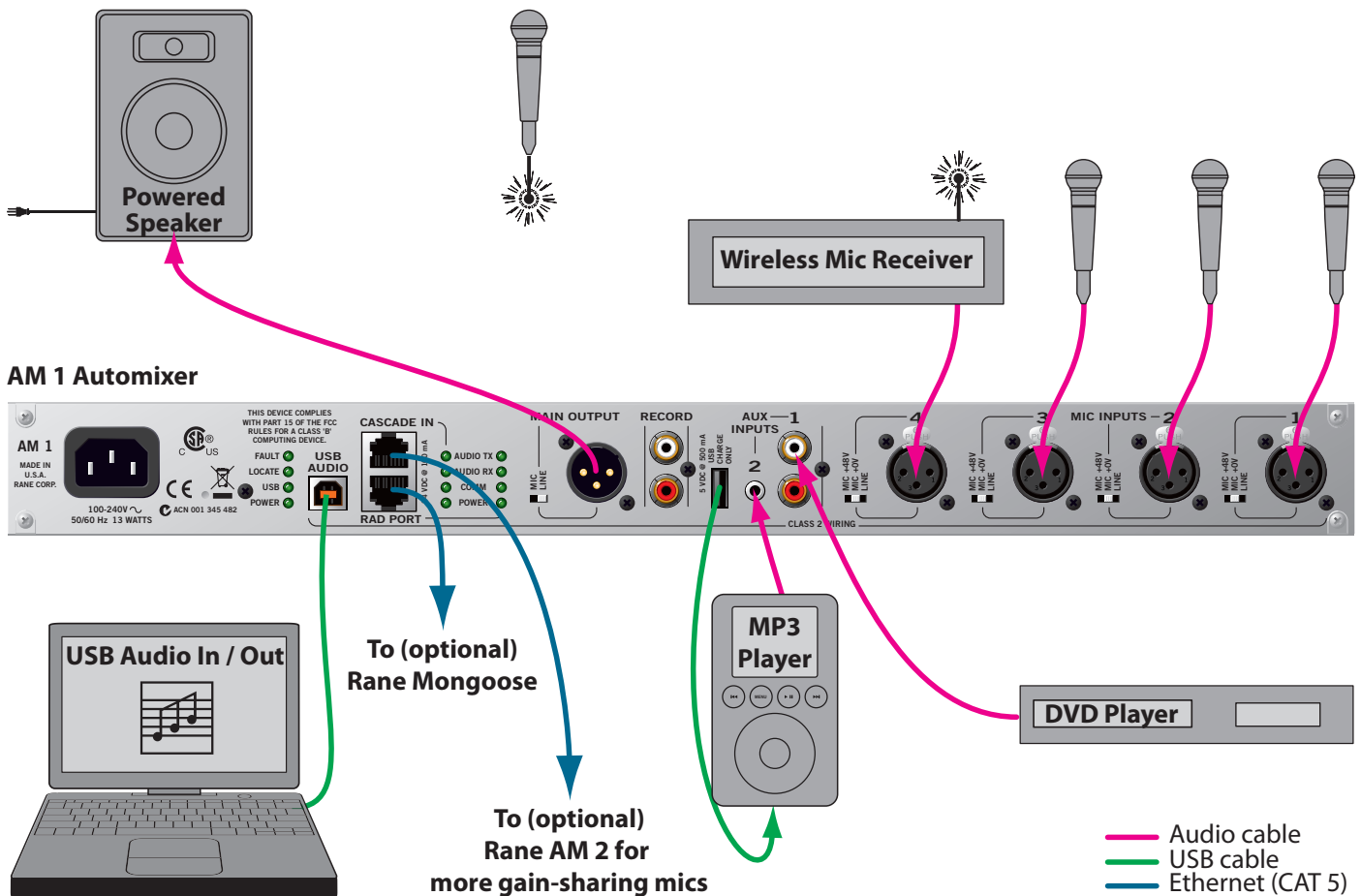

Features

INPUTS:

- Gain-Sharing Automatic Mic Mixing:
 - 4 XLR Inputs with Level controls & Sig/OL indicators.
 - Select Mic, Mic with 48V phantom, or Line level.
- Manually Mix:
 - Overall Mic Mix.
 - Two Aux Inputs: dual RCA & 3.5 mm, independently monoed.
 - USB Audio Input (16-bit, 48 kHz).
- USB Charge Port for iPod or other USB-powered devices.
- Power, Locate, USB, Fault, and RAD status indicators.

OUTPUTS (all mono):

- XLR Main with Mic/Line switch, Level control & Sig/OL.
- Dual RCA Record.
- Pre-Output Headphone ¼" and 3.5 mm with Level control:
 - Source select cues Mics, Aux 1, Aux 2, USB Input or Output.
- USB Audio Output (16-bit, 48 kHz).
- Rane RAD and Cascade IN RJ-45 Ports:
 - RAD Port sends Output to Mongoose for CobraNet transport.
 - Cascade IN port connects up to seven Rane AM 2 Automixers.

Architectural Specifications

The 1U audio device shall provide 4 rear-mounted XLR inputs automatically mixed using a gain-sharing algorithm. Each input shall permit independently selectable mic, mic with 48 volt phantom power, or line input level intended for wireless receiver output. Front panel mic input level controls for each input shall indicate signal and overload and an overall mic mix level control with signal and overload shall be provided.

Three manually-mixed inputs shall include dual RCA inputs, a 3.5 mm stereo jack and dedicated USB charge port, and an independent USB audio input; all three shall be monoed before mixing. Front panel mix level controls for all three inputs shall supply signal and overload indication.

Accommodation for two, post-level audio outputs shall be provided. One on a single XLR male balanced analog output with mic/line selector switch and the second via a Rane RAD Port on RJ-45 providing 24-bit, 48 kHz PCM digital audio transport to a CobraNet network via a Rane Mongoose. A mono, pre-output level mix shall be provided on dual-mono RCA jacks and via a USB Audio port providing 16-bit, 48 kHz PCM audio.

The USB Audio I/O port shall be recognized by Windows and Apple OS X devices as a standard USB audio device permitting simultaneous playback and recording to and from the device.

A cascade input RJ-45 shall permit gain-sharing mic mix expansion in groups of 8 channels from external automixer devices. Up to 60 gain-shared mics shall be supported.

A front panel pre-level selector shall provide headphone cueing with level control of either the mic mix, the RCA input, 3.5 mm input, the USB audio input, or the main output mix. Headphone outputs shall be provided on both ¼" and 3.5 mm jacks.

Universal 100 to 240 volt AC, 50 or 60 Hz operation shall be provided via an IEC rear panel plug.

The unit shall be a Rane AM 1.

The AM 1 and AM 2 RAD Ports are Mongoose-Compatible

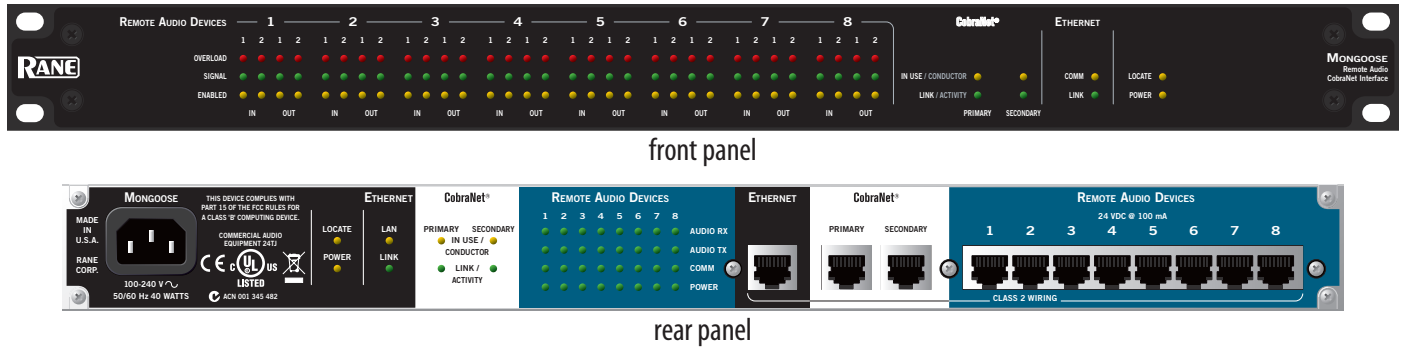

General Description

The Mongoose and its Tracker software work with Rane’s Remote Audio Devices (RADs) and your CobraNet network to deliver digital audio to the “last mile” of installations – between the equipment room/rack and remote spaces. OK, it’s not a mile, we lied: it’s actually 150 meters (492 feet to those in Liberia, Myanmar and the USA).

The Mongoose’s 32-by-32 digital audio matrix router receives its first 16 audio channels from up to eight RADs via the eight rear panel 8P8C (RJ-45) Remote Audio Device ports. The second 16 matrix input channels come from two eight-channel CobraNet receive (Rx) Bundles via standard CobraNet Primary and Secondary/backup ports. The 32 matrix router outputs transmit 16 channels to eight RADs and 16 more channels to two CobraNet transmit (Tx) Bundles.

A family of RAD models is shown to the right. Each converts analog audio to or from 24-bit, 48 kHz digital audio. Each RAD mounts in a standard US electrical gang box (except the RAD16), typically scattered throughout a facility. Standard CAT 5 cable and termination transport four digital audio channels – two channels in each direction – as well as power, ground and a communications channel via Rane’s proprietary RAD Network.

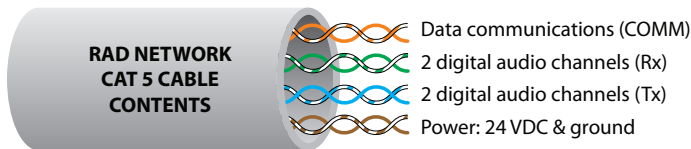

Mongoose’s rear panel Ethernet port provides for direct or network connection to a computer running Rane’s Mongoose Tracker software. Inexpert users are assured easy network communications with Zeroconf (Link-local/mDNS) and DHCP support. Gone are the days of installers requiring intricate IP knowledge. Yet, facility network managers can configure Mongoose like any other IP network device. The Ethernet port also supports Auto MDI/MDIX which automatically detects and permits either an Ethernet crossover cable (included) or a standard Ethernet cable to be used when directly connecting to a computer.

Features

- 32 by 32 digital audio matrix router.
- Receive 2 and transmit 2 CobraNet Bundles.
- Supports up to 32 digital audio channels from up to 8 RADs.
- Ethernet port supports DHCP, Zeroconf (Link-local & mDNS) & Auto MDI/MDIX.
- Mongoose Tracker setup software for PC is included.
 - Zeroconf-based Discovery automatically finds devices without IP setup or special IP knowledge.
 - Name each Mongoose, RAD and audio channel.

RAD Remote Audio Devices

