

# HP890i

## Open Ceiling Speaker

Preliminary Technical Information for System Engineers



**SOUNDTUBE**  
ENTERTAINMENT



### Specifications: HP890i

### Mounting hardware included

System Type	8" Coax, compression tweeter w/ 1" exit, open-ceiling, ported (120 Watt transformer for 25/70.7/100 Volt or voice coil / 8 Ohm direct)
Frequency Response (-3 dB) <sup>1</sup>	73 Hz - 22 kHz
Low Frequency (-10 dB) <sup>1</sup>	63 Hz - 22 kHz
Max. Program Power	250 Watts
Max. Continuous Power <sup>2</sup>	125 Watts
Max. SPL dB @ 1 M	115 dB
Sensitivity dB @ 1W/1M <sup>3</sup>	94 dB
Impedance (nominal)	8 Ohm
Coverage Angle (-6 dB @ 2Hz)	122°
Coverage Angle (-6 dB @ 4 kHz)	130°
Directivity Factor (Q)	4.64 (Averaged 100 Hz - 10 kHz); 4.48 @ 2 kHz
Directivity Index (DI)	8.34 dB (Averaged 100 Hz - 10 kHz); 6.51 dB @ 2 kHz
Tap Selector	5-Position rotary switch with voice coil direct (8 Ohm)

### Transformer Taps

70.7 V	Output	100 V	Output	25 V	Output
120 W	115 dB	120 W	115 dB	16 W	106 dB
64 W	112 dB	64 W	112 dB	8 W	103 dB
32 W	109 dB	32 W	109 dB	3.8 W	100 dB
16 W	106 dB	16 W	106 dB	1.9 W	97 dB

Transducers	
Low Frequency Driver	1 x 203 mm (8 in) Treated fiber cone, cloth surround
High Frequency Driver	1 Compression driver with waveguide and 25.4 mm (1 in) exit
Low Frequency Voice Coil	34 mm (1.36 in)
Crossover Frequency	2.4 kHz
Network Type	
Low Pass	12 dB per octave, 2nd order
High Pass	12 dB per octave, 2nd order
Enclosure Material	Injection molded ABS, glass fiber reinforced
Motor Board	Cast aluminum with integrated heat sink
Grille	Iridite-plated steel with powder-coat finish
Inputs	4 Pin, 5 mm Euroblock for individual or daisy chain connection
Colors	Black or white
Height	437.7 mm / 17.23 in
Diameter	376.5 mm / 14.82 in
Weight	10.0 kg / 22.1 lbs
Shipping Weight	N/A
Accessories	
Included	Hanging hardware, Euroblock connector & terminal weather boot
Optional	Surface-Mount Bracket (AC-RS-SM8)
Packaging	1 per box

<sup>1</sup> Frequency response is measured in full space.

<sup>2</sup> Continuous power rating, EIA-426-B test.

<sup>3</sup> 2.83 Volts at a distance of 1 meter.

SoundTube continually develops new product innovations and improvements. Updates to existing products without prior notice are an example of SoundTube's drive for constant improvement.

### Preliminary Technical Information

The information in this document reflects preliminary data. Items including polar plots, frequency, phase and impedance response graphs will be added when final data are available.

### Key Features

- BroadBeamHP<sup>®</sup> waveguide technology delivers a consistent dispersion pattern for maximum coverage area per speaker (up to 10 kHz, EASE<sup>™</sup> documented).
- One 203 mm (8.0 in) treated fiber driver and one compression driver with a 25.4 mm (1 in) exit mounted to a proprietary cast-aluminum M8<sup>™</sup> baffle and heat sink.
- 120 Watt transformer and high output (115 dB) for the sound reinforcement and PA markets.
- Easy-access 5-position selectable tap switch for 25, 70.7, and 100 Volt applications with voice coil/8 Ohm direct simplifies ordering and inventory tracking.
- Weatherized components for indoor/outdoor applications
- 94 dB Average sensitivity offers high-output capabilities and reduced amplification costs.
- Includes hanging hardware with aircraft cables and integrated SpeedClamp<sup>™</sup> self-locking wire grip for fast, easy & secure installation. Also includes Euroblock connector & terminal weather boot.
- Optional accessory: surface-mount bracket (AC-RS-SM8).
- High quality black or white paint finish.

### Description

The HP890i is a premium 8.0" 2-way, ported high-efficiency, high-SPL loudspeaker for distributed or 8 Ohm applications. The HP890i incorporates a dedicated 8.0" treated fiber driver and high-power compression transducer with a BroadBeamHP<sup>®</sup> waveguide to deliver a consistent dispersion pattern and superb intelligibility for the foreground music, sound reinforcement and PA markets. The HP890i incorporates a 120 Watt transformer with a 5-position tap switch and voice coil/8 Ohm direct position. Hanging hardware is included and features a fast-action SpeedClamp<sup>™</sup> for easy and secure installation.

### Applications

Engineered for installations requiring full-range background/foreground music plus paging, the HP890i delivers a smooth



### Frequency Response

**N/A**

and even coverage pattern. Ideal for warehouses, gyms, aerobic rooms, airports, super stores, arenas, theme parks, transportation and shipping centers, stadiums and other high-SPL or long-throw applications.

For professional sound reinforcement applications, indoors or out, the HP890i includes a cast-aluminum M8 motor-board, iridite-plated, powder-coated steel grille, durable enclosure design and terminal weather boot.

### BroadBeamHP® Wide Dispersion Technology

SoundTube's proprietary BroadBeamHP® technology incorporates a high-frequency compression driver with a 1" exit mated to a treated fiber woofer. The BroadBeamHP® technology delivers a 90° dispersion pattern across the upper registers of the frequency spectrum (up to 10 kHz, EASE™ documented). The result is an audio system with fewer speakers, reduced power needs, shorter installation time and cost savings on shipping and labor.

### Phase/Impedance Reponse

**N/A**

### Beamwidth (-6 dB)

**N/A**

### Directivity Index (DI)

**N/A**

---



## Patented SoundTube Technologies

SoundTube Entertainment is consistently developing new technologies that enhance audio product performance. SoundTube Entertainment innovations are protected by multiple U.S. and international patents, which explicitly cover SoundTube dome, enclosure, mounting and dispersion technologies. SoundTube Entertainment actively defends its patents in order to protect SoundTube resellers and end-users.

## Technical Data and Specification Tools

### Technical Data

SoundTube Entertainment strives to provide complete and effective technical information and data to dealers, engineers and designers. All data are available from SoundTube Entertainment or at [www.soundtube.com](http://www.soundtube.com).

### Data Acquisition

All performance data acquired at SoundTube's Technical Measurement Center (TMC) are analyzed using a vari-

ety of standard measurement techniques, including Measured Length Sequence (MLS) and Time Delay Spectrometry (TDS). Performance, development and data acquisition tools include: Gold Line TEF 20, CLIO, LMS, LEAP, and proprietary modeling software. EASE™ data are acquired through an automated TEF 20/Outline/EASE™ interface.

**EASE™ Data** – 3-D polar plots.

**SoundTubeSPEC™** – Proprietary SoundTube speaker placement software.

## Architectural Specifications

The loudspeaker shall consist of a 203 mm (8 in) low-frequency transducer and a high frequency transducer with a 1" exit and a frequency-dividing network installed in a ported enclosure. The low-frequency voice coil diameter shall be 34 mm (1.36 in).

The performance specifications of a typical production unit shall be as follows: Useable frequency response shall extend from 63 Hz – 22 kHz (-10 dB, no external equalization). Measured sensitivity (2.83 Volt input, 1 meter) shall be at least 94 dB. The speaker shall have a nominal

impedance of 8 Ohms and be available for 25/70.7/100 Volt modes with a voice coil/8 Ohm direct. The frequency-dividing network shall have a crossover frequency of 2.4 kHz with a slope of 12 dB per octave (2nd order). Rated power capacity shall be at least 125 Watts continuous power (RMS), and shall conform to EIA-426-B testing. Maximum continuous output at 1 meter shall be 115 dB.

The low-frequency transducer shall have a treated fiber cone and cloth surround.

Installation for the HP890i shall be by 10' aircraft cable affixed to the speaker chassis via hook. For seismic and safety redundancy, a secondary aircraft cable shall be included and shall attach to the speaker chassis via hook and cable system. The external wiring shall be a 4-pin 5 mm Euroblock connector for 8 Ohm or distributed systems and shall accept from 10 – 22 gauge wire. The system shall be for indoor and outdoor applications and have a weather-resistant terminal boot covering all wire connections.

The enclosure shall be constructed of injection-molded, glass reinforced ABS. The grille shall be constructed of iridite-plated, powder-coated steel for lasting performance

---

## Polar Plots

**N/A**



### Mechanical Drawings

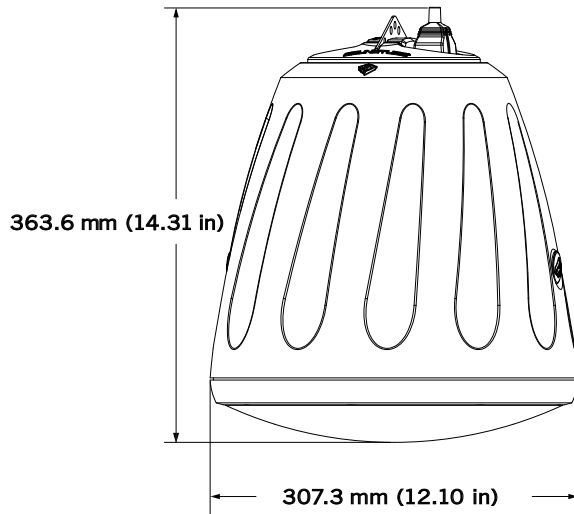

in the elements. Overall cabinet dimensions shall be no more than 437.7 mm (17.23 in) in height by 376.5 mm (14.82 in) in diameter and weigh no more than 10.0 kG (22.1 lbs).

The HP890i shall ship with hanging hardware, Euroblock connector and terminal weather boot. Optional accessories for the HP890i include surface-mount bracket (AC-RS-SM8), 20' hanging cable (AC-RS-HH-20) and 10' split loom tubing (AC-SLT-10) for architectural applications.

The system shall be the HP890i with hanging hardware for both low- and high-impedance applications.

### SoundTube Entertainment

6430 North Business Park Loop  
Park City, Utah 84098  
Phone 435.647.9555  
Fax 435.647.9666  
Toll Free 800.647.TUBE  
[www.soundtube.com](http://www.soundtube.com)

### Included Accessories

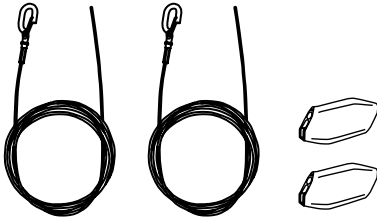

#### Hanging Hardware: Main & Safety Cables w/ SpeedClamp™

SoundTube's hanging cable kit incorporates hanging & safety cables & fasteners for an integrated and easy-to-install system. Hanging & safety cables are infinitely adjustable to 2.74 M (9.0 ft).

### Optional Accessory

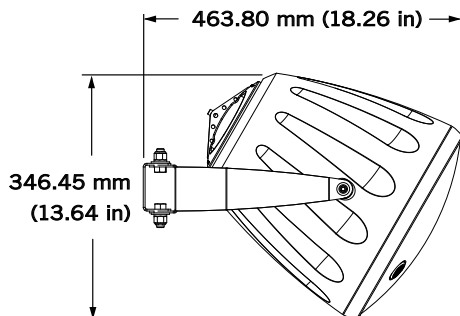

Surface-Mount Bracket (AC-RS-SM8)

SoundTube Entertainment manufactures a complete line of speakers for:  
**Open-Ceiling • In-Ceiling • Surface-Mount • Outdoor • Sound-Focusing**

All SoundTube products are designed and engineered in the USA.