

MAC III™ PROFILE

USER MANUAL



Martin®

Dimensions

All measurements are expressed in millimeters

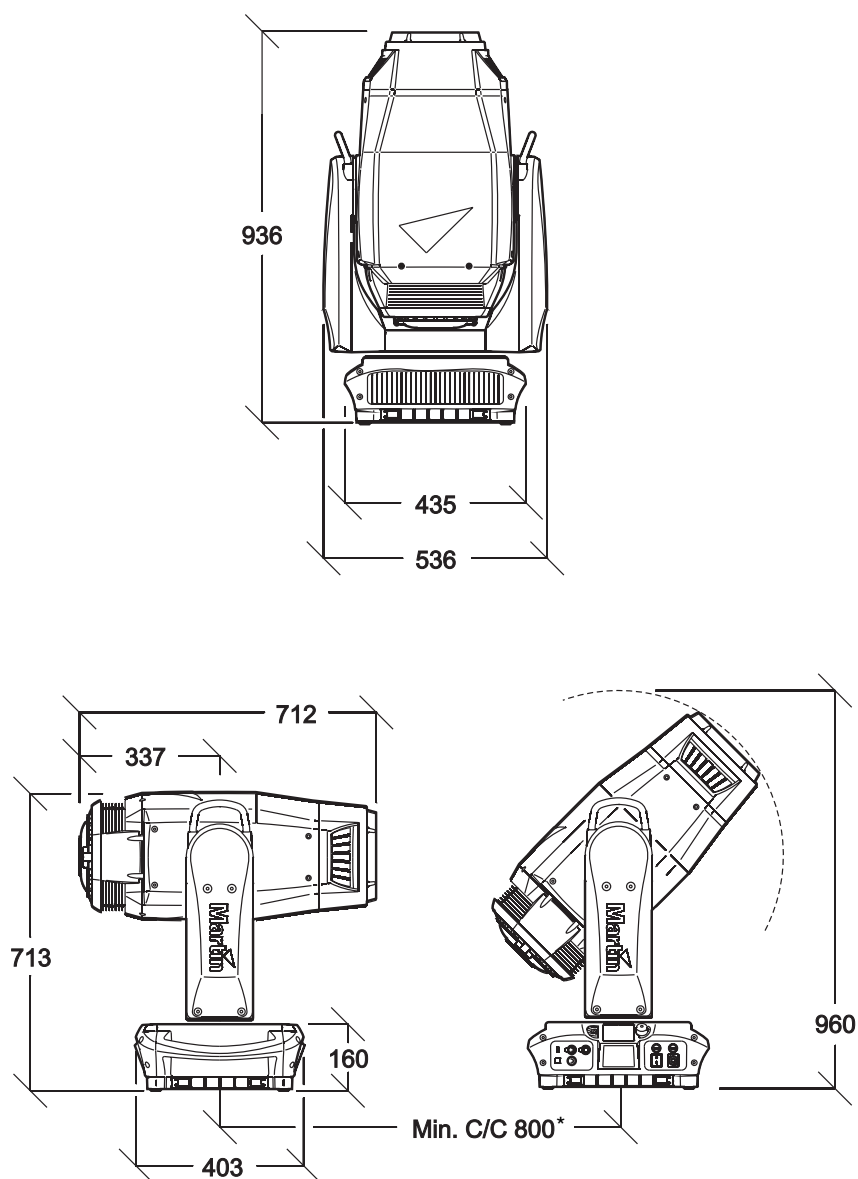

**The minimum center-to-center distance can be reduced if pan limits are set via the control menus*

© 2008-2009 Martin Professional A/S. Information subject to change without notice. Martin Professional A/S and all affiliated companies disclaim liability for any injury, damage, direct or indirect loss, consequential or economic loss or any other loss occasioned by the use of, inability to use or reliance on the information contained in this manual. The Martin logo, the Martin name and all other trademarks in this document pertaining to services or products by Martin Professional A/S or its affiliates and subsidiaries are trademarks owned or licensed by Martin Professional A/S or its affiliates or subsidiaries.

P/N 35000214, Rev. F

Contents

Safety Information	5
Introduction	7
Unpacking	7
Using for the first time	7
AC power	8
Power input and primary fuses	8
Power connection	8
Lamp	9
About the discharge lamp	9
Lamp replacement	9
DMX data link	11
Tips for reliable data transmission	11
Physical installation	12
Control panel operations	14
DMX address	15
DMX modes	16
Fixture ID	16
Personality – tailoring performance	16
Factory settings	19
Fixture information readouts	19
DMX signal monitoring	20
Test sequence	20
Manual control	20
Setup Wizard menu	20
Adjusting settings via DMX	21
Resetting	21
Lamp on / off	21
Adjusting lamp power	21
Illuminating the display	21
Control menu setting overrides	21
Effects	23
Shutter and strobe effects	23
Dimming	23
Cyan, Magenta, Yellow and CTO	23
Color wheel	23
Rotating gobos	23
Gobo animation	23
Beam effect (rotating prism)	24
Iris	24
Focus and zoom	24
Pan and tilt	24
Followspot	24
Optical configuration	26
Color wheel	26
Animation wheel	26
Gobos	27
Remote device management	28
RDM port	28
RDM ID	28
RDM communication	28
Service and maintenance	32
Tilt lock	32
Service utilities	32
Calibrating effects	33
Software installation	33

Cleaning	34
Lubrication	36
Replacing a color filter	36
Gobos in the MAC III Profile	37
Replacing the gobo animation wheel	40
Removing modules	41
MAC III Profile DMX protocol	42
Control panel menus	48
Service and display messages	52
Service warnings	52
Error messages	52
Troubleshooting	57
Specifications	58

Safety Information



WARNING!

Read the safety precautions in this section before installing, powering, operating or servicing this product.

The following symbols are used to identify important safety information on the product and in this manual:



DANGER!
Safety hazard.
Risk of severe injury or death.



DANGER!
Refer to manual before installing, powering or servicing.



DANGER!
Hazardous voltage. Risk of severe or lethal electric shock.



Warning!
Fire hazard.



Warning!
Burn hazard.
Hot surface. Do not touch.



Warning!
Risk of eye injury. Safety glasses must be worn.



Warning!
Risk of hand injury. Safety gloves must be worn.



This product is for professional use only. It is not for household use.

This product presents risks of severe injury or death due to fire and burn hazards, electric shock, lamp explosion and falls.



Read this manual before installing, powering or servicing the fixture, follow the safety precautions listed below and observe all warnings in this manual and printed on the fixture.

If you have questions about how to operate the fixture safely, please contact your Martin supplier or call the Martin 24-hour service hotline on +45 8740 0000, or in the USA on 1-888-tech-180.



PROTECTION FROM ELECTRIC SHOCK

- Disconnect the fixture from AC power before removing or installing any cover or part – including the lamp and fuses – and when not in use.
- Ensure that the fixture is electrically connected to ground (earth).
- Use only a source of AC power that complies with local building and electrical codes and has both overload and ground-fault (earth-fault) protection.
- Connect the fixture to AC power either using the supplied power cable or via 3-conductor cable that is rated minimum 20 amp, extra hard usage. Suitable cable types include ST, STW, SEO, SEOW and STO.
- Before using the fixture, check that all power distribution equipment and cables are in perfect condition and rated for the current requirements of all connected devices.
- Isolate the fixture from power immediately if the power cable or power plug are in any way damaged, defective or wet, or if they show signs of overheating.
- Do not expose the fixture to rain or moisture.
- Refer any service operation not described in this manual to an authorized Martin Service partner.



LAMP SAFETY

- Prolonged exposure to an unshielded discharge lamp can cause eye and skin burns. Do not stare directly into the light output. Never look at an exposed lamp while it is lit.
- Do not operate the fixture with missing or damaged covers, shields, lenses or ultraviolet screens.
- A hot discharge lamp is under pressure and can explode without warning. Allow the fixture to cool for at least 2 hours 45 minutes and protect yourself with safety glasses and gloves before handling a lamp or servicing the fixture internals.
- Replace the lamp immediately if it becomes visually deformed, damaged or in any way defective
- Monitor hours of lamp use and lamp intensity and replace the lamp when it reaches the limit of its service life as specified in this manual or by the lamp manufacturer.
- Install only an approved lamp.
- If the quartz envelope of a discharge lamp is broken, the lamp releases a small quantity of mercury and other toxic gases. If a discharge lamp explodes in a confined area, evacuate the area and ventilate it thoroughly. Wear nitrite gloves when handling a broken discharge lamp. Treat broken or used discharge lamps as hazardous waste and send to a specialist for disposal.



PROTECTION FROM BURNS AND FIRE

- The exterior of the fixture becomes very hot – up to 170° C (338° F) – during use. Avoid contact by persons and materials. Allow the fixture to cool for at least 2 hours 45 minutes before handling.
- Keep all combustible materials (e.g. fabric, wood, paper) at least 0.2 m (8 in.) away from the fixture. Keep flammable materials well away from the fixture.
- Provide a minimum clearance of 0.1 m (4 in.) around fans and air vents.
- Do not illuminate surfaces within 2.5 m (100 in.) of the fixture.
- Position or shade the head so that the lens does not face the sun at any time during daylight hours. The lens can focus the sun's rays inside the fixture, creating a potential fire hazard.
- Do not operate the fixture if the ambient temperature (Ta) exceeds 40° C (104° F).
- Do not modify the fixture in any way not described in this manual or install other than genuine Martin parts. Do not stick filters, masks or other materials onto any lens or other optical component. Use only Martin-approved accessories to mask or modify the light beam.
- Do not attempt to bypass a thermostatic switch or fuse. Replace defective fuses with ones of the specified type and rating only.



PROTECTION FROM INJURY DUE TO FALLS

- Do not lift or carry the fixture alone.
- Use two evenly spaced clamps to suspend the fixture from rigging structures. Do not use only one clamp.
- When clamping the fixture to a truss or other supporting structure at any other angle than with the yoke hanging vertically downwards, use two half-coupler clamps. Do not use G-clamps, quick-trigger clamps or any other type of clamp that does not completely encircle the supporting structure when fastened.
- When suspending the fixture, ensure that the supporting structure and all hardware used can hold at least 10 times the weight of all devices suspended from them.
- Do not use the handles in the base or the handles on the top of the yoke for hoisting or secondary attachment.
- Install as described in this manual a secondary attachment such as a safety cable that is approved by an official body such as TÜV as a safety attachment for the weight of all the fixtures it secures. The safety cable must comply with EN 60598-2-17 Section 17.6.6 and be capable of bearing a static suspended load ten times the weight of the fixture.
- Check that all external covers and rigging hardware are securely fastened.
- Block access below the work area and work from a stable platform whenever installing, servicing or moving the fixture.

Introduction

Thank you for selecting the Martin™ MAC III Profile™. This moving-head spotlight features:

- 1500 Watt short-arc high-output Osram HTI 1500W/60/P50 discharge lamp with semi-hot restrike
- Backlit graphic display and battery power (mains power not required for fixture setup)
- Full-range mechanical dimmer with four dimming curve options, plus mechanical shutter
- Full-spectrum CMY color mixing and CTO color temperature control
- 7 interchangeable dichroic color filters
- Two gobo wheels, each with 5 interchangeable rotating gobos with 16-bit position indexing
- Interchangeable gobo animation wheel
- Interchangeable four-facet rotating prism
- Iris
- Variable focus and zoom with 3-zone zoom/focus linking system
- 540° of pan and 268° of tilt with user-settable pan/tilt limits
- Electronic “flicker-free” ballast and auto-sensing switch-mode power supply.

For the latest firmware updates, documentation, and other information about this and all Martin Professional products, please visit the Martin website at <http://www.martin.com>

Comments or suggestions regarding this document may be e-mailed to service@martin.dk or posted to:

Service Department
Martin Professional A/S
Olof Palmes Allé 18
DK-8200 Aarhus N
Denmark

Unpacking

The MAC III Profile is packaged in either a cardboard box or a flightcase that is designed to protect the product during shipment. The following items are included:

- 1500 W discharge lamp (installed)
- Two 16 AT fuses (installed)
- 2 omega brackets for clamp attachment
- This user manual

Using for the first time

Before applying power to the fixture:

- Carefully review the safety information starting on page 5.
- Check that the fuses in the Live and Neutral fuseholders near the main on/off switch match the local AC power voltage as described in “Power input and primary fuses” on page 8.
- If necessary, install a cord cap (mains plug) on the power cable as described in “Power connection” on page 8.
- Unlock the tilt lock as described on page 32.
- Check that the base is fastened securely so that the torque reaction when the head is panned does not cause the fixture to move.

When powered up, check lamp alignment as described on page 10.

AC power



Warning! For protection from electric shock, the fixture must be grounded (earthed). The AC mains supply must be fitted with a fuse or circuit breaker and ground-fault (earth-fault) protection.



Important! Check that the correct fuse is installed before applying power.



Power input and primary fuses

The MAC III Profile features an auto-sensing switch-mode power supply that automatically adapts to 200-240 V (nominal) AC power at 50 or 60 Hz. It is protected by two 16 A slow-blow primary fuses, one for the live conductor and one for the neutral conductor.

To install fuses:

1. Disconnect the fixture from AC power.
2. Use a flat-headed screwdriver to open the two main fuseholders, located above the power on/off switch and mains input socket.
3. Install one 16 AT fuse in each fuseholder.
4. Reinstall the fuseholders before reapplying power.

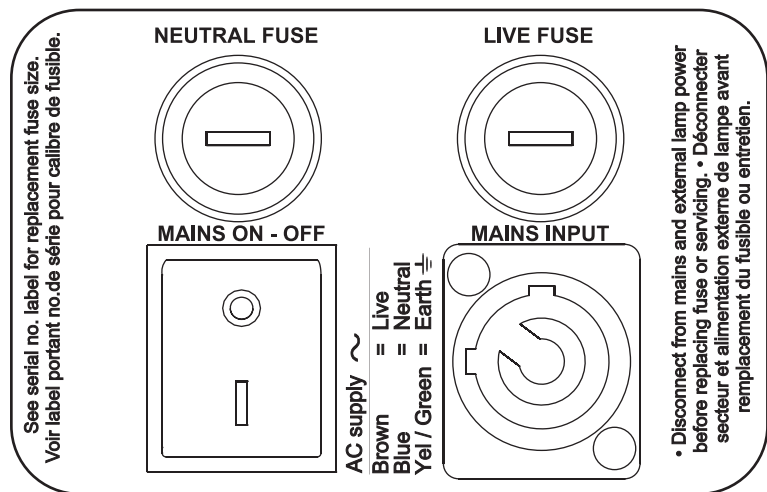

Power connection

Important! Connect the MAC III Profile directly to AC power. Do not connect it to a dimmer system; doing so may damage the fixture.

If you install a cord cap (mains plug) on the power cable to allow connection to power outlets, install a grounding-type (earthed) plug, following the plug manufacturer's instructions. Table 1 shows some possible mains power pin identification schemes; if the pins are not clearly identified, or if you have any doubts about proper installation, consult a qualified electrician.

To apply power, first check that the head tilt locks are released and then set the power switch on the base to the "I" position.

Wire Color	Pin	Symbol	Screw (US)
brown	live	L	yellow or brass
blue	neutral	N	silver
yellow/green	ground (earth)		green

Table 1: Cord cap connections

The MAC III Profile is supplied with a power cable with a Neutrik PowerCon NAC3FCA cable connector for power input. If you replace the power cable, observe the pinout marked on this cable connector. Connect the terminal marked to ground (earth), the terminal marked N to neutral, and the terminal marked L to live. Replacement power cable must be 3-conductor, rated minimum 20 amp, extra-hard usage. Suitable cable types include ST, STW, SEO, SEOW and STO.

Lamp

About the discharge lamp

The MAC III Profile is designed for use with an Osram HTI 1500W/60/P50 lamp. This highly efficient double-ended short-arc source provides a color temperature of 6000 K, a color rendering index greater than 85, an average service life of 750 hours and semi-hot restrike, meaning that a hot lamp is ready to strike again after 90 seconds.

Lamp power is automatically reduced to approximately 800 W after 10 seconds when the fixture is blacked out in order to reduce cooling fan activity and power consumption. The lamp returns to 1500 W as soon as the dimmer and/or shutter are opened.

Warning! *Installing any other lamp may create a safety hazard or damage the fixture!*

To reduce the risk of explosion, replace the lamp when it reaches the limit of its average service life, i.e. when usage reaches 750 hours. Never exceed the lamp's average service life by more than 10%. To read lamp hours in the fixture's display, refer to the section on lamp hours readouts on page 19. Replace the lamp immediately if it is deformed or in any way defective.

For maximum service life, avoid powering the lamp off until it has warmed up for at least 5 minutes.

Lamp replacement



Warning! *Wear safety glasses and gloves when handling lamps. The clear lamp bulb is integral with the ceramic lamp base. Do not try to separate the bulb from the base.*



Important! *The lamp can be a stiff fit in its holder. Twist the lamp base a full 45° clockwise when installing to ensure that the lamp contacts are fully engaged.*

Replacement lamps are available from your Martin dealer requesting P/N 97010326.

The clear bulb must be perfectly clean. Do not touch it with your fingers. Clean the lamp with an alcohol wipe and polish it with a dry cloth before installing, particularly if you accidentally touch the bulb.

To replace the lamp:

1. Disconnect the fixture from power and allow it to cool for at least 2 hours 45 minutes.
2. Lock the head.
3. Release the screw on the lamp access cover and open the cover.
4. Grasp the ceramic lamp base, twist it 45° counterclockwise and withdraw the lamp from the fixture as shown in Figure 2.
5. The lamp base has two metal contacts, one narrow and one wide, that fit into corresponding narrow and wide slots in the lampholder. Line up the contacts on the replacement lamp's base with the corresponding slots in the lampholder, slide the lamp into the fixture so that the contacts are fully engaged in the slots, and then twist the lamp base a full 45° clockwise until it locks into position with a noticeable click. The lamp is a stiff fit and trying to strike a lamp that is not correctly installed can cause damage that is not covered by the product warranty, so ensure that the lamp is correctly locked into position.
6. Close the lamp access cover and tighten the screw to secure the cover before reapplying power.
7. After installing a new lamp, reset the lamp hour counter (see the section on lamp hours readouts on page 19).

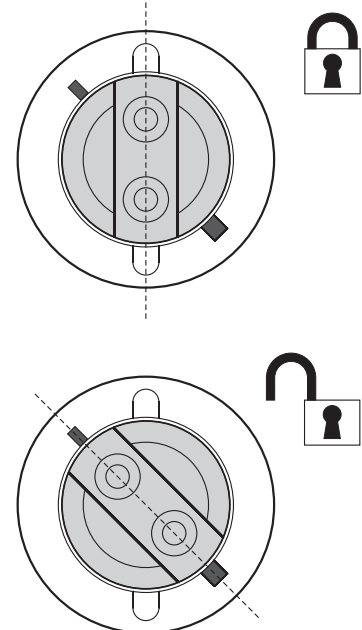

Figure 2: Lamp removal / refitting

Lamp adjustment



Warning! Adjust the lamp with the fixture cool. The fixture may become hot during adjustment, so wear heat-resistant safety gloves.



As well as being undesirable for aesthetic reasons, a significant hot-spot in the beam will focus extra heat onto optical components and may cause damage that is not covered by the product warranty.

After fitting a new lamp, adjustment may be required to obtain an even beam.

To adjust the lamp:

1. If the fixture has been in use, allow it to cool for at least 2 hours 45 minutes to avoid the danger of burns, and wear heat-resistant safety gloves.
2. Apply power, allow the fixture to reset, then set zoom to narrow, turn on the lamp and open the mechanical shutter.
3. Aim the fixture at an even surface and make sure no further commands can be sent by DMX.
4. See Figure 3. Screw the three lamp adjustment screws in or out to obtain the most even beam.

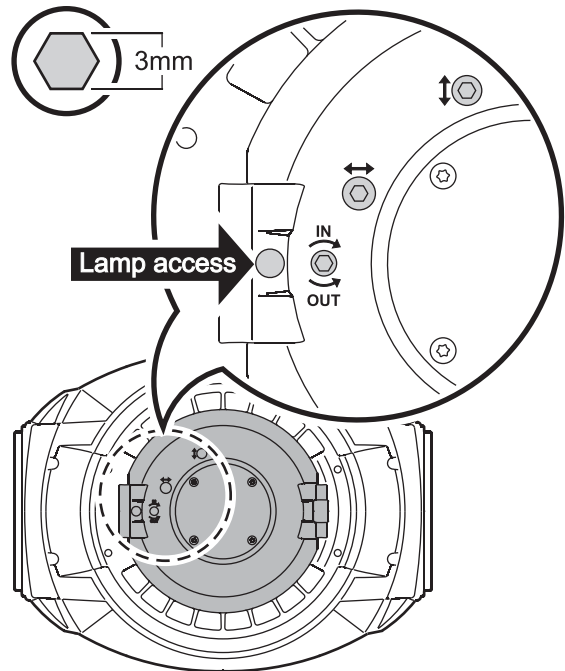

Figure 3: Lamp adjustment screws

DMX data link

The MAC III Profile has 5-pin locking XLR sockets for DMX and RDM input and output. The default pin-out on both sockets is:

- pin 1 to shield

Port 1, DMX and RDM communication:

- pin 2 to data 1 cold (-)
- pin 3 to data 1 hot (+)

Port 2, not used by default but available for data communication:

- pin 4 to data 2 cold (-)
- pin 5 to data 2 hot (+).

The default use of Port 1 for DMX and RDM can be altered in the control panel (see “Personality – tailoring performance” on page 16).

Tips for reliable data transmission

- Use shielded twisted-pair cable designed for RS-485 devices: standard microphone cable cannot transmit control data reliably over long runs. 24 AWG cable is suitable for runs up to 300 meters (1000 ft). Heavier gauge cable and/or an amplifier is recommended for longer runs.
- To split the serial link into branches, use a splitter such as the Martin 4-Channel Opto-Isolated RS-485 Splitter/Amplifier.
- Do not overload the link. Up to 32 devices may be connected on a serial link.
- Install a DMX termination plug on the last fixture on the link.

To connect the data link

1. Connect the DMX data output from the controller to the MAC III Profile’s data input (male XLR) socket.
2. Run the data link from the MAC III Profile’s data output (female XLR) socket to the data input of the next fixture.
3. Terminate the data link by connecting a 120 Ohm, 0.25 Watt resistor between the data 1 hot (+) and cold (-) conductors (and between data 2 hot and cold if used) at the data output of the last fixture on the link. If a splitter is used, terminate each branch of the link.

Physical installation



Warning! The MAC III Profile has a powerful pan motor. The torque reaction when the head is panned suddenly can cause the base to move if the fixture is standing unsecured on a surface. Do not apply power to the MAC III Profile unless the base is securely fastened to a surface or to rigging hardware.

Warning! Use 2 clamps to rig the fixture. Do not hang the fixture from only one clamp. Lock each clamp with both 1/4-turn fasteners. Fasteners are locked only when turned fully clockwise.

Warning! When suspending the fixture above ground level, secure it against failure of primary attachments by attaching a safety wire that is approved as a safety attachment for the weight of the fixture to the attachment point in the base. Do not use the carrying handles for secondary attachment.

Warning! When clamping the fixture to a truss or other structure at any other angle than with the yoke hanging vertically downwards, use two clamps of half-coupler type. Do not use any type of clamp that does not completely encircle the structure when fastened.



Warning! Position or shade the head so that the lens does not face the sun at any time during daylight hours. The MAC III Profile's lens can focus the sun's rays inside the fixture, creating a potential fire hazard and causing internal damage.

Important! Do not point the output from other lighting fixtures at the MAC III Profile from a distance of less than 3 m (10 ft.), as intense illumination can damage the display.

The MAC III Profile can be fastened to a surface such as a stage or clamped to a truss in any orientation. Clamps must be half-coupler type (see Figure 5) unless the fixture is installed with the yoke hanging vertically downwards. The mounting points allow the clamp brackets to be fastened parallel, perpendicular or at 45° to the front, as shown Figure 4.

Pan and tilt range can be limited via the control panel to allow fixtures to be installed close to each other or to obstacles with no risk of collision (see **PAN/TILT SETTINGS** on page 16).

Clamping the fixture on a truss

1. Check that the rigging clamps are undamaged and can bear at least 10 times the weight of the fixture. Check that the structure can bear at least 10 times the weight of all installed fixtures, clamps, cables, auxiliary equipment, etc.
2. Bolt each clamp securely to a clamp bracket with an M12 bolt (minimum grade 8.8) and lock nut.

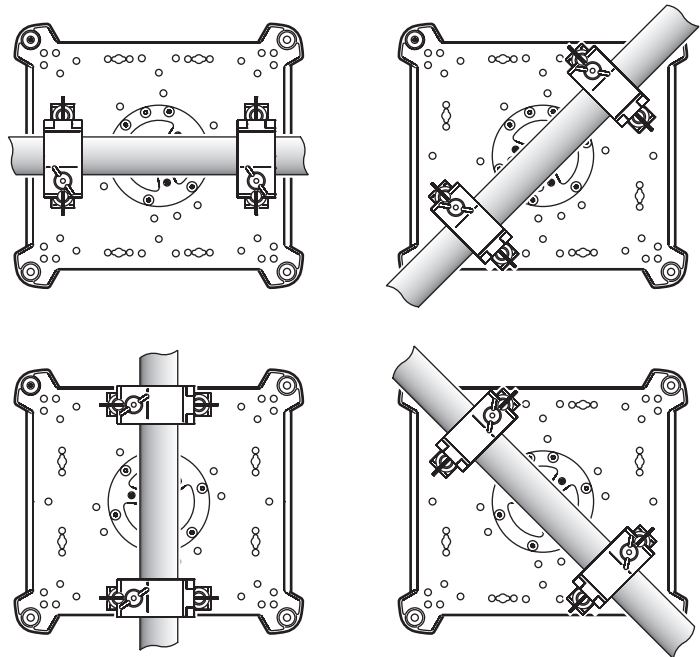

Figure 4: Clamp bracket positions



Figure 5: Martin half-coupler clamp

- See Figure 6. Note the position of the arrows on the bottom of the base that indicate the front of the fixture.

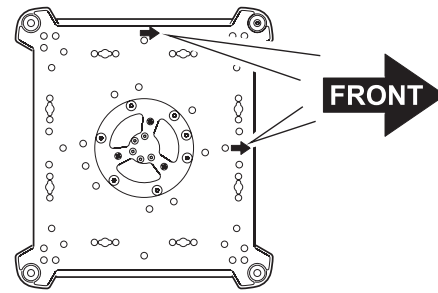

Figure 6: Front of fixture

- Align a clamp with 2 mounting points in the base. See Figure 7. Insert the fasteners into the base and turn both levers a full 1/4-turn clockwise to lock. Install the second clamp.
- Block access under the work area. Working from a stable platform, hang the fixture on the truss with the arrows marked **FRONT** printed on the base of the fixture facing towards the area to be illuminated. Tighten the rigging clamps.

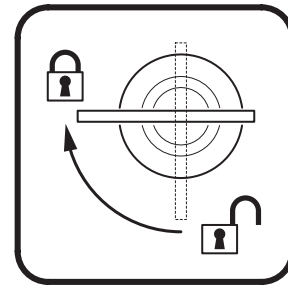

Figure 7: Locking 1/4-turn fasteners

- See Figure 8. Install a safety wire that is approved as a safety attachment for the weight of the fixture by looping it through the safety attachment wheel on the bottom of the base.
- Check that the tilt lock is released. Check that there are no combustible materials within 0.2 m (8 in.) or surfaces to be illuminated within 2.5 m (100 in.) of the fixture, and that there are no flammable materials nearby.
- Check that there is no possibility of heads or yokes colliding with other fixtures. Note that pan and tilt range on the MAC III Profile can be restricted by setting minimum and maximum limits via the control menus. This feature allows fixtures to be installed closer together or closer to obstacles.
- Check that other lighting fixtures cannot project light at the MAC III Profile from a distance of less than 3 m (10 ft.), as intense illumination can damage the MAC III Profile's display.

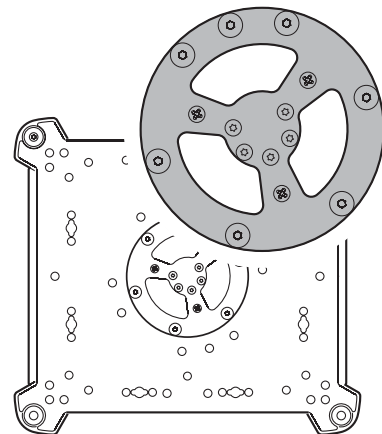

Figure 8: Safety cable attachment point

Control panel operations

You can configure individual fixture settings such as the MAC III Profile's DMX address, read out data and execute service using the fixture's backlit graphic display and control panel. The control menu overview starting on page 48 gives a complete list in table form of the menus and commands available.

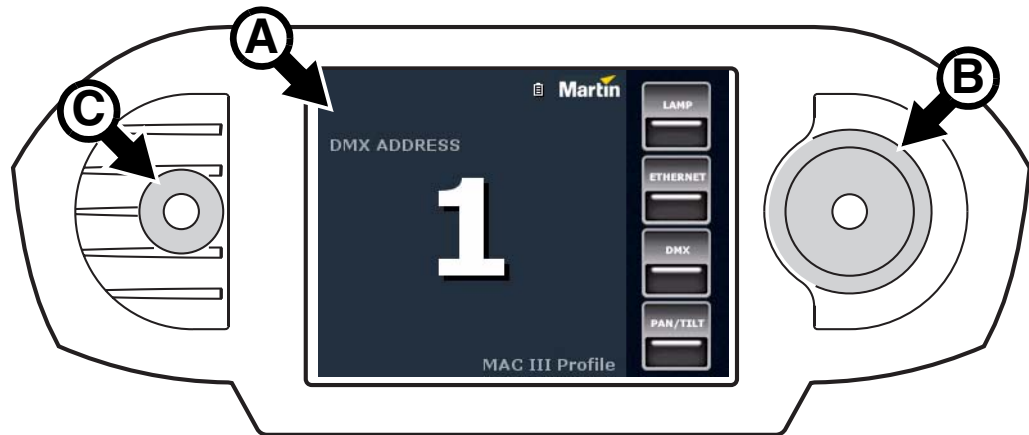

Figure 9: Display and control panel

After a pause while the fixture boots and resets, the DMX address and any status messages (see page 52) appear in the graphic display **A** when the MAC III Profile is powered on.

Using the control panel

Click (i.e. press once) the jog wheel **B** once to enter the menus. Rotate the jog wheel to scroll up and down menus and click the jog wheel once to make a selection. Rotating the jog wheel faster gives high-speed scrolling.

Once you have made a selection, either click the jog wheel to save it or press the Escape button **C** to cancel. If you save the selection, **Saving...** is displayed for 1 second. If you cancel, the menu returns to the previously saved value. Press the Escape button to step backwards through the menus.

The jog wheel and Escape button continue to function while the **Saving...** message is displayed.

Status LED on jog wheel

An LED in the center of the jog wheel indicates fixture status depending on the color displayed and DMX status depending on whether the LED flashes or lights constantly:

- **GREEN:** All fixture parameters normal.
- **AMBER:** Warning active (service interval exceeded, for example). If **ERROR MODE** is set to **Normal**, the warning message will be shown in display. If **ERROR MODE** is set to **Silent**, the display must be activated with the jog wheel to display the warning message.
- **RED:** Error detected. If **ERROR MODE** is set to **Normal**, the error message will be shown in display. If **ERROR MODE** is set to **Silent**, the display must be activated with the jog wheel to display the error message.
- **FLASHING:** No DMX signal detected.
- **LIGHTS CONSTANTLY:** Valid DMX signal detected.

If an error has been detected and the LED is red when the fixture is powered off, the LED will continue to flash red slowly. This feature allows easy identification of fixtures that require service intervention even if fixtures are disconnected from power.

Martin flightcases for the MAC III Profile contain a small window through which the status LED is visible.

Battery power

The display and control panel are powered by the MAC III Profile's onboard battery. This gives access to the most important functions in the control panel – including DMX addressing – when the fixture is not connected to AC power.

To activate the display when the fixture is not connected to power, press the Escape button. The display extinguishes after 10 seconds with no jog wheel activity and the control panel is de-activated after 1 minute with no jog wheel activity. Press the Escape button again to re-activate.

A battery icon in the display shows battery charging status.

Mains power indicator

A mains plug icon appears in the display when the fixture is connected to AC mains power.

Status indicators in display

The status indicators on the right of the display have the following functions:

- **LAMP** lights when the lamp is powered.
- **ETHERNET** lights when the MAC III Profile is correctly connected to an Ethernet network.
- **DMX** lights when the MAC III Profile is receiving a valid DMX signal.
- **PAN/TILT** lights when pan/tilt limits have been activated (see page 16).

Shortcuts pop-up

If you hold the Escape button pressed in for 2 - 3 seconds, a pop-up window with shortcuts to 3 important commands appears. Select a command and click the jog wheel to activate, or press Escape to cancel.

- **RESET** resets the whole fixture
- **LAMP ON/OFF** strikes or douses the lamp.
- **ROTATE DISPLAY** rotates the MAC III Profile display.

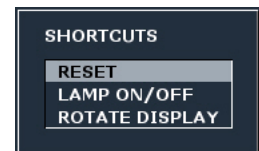

Settings stored permanently

The following settings are stored permanently in the fixture memory and are not affected by powering the MAC III Profile off and on or by updating the fixture software:

- DMX address
- DMX Protocol setting
- Fixture ID
- All personality settings (pan/tilt and pan/tilt limit, linked zoom/focus, lamp cooling, fan clean mode, dimming curve, DMX lamp off, DMX reset, parameter shortcuts, all display settings, error mode)
- Factory settings
- Fixture info (resettable power-on, lamp-on, lamp strikes, and air filter counters)
- All Service settings (adjust, calibration, firmware)

These settings can be returned to factory defaults using the control menus or via DMX.

DMX address

The DMX address, also known as the start channel, is the first channel used to receive instructions from the controller. For independent control, each fixture must be assigned its own control channels. If you give two MAC III Profiles the same address, they will behave identically. Address sharing can be useful for diagnostic purposes and symmetrical control, particularly when combined with the inverse pan and tilt options.

DMX addressing is limited to channels 1 - 486 in 16-bit mode and 1 - 483 in 16-bit extended mode. The upper limit makes it impossible to set the DMX address so high that you are left without enough control channels for the fixture.

DMX address setting

To set the fixture's DMX address:

1. Press the jog wheel to enter the main menu.
2. Rotate the jog wheel to scroll down to **DMX ADDRESS**, then click the jog button. Rotate the jog wheel to scroll to the desired address and click the jog button to save.
3. Press the Escape button to step back to the main menu.



DMX modes

The **PROTOCOL SET** menu lets you set the MAC III Profile to one of the two DMX operating modes, 16-bit and 16-bit extended.

The basic 16-bit mode offers coarse control of all effects plus fine control of gobo indexing angle on both gobo wheels, pan and tilt. The 16-bit extended mode requires three more DMX channels than the basic 16-bit mode and provides all features of the basic 16-bit mode plus fine control of the dimmer, zoom and focus.

The MAC III Profile requires 27 DMX channels in 16-bit mode and 30 DMX channels in 16-bit extended mode.

DMX mode setting

To set the fixture's DMX mode:

1. Click the jog wheel to enter the main menu.
2. Rotate the jog wheel to scroll down to **PROTOCOL SET**, then click the jog wheel. Rotate the jog wheel to select either **16 bit** or **16 Bit Ext.**, then click the jog wheel to save.
3. Press the Escape button to step back to the main menu.



Fixture ID

The MAC III Profile lets you set a four-digit ID number to ease identification of the fixtures in an installation. When a fixture is powered on for the first time, it displays its DMX address by default. As soon as you set an ID number other than **0000** in **FIXTURE ID**, the MAC III Profile will display this ID number by default.

To let you distinguish easily between ID numbers and DMX addresses, the ID number is always displayed with four digits and DMX address is displayed with between one and three digits.

Personality – tailoring performance

The MAC III Profile provides several options that let you optimize the fixture for different applications in the **PERSONALITY** menu:

- The **PAN/TILT SETTINGS** menu gives three options:
 - **PAN/TILT CONTROL** lets you swap and/or invert pan and tilt and activate the pan and tilt limits you define in **PAN & TILT LIMIT SETTINGS** (see below).
 - **MOVE ON RESET** lets you choose if you want pan and tilt to move when the fixture resets or not. Pan and tilt movement can be a useful visual sign that fixtures in a rig are powering up and resetting.
 - **PAN & TILT LIMIT SETTINGS** lets you define minimum and maximum limits for both pan and tilt angles, making it possible to install fixtures close to obstacles such as other fixtures with no risk of collision. Settings are based on the following principles:

Pan range for pan limit purposes runs from 0° to 360° clockwise as seen looking at the fixture from the bottom of the base towards the yoke, as if the fixture was hanging downwards underneath you.



Tilt range is +134° and -134° either side of 0°, which is the head straight up position with the front glass pointed directly away from the base.

The light beam points fully forward (the front of the fixture is indicated by the arrows printed under the base) when pan is set to 90° or 450° and tilt is set to +90°.

Selecting **Inside** keeps pan and tilt inside the limits you set – i.e. angles define a 'safe zone'.

Selecting **Outside** keeps pan and tilt outside the limits you set – i.e. angles define a 'no-go zone'.

Limits are not activated until the head is panned and tilted into its safe zone or out of its no-go zone.

When pan/tilt limits are active, the PAN/TILT light at the bottom right of the display lights yellow.

See Figure 10. To limit pan so that it stays inside a safe zone 20° either side of fully forward and limit tilt so that it stays inside a safe zone 18° either side of fully forward, for example:

1. Set **PAN MINIMUM** to 70°.
2. Set **PAN MAXIMUM** to 110°.
3. Set **TILT MINIMUM** to +72°.
4. Set **TILT MAXIMUM** to +108°.
5. Set **P/T LIMIT AREA** to **Inside**.

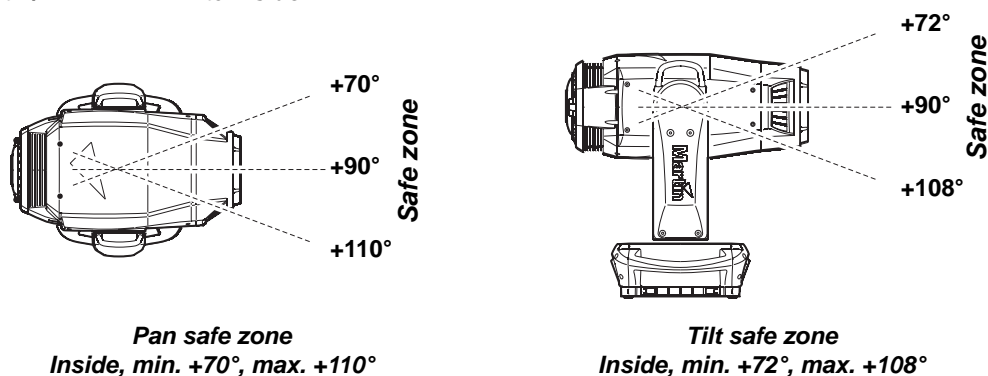

Figure 10: Pan/Tilt limit settings

Important! *Regardless of the pan and tilt limits you set, when you power the fixture off, the head will sink under gravity to the nearest rest position (e.g. with the lens pointing vertically downwards if the fixture is hanging in a rig, or to one side if the fixture is standing fastened to a horizontal surface). When you power the fixture on, the head will not move until the fixture receives a pan or tilt command. When a command is received, if the head's rest position is outside its pan/tilt limits, the head will move slowly until it is within its limits. This feature reduces the risk of damage caused by a collision.*

Pan and tilt limits can quickly be returned to the factory default setting (all limits at 0°, pan/tilt limits disabled) by setting **DEFAULT LIMIT SETTINGS** to **On** and clicking with the jog wheel to confirm.

- **SPEED SETTINGS** lets you set **PAN & TILT SPEED** to **Normal**, **Fast** (optimized for speed) or **Slow** (optimized for smooth movement – useful in long-throw applications). Likewise, you can set **EFFECT SPEED** to **Normal**, **Fast** or **Slow**. You can also set effect speed to **Follow P/T speed**, in which effects will always use whatever speed is set for pan and tilt.
- The **FANS** menu gives three cooling fan options:
 - **LAMP COOLING** sets the lamp cooling effect to 50% or 80%. The color temperature of the lamp and lamp performance towards the end of the lamp life vary slightly with the level of lamp cooling applied. The default level is 80%, which is recommended for optimum performance over the full life of the lamp. Setting to 50% gives a slightly lower color temperature and quieter fan operation but accelerates the gradual reduction in output which is normal over the lifetime of a discharge lamp.
 - **FAN CLEAN** gives three options for automatically clearing dirt from fans:
 - Off** sets fans to normal operation with no fan cleaning function.
 - Auto** sets fans to normal operation, but if a fan error is detected, the fan that has reported an error speeds up to 100% for a short period and then returns to normal operation. If the fan error is still detected after three attempts at cleaning, the fan returns to normal operation but continues to report a fan error. This feature works independently for each of the fans. Attempts at cleaning are reset to zero if the fixture is reset or if **FAN CLEAN MODE** is updated.

Forced sets all fans to 100% speed until another **FAN CLEAN MODE** setting is selected.

This feature does not eliminate the need to inspect and clean cooling fans at regular intervals (see “Cleaning” on page 34).

- **FAN MODE** allows you to set fans to **Always on** or **Follow lamp off** mode, in which fan operation is disabled when the lamp is powered off.
- **DIMMING CURVE** provides four dimming options (see Figure 11):

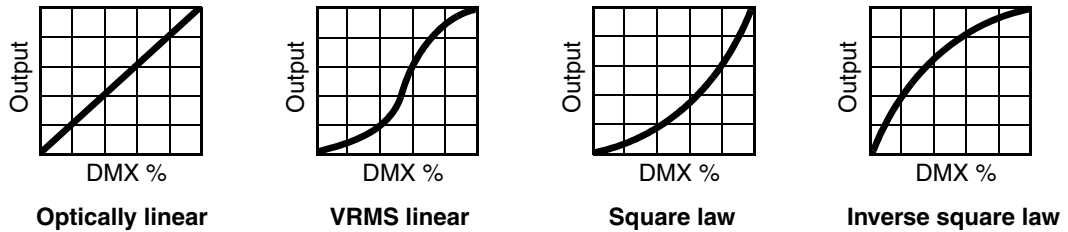

Figure 11: Dimming curve options

- **Optically linear** – the increase in light intensity appears to be linear as DMX value is increased.
- **VRMS linear (S-curve)** – light intensity control is finer at low levels and high levels and coarser at medium levels. This curve emulates the RMS voltage dimming characteristics of an incandescent lamp such as the tungsten halogen lamp of the Martin™ MAC TW1™.
- **Square law** – light intensity control is finer at low levels and coarser at high levels.
- **Inverse square law** – light intensity control is coarser at low levels and finer at high levels.
- **FOCUS TRACKING** sets focus to automatically self-adjust when you use the zoom effect (see “Zoom/focus linking” on page 24).
- **FOLLOWSPOT MODE** enables pan, tilt, or pan and tilt movement to be unlocked so that the head of the fixture can be directed by hand using a user-supplied handle (see “Followspot” on page 24). In followspot mode the motors can be applied as a brake to pan, tilt, or both pan and tilt movement to prevent head movement when the fixture is not “manned”; in this case DMX or menu-based control over pan and tilt is still disabled.
- **AUTOMATIC LAMP ON** gives three lamp strike options:
 - When set to **Off**, the lamp remains off until a “lamp on” command is received via DMX.
 - When set to **On**, the lamp strikes automatically after the fixture is powered on.
 - When set to **DMX**, the lamp strikes automatically when the fixture begins to receive DMX data, and lamp power is shut down 15 minutes after the fixture stops receiving DMX data. Automatic lamp strikes are staggered to prevent all lamps from striking at once. The delay is determined by the fixture address. No matter what the **AUTOMATIC LAMP ON** setting is, the lamp can be struck by sending a lamp on command via DMX on channel 26 in basic mode or 29 in extended mode.
- **DMX LAMP OFF** and **DMX RESET** define whether the lamp can be powered off, or whether fixture or individual effects can be reset by sending a DMX command on channel 26 in 16-bit mode or 29 in 16-bit extended mode. If either of these settings are set to **Off**, you can override this setting and cut lamp power or reset effects by applying a special combination of DMX values (see “MAC III Profile DMX protocol” on page 42).
- **PARAMETER SHORTCUTS** determines whether the gobo wheels and color wheel take the shortest path between two positions (shortcuts enabled), crossing the open position if necessary, or always avoid the open position (shortcuts disabled).
- **DISPLAY** determines whether the display remains on permanently, or goes into sleep mode 2, 5 or 10 minutes after the last movement of the jog wheel or Escape button.
- **DISPLAY INTENSITY** lets you define the brightness of the backlit graphic display. Select **Auto** for automatic adjustment to match the ambient light level, or manually set the intensity to a level from 0% to 100%.
- **DISPLAY ROTATION** lets you rotate the display manually through 0°, 90°, 180° or 270° so that it can be read easily no matter how the fixture is oriented. If set to **Auto**, the MAC III Profile senses its orientation and rotates the display automatically.
- **ERROR MODE** enables or disables error warnings. If set to **Start**, the display is activated and lights up if the fixture needs to report an error. If set to **Silent**, the fixture does not light the display with error



warnings but error messages can still be read when the display is activated manually. In both **Start** and **Silent** modes, the status LED in the jog wheel lights amber to indicate a warning and red to indicate an error.

Factory settings

FACTORY SETTINGS lets you restore the fixture's default setup options. Effect calibration is not affected, so any effects that have been re-calibrated will not be returned to factory calibration settings.

Fixture information readouts

The following fixture information can be called up in the display:

- **FIRMWARE VERSION** displays the currently installed fixture software version.
- **POWER ON TIME** provides two counters:
 - The **TOTAL POWER ON** counter is not user-resettable and displays total hours powered on since manufacture.
 - The **RESETTABLE POWER ON** counter is user-resettable and displays the number of hours the fixture has been powered on since the counter was last reset.
- **LAMP ON TIME** provides two counters:
 - The **TOTAL LAMP ON** counter is not user-resettable and displays total hours the lamp has been powered on since manufacture.
 - The **RESETTABLE LAMP ON** counter is user-resettable and displays the number of hours the lamp has been powered on since the counter was last reset.
- **LAMP STRIKES** provides two counters:
 - The **TOTAL LAMP STRIKES** counter is not user-resettable and displays the total number of lamp strikes since manufacture.
 - The **RESETTABLE LAMP STRIKES** counter is user-resettable and displays the number of lamp strikes since the counter was last reset.
- **AIR FILTERS** provides an alert feature for service interventions:
 - The **RESETTABLE AIR FILTER** counter displays the total number of hours the fixture has been powered on since the alert timer was last cleared.
 - **SET TIME ALERT** lets you set the number of hours from **1** to **750** you want the fixture to be powered on before a service alert appears in the display. If you set this figure to **0**, the time alert is disabled.
 - **CLEAR RESETTABLE AIR FILTER** lets you reset the resettable air filter counter to zero after completing service work.
- **FIXTURE MAC ID** displays the fixture's factory-set MAC (Media Access Control) address.
- **RDM UID** displays the fixture's factory-set unique ID for identification in RDM systems.
- **FANS SPEED** provides separate status readouts from the fixture's cooling fans.
- **TEMPERATURE** provides a fixture temperature status readout.
- **POWER UNIT** provides the following readouts:
 - **MAINS VOLTAGE** displays a mains power voltage readout measured at the fixture's mains power input.
 - **LAMP VOLTAGE, LAMP CURRENT** and **LAMP WATTAGE** display readouts measured at the fixture's lamp terminals.
 - **LAMP STATE** gives a lamp status readout.
 - **IGNITER STATE** gives an igniter (starter) lamp status readout.
 - **INTENSITY** indicates current lamp intensity.

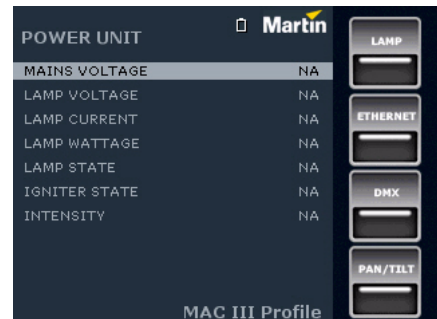
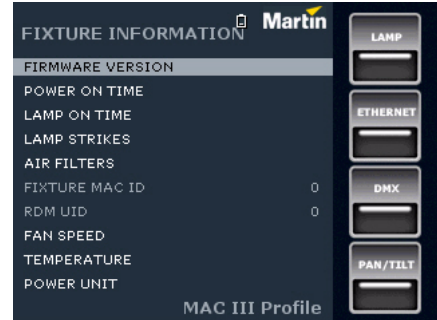

DMX signal monitoring

The MAC III Profile provides data on the DMX signal it is receiving in the **DMX LIVE** menu. This information can be useful for troubleshooting control problems.

RATE displays the DMX refresh rate in packets per second. Values lower than 10 or higher than 44 may result in erratic performance, especially when using tracking control.

QUALITY displays the quality of the received DMX data as a percentage of packets received. Values much below 100 indicate interference, poor connections, or other problems with the serial data link that are the most common cause of control problems.

START CODE displays the DMX start code. Packets with a start code other than 0 may cause irregular performance.

The remaining options under **DMX LIVE** display the DMX values in a range from 0 - 255 that are being received on each channel. The DMX channels shown will depend on whether the fixture is in 16-bit or 16-bit extended mode.

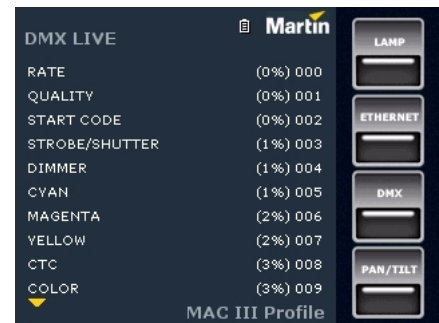

Test sequence

TEST SEQUENCE activates all effects in sequence, allowing you to test them quickly without a DMX controller.

The sequence can be started, paused, stopped and set to repeat.

Status readouts for the test sequence are given below the **ACTION** and **REPEAT** commands.

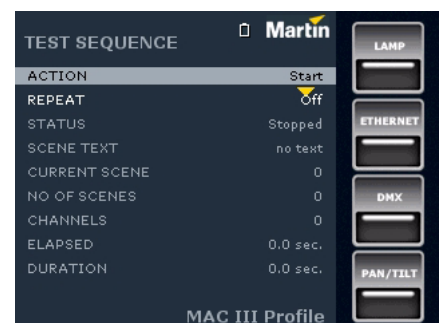

Manual control

The **MANUAL CONTROL** menu lets you reset the fixture, strike our douse the lamp, apply effects and move pan and tilt manually.



Setup Wizard menu

The **SETUP WIZARD** menu gives quick access to the most frequently required items in the control menus.



Adjusting settings via DMX

Certain fixture settings and parameters can be adjusted from the DMX controller on DMX channels 26 and 27 in 16-bit mode or channels 29 and 30 in 16-bit extended mode.

Commands sent via DMX override any settings entered in the fixture's onboard control menus. However, to reset the fixture, reset individual effects or cut power to the lamp via DMX if **DMX Reset** or **DMX Lamp Off** are disabled in the control menus, the following conditions must be met:

- Slot 1 must be selected on the color wheel (DMX value 20 on channel 7 in 16-bit mode or 8 in 16-bit extended mode),
- the prism must be on (DMX value 80-89 on channel 17 in 16-bit or channel 18 in 16-bit ext.), and
- open gobo must be selected on both gobo wheels (DMX value 0 on channels 8 and 9 in 16-bit or channels 11 and 12 in 16-bit ext.).

Note also that a lamp off command sent by DMX must be applied for 5 seconds before it executes.

These requirements are a safeguard to help you avoid resetting the fixture or powering the lamp off accidentally.

Resetting

Either the entire fixture or individual effects can be reset to their initial positions. Resetting individual effects can allow on-the-fly recovery if an effect loses its correct position, for example, without having to reset the entire fixture.

Lamp on / off

The lamp can be struck and doused from the DMX controller.

A peak of electric current that is many times the operating current is drawn for a fraction of a second when striking a discharge lamp. Striking many lamps at once may cause a voltage drop large enough to prevent lamps from striking or draw enough current to trip electronic circuit breakers. If sending lamp-on commands to multiple fixtures, program a sequence that strikes lamps one at a time.

Adjusting lamp power

If full light output is not required, the power supplied to the lamp by the ballast can be reduced. Reducing lamp power reduces heat output and therefore reduces noise from the cooling fans. It also reduces power consumption, and it helps reduce the gradual fall in output that occurs over the lifetime of a discharge lamp.

Lamp power can be set to 100%, 90%, 80%, 70% or 60% via DMX using the ballast output control commands available on channel 26 (16-bit) or 29 (16-bit extended).

If the shutter and/or dimmer are closed for longer than 10 seconds, lamp power is automatically switched to 60% of full power. When the shutter is opened again, the lamp returns to full power.

Illuminating the display

The fixture's display panel can be brought out of sleep mode with a DMX command. This makes it possible to read the fixture's DMX address while the fixture is installed in the rig.

After being illuminated in this way, the display will return to sleep mode according to the setting entered in the onboard control menus.

Control menu setting overrides

The following fixture settings can be adjusted via DMX, overriding the settings entered in the onboard control menus. See under "Control panel operations" on page 14 for details of these parameters.

- Dimming curve
- Parameter shortcuts
- Zoom/focus linking

- Pan/tilt limits
- Calibration offsets

Defining calibration offsets via DMX

The "Fixture adjustments/calibration" DMX channel allows effect offsets to be adjusted and stored in the fixture from the DMX controller.

To adjust an effect offset:

1. Set the effect to a DMX value from 0 to 255 on its own DMX channel (for example, set Cyan to 192 on channel 3 in 16-bit mode or 4 in 16-bit extended mode).
2. Send a 'Store' command for the effect on the Fixture Adjustment/Calibration channel (for example, send DMX value 130-134 on channel 27 in 16-bit mode or 30 in 16-bit extended mode to store the Cyan adjustment).

The MAC III Profile now reads the value on the effect channel (192 for Cyan in the example above), translates it to an adjustment value of between -5% and +5% as shown in Figure 12 (+2.5% Cyan adjustment in the example above) and stores that offset in memory.

See "Fixture adjustments/calibration" in the DMX protocol on page 47 for details of the offsets that can be adjusted using this method.

Effect offsets stored in memory are not affected by powering the fixture off and on or by updating the fixture software. To return all offsets to their factory defaults, send a DMX value from 245 to 249 on the "Fixture adjustments/calibration" channel or apply **LOAD FACTORY SETTINGS** in the **FACTORY SETTINGS** menu in the fixture's control panel.

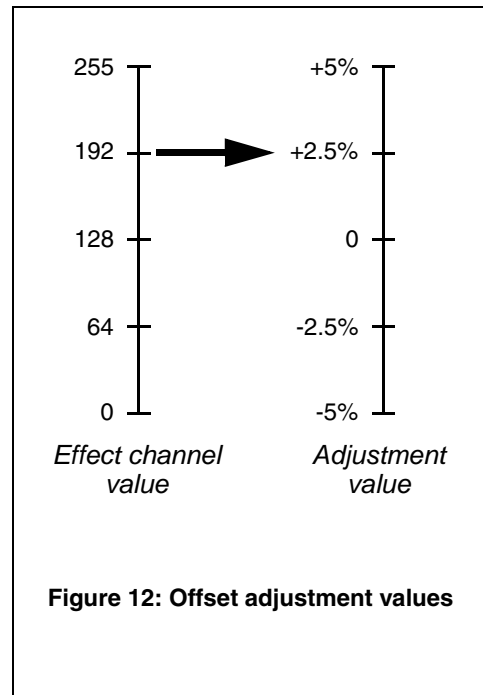

Effects

This section gives details of the effects that can be controlled via DMX. See “MAC III Profile DMX protocol” on page 42 for details of the channels used to control them.

Where fine control is available, the main control channel sets the first 8 bits (the most significant byte or MSB), and the fine channels set the second 8 bits (the least significant byte or LSB) of the 16-bit control byte. In other words, the fine channel works within the position set by the coarse channel.

Shutter and strobe effects

The MAC III Profile’s mechanical shutter provides regular or random strobe and pulse effects with variable speed from 2 Hz to 10 Hz approximately.

To ensure total blackout, the mechanical dimmer also deploys if the shutter is closed for more than 5 seconds.

Dimming

The MAC III Profile’s mechanical dimmer provides smooth, high-resolution 100 percent fading.

Fine control of the dimmer is available in 16-bit extended mode.

To ensure total blackout, the mechanical shutter also deploys if the dimmer is reduced to 0% for more than 5 seconds.

Cyan, Magenta, Yellow and CTO

The amount of cyan, magenta, yellow and CTO (color temperature control orange) applied to the MAC III Profile’s light output can be varied from zero to 100%.

Color wheel

The color wheel has 7 color filters that can be applied as split colors or in full-color steps. The color wheel can also be scrolled continuously, applying the color filters in sequence with control of color wheel speed and direction. Color filters can also be applied at random at fast, medium or slow speed.

Rotating gobos

The two rotating gobo wheels each have five rotating gobos that can be selected, indexed (positioned at an angle), rotated continuously, and shaken (bounced). The gobo wheels can also be scrolled continuously or shaken. Indexing, continuous gobo rotation, gobo shake and continuous gobo wheel scrolling are selected on one channel for each gobo wheel. Depending on what is selected on this first channel for each gobo wheel, the indexed angle or rotation speed are set on the next channel. If gobo indexing is selected on the first channel, fine control of gobo index angle is available on the third gobo wheel control channel for each gobo wheel in both 16-bit and 16-bit extended modes.

Gobo animation

The gobo animation system lets you create animated effects by rotating the animation wheel and masking the resulting pattern with one (or even two) gobos.

The system uses two channels:

- On the first channel, you set the animation wheel so that its pattern is horizontal, vertical or set at an indexed angle, with the animation wheel either static or rotating.
- On the second channel, you can either set the indexed angle of the animation wheel pattern (if you have set the animation wheel to a static position on the first channel), or set the animation wheel direction and speed (if you have selected rotation on the first channel).

When projecting onto a surface or stage, setting the pattern to horizontal with very slow rotation can simulate windswept clouds, for example, and setting the pattern close to vertical with faster rotation can simulate flames. Adjust the fixture's focus to obtain the most realistic results.

The animation wheel can also give mid-air and linear projection effects that are different from rotating gobo effects in that they do not rotate around a center axis.

Beam effect (rotating prism)

The four-facet prism can be applied at indexed angles or rotated with variable direction and speed.

Iris

The iris can be set to a static diameter, or regular and random pulsing effects can be set with variable speed.

Focus and zoom

The focus lens focuses the beam from approximately 2 meters (6.5 feet) to infinity.

The separate zoom lens varies the focused beam angle from 11.5° to 55° with the standard lens installed.

Zoom/focus linking

Focus can be linked to zoom so that it automatically adjusts to match changes in zoom angle. Focus on rotating gobos matches zoom closely, while focus on the gobo animation wheel matches zoom best in the center of the zoom range and slightly less precisely at the two extremes of the zoom range.

Linked zoom/focus works within 3 distance ranges:

- Near (5 - 10 meters)
- Medium (10 - 20 meters)
- Far (20 meters - infinity)

To link zoom and focus, select a distance range using the Fixture Control/Settings DMX channel or **FOCUS TRACKING** in the **PERSONALITY** menu in the control panel. Then adjust focus to obtain the required degree of sharpness. Linking is now enabled and focus will auto-adjust.

Pan and tilt

Coarse and fine pan and tilt control are available in both 16-bit and 16-bit extended modes.

Maximum and minimum pan and tilt limits can be set using the control panel (see "Personality – tailoring performance" on page 16) and via DMX.

Followspot

The Martin™ MAC III™ Profile fixture software from version 1.3.0 features a followspot mode in which the fixture ignores any pan, tilt, or pan and tilt commands sent via DMX or the control menu, releasing the head for use as a followspot. Fixtures running software versions older than version 1.3.0 must be upgraded with a license from Martin in order to unlock the followspot mode.

In followspot mode the pan and/or tilt motors can be engaged or disengaged from the control menu as a brake to pan, tilt, or both pan and tilt movement, to prevent head movement when the fixture is not "manned"; in this case DMX or menu-based control over pan and tilt is still disabled (see "Personality – tailoring performance" on page 16 and "Control panel menus" on page 48).

Followspot handles can be custom-made by the user to suit the user's own preferences and requirements.

Safety precautions



Warning! It is the user's responsibility to ensure that the followspot handles and any mounting brackets are safe and that the fixture is kept in followspot mode at all times while handles are installed to avoid collision between the followspot handles and the yoke.

Warning! Intermediate brackets for permanent mounting on the back of the MAC III Profile head must be constructed so that they will not touch the yoke at any point in the head's tilt range!

Warning! Screws used to fasten any item to the rear of the head may only be fastened into the holes (arrowed in Figure 13) provided in the rear head cover. Do not attempt to fasten any item to the rear of the head by any other method. Screws must not protrude more than 15 mm (0.6 inches) into the rear head cover, or there is a danger that they may damage insulation inside the head and create a risk of serious or lethal electric shock for the operator.

Warning! Followspot handles must be insulated so that it is impossible for the operator to suffer discomfort or a burn injury.

Handle use and construction

The MAC III Profile's rear head cover is a magnesium alloy casting. Magnesium alloy is prone to galvanic corrosion when steel screws are fastened into it and has a relatively low resistance to mechanical wear on threads. Self-tapping screws fastened into magnesium alloy should be left there permanently.

If you are going to switch between using the MAC III Profile as a manually-controlled followspot and as a DMX-controlled moving head from time to time, you will need to install and remove followspot handles. In this case, we recommend that you fabricate two intermediate mounting brackets in a suitable material for repeated installation and removal of screws, fasten the brackets permanently to the rear head cover, and use these brackets as mounting points for the followspot handles.

If followspot handles are going to be installed permanently, there is no need for intermediate brackets.

The design of the brackets and followspot handles is left up to the user to match user requirements, but the following points must be noted:

- Intermediate mounting brackets must be as light as possible in order to minimize the effect of their extra weight on the balance of the head. It may be best to make them in aluminium.
- Four holes (arrowed in Figure 13) are provided in the MAC III Profile rear head cover for fastening followspot handle mounting brackets.
- On most MAC III Profile fixtures manufactured before August 2009, the four holes are drilled but not threaded. In this case, use M6 thread-forming screws (DIN 7500) to fasten mounting brackets. Torx head screws are recommended because considerable force will be required to tighten the screws into the rear cover.
- On some of the first MAC III Profile fixtures manufactured, the four holes are threaded. In this case, regular M6 machine screws can be used for attachment.
- Whatever type of screw used, the portion of the screw that goes into the rear head cover must have a length of between 12 mm (0.47 in.) and 15 mm (0.6 in.).
- The rear head cover becomes very hot. Ensure that handles are insulated well enough to avoid discomfort or burn injuries for the followspot operator.
- A handle must only be fitted after followspot mode is enabled and tilt is performed manually. Always remove any handle that is fitted before disengaging followspot mode.

Besides being constructed so that they will not foul the yoke at any point in the tilt range, mounting brackets must match the dimensions shown in Figure 13.

Dimensions in Figure 13 are shown in millimeters:

- 216.8 mm = 8.53 in.
- 230.7 mm = 9.08 in.
- 78.9 mm = 3.11 in.

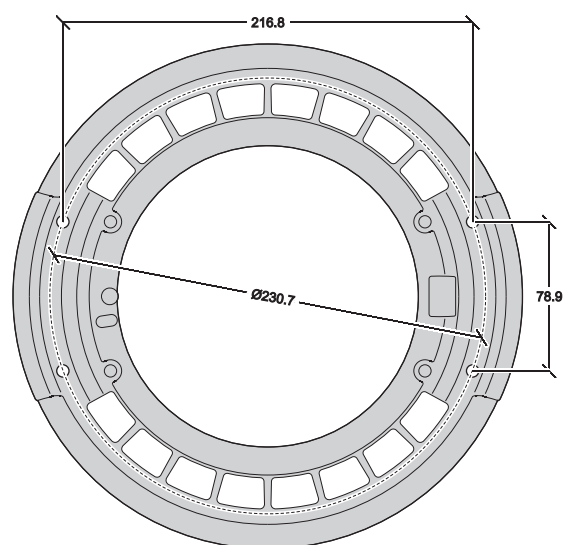

Figure 13: Dimensions for handle

Optical configuration

Color wheel

The MAC III Profile features a color wheel with 7 interchangeable dichroic color filters and an open position. As standard the MAC III Profile is supplied with the following color filters:

- Slot 1 - Blue 101 - P/N 46404500
- Slot 2 - Green 203 - P/N 46404510
- Slot 3 - Orange 311 - P/N 46404520
- Slot 4 - Minus green - P/N 46404540
- Slot 5 - Yellow 610 - P/N 46404530
- Slot 6 - Congo - P/N 46404550
- Slot 7 - Red 310 - P/N 46404560
- Slot 8 - Open

The DMX Protocol on page 42 gives details of color filter selection.

Animation wheel

The MAC III Profile is supplied with the “Tribal waves” gobo animation wheel (P/N 62325143) installed. See under “Specifications” on page 58 for full details of this component. Additional stock patterns will be available as accessories from Martin dealers.

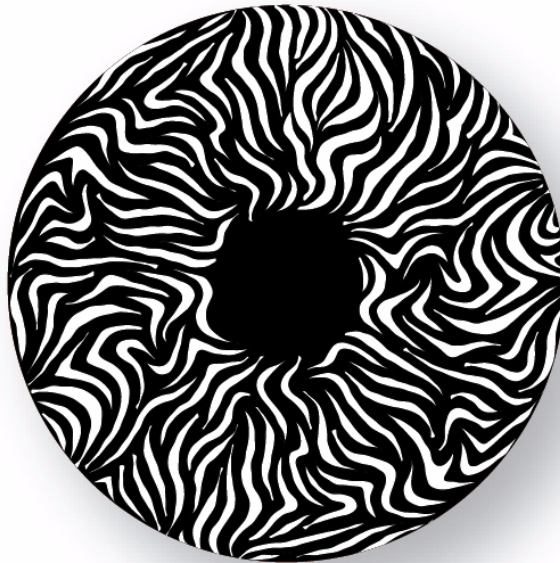

Figure 14: Tribal waves gobo animation wheel

Gobos

The two gobo wheels in the MAC III Profile each provide 5 rotating gobos plus an open position. The standard gobos are shown in the correct order in Figure 15 on page 27.

All gobos are interchangeable, but replacement gobos must match the dimensions, construction and quality of the gobos supplied as standard (see under “Specifications” on page 58).

Handling, installing and storing the gobos in the MAC III Profile requires special care. See “Gobos in the MAC III Profile” on page 37 for details.

Rotating gobo wheel 1

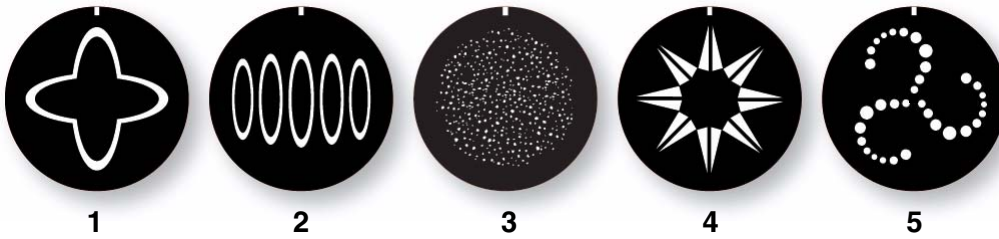

Rotating gobo wheel 2



Gobo wheel 1	
1. 4-D cone	P/N 43042039
2. 5 circles in line	P/N 43042040
3. Snow storm.....	P/N 43042050
4. Spikes	P/N 43042042
5. Pin wheel	P/N 43042043

Gobo wheel 2	
1. Lasercone single.....	P/N 43042053
2. Mikado	P/N 43042045
3. Limbo/Crystal (in holder)..	P/N 62325128
4. Cloud flames.....	P/N 43042046
5. Gridlock (in holder)	P/N 62325145

Figure 15: Rotating gobos in gobo wheels 1 and 2

Remote device management

The MAC III Profile can communicate with remotely managed devices in accordance with ESTA's *American National Standard E1.20-2006: Entertainment Technology RDM Remote Device Management Over DMX512 Networks*.

RDM (Remote Device Management) is a bi-directional communications protocol for use in DMX512 control systems, it is the open standard for DMX512 device configuration and status monitoring.

The RDM protocol allows data packets to be inserted into a DMX512 data stream without adversely affecting existing non-RDM equipment. The RDM protocol allows a console or dedicated RDM controller to send commands to and receive messages from specific fixtures.

RDM port

In line with the RDM standard, the MAC III Profile running firmware version 1.3.0 uses Port 1 for both RDM and DMX signals. We recommend that MAC III Profile users running firmware v.1.0.0 upgrade to the latest available firmware; see "Software installation" on page 33.

RDM ID

Each MAC III Profile has an RDM UID that makes it uniquely addressable. This can be found in the control panel menus under **FIXTURE INFORMATION**. **RDM UID** shows the fixture's factory-set unique ID for identification in RDM systems.



RDM communication

The MAC III Profile running firmware version 1.3.0 will respond to:

1. "MAC III Profile supported standard commands"; see page 29.
2. "MAC III Profile supported manufacturer specific commands"; see page 30.

The parameter IDs listed here are described in full in the *Martin Specific RDM Parameter ID Reference* (P/N 35000231), only available online from the Martin website (<http://www.martin.com>).

MAC III Profile supported standard commands

GET allowed	SET allowed	RDM parameter ID's (slot 21-22)	Notes
		Category – Network Management	
		DISC_UNIQUE_BRANCH	
		DISC_MUTE	
		DISC_UN_MUTE	
		Category - Status Collection	
✓		QUEUED_MESSAGE	
✓		STATUS_MESSAGES	
✓		STATUS_ID_DESCRIPTION	
	✓	CLEAR_STATUS_ID	
		Category - RDM Information	
✓		SUPPORTED_PARAMETERS	
✓		PARAMETER_DESCRIPTION	
		Category – Product Information	
✓		DEVICE_INFO	
✓		DEVICE_MODEL_DESCRIPTION	
✓		MANUFACTURER_LABEL	
✓	✓	DEVICE_LABEL	
✓	✓	FACTORY_DEFAULTS	
✓		SOFTWARE_VERSION_LABEL	
		Category - DMX512 Setup	
✓	✓	DMX_PERSONALITY	
✓		DMX_PERSONALITY_DESCRIPTION	
✓	✓	DMX_START_ADDRESS	
✓		SLOT_DESCRIPTION	
		Category – Sensors	See “RDM accessible onboard sensors” on page 30
✓		SENSOR_DEFINITION	
✓	✓	SENSOR_VALUE	
		Category – Dimmer Settings	Reserved for future use
		Category – Power/Lamp Settings	
✓	✓	DEVICE_HOURS	
✓	✓	LAMP_HOURS	
✓	✓	LAMP_STRIKES	
✓	✓	LAMP_STATE	
✓	✓	LAMP_ON_MODE	
✓	✓	DEVICE_POWER_CYCLES	
		Category - Display Settings	
✓	✓	DISPLAY_INVERT	
✓	✓	DISPLAY_LEVEL	
		Category – Configuration	
✓	✓	PAN_INVERT	
✓	✓	TILT_INVERT	
✓	✓	PAN_TILT_SWAP	
✓	✓	REAL_TIME_CLOCK	
		Category – Control	
✓	✓	IDENTIFY_DEVICE	
	✓	RESET_DEVICE	
✓	✓	PERFORM_SELFTEST	
✓	✓	SELF_TEST_DESCRIPTION	

RDM accessible onboard sensors

The follow onboard sensors are RDM accessible:

FAN SPEED	LAMP R FAN
	LAMP L FAN
	BOTTOM FAN
	CMY FAN
	TOP FAN
	MAINBOARD FAN
	POWER FAN 1
	POWER FAN 2
TEMPERATURE	UI PCB
	CHARGER PCB
	BATTERY
	FAN PCB
	ANIMATION FX PCB
	GOBO FX PCB
	CMY PCB
	ZOOM FOCUS PCB
	PAN/TILT PCB
	POWER UNIT PCB
	POWER UNIT CAPACITOR
POWER UNIT	MAINS VOLTAGE
	LAMP VOLTAGE
	LAMP CURRENT
	LAMP WATTAGE

MAC III Profile supported manufacturer specific commands

GET allowed	SET allowed	RDM parameter ID's (slot 21-22)	Notes
		Category – DMX protocol settings	
✓	✓	DMX_LAMP_OFF	
✓	✓	DMX_RESET	
		Category – Stand alone settings	
		Category – Stand alone programming	
		Fixture behavioral settings	
✓	✓	EFFECT_SPEED	
✓	✓	EFFECT_SHORTCUTS	
✓	✓	LAMP_HOUR_WARNING_HOURS	Data range is 0 - 750 hours
✓	✓	AIR_FILTER_HOUR	Data range is 0 - 750 hours
✓	✓	AIR_FILTER_HOUR_WARNING_HOURS	Data range is 0 - 750 hours
✓	✓	DIMMER_CURVE	
✓	✓	FOCUS_TRACKING	
✓	✓	DISPLAY_AUTO_OFF	
		Fixture pan/tilt settings	
✓	✓	PAN_TILT_SPEED	
✓	✓	PAN_TILT_MOVE_ON_RESET	
✓	✓	PAN_TILT_LIMITATION	
✓	✓	PAN_LIMITATION_MINIMUM	
✓	✓	PAN_LIMITATION_MAXIMUM	

✓	✓	TILT_LIMITATION_MINIMUM	
✓	✓	TILT_LIMITATION_MAXIMUM	
✓	✓	PAN_TILT_LIMITATION_AREA	
		Fixture followspot settings	
✓	✓	FOLLOW_SPOT_MODE	
	✓	FOLLOW_SPOT_MODE_LOCK_TOGGLE	
✓	✓	FOLLOW_SPOT_MODE_LOCK_PAN	
✓	✓	FOLLOW_SPOT_MODE_LOCK_TILT	
		Fixture cooling settings	
✓	✓	LAMP_COOLING	
✓	✓	FAN_CLEAN	
✓	✓	FAN_MODE	
		Fixture other settings	
✓		SERIAL_NUMBER	
	✓	LICENSE_KEY	
		Third Party PID's	

Service and maintenance



Warning! Disconnect the fixture from power and allow to cool for 2 hours 45 minutes before removing any cover.



Important! Excessive dust, smoke fluid, and particulate buildup degrades performance, causes overheating and will damage the fixture. Damage caused by inadequate maintenance is not covered by the warranty.



This section lists service and maintenance operations that may be carried out by the user. Refer any operation that is not described here to a qualified Martin technician.

The MAC III Profile requires routine cleaning. The schedule depends heavily on the operating environment. It is essential to follow the cleaning guidelines given later in this section.

Tilt lock

Important! Release the tilt lock before operating the fixture.

The tilt position of the head can be locked at various angles for transportation or service. Push the lock in towards the yoke in one direction to lock the head and back in from the other side to unlock the head.

There is no pan lock on the MAC III Profile.

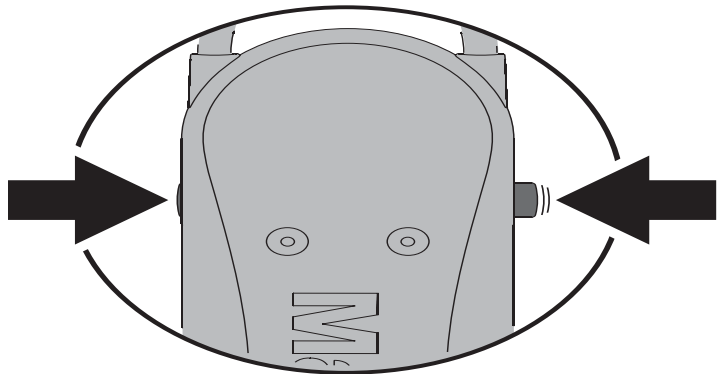

Figure 16: Tilt lock

Service utilities

The **SERVICE** menu in the main menu provides utilities for technicians rigging or servicing the fixture:

- **PAN/TILT FEEDBACK** lets you disable feedback to the fixture software from the pan, tilt and effects positioning systems. If feedback is set to **On** and a pan, tilt or effect position error is detected, the shutter closes and the effect resets. This feature can be disabled by setting feedback to **Off**.
The **Off** setting is not saved when the fixture is powered off, and the system will be re-enabled the next time the fixture starts. If a pan/tilt position error occurs and the system cannot correct pan/tilt position within 10 seconds, feedback is automatically disabled.
- **ADJUST** is for use at the factory and by authorized Martin Service technicians only. This menu allows dimmer, shutter, pan and tilt positions to be adjusted after replacement of components, etc. To adjust the default positions of all the MAC III Profile's effects, use the **CALIBRATION** menu instead.



Important! Do not enter the **ADJUST** menu without service documentation from Martin.

- **CALIBRATION** sets effects to their factory default positions or lets you set new default positions for calibration purposes. See "Calibrating effects" later in this chapter for full details.
- **UPDATE FIRMWARE**, updates the firmware (fixture software). For a detailed guide to updating the firmware, see "Software installation" later in this chapter.

Calibrating effects

The **CALIBRATION** menu lets you define offsets in software that are relative to the mechanical reset or home positions. This allows you to fine-tune optical alignment and achieve uniform performance between fixtures. Fixtures are calibrated at the factory, and further calibration will normally only be necessary if fixtures have been subjected to abnormal shocks during transport or if normal wear and tear has affected alignment after an extended period of use.

Calibrating pan and tilt sensors

When you select **PAN/TILT SENSOR CALIBRATION**, a display message appears asking you to move pan and tilt to their end stop positions. To calibrate pan and tilt:

1. Move pan to its end stop position by rotating the yoke *clockwise* (as seen from above the head looking down at the base) to maximum pan.
2. Move tilt to its end stop by tilting the head to its maximum angle with the front glass pointing away from the display panel.
3. Press the jog wheel to register the positions. The fixture will display **Saving...**

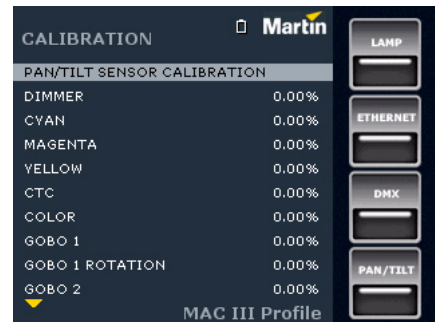

Warning! *As soon as you exit pan/tilt sensor calibration, the head will move to its original position.*

4. Make sure that you are ready for the head to move, then press the Escape button to exit pan/tilt sensor calibration. The head will now pan and tilt back to where it was before you entered calibration mode.

Calibrating effects

Calibration can be carried out via DMX (see “Defining calibration offsets via DMX” on page 22) but the easiest approach is probably to set multiple fixtures to the same position (e.g. dimmer open 1%) and then calibrate each fixture using its onboard control panel while comparing its light output with a reference fixture.

The calibration range available for each effect varies but is approx 5%. After selecting a calibration value, click on the jog wheel to set the effect to that value.

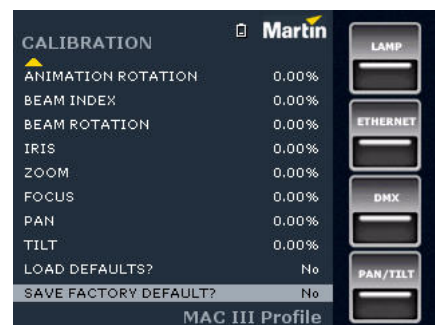

Loading and storing default calibration offsets

LOAD DEFAULTS? lets you load the factory default calibration offsets stored in memory.

SAVE FACTORY DEFAULT? lets you overwrite the factory default calibration offsets stored in memory with any new offsets you have defined. Overwriting is permanent, so once you have saved new factory default offsets, **LOAD DEFAULTS?** will reload the new offsets.

Software installation

The currently installed firmware (fixture software) version can be viewed under **FIXTURE INFORMATION** in the main menu. Firmware updates are available from the Martin website and can be installed using either of two methods:

- a USB memory device loaded with ‘bank’ files and inserted in the MAC III Profile’s USB port, or
- a Windows PC loaded with ‘MU3’ files and running the Martin Uploader application, connected to the MAC III Profile’s data input socket via a Martin Universal USB/DMX™ or a Martin DABS1™ hardware interface.

Installing using a USB memory device

The following are required in order to install firmware using a USB memory device:

- The MAC III Profile firmware ‘bank’ update file, available for download from the Product Support area of the Martin website at <http://www.martin.com>.

- A USB memory storage device (e.g. USB stick) with the update file copied from a PC into the memory device's root directory.

To install the MAC III Profile firmware:

1. Download the firmware 'bank' from the MAC III Profile support page on the Martin website at www.martin.com, read the firmware release notes carefully to check for any instructions or warnings, and copy the 'bank' to the root directory of a USB stick.
2. Disconnect the data link from the MAC III Profile.
3. Insert the USB stick in the MAC III Profile's USB host socket.
The fixture should recognize the USB stick and the **UPDATE FIRMWARE** window should pop up in the display. Alternatively, scroll to the **UPDATE FIRMWARE** menu under **SERVICE** in the control panel.
4. Select **BANK**. Scroll up and down to see the firmware versions present on the USB stick and in the fixture's internal memory. **LOCATION** indicates whether the firmware is located on the USB stick or in internal memory.
5. If you scroll to a firmware version on the USB stick and click the jog wheel, the firmware is downloaded to internal memory (where it will be available for future firmware updates), validated, unpacked and installed, and the fixture will restart using the new firmware.
6. Remove the USB stick. The newly-installed firmware version will now be displayed in the **FIXTURE INFORMATION** menu.
7. Reconnect the data link.



Zoom-focus linking is reset to default (medium distance) when new software is uploaded. Other fixture information and settings are unaffected.

Forced upload

The fixture can be forced to automatically upload a software file from a USB stick if the Escape button is held down during power up. We recommend that only one software update file is located in the memory device's root directory, but in the event that several versions are available, the fixture will upload the file with the most recent software version.

Installing using a PC and hardware interface

The following are required in order to install firmware using a PC and hardware interface:

- The MAC III Profile firmware 'MU3' update file, available for download from the Product Support area of the Martin website at <http://www.martin.com>.
- A Windows PC running the latest version of the Martin Uploader™ application (also available for download free of charge from www.martin.com) and loaded with the firmware update file.
- A USB/DMX hardware interface device such as the Martin Universal USB/DMX™ or Martin DABS1™.

To install the MAC III Profile firmware:

1. Download the firmware '.MU3' file from the MAC III Profile support page on the Martin website at www.martin.com and read the firmware release notes carefully to check for any instructions or warnings.
2. Follow the instructions for an auto upload/upload via DMX in the Martin Uploader application help files and supplied with the hardware interface.

Cleaning

Regular cleaning is very important for fixture life and performance. Buildup of dust, dirt, smoke particles, fog fluid residues, etc. degrades the fixture's light output and cooling ability.

Cleaning schedules for lighting fixtures vary greatly depending on the operating environment. It is therefore impossible to specify precise cleaning intervals for the MAC III Profile. Cooling fans suck in airborne dust and smoke particles, and in extreme cases fixtures may require cleaning after surprisingly few hours of operation. Environmental factors that may result in a need for frequent cleaning include:

- Use of smoke or fog machines.
- High airflow rates (near air conditioning vents, for example).
- Presence of cigarette smoke.
- Airborne dust (from stage effects, building structures and fittings or the natural environment at outdoor events, for example).

If one or more of these factors is present, inspect fixtures within their first 25 hours of operation to see whether cleaning is necessary. Check again at frequent intervals. This procedure will allow you to assess cleaning requirements in your particular situation. If in doubt, consult your Martin dealer about a suitable maintenance schedule.

Use care when cleaning optical components and work in a clean, well lit area. The coated surfaces are fragile and easily scratched. Do not use solvents that can damage plastic or painted surfaces.

Cleaning and replacing the air filters

1. Disconnect the fixture from power and allow the components to cool for 2 hours 45 minutes.
2. See Figure 17. On each side of the head, use a flat-bladed screwdriver to lever the front edge of each filter holder away from the head and pull the filter holders forwards to unclip and remove them.

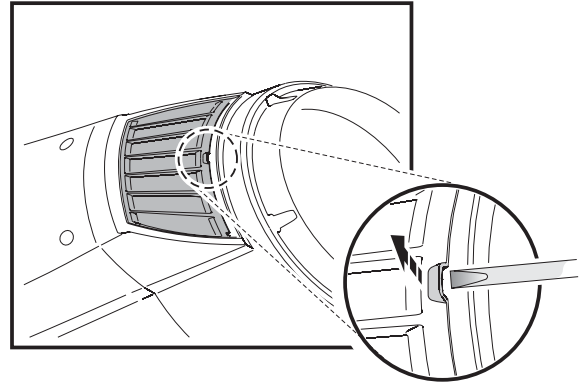

Figure 17: Removing head air filters

3. See Figure 18. On each side of the base, pinch the air filter holders in from the sides as illustrated, then pull the center of the holders outwards to unclip and remove them.
4. Clean the air filter elements. If they are saturated with smoke fluid, soak them in warm, soapy water and blot dry. If the filters cannot be cleaned completely or are not in perfect condition, replace them with new items.
5. Pinch the base filter holders in from the side and engage the ends of the filter holders their slots to clip them back into position.
6. See Figure 19. Engage the three tabs in the head filter holders in their slots in the head, pinch the foremost corners of the filter holder together slightly and press them into the head to clip them back into position.
7. Check that all filter holders are correctly installed so that there is an airtight seal around all their edges.

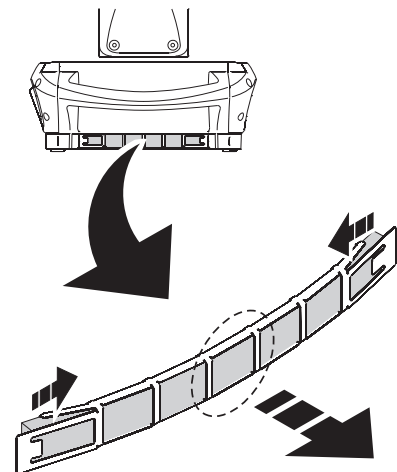

Figure 18: Base air filters

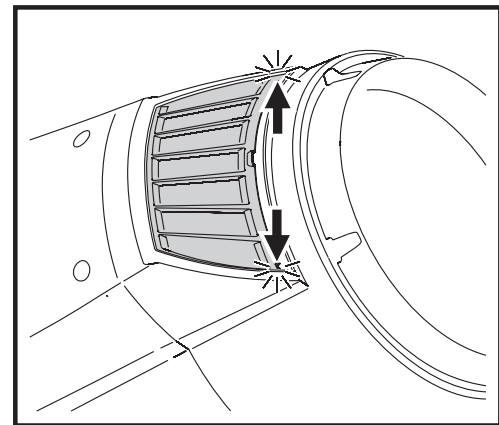
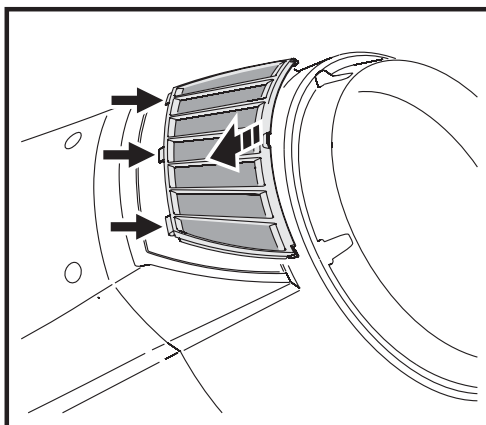

Figure 19: Reinstalling head air filters

Cleaning the fixture

To clean the head:

1. Disconnect the fixture from power and allow the components to cool for 2 hours 45 minutes.
2. Remove both head covers by loosening their quarter-turn retaining screws (see Figure 20).
3. Vacuum or gently blow away dust and loose particles inside the head with compressed air.
4. Carefully clean the optical components, but note that special precautions apply to the gobos (see "If no further service work is to be carried out, reinstall the top cover with its safety wire and release the tilt lock." on page 36). Remove smoke and other residues with cotton swabs or unscented tissues moistened with isopropyl alcohol. A commercial glass cleaner may be used, but residues must be removed with distilled water. Clean with a slow circular motion from center to edge. Dry with a clean, soft and lint-free cloth or compressed air. Remove stuck particles with an unscented tissue or cotton swab moistened with glass cleaner or distilled water. Do not rub the surface: lift the particles off with a soft repeated press.
5. Remove dust from fans and air vents with a soft brush, cotton swab, vacuum, or compressed air.
6. Reinstall the head covers.

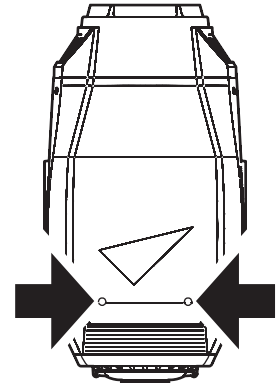

Figure 20: Head cover screws

Lubrication

The MAC III Profile does not require lubrication under normal circumstances. The slides for the zoom and focus lens cars are lubricated with a long-lasting teflon-based grease that can be reapplied by a Martin service partner if necessary.

Replacing a color filter

Note: Wear cotton gloves while handling color filters and use only genuine Martin filters.

1. Power the lamp off but leave the fixture powered on with fans running and allow it to cool.
2. The top of the head is *above* the text on the lamp cover. Lock the head in a convenient position for access to the top of the head.
3. Remove the two quarter-turn retaining screws (see Figure 20) from the top cover and lift it away from the head. Let the cover hang on its safety wire or unclip the safety wire and remove the cover completely.
4. See **A** in Figure 21 on page 37. Rotate the color wheel until the filter you want to change is accessible. Lift the filter away from the color wheel slightly to release it, then grasp it by the edges and remove. If your fingers are too large, protect the glass with a piece of paper that has been folded several times and grasp the filter with needle nose pliers.
5. To insert a filter, slide it under the retention spring until it snaps into place.
6. If no further service work is to be carried out, reinstall the top cover with its safety wire and release the tilt lock.

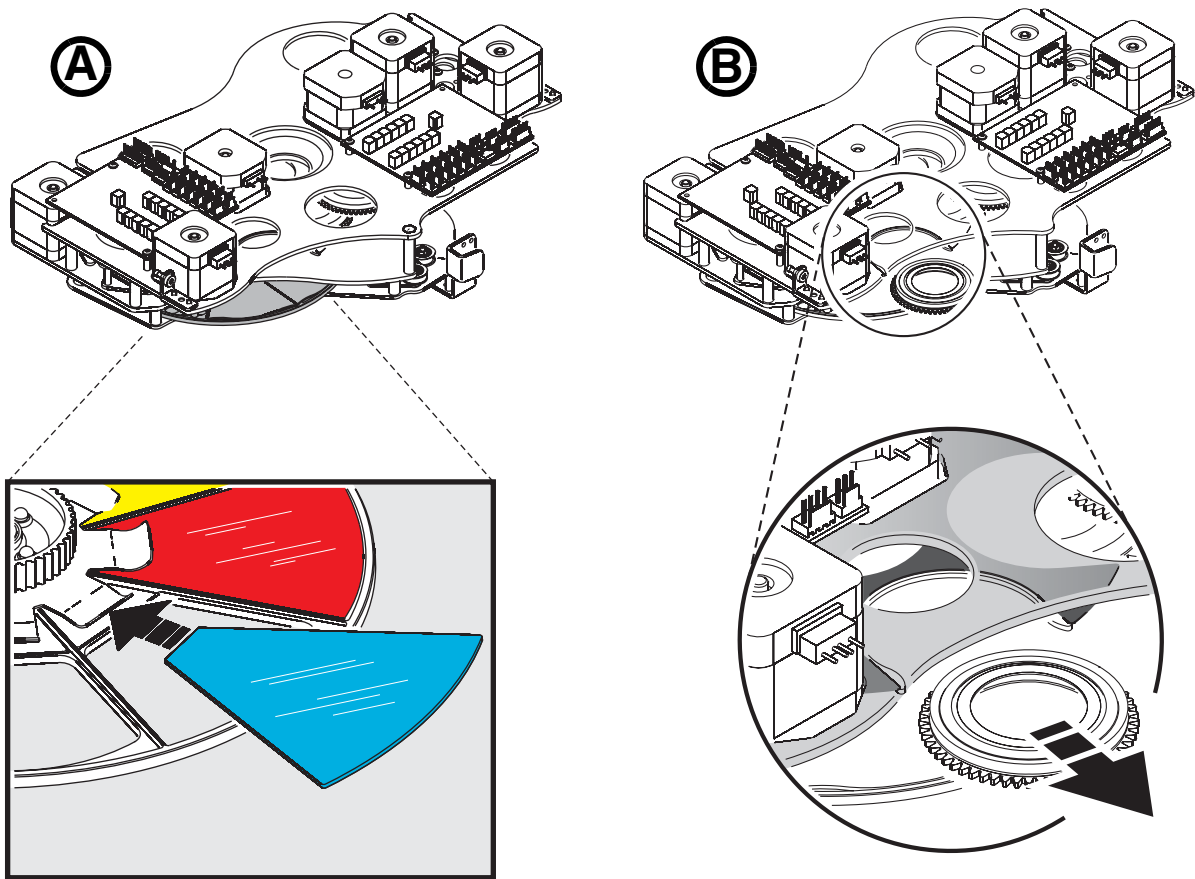

Figure 21: Color filter and gobo replacement

Gobos in the MAC III Profile

The MAC III Profile uses specially-designed borosilicate 3.3 gobos with a heavy matted aluminum coating that require particularly careful handling and storage.

The use of metal gobos in the MAC III Profile is not recommended.

Do not use gobos with dark coatings on any side, as these will absorb heat – either directly from the lamp or reflected back from other gobos and optical components – and will not be durable.

Handling and storage

1. Store all gobos in a dust-free environment with approx. 50% humidity.
2. Always use clean gloves when handling gobos.
3. Avoid touching the other gobos when taking out a gobo from the rack: the sharp edge of one gobo can scratch the others.
4. Clean the coated side of gobos with dust and oil-free compressed air only.
5. Clean the uncoated side of gobos with photographic quality lens-cleaner and optics cleaning tissues. Use a repeated dabbing action rather than a rubbing action.
6. Avoid scratching coated and uncoated sides.
7. Never place a gobo with the coated side face-down on any surface.
8. Mount the gobo with the matted coating towards the lens.

Replacing rotating gobos

Important! *The gobo can fall out if the spring is inserted backwards.*

Do not lubricate gobo bearings: excess grease can cause loss of step.

Correct gobo orientation is critical. Read the guidelines in Figure 23 carefully before installing a gobo.

To replace a gobo:

1. Open the top cover as described under “Replacing a color filter” on page 36.
2. See **B** in Figure 21 on page 37. Rotate the relevant gobo wheel until the gobo you want to replace is accessible.
3. Grasp the holder by the teeth and pull the holder lightly away from the gobo wheel to release the holder and remove it from the wheel.
4. With a small screwdriver or similar, unhook the end of the gobo spring furthest from the gobo and pull out the spring. Drop the gobo out of the holder.
5. Insert the new gobo in the holder with the side that must face towards the lamp facing upwards, towards the spring (see Figure 22 and Figure 23).
6. Insert the spring with the narrow end against the gobo, as shown in Figure 22. To identify the narrow end, press the spring flat: the narrow end is on the inside. Push the end of the spring in under the lip of the holder.
7. Check that the gobo is seated flush against the holder. Press the spring as flat as possible against the back of the gobo.
8. Check that the goboholder is the right way up (see Figure 21), then work the rim of the gobo holder under both clips and snap the gobo holder back into position on the gobo wheel. If necessary, a small screwdriver or similar tool may be used to pry the clips away from the wheel.
9. If no further service work is to be carried out, reinstall the top cover with its safety wire and release the tilt lock.

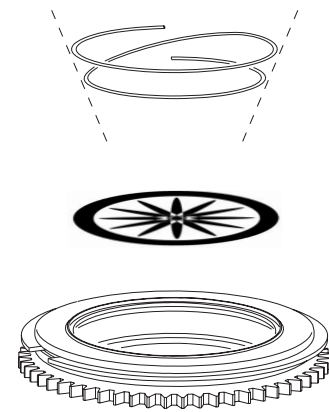

Figure 22: Rotating gobo holder

Gobo orientation

The orientations shown in Figure 23 are correct in most cases, but consult your Martin dealer or gobo supplier if you are in any doubt about the orientation of a specific gobo type.

Coated Glass Gobos

The heavy matted aluminum coated borosilicate gobos in the MAC III Profile are factory-installed with the more reflective sides facing towards the lamp. Replacement gobos must also be installed with more reflective sides facing the lamp in order to avoid heat damage.

More reflective side towards lamp

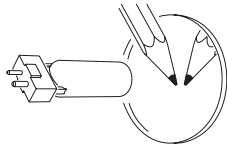

To minimize the risk of gobo overheating and damage, turn the more reflective side of a coated gobo towards the lamp.

Less reflective side away from lamp

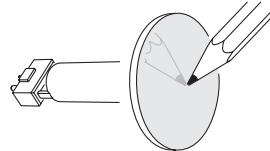

The less reflective side of a coated gobo will absorb less heat if it faces away from the lamp.

Textured Glass Gobos

Textured side towards lamp

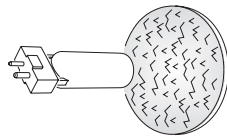

Textured glass gobos in the MAC III Profile sit most squarely in the gobo wheel with the textured side towards the lamp. If in doubt, consult your Martin dealer or gobo supplier.

Smooth side away from lamp

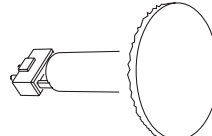
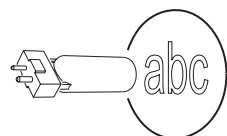

Image / text Gobos

True image towards lamp



Reversed image away from lamp

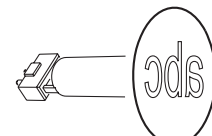

Figure 23. Correct gobo orientation

Replacing the gobo animation wheel

Important! *The gobo animation wheel is glass and must be handled gently. Do not attempt to bend it or you will break it. Breakages caused by mishandling are not covered by the product warranty.*

1. Disconnect the fixture from power and allow it to cool for 2 hours 45 minutes.
2. Apply the tilt lock in a convenient position. Open the top cover as described under “Replacing a color filter” on page 36.
3. See Figure 24. Bring the animation wheel up to the top of the head by pulling its sliding car with a finger.

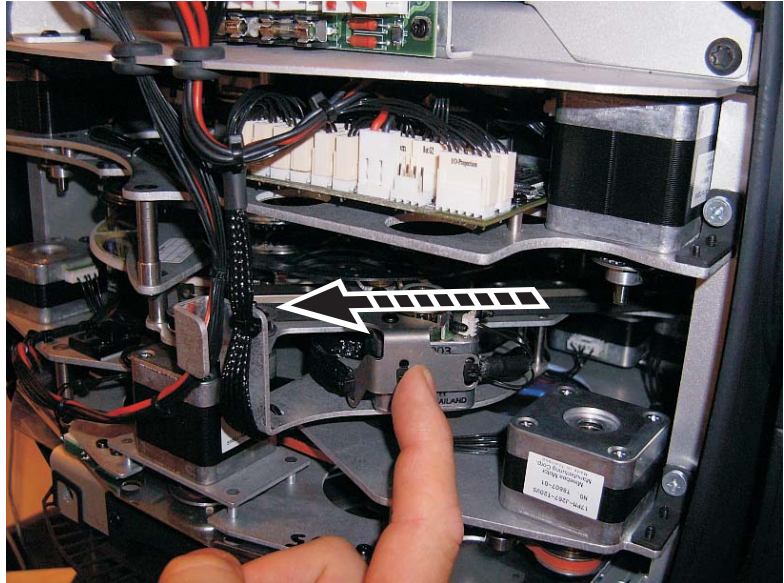

Figure 24: Animation wheel access

4. The animation wheel is retained by a magnetic hub. To avoid breaking the animation wheel while removing, release the hub by gently levering the hub off its mounting with a screwdriver. Do not apply pressure to the animation wheel itself. See Figure 25. Once the hub is released, you can safely grasp the wheel and remove it.
5. When installing an animation wheel, slide the hub in over the drive mechanism and align it with its mounting until the magnetic hub locks into place on the mounting.
6. If no further service work is to be carried out, reinstall the top cover with its safety wire and release the tilt lock before re-applying power.



Figure 25: Animation wheel removal

Removing modules

The MAC III Profile is modular in design. A full procedure for removing and servicing effect modules is included in the Martin™ service package available for the MAC III Profile.

Important! *The zoom/focus car and animation wheel must be moved to the positions described below before modules can be removed.*

1. See Figure 26. Move the zoom/focus car as far as possible towards the front lens by first pushing on one of its sliders (A), then holding it in the fully forward position by pressing on one of its drive belt pulleys (B).
2. Move the gobo animation wheel as far as possible up towards the top of the head by pulling on its drive car as shown in Figure 24 on page 40. The animation wheel is glass. Do not apply pressure to it, or you may cause damage that is not covered by the product warranty.
3. Modules are released for removal by disconnecting their multi-connectors and removing their retaining screws (arrowed in Figure 27). Take great care not to damage wiring during module removal or re-installation.

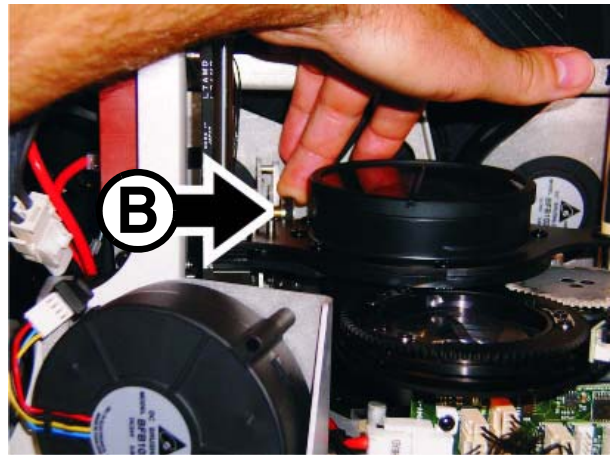
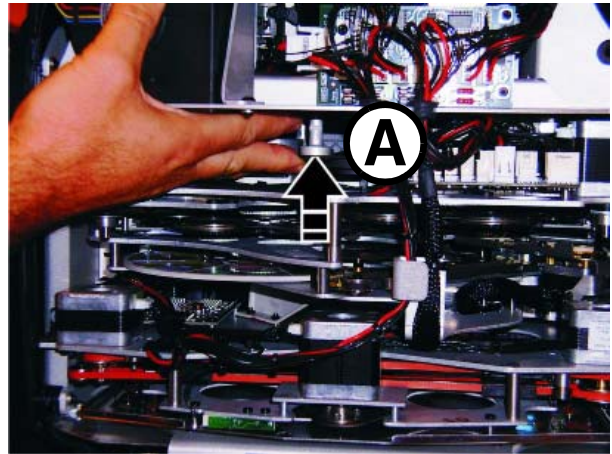

Figure 26: Moving the zoom/focus car fully forward



Figure 27: Module retaining screws

MAC III Profile DMX protocol

Applicable when running firmware version: 1.3.0

Basic 16-bit Mode	16-bit Extended Mode	DMX Value	Percent	Function
1	1	0 - 19	0 - 7	Strobe/shutter Shutter closed (Lamp Switches to 800 watt mode after shutter is closed for 10 seconds)
		20 - 49	8 - 19	Shutter open
		50 - 64	20 - 25	Strobe, fast → slow
		65 - 69	26 - 27	Shutter open
		70 - 84	28 - 33	Opening pulse, fast → slow
		85 - 89	34 - 35	Shutter open
		90 - 104	36 - 41	Closing pulse, fast → slow
		105 - 109	42 - 43	Shutter open
		110 - 124	44 - 49	Random strobe, fast → slow
		125 - 129	50 - 51	Shutter open
		130 - 144	52 - 57	Random opening pulse, fast → slow
		145 - 149	58 - 59	Shutter open
		150 - 164	60 - 65	Random closing pulse, fast → slow
		165 - 169	66 - 67	Shutter open
		170 - 184	68 - 73	Burst pulse, fast → slow
		185 - 189	74 - 75	Shutter open
		190 - 204	76 - 81	Random burst pulse, fast → slow
		205 - 209	82 - 83	Shutter open
210 - 224	84 - 89	Electronic sine wave strobe, fast → slow		
225 - 229	90 - 91	Shutter open		
230 - 244	92 - 97	Electronic burst strobe, fast → slow		
245 - 255	98 - 100	Shutter open		
2	2	0 - 255	0 - 100	Dimmer fade (MSB) Closed → open
-	3	0 - 255	0 - 100	Dimmer fade, fine (LSB)
3	4	0 - 255	0 - 100	Cyan White → full cyan
				Cyan range in random CMY color when random CMY selected on channel 14 (16-bit) or 15 (16-bit extended)
		0	0	Normal (full range)
		1 - 127	1 - 50	Minimum cyan setting (127 = full cyan)
		128 - 254	51 - 99	Maximum cyan setting (128 = no cyan)
255	100	Normal (full range)		
4	5	0 - 255	0 - 100	Magenta White → full magenta
				Magenta range in random CMY color when random CMY selected on channel 14 (16-bit) or 15 (16-bit extended)
		0	0	Normal (full range)
		1 - 127	1 - 50	Minimum magenta setting (127 = full magenta)
		128 - 254	51 - 99	Maximum magenta setting (128 = no magenta)
255	100	Normal (full range)		
5	6	0 - 255	0 - 100	Yellow White → full yellow
				Yellow range in random CMY color when random CMY selected on channel 14 (16-bit) or 15 (16-bit extended)
		0	0	Normal (full range)
		1 - 127	1 - 50	Minimum yellow setting (127 = full yellow)
		128 - 254	51 - 99	Maximum yellow setting (128 = no yellow)
255	100	Normal (full range)		
6	7	0 - 255	0 - 100	CTO Open (cold) → warm

Basic 16-bit Mode	16-bit Extended Mode	DMX Value	Percent	Function
7	8			Color Wheel
				<i>Continuous Scroll</i>
		0	0	Open
		1 - 19	1 - 7	Open → Slot 1 - Blue
		20	8	Slot 1
		21 - 39	9 - 15	Slot 1 → Slot 2 - Green
		40	16	Slot 2
		41 - 59	17 - 23	Slot 2 → Slot 3 - Orange
		60	24	Slot 3
		61 - 79	25 - 31	Slot 3 → Slot 4 - Minus green
		80	32	Slot 4
		81 - 99	33 - 39	Slot 4 → Slot 5 - Yellow
		100	40	Slot 5
		101 - 119	41 - 47	Slot 5 → Slot 6 - Congo (deep blue)
		120	48	Slot 6
		121 - 139	49 - 55	Slot 6 → Slot 7 - Red
		140	56	Slot 7
		141 - 159	57 - 63	Slot 7 → Open
		160	64	Open
				<i>Stepped Scroll (snap to full color positions)</i>
		161 - 164	65 - 66	Slot 7 - Red
		165 - 168	67 - 68	Slot 6 - Congo (deep blue)
		169 - 172	69 - 70	Slot 5 - Yellow
		173 - 176	71 - 72	Slot 4 - Minus green
		177 - 180	73 - 74	Slot 3 - Orange
		181 - 184	75 - 76	Slot 2 - Green
		185 - 188	77 - 78	Slot 1 - Blue
		189 - 192	79 - 80	Open
				<i>Continuous Rotation</i>
		193 - 214	81 - 86	CW, Fast → Slow
215 - 221	87 - 88	Stop (This will stop wherever the wheel is at the time)		
222 - 243	89 - 94	CCW, Slow → Fast		
		<i>Random color</i>		
244 - 247	95 - 96	Fast		
248 - 251	97 - 98	Medium		
252 - 255	99 - 100	Slow		
8	9			Gobo wheel 1: gobo selection, indexing, shake, rotation
				<i>Indexed gobo: set indexed angle on channel 9 (16-bit) or 10 (16-bit ext.)</i>
		0 - 9	0 - 4	Open
		10 - 14	4 - 5	Gobo 1 - 4-D cone
		15 - 19	5 - 8	Gobo 2 - 5 circles in line
		20 - 24	8 - 10	Gobo 3 - Snow storm
		25 - 29	10 - 12	Gobo 4 - Spikes
		30 - 34	12 - 14	Gobo 5 - Pin wheel
				<i>Continuous gobo rotation: set gobo rotation speed on channel 9 (16-bit) or 10 (16-bit ext.)</i>
		35 - 39	14 - 16	Gobo 1 - 4-D cone
		40 - 44	16 - 18	Gobo 2 - 5 circles in line
		45 - 49	18 - 20	Gobo 3 - Snow storm
		50 - 54	20 - 22	Gobo 4 - Spikes
		55 - 59	22 - 24	Gobo 5 - Pin wheel
				<i>Gobo shake centered on indexed position: set indexed angle on channel 9 (16-bit) or 10 (16-bit ext.). Shake angle increments in following steps: 10°, 15°, 30°, 45°, 60°, 90°, 135°, 180°, 270° and 360°</i>
		60 - 89	24 - 34	Gobo 1 - 4-D cone, 360° slow → 10° fast
		90 - 119	35 - 45	Gobo 2 - 5 circles in line, 360° slow → 10° fast
		120 - 149	46 - 56	Gobo 3 - Snow storm, 360° slow → 10° fast
		150 - 179	57 - 67	Gobo 4 - Spikes, 360° slow → 10° fast
		180 - 209	68 - 78	Gobo 5 - Pin wheel, 360° slow → 10° fast
				<i>Continuous gobo wheel scroll with continuous gobo rotation: set gobo rotation speed on channel 9 (16-bit) or 10 (16-bit extended)</i>
		210 - 232	79 - 89	CW scroll, fast → slow
		233 - 255	90 - 100	CCW scroll, slow → fast

Basic 16-bit Mode	16-bit Extended Mode	DMX Value	Percent	Function
9	10	0 - 255	0 - 100	Gobo wheel 1: indexing, direction, speed (MSB) <i>If indexed gobo is selected on channel 8 (16-bit) or 9 (16-bit ext.)</i> Rotating gobo indexing, 0 → 395°
		0 - 2	0	<i>If continuous gobo rotation is selected on channel 8 (16-bit) or 9 (16-bit ext.)</i> No rotation
		3 - 126	1 - 50	CW, fast → slow
		127 - 129	51	No rotation
		130 - 253	52 - 99	CCW, slow → fast
		254 - 255	100	No rotation
10	11	0 - 255	0 - 100	Gobo wheel 1: rotating gobo fine indexing or rotation speed (LSB) <i>If indexed gobo is selected on channel 8 (16-bit) or 9 (16-bit ext.)</i> Rotating gobo indexing, fine
		0 - 255	0 - 100	<i>If continuous gobo rotation is selected on channel 8 (16-bit) or 9 (16-bit ext.)</i> Rotating gobo rotation speed, fine
11	12	0 - 9	0 - 4	Gobo wheel 2: gobo selection, indexing, shake, rotation <i>Indexed gobo: set indexed angle on channel 12 (16-bit) or 13 (16-bit ext.)</i> Open
		10 - 14	4 - 5	Gobo 1 - Lasercone single
		15 - 19	5 - 8	Gobo 2 - Mikado
		20 - 24	8 - 10	Gobo 3 - Limbo/Crystal
		25 - 29	10 - 12	Gobo 4 - Cloud flames
		30 - 34	12 - 14	Gobo 5 - Gridlock
				<i>Continuous gobo rotation: set gobo rotation speed on channel 12 (16-bit) or 13 (16-bit ext.)</i> Gobo 1 - Lasercone single
		35 - 39	14 - 16	Gobo 2 - Mikado
		40 - 44	16 - 18	Gobo 3 - Limbo/Crystal
		45 - 49	18 - 20	Gobo 4 - Cloud flames
		50 - 54	20 - 22	Gobo 5 - Gridlock
		55 - 59	22 - 24	<i>Gobo shake centered on indexed position: set indexed angle on channel 9 (16-bit) or 10 (16-bit ext.). Shake angle increments in following steps: 10°, 15°, 30°, 45°, 60°, 90°, 135°, 180°, 270° and 360°</i> Gobo 1 - Lasercone single, 360° slow → 10° fast
		60 - 89	24 - 34	Gobo 2 - Mikado, 360° slow → 10° fast
		90 - 119	35 - 45	Gobo 3 - Limbo/Crystal, 360° slow → 10° fast
		120 - 149	46 - 56	Gobo 4 - Cloud flames, 360° slow → 10° fast
150 - 179	57 - 67	Gobo 5 - Gridlock, 360° slow → 10° fast		
180 - 209	68 - 78	<i>Continuous gobo wheel scroll with continuous gobo rotation: set gobo rotation speed on channel 9 (16-bit) or 10 (16-bit ext.)</i> CW scroll, fast → slow		
		210 - 232	79 - 89	CCW scroll, slow → fast
		233 - 255	90 - 100	
12	13	0 - 255	0 - 100	Gobo wheel 2: indexing, direction, speed (MSB) The default value for this channel = 128 <i>If indexed gobo is selected on channel 11 (16-bit) or 12 (16-bit ext.)</i> Rotating gobo indexing, 0 → 395°
		0 - 2	0	<i>If continuous gobo rotation is selected on channel 11 (16-bit) or 12 (16-bit ext.)</i> No rotation
		3 - 126	1 - 50	CW, fast → slow
		127 - 129	51	No rotation
		130 - 253	52 - 99	CCW, slow → fast
		254 - 255	100	No rotation
13	14	0 - 255	0 - 100	Gobo wheel 2: rotating gobo fine indexing or rotation speed (LSB) <i>If indexed gobo is selected on channel 11 (16-bit) or 12 (16-bit ext.)</i> Rotating gobo indexing, fine
		0 - 255	0 - 100	<i>If continuous gobo rotation is selected on channel 11 (16-bit) or 12 (16-bit ext.)</i> Rotating gobo rotation speed, fine

Basic 16-bit Mode	16-bit Extended Mode	DMX Value	Percent	Function
14	15	0 - 18	0 - 6	Color shake / random CMY No effect (Note: this value is used for setting calibration values on ch. 27/30) Color wheel: fast narrow shake fast → slow wide shake, around currently selected color <i>Random CMY: set min./ max. CMY range limits on channels 3 - 5 (16-bit) or 4 - 6 (16-bit ext.)</i> Fast Medium Slow <i>Reserved for future use</i>
		19 - 57	7 - 22	
		58 - 83	23 - 32	
		84 - 109	33 - 42	
		110 - 135	43 - 52	
		136 - 255	53 - 100	
15	16	0 - 5	0 - 2	Gobo animation wheel: position and function Open Horizontal indexed position: set indexing on ch. 16 (16-bit) or 17 (16-bit ext.) Vertical indexed position: set indexing on ch. 16 (16-bit) or 17 (16-bit ext.) Horizontal position, continuous rotation: set direction & speed on ch. 16 (16-bit) or 17 (16-bit ext.) Vertical position, continuous rotation: set direction & speed on ch. 16 (16-bit) or 17 (16-bit ext.) Angled position, vertical → horizontal, continuous rotation: set direction & speed on ch. 16 (16-bit) or 17 (16-bit ext.) Angled position, horizontal → vertical: set indexing on ch. 16 (16-bit) or 17 (16-bit ext.) Angled position, vertical → open: set indexing on ch. 16 (16-bit) or 17 (16-bit ext.)
		6 - 10	2 - 4	
		11 - 15	4 - 6	
		16 - 20	6 - 8	
		21 - 25	8 - 10	
		26 - 110	10 - 43	
		111 - 195	44 - 76	
196 - 255	77 - 100			
16	17	0 - 255	0 - 100	Gobo animation wheel: indexed angled position, rotation direction and speed <i>If indexed angled position is selected on channel 15 (16-bit) or 16 (16-bit ext.):</i> Indexed angle, 0° → 395° <i>If continuous rotation is selected on channel 15 (16-bit) or 16 (16-bit ext.):</i> No rotation CW, fast → slow No rotation CCW, slow → fast No rotation
		0 - 2	0	
		3 - 126	1 - 50	
		127 - 129	51	
		130 - 253	52 - 99	
		254 - 255	100	
17	18	0 - 19	0 - 7	Beam effect (prism) Beam effect off Beam effect 1 indexing: set angle on ch. 18 (16-bit) or 19 (16-bit ext.) Beam effect 1 rotating: set direction and speed on ch. 18 (16-bit) or 19 (16-bit ext.) Beam effect off <i>Reserved for future use</i>
		20 - 39	7 - 16	
		40 - 59	17 - 24	
		60 - 79	25 - 29	
		80 - 255	30 - 100	
18	19	0 - 255	0 - 100	Beam effect (prism) indexing, direction, speed <i>If beam effect indexing is selected on channel 17 (16-bit) or 18 (16-bit ext.):</i> Indexed angle 0° - 395° <i>If beam effect rotation is selected on channel 17 (16-bit) or 18 (16-bit ext.):</i> No rotation CW, fast → slow No rotation CCW, slow → fast No rotation
		0 - 2	0	
		3 - 126	1 - 50	
		127 - 129	51	
		130 - 253	52 - 99	
		254 - 255	100	
19	20	0 - 199	0 - 77	Iris Open → closed Closed Opening pulse, fast → slow Closing pulse, fast → slow Random opening pulse, fast → slow Random closing pulse, fast → slow
		200 - 215	78 - 84	
		216 - 229	85 - 89	
		230 - 243	90 - 94	
		244 - 249	95 - 97	
		250 - 255	98 - 100	
20	21	0 - 255	0 - 100	Focus (MSB) Infinity → near
-	22	0 - 255	0 - 100	Focus, fine (LSB)
21	23	0 - 255	0 - 100	Zoom (MSB) Flood → spot
-	24	0 - 255	0 - 100	Zoom, fine (LSB)

Basic 16-bit Mode	16-bit Extended Mode	DMX Value	Percent	Function
22	25	0 - 255	0 - 100	Pan (MSB) Left → right (128 = neutral)
23	26	0 - 255	0 - 100	Pan, fine (LSB)
24	27	0 - 255	0 - 100	Tilt (MSB) Left → right (128 = neutral)
25	28	0 - 255	0 - 100	Tilt, fine (LSB)
26	29	0 - 9	0 - 1	Fixture control/settings <i>No function</i>
		10 - 14	2 - 3	Reset entire fixture ⁽¹⁾
		15 - 19	4 - 5	Reset dimmer and shutter only ⁽¹⁾
		20 - 24	6 - 7	Reset CMYC and color wheel only ⁽¹⁾
		25 - 29	8 - 9	Reset effects module (gobo wheels 1 & 2, gobo animation, iris, prism) only ⁽¹⁾
		30 - 34	10 - 11	Reset zoom and focus only ⁽¹⁾
		35 - 39	12 - 13	Reset pan and tilt only ⁽¹⁾
		40 - 44	14 - 15	<i>No function</i>
		45 - 49	16 - 17	Lamp on
		50 - 54	18 - 19	Lamp off ^(1, 2)
		55 - 59	20 - 21	<i>No function</i> (Note: this value is used for setting calibration values on ch. 27/30)
		60 - 64	22 - 23	Dimmer curve = Optical linear (menu override, setting unaffected by power off/on) ⁽²⁾
		65 - 69	24 - 25	Dimmer curve = Square law (menu override, factory default setting, setting unaffected by power off/on) ⁽²⁾
		70 - 74	26 - 27	Dimmer curve = Inverse square law (menu override, setting unaffected by power off/on) ⁽²⁾
		75 - 79	28 - 29	Dimmer curve = S-curve (menu override, setting unaffected by power off/on) ⁽²⁾
		80 - 139	30 - 53	<i>No function</i>
		140 - 144	54 - 55	Parameter shortcuts = ON (menu override, setting stays at factory default ON at power off/on) ⁽²⁾
		145 - 149	56 - 57	Parameter shortcuts = OFF (menu override, setting returns to factory default ON at power off/on) ⁽²⁾
		150 - 154	58 - 59	<i>No function</i>
		155 - 159	60 - 61	Disable zoom/focus linking ⁽²⁾
		160 - 164	62 - 63	Enable zoom/focus linking, near distance ⁽²⁾
		165 - 169	64 - 65	Enable zoom/focus linking, medium distance (factory default setting) ⁽²⁾
		170 - 174	66 - 67	Enable zoom/focus linking, far distance ⁽²⁾
		175 - 199	68 - 77	<i>No function</i>
		200 - 204	78 - 79	Ballast output set to 100%
		205 - 209	80 - 81	Ballast output reduced, output set to 90%
210 - 214	82 - 83	Ballast output reduced, output set to 80%		
215 - 219	84 - 85	Ballast output reduced, output set to 70%		
220 - 224	86 - 87	Ballast output reduced, output set to 60%		
225 - 239	88 - 93	<i>No function</i>		
240 - 244	94 - 95	Illuminate display on fixture ⁽²⁾		
245 - 255	96 - 100	<i>No function</i>		
				⁽¹⁾ If DMX Reset or DMX Lamp Off are disabled in the control menus, a full or partial reset command or a lamp off command can be executed only if: Slot 1 is selected on the color wheel (DMX value 20 on channel 7 in 16-bit or 8 in 16-bit ext.) The prism is on (DMX value 80-89 on channel 17 in 16-bit or 18 in 16-bit ext.), and Open gobo is selected on both gobo wheels (DMX value 0 on channels 8 and 9 in 16-bit or 11 and 12 in 16-bit ext.)
				⁽²⁾ Value must be held for 5 seconds to activate

Basic 16-bit Mode	16-bit Extended Mode	DMX Value	Percent	Function
27	30	0-39	0 - 13	Fixture adjustments/calibration
		40-44	14 - 15	<i>No function: reserved for future use</i>
		45-49	16 - 17	Enable pan/tilt limitation ⁽⁴⁾
		50-54	18 - 19	<i>No function: reserved for future use</i>
		55-59	20 - 21	Disable pan/tilt limitation ⁽⁴⁾
		60-64	22 - 23	<i>No function: reserved for future use</i>
		65-69	24 - 25	Set pan/tilt limit to stay outside defined area (no-go zone) ⁽⁴⁾
		70-74	26 - 27	<i>No function: reserved for future use</i>
		75-79	28 - 29	Set pan/tilt limit to stay inside defined area (safe zone) ⁽⁴⁾
		80-84	30 - 31	<i>No function: reserved for future use</i>
		85-89	32 - 33	Store current pan position as lower pan limit ⁽⁴⁾
		90-94	34 - 35	Store current pan position as upper pan limit ⁽⁴⁾
		95-99	36 - 37	<i>No function: reserved for future use</i>
		100-104	38 - 39	Store current tilt position as lower tilt limit ⁽⁴⁾
		105-109	40 - 41	Store current tilt position as upper tilt limit ⁽⁴⁾
		110-114	42 - 43	<i>No function: reserved for future use</i>
		115-124	44 - 47	Reset pan and tilt limits ⁽³⁾
		125-129	48 - 49	<i>No function: reserved for future use</i>
		130-134	50 - 51	Store dimmer calibration ⁽⁴⁾
		135-139	52 - 53	Store cyan calibration ⁽⁴⁾
		140-144	54 - 55	Store magenta calibration ⁽⁴⁾
		145-149	56 - 57	Store yellow calibration ⁽⁴⁾
		150-154	58 - 59	Store CTC calibration ⁽⁴⁾
		155-159	60 - 61	Store CMYC calibration ⁽⁴⁾
		160-164	62 - 63	Store gobo wheel 1 slots 1 – 5 index calibration ⁽⁴⁾
		165-169	64 - 65	<i>No function: reserved for future use</i>
		170-174	66 - 67	<i>No function: reserved for future use</i>
		175-179	68 - 69	<i>No function: reserved for future use</i>
		180-184	70 - 71	Store gobo wheel 2 slots 1 – 5 index calibration ⁽⁴⁾
		185-189	72 - 73	<i>No function: reserved for future use</i>
		190-194	74 - 75	<i>No function: reserved for future use</i>
		195-199	76 - 77	<i>No function: reserved for future use</i>
200-204	78 - 79	<i>No function: reserved for future use</i>		
205-209	80 - 81	Store gobo animation wheel index calibration ⁽⁴⁾		
210-214	82 - 83	Store beam effect (prism) index calibration ⁽⁴⁾		
215-219	84 - 85	Store iris calibration ⁽⁴⁾		
220-224	86 - 87	Store focus calibration ⁽⁴⁾		
225-229	88 - 89	Store zoom calibration ⁽⁴⁾		
230-234	90 - 91	Store pan calibration ⁽⁴⁾		
235-239	92 - 93	Store tilt calibration ⁽⁴⁾		
240-244	94 - 95	<i>No function: reserved for future use</i>		
245-249	96 - 97	Reset all calibrations to factory default ⁽⁴⁾		
250-255	98 - 100	<i>No function: reserved for future use</i>		
				⁽³⁾ To activate: Value must be held for 5 seconds The CMY channels (3, 4 and 5 in 16-bit mode or 4, 5 and 6 in 16-bit extended mode) must all be set to DMX value 232 The beam effect channel (17 in 16-bit mode or 18 in 16-bit extended mode) must be set to DMX value 30.
				⁽⁴⁾ To activate: Value must be held for 5 seconds Channel 14 in 16-bit/15 in 16-bit ext. must be set to DMX value 5 - 10 Channel 26 in 16-bit/29 in 16-bit ext. must be set to 55 - 59.

MSB = Most significant byte

LSB = Least significant byte

Control panel menus

Applicable when running firmware version 1.3.0

Commands marked * can also be executed via DMX

Menu level 1	Menu level 2	Menu level 3	Menu level 4	Notes (Default settings in bold print)	
SETUP WIZARD	Gives quick access to most frequently-used menus: FACTORY SETTINGS, DMX ADDRESS, PROTOCOL SET, FIXTURE ID plus most frequently-used PERSONALITY settings: PAN/TILT CONTROL, SPEED SETTINGS, FANS, DIMMING CURVE, AUTOMATICS LAMP ON, DISPLAY. See table below for details of these settings.				
DMX ADDRESS	1 – 486 (16-bit) 1 – 483 (16-bit ext.)	DMX address (new fixtures are supplied with address set to 1)			
PROTOCOL SET	16 Bit	16-bit basic DMX mode with 2-channel (coarse and fine) control of rotating gobo indexing or speed, pan, and tilt			
	16 Bit extended	16-bit extended DMX mode with basic mode features plus fine control of dimmer, rotating gobo indexing or speed, focus, zoom, pan and tilt			
FIXTURE ID	0000 – 9999	User-settable fixture ID number			
PERSONALITY	PAN/TILT SETTINGS	PAN/TILT CONTROL	Normal	Normal pan and tilt control	
			Swap	Map DMX pan control to tilt channel and vice versa	
			Pan invert	Reverse DMX pan control: right → left	
			Tilt invert	Reverse DMX tilt control: down → up	
			P/T limit	Enable pan and tilt range limits (see settings in P/T LIMIT SETTINGS menu)	
		MOVE ON RESET		Enable/disable pan/tilt movement when fixture resets. Default = On	
		PAN & TILT LIMIT SETTINGS	PAN MINIMUM	Set minimum pan angle (0° – 360°)	
			PAN MAXIMUM	Set maximum pan angle (360° – 0°)	
			TILT MINIMUM	Set minimum tilt angle (-134° – 134°)	
			TILT MAXIMUM	Set maximum tilt angle (134° – -134°)	
			P/T LIMIT AREA	Set pan/tilt to stay inside safe zone or stay outside no-go zone (Inside/Outside)	
			DEFAULT LIMIT SETTINGS?	Reset all pan and tilt limit settings to factory defaults.	
	SPEED SETTINGS	PAN & TILT SPEED	Normal	Normal speed pan and tilt	
			Fast	Optimize pan/tilt movement for speed	
			Slow	Optimize pan/tilt movement for smoothness	
		EFFECT SPEED	Follow P/T speed	Effects speed follows the speed setting applied to pan and tilt via DMX or in control menu	
			Normal	Normal effects speed	
			Fast	Optimize effects movement for speed	
Slow			Optimize effects movement for smoothness		

Table 2: Control menus

Menu level 1	Menu level 2	Menu level 3	Menu level 4	Notes (Default settings in bold print)
PERSONALITY (continued)	FANS	LAMP COOLING	50%	Sets lamp cooling fans to 50% capacity (color temperature of light output from the lamp is different at different thermal lamp temperatures)
			80%	Sets lamp cooling fans to 80% capacity
		FAN CLEAN	Off	Sets all cooling fans to no cleaning
			Auto	Fan cleaning mode activated automatically if fan error reported
			Forced	Sets all cooling fans to run at 100%)
		FAN MODE	Always on	Cooling fans operate constantly
	Follow lamp off		Cooling fans stop when lamp is powered off	
	DIMMING CURVE	Optical linear		Optically linear dimming curve
		VRMS linear		S-curve (fixture emulates incandescent lamp voltage linear RMS dimming curve)
		Square law		Square law dimming curve
		Inv.sq.law		Inverse square law dimming curve
	FOCUS TRACKING	Disabled		Disables zoom focus linking
		Near		Enables zoom focus linking, optimized for short-throw projection (5 - 10 m)
		Medium		Enables zoom focus linking, optimized for medium-throw projection (10 - 20 m)
		Far distance		Enables zoom focus linking, optimized for long-throw projection (20+ m)
	FOLLOWSPOT MODE	Followspot mode	OFF / ON	Enables/disables followspot mode (see "Followspot" on page 24). In followspot mode DMX control of pan and tilt is disabled and the pan and tilt motors are disengaged so the head can be freely moved using a followspot handle.
		Lock /unlock pan & tilt		Engages or disengages both the pan and tilt motors acting as a brake on head movement. DMX control over pan is still disabled and this is only available when followspot mode is on.
		Lock pan	OFF / ON	Will engage (ON) the pan motor to acts as a brake on head movement, or disengage (OFF) it so the head can be freely panned using a followspot handle. DMX control over pan is still disabled and this is only available when followspot mode is on.
		Lock tilt	OFF / ON	Will engage (ON) the tilt motor to acts as a brake on head movement, or disengage (OFF) it so the head can be freely tilted using a followspot handle. DMX control over tilt is still disabled and this is only available when followspot mode is on.
	AUTOMATIC LAMP ON	Off		Automatic lamp striking disabled
		On		Lamp strikes automatically within 90 seconds of fixture being powered on
		DMX		Lamp strikes automatically when the fixture receives a DMX signal
	DMX LAMP OFF	Off		Lamp cannot be powered off via DMX (can be overridden: see DMX protocol)
		On		Lamp can be powered off via DMX
	DMX RESET	Off		Fixture cannot be reset via DMX (can be overridden: see DMX protocol)
		On		Fixture can be reset via DMX
	PARAMETER SHORTCUTS	Off		Effects avoid open positions during effects changes
On			Effects take shortest route during changes, crossing open positions if necessary.	
DISPLAY	On		Display permanently on	
	2 min.		Display goes into sleep mode 2 minutes after last key press	
	5 min.		Display goes into sleep mode 5 minutes after last key press	

Menu level 1	Menu level 2	Menu level 3	Menu level 4	Notes (Default settings in bold print)
PERSONALITY (continued)	ERROR MODE	Normal		Enable error messages and warnings in display
		Silent		Disable error messages and warnings in display (the LED in the jog wheel will still light to indicate fixture status if an error has been detected or the fixture has a warning)
FACTORY SETTINGS	LOAD FACTORY SETTINGS			Return all settings (except calibrations) to factory defaults
FIXTURE INFORMATION	FIRMWARE VERSION	Vxx.xx.xx		Fixture software version
	POWER ON TIME	TOTAL POWER ON		Display hours fixture has been powered on since manufacture (not user-resettable)
		RESETTABLE POWER ON		Display hours fixture has been powered on since last counter reset (user-resettable)
		CLEAR RESETTABLE POWER ON		Reset RESETTABLE POWER ON counter to zero.
	LAMP ON TIME	TOTAL LAMP ON		Display hours of lamp use since manufacture (not user-resettable)
		RESETTABLE LAMP ON		Display hours of lamp use since last counter reset (user-resettable)
		CLEAR RESETTABLE LAMP ON		Reset RESETTABLE LAMP ON counter to zero.
	LAMP STRIKES	TOTAL LAMP STRIKES		Display number of times lamp has been struck since manufacture (not user-resettable)
		RESETTABLE LAMP STRIKES		Display number of times lamp has been struck since last counter reset (user-resettable)
		CLEAR RESETTABLE LAMP STRIKES		Reset RESETTABLE LAMP STRIKES counter to zero.
	AIR FILTERS	RESETTABLE AIR FILTER		Display hours fixture has been powered on since timer was last cleared.
		SET TIME ALERT		Set alert timer from 0 - 750 hours.
		CLEAR RESETTABLE AIR FILTER		Resets AIR FILTER timer to zero.
	FIXTURE MAC ID	xx.xx.xx.xx.xx.xx		Fixture's MAC address
	RDM UID	xxxx.xxxxxxxx		Fixture's unique RDM ID
	FAN SPEED			Displays speed in RPM of all cooling fans
	TEMPERATURE			Displays temperature in °C of all PCBs and of ballast capacitor
POWER UNIT			Displays voltage at mains power input, voltage, current and wattage at lamp terminals, lamp status, igniter status and lamp intensity.	
DMX LIVE	RATE		DMX transmission speed in packets per second	
	QUALITY		Percent of packets received	
	START CODE		Value of the DMX start code	
	STROBE/SHUTTER → FIXTURE ADJUSTMENTS		DMX value (0 - 255) received on each channel Values for fine control channels can only be viewed if available in the DMX mode the fixture is set to	
TEST SEQUENCE	ACTION	Start / Stop / Pause	Run test sequence of all functions	
	REPEAT	On / Off	Enable auto-repeat of test sequence	
	STATUS → DURATION		Scene status information for test sequence	

Table 2: Control menus

Menu level 1	Menu level 2	Menu level 3	Menu level 4	Notes (Default settings in bold print)
MANUAL CONTROL	RESET	ACTION		Click jog wheel to reset fixture
	LAMP ON/OFF	ACTION		Manually strike/douse lamp
	STROBE/SHUTTER	0-100% (000-255)		Set shutter opening
	DIMMER	0-100% (000-255)		Set dimmer opening
	CYAN	0-100% (000-255)		Add cyan
	MAGENTA	0-100% (000-255)		Add magenta
	YELLOW	0-100% (000-255)		Add yellow
	CTC	0-100% (000-255)		Add color temperature control (add warmth)
	COLOR	0-100% (000-255)		Select color filter
	GOBO 1	0-100% (000-255)		Select gobo, gobo wheel 1
	GOBO 1 S/I	0-100% (000-255)		Adjust gobo speed/indexing, gobo wheel 1
	GOBO 2	0-100% (000-255)		Select gobo, gobo wheel 2
	GOBO 2 S/I	0-100% (000-255)		Adjust gobo speed/indexing, gobo wheel 2
	MACRO	0-100% (000-255)		Select macro
	GOBO ANI POSITION	0-100% (000-255)		Set gobo animation wheel position
	GOBO ANI INDEX	0-100% (000-255)		Set gobo animation wheel indexing
	BEAM EFFECT INDEX	0-100% (000-255)		Set beam effect (rotating prism) indexing
	IRIS	0-100% (000-255)		Set iris aperture
	FOCUS	0-100% (000-255)		Set focus
	ZOOM	0-100% (000-255)		Set zoom
PAN	0-100% (000-255)		Set pan angle	
TILT	0-100% (000-255)		Set tilt angle	
SERVICE	PAN/TILT FEEDBACK	On		Enable pan/tilt position feedback systems
		Off		Disable pan/tilt position feedback
	ADJUST	CMY MODULE	DIMMER	For use by qualified service technicians – see Martin service documentation before entering this menu
		EFFECT MODULE	SHUTTER	
		PAN/TILT MODULE	PAN	
	TILT			
	CALIBRATION	PAN/TILT SENSOR CALIBRATION	PAN/TILT AT END STOP	Move pan and tilt to end stops following instructions in the display, then execute to calibrate pan and tilt sensors
		DIMMER ... TILT		Set individual effects to calibration positions (approx. +/- 5% offset available)
		LOAD DEFAULTS?		Load factory default calibration settings
		SAVE FACTORY DEFAULT?		Replace factory default calibration settings with current calibration settings
UPDATE FIRMWARE	UPDATE		Execute to update fixture firmware from bank shown in display	
	BANK		Firmware bank version	
	LOCATION		Location of firmware bank	

Table 2: Control menus

Service and display messages

The MAC III Profile gives service and maintenance information by displaying a large 3- or 4-character short code and a smaller full-text message in the display. The short code is visible at a distance, allowing error identification with the fixture still in the rig, for example, while the full-text message gives more detailed information about the error.

Service warnings

If the MAC III Profile requires service, it displays a warning indicating the service required. The most important short codes and messages are given in Table 3 below:

Short code	Full-text message
LLW	LAMP LIFE WARNING Lamp life is within 10% of its limit.
AIRS	AIR FILTER SERVICE WARNING (s/w versions from ver. 1.3) The timer available in the SERVICE menu has reached the point for which the alarm was set.
AFSW	AIR FILTER SERVICE WARNING (s/w versions prior to ver. 1.3) The timer available in the SERVICE menu has reached the point for which the alarm was set.

Table 3: Service warning messages

Error messages

The MAC III Profile monitors its own operation. If it detects an error, it displays an error warning. The most important short codes and messages are given in Table 4 below:

Short code	Full-text message
APER	ANIMATION WHEEL POSITION ERROR
ARER	ANIMATION WHEEL ROTATION ERROR
BANK	UNABLE TO UNPACK BANK Error unpacking firmware during/after software reload
BATM	BATTERY MODE Switched to battery power source with limited functionality. Plug in power cable to restore full function operation.
BEER	BEAM SHAPER ERROR
BOTV	BOOTLOADER(S) VERSION NOT VALID Decentralized firmware in module cannot be replaced / does not match bank. Module or module bootloader replacement required.
BRER	BEAM SHAPER ROTATION ERROR
BT W	BASE TEMPERATURE TOO HIGH At least one base PCB temperature >75°C
BTCO	BASE TEMPERATURE CUTOFF At least one base PCB temperature >85°C
BTER	BASE TEMP HIGH The temperature on a PCB in the base is high. A fan might be defective or the ambient temperature may be too high.
C1ER	COLOR WHEEL 1 ERROR
CCDE	CMY CALIBRATE DATA PCB (s/w versions prior to ver. 1.3) Unable to read/write data to external EEPROM board (calibrate date) on CMY module
CDCM	CALIBRATE DATA CMY Unable to read/write data to external EEPROM board (Calibrate Data) on CMY module. The PCB needs to be replaced.
CDEF	CALIBRATE DATA EFFECT Unable to read/write data to external EEPROM board (Calibrate Data) on Effect module. The PCB needs to be replaced.

Table 4: Error messages

Short code	Full-text message
CDPT	CALIBRATE DATA PAN/TILT Unable to read/write data to external eeprom board (Calibrate Data) on Yoke. The PCB needs to be replaced.
CDZF	CALIBRATE DATA ZOOM/FOCUS Unable to read/write data to external eeprom board (Calibrate Data) on Zoom/Focus module. The cables need to be checked or the module may need to be replaced.
CECH	COM ERROR CHARGER Unable to read/write data to external eeprom board (Calibrate Data) on the charger. The cables need to be checked or the module may need to be replaced.
CEPU	COM ERROR POWER UNIT I2C communication between main controller and ballast failed. The cables need to be checked or the module may need to be replaced.
CEUI	COM ERROR UI User interface communication failure. The cables need to be checked or the module may need to be replaced.
COLD	FIXTURE IS COLD PCBs are below 20° C
CONC	COOLING NO CONNECTION (s/w versions prior to ver. 1.3)
CONE	EFFECT NO CONNECTION (s/w versions prior to ver. 1.3)
CONM	CMY NO CONNECTION (s/w versions prior to ver. 1.3)
CONP	PAN/TILT NO CONNECTION (s/w versions prior to ver. 1.3)
CONZ	ZOOM/FOCUS NO CONNECTION (s/w versions prior to ver. 1.3)
CTER	CTC ERROR The sensors, wiring and motor need to be checked and the driver PCB may need to be replaced.
CYER	CYAN ERROR The sensors, wiring and motor need to be checked and the driver PCB may need to be replaced.
DIER	DIMMER ERROR The sensors, wiring and motor need to be checked and the driver PCB may need to be replaced.
DINA	DIMMER NOT ADJUSTED Dimmers need to be adjusted by a qualified service technician.
ECDE	EFFECT CALIBRATE DATA PCB (s/w versions prior to ver. 1.3) Unable to read/write data to external EEPROM board (calibrate date) on effect module
EEDF	WRITING EEPROM DEFAULT(S) No valid EEPROM in a CAN module. Writing default into the EEPROM based on the CAN address. Module is possibly incorrectly connected
EEPR	EEPROM INVALID/NO CONN. No connection or EEPROM data invalid
EFSM	ERROR FAILSAFE MODE Module error detected during self-check at startup. Service intervention required. Fixture control possibly disabled, depending on nature of error.
FAN	LAMP FAN 1 ERROR
FAN	LAMP FAN 2 ERROR
FAN	EFFECT FAN 1 ERROR
FAN	EFFECT FAN 2 ERROR
FAN	EFFECT FAN 3 ERROR
FAN	BASE FAN 1ERROR
FAN	POWER FAN 1 ERROR
FAN	POWER FAN 2 ERROR
FBEP	PAN FEEDBACK ERROR Unable to correct pan position
FBET	TILT FEEDBACK ERROR Unable to correct tilt position
FOER	FOCUS ERROR

Table 4: Error messages

Short code	Full-text message
FUSB	FORCED USB UPLOAD ENABLED The fixture has been started in forced upload mode (the Escape button was held during power up).
G11M	GOBO WHEEL 1 GOBO 1 MISSING The gobo is not installed, faulty, or operating in extremely cold temperatures. Instal, replace or allow the gobo to warm up.
G12M	GOBO WHEEL 1 GOBO 2 MISSING The gobo is not installed, faulty, or operating in extremely cold temperatures. Instal, replace or allow the gobo to warm up.
G13M	GOBO WHEEL 1 GOBO 3 MISSING The gobo is not installed, faulty, or operating in extremely cold temperatures. Instal, replace or allow the gobo to warm up.
G14M	GOBO WHEEL 1 GOBO 4 MISSING The gobo is not installed, faulty, or operating in extremely cold temperatures. Instal, replace or allow the gobo to warm up.
G15M	GOBO WHEEL 1 GOBO 5 MISSING The gobo is not installed, faulty, or operating in extremely cold temperatures. Instal, replace or allow the gobo to warm up.
G1ER	GOBO WHEEL 1 ERROR
G21M	GOBO WHEEL 2 GOBO 1 MISSING The gobo is not installed, faulty, or operating in extremely cold temperatures. Instal, replace or allow the gobo to warm up.
G22M	GOBO WHEEL 2 GOBO 2 MISSING The gobo is not installed, faulty, or operating in extremely cold temperatures. Instal, replace or allow the gobo to warm up.
G23M	GOBO WHEEL 2 GOBO 3 MISSING The gobo is not installed, faulty, or operating in extremely cold temperatures. Instal, replace or allow the gobo to warm up.
G24M	GOBO WHEEL 2 GOBO 4 MISSING The gobo is not installed, faulty, or operating in extremely cold temperatures. Instal, replace or allow the gobo to warm up.
G25M	GOBO WHEEL 2 GOBO 5 MISSING The gobo is not installed, faulty, or operating in extremely cold temperatures. Instal, replace or allow the gobo to warm up.
G2ER	GOBO WHEEL 2 ERROR
GOER	GOBO WHEEL ERROR The sensors, wiring and motor need to be checked and the driver PCB may need to be replaced.
HOT	LAMP TOO HOT TO RESTRIKE The fixture will attempt to restrike at 20 second intervals. After 90 seconds if the lamp still refuses to strike, LERR is displayed
HT W	HEAD TEMPERATURE TOO HIGH One or more of the PCB's in the head is above 85 degrees celsius. Power off the fixture, allow it to cool, and restart.
HTCO	HEAD TEMP CUT OFF One or more of the PCB's in the head is above 95 degrees celsius. Power off the fixture, allow it to cool, and restart.
HTER	HEAD TEMP HIGH The temperature on a PCB in the head is high. A fan might be defective or the ambient temperature may be too high.
IRER	IRIS ERROR
LERR	LAMP ERROR The lamp is defective or has exploded, is missing, or the lamp cannot restrike after 90 seconds.
LLW	LAMP LIFE Lamp on counter has timed out and it is time to change the lamp. The counter must be reset once this is done. See "Fixture information readouts" on page 19.
LSER	LAMP SENSING CIRCUIT ERROR (s/w versions from ver. 1.3) Lamp sensing circuit reports that lamp should be on but is not actually on.
LSRR	LAMP SENSING CIRCUIT ERROR (s/w versions prior to ver. 1.3) Lamp sensing circuit reports that lamp should be on but is not actually on.
MAER	MAGENTA ERROR
MALE	MAINS LOW The input voltage on the ballast is too low to strike the lamp.
MALW	MAINS LOW Mains voltage is below acceptable level. The lamp may not be able to strike.
PAER	PAN ERROR

Table 4: Error messages

Short code	Full-text message
PANA	PAN NOT ADJUSTED Pan needs to be adjusted by a qualified service technician.
PCDE	PAN/TILT CALIBRATE DATA PCB (s/w versions prior to ver. 1.3) Unable to read/write data to external EEPROM board (calibrate date) on yoke
PSER	PAN SENSOR ERROR
PTCM	PAN/TILT SENSOR CAL MISSING The pan/tilt sensors are not calibrated.
PTCO	PSU TEMP CUTOFF Ballast in thermal cutoff
PTCS	PAN/TILT CALIBRATE SENSOR (s/w versions prior to ver. 1.3) Pan/tilt sensors not calibrated
PTER	PSU TEMP HIGH The temperature on a PCB in the power supply unit or ballast is high. A fan might be defective or the ambient temperature may be too high.
R1ER	GOBO WHEEL 1 ROTATION ERROR
R2ER	GOBO WHEEL 2 ROTATION ERROR
SHER	SHUTTER ERROR
SHNA	SHUTTER NOT ADJUSTED No shutter adjustment data in EEPROM
SLER	SAFETY LOOP ERROR Lamp safety loop circuit activated: the lamp access hatch is open or lamp is too hot
SSTO	SYSTEM STATE TIMEOUT Failure to communicate with module during self-check at startup. Service intervention required. Fixture control possibly disabled, depending on nature of error.
TIER	TILT ERROR
TINA	TILT NOT ADJUSTED Tilt needs to be adjusted by a qualified service technician.
TSER	TILT SENSOR ERROR
UECH	UPLOAD ERROR CHARGER Could not upload new firmware to the Charger module.
UECM	UPLOAD ERROR CMY Could not upload new firmware to the CMY module.
UECO	UPLOAD ERROR COOLING Could not upload new firmware to the Cooling module.
UEEF	UPLOAD ERROR EFFECT Could not upload new firmware to the Effects module.
UEPT	UPLOAD ERROR PAN/TILT Could not upload new firmware to the Pan/Tilt Focus module.
UEPU	UPLOAD ERROR POWER UNIT Could not upload new firmware to the Power Unit module.
UEUI	UPLOAD ERROR UI Could not upload new firmware to the User Interface module.
UEZF	UPLOAD ERROR ZOOM/FOCUS Could not upload new firmware to the Zoom Focus module.
UPLB	UPLOAD ERROR ON BALLAST (s/w versions prior to ver. 1.3)
UPLC	UPLOAD ERROR ON COOLING (s/w versions prior to ver. 1.3)
UPLD	DMX UPLOAD ERROR An error occurred during upload via DMX. Check cabling and connections, and then restart.
UPLE	UPLOAD ERROR ON EFFECT (s/w versions prior to ver. 1.3)
UPLM	UPLOAD ERROR ON CMY (s/w versions prior to ver. 1.3)
UPLP	UPLOAD ERROR ON PAN/TILT (s/w versions prior to ver. 1.3)
UPLU	UPLOAD ERROR ON USER INTERFACE (s/w versions prior to ver. 1.3)
UPLZ	UPLOAD ERROR ON ZOOM/FOCUS (s/w versions prior to ver. 1.3)
YEER	YELLOW ERROR
YT W	YOKE TEMPERATURE TOO HIGH Yoke PCB temperature > 85° C

Table 4: Error messages

Short code	Full-text message
YTER	YOKE TEMP HIGH The temperature on a PCB in the yoke is high. A fan might be defective or the ambient temperature may be too high.
YTCO	YOKE TEMPERATURE CUTOFF Yoke PCB temperature > 95° C
ZCDE	ZOOM CALIBRATE DATA PCB (s/w versions prior to ver. 1.3) Unable to read/write data to external EEPROM board (calibrate date) on zoom/focus module
ZOER	ZOOM ERROR

Table 4: Error messages

Troubleshooting

Problem	Probable cause(s)	Remedy
One or more of the fixtures is completely dead.	No power to fixture.	Check that power is switched on and cables are plugged in.
	Primary fuse blown (located near mains inlet).	Isolate fixture from power and replace fuse.
	Secondary fuse(s) blown (located on PCBs in base).	Isolate fixture from power. Check fuses and replace.
Fixtures reset correctly but respond erratically or not at all to the controller.	Bad data link.	Inspect connections and cables. Correct poor connections. Repair or replace damaged cables.
	Data link not terminated.	Insert DMX termination plug in data output socket of the last MAC III Profile on the data link.
	Incorrect addressing of fixtures.	Check fixture address and protocol settings.
	One of the fixtures is defective and disturbs data transmission on the link.	Unplug the XLR in and out connectors and connect them directly together to bypass one fixture at a time until normal operation is regained. Have the fixture serviced by a qualified technician.
	DMX and RDM ports switched	Check that data port settings match desired pinout at XLR connectors
Time out error after fixture reset.	Effect requires mechanical adjustment.	Contact Martin technician for service.
Mechanical effect loses position.	Mechanical train requires cleaning, adjustment, or lubrication.	Contact Martin technician for service.
No light and lamp error message displayed.	Lamp blown	Disconnect fixture and replace lamp.
	Lamp not installed	Disconnect fixture and install lamp.
	Lamp access door safety switch open	Verify that lamp access door is fully seated and locked in place.
Lamp cuts out intermittently.	Fixture is too hot.	Allow fixture to cool. Clean fixture. Reduce ambient temperature.

Table 5: Troubleshooting

Specifications

Physical

Length	690 mm (27.2 in.)
Width	536 mm (21.1 in.)
Height (head straight up)	914 mm (36.0 in.)
Weight	53.5 kg (117.9 lbs.)

Lamp

Type	1500 W short arc discharge
Approved lamp	Osram HTI 1500W/60/P50
Color temperature	6000 K
CRI (Color rendering index)	>85
Average lifetime	750 hours
Hot restrike	Semi-hot
Socket	PGJ50
Ballast	Electronic

Dynamic Effects

Color mixing	CMY, independently variable 0 - 100%
Color temperature control	CTO, variable 0 - 100%
Color wheel	7 interchangeable dichroic filters + open, indexing, continuous rotation, random color
Rotating gobo wheel	Two rotating gobo wheels, each with 5 interchangeable rotating gobos + open, indexing, continuous gobo rotation, shake
Gobo animation	Interchangeable animation wheel, indexing, continuous rotation with variable angle, speed and direction
Prism	Interchangeable 4-facet rotating prism
Iris	0 - 100%, pulse effects
Mechanical dimmer	0 - 100%
Mechanical shutter	Strobe effect 2 - 10 Hz, pulse effects, instant open and blackout
Focus	2 m to infinity
Zoom	11.5° - 55°
Pan	540°
Tilt	268°
Position correction system	Absolute position monitoring

Control and programming

DMX channels	27/30
Setting and addressing	Control panel with backlit graphic display
16-bit control	Dimmer, gobo indexing (gobo wheels 1 and 2), focus, zoom, pan and tilt
Protocol	USITT DMX512-A
Fixture identification	Four-digit user-settable ID number
Receiver	Opto-isolated RS-485
Firmware update	USB memory device

Photometric data

Standard lens, zoom at minimum

Efficiency	22%
One tenth-peak angle	11°
Total output	31500 lm

Standard lens, zoom at median

Efficiency	23%
One tenth-peak angle	32°
Total output	33300 lm

Standard lens, zoom at maximum

Efficiency	23%
One tenth-peak angle	53°
Total output	33800 lm

Measurement source: Osram HTI 1500W/60/P50

Measurement conditions: 227 V, 50 Hz, no effects applied

Construction

Color	Black
Housing	Magnesium alloy, UV-resistant fiber-reinforced composite
Reflector	Glass, cold light
Protection rating	IP20

Gobos

Size	E
Outside diameter	37.5 mm (1.5 in.) +/- 0.2 mm (0.01 in.)
Maximum image diameter	30 mm (1.2 in.) +/- 0.4 mm (0.02 in.)
Maximum thickness	1.1 mm (0.04 in.) +/- 0.1 mm (0.004 in.)
Recommended glass	Borosilicate 3.3 or better with dichroic or heavy matted aluminum coating

Gobo animation wheel

Outside diameter	133.9 mm (5.3 in.) +/- 0.1 mm (0.004 in.)
Image outer diameter	130 mm (5.1 in.)
Image inner diameter	32 mm (1.3 in.)
Thickness	1.1 mm (0.04 in.) +/- 0.1 mm (0.004 in.)
Recommended glass	Borosilicate 3.3 or better with dichroic or normal/double mirror aluminum coating

Installation

Mounting points	2 pairs of 1/4-turn locks
Orientation	any
Minimum distance from illuminated surface	2.5 m (100 in.)
Minimum distance from combustible materials	0.2 m (8 in.)

Connections

AC power input	Neutrik PowerCon connector with 3 m (9.8 ft.) cable tail
DMX and RDM data in/out	5-pin locking XLR
Ethernet (Artnet II compatible, ACN-ready)	Neutrik RJ-45 socket (accepts Neutrik EtherCon connectors in housing)
USB devices (including USB memory storage)	USB host socket
Future USB options	USB device socket

Electrical

AC input	3 m trailing cable w/o cord cap
AC power	200-240 V nominal, 50/60 Hz
Power supply	auto-ranging electronic switch-mode
Main fuse for 200 - 240 V power	16 AT (x 2)

Typical power and current

200 V, 50 Hz	1801 W, 9.0 A, PF 0.996
200 V, 60 Hz	1805 W, 9.1 A, PF 0.995
208 V, 60 Hz	1802 W, 8.8 A, PF 0.994
220 V, 50 Hz	1788 W, 8.2 A, PF 0.994
230 V, 50 Hz	1783 W, 7.8 A, PF 0.993
240 V, 50 Hz	1779 W, 7.5 A, PF 0.989
240 V, 60 Hz	1786 W, 7.5 A, PF 0.987

Measurements made at nominal voltage. Allow for a deviation of +/- 10%.

PF = power factor

Thermal

Maximum ambient temperature (T_a)	40° C (104° F)
Maximum surface temperature, steady state, $T_a = 40° C$	170° C (338° F)
Cooling	Filtered forced air (temperature-regulated, low noise)
Total heat dissipation (calculated, +/- 10% at 200 V, 60 Hz)	6160 BTU/hr

Approvals



EU EMC	EN 55 103-1, EN 55 015, EN 61 547
EU safety	EN 60598-2-17
US safety	ANSI/UL 1573
Canadian safety	CSA C22.2 No. 166

Included items

Osram HTI 1500W/60/P50 lamp	P/N 97010326
3 m (9.8 ft.) 12 AWG, SJT power cable with Neutrik PowerCon NAC3FCA cable connector	P/N 11541503
Dichroic color filters	7 (installed)
Gobos	10 (installed)
Tribal waves gobo animation wheel (installed)	P/N 62325143
2 omega clamp attachment brackets with quarter-turn fasteners	2 x P/N 91602001
User manual	P/N 35000214

Accessories

Half-coupler clamp	P/N 91602005
G-clamp (suspension with yoke vertically downwards only)	P/N 91602003
Quick-trigger clamp (suspension with yoke vertically downwards only)	P/N 91602007

Spare parts

Osram HTI 1500W/60/P50 lamp	P/N 97010326
Neutrik PowerCon NAC3FCA cable connector for power cable	P/N 05342804
16 AT (slow blow) fuse	P/N 05020047

Related Items

Martin DABS1™ USB-XLR interface device and cables	P/N 91611144
Martin Universal USB-DMX Interface Box™	P/N 90702045

Ordering information

MAC III Profile in cardboard packing case	P/N 90206000
MAC III Profile in flight case	P/N 90206001

Intellectual Property Rights

MAC III™ products are covered by one or more of these patents:

DE 60,009,334; EP 1,234,197; US 6,241,366; US 6,687,063; US 6,601,973; US 6,971,770; US 7,222,997

and/or one or more of these patent applications:

CN 1985125A; CN 200810128720.0; CN 200810128782.1; CN 200810128771.3; CN 200810128776.6; CN 200810131481.4; CN 200810125884.8; CN 200810125883.3; EP 1,747,399A1; EP 08103667.5; EP 08103669.1; EP 08103671.7; EP 08103673.3; EP 08103672.5; EP 08103784.8; EP 08103674.1; EP 08158378.3; EP 08104332.5; US 2008/0089066; US 2007/0145937; US 12/058,138; US 12/107,821; US 12/107,827; US 12/107,826; US 12/107,833; US 12/107,837; US 12/112,078; US 12/136,365; US 12/140,494

and/or one or more other intellectual property rights, including one or more intellectual property rights listed on www.martin.com/ipr

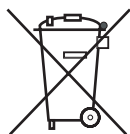

Disposing of this product

Martin™ products are supplied in compliance with Directive 2002/96/EC of the European Parliament and of the Council of the European Union on WEEE (Waste Electrical and Electronic Equipment), as amended by Directive 2003/108/EC, where applicable.

Help preserve the environment! Ensure that this product is recycled at the end of its life. Your supplier can give details of local arrangements for the disposal of Martin products.

This product contains two batteries. Ensure that they are disposed of responsibly by an authorized recycling or waste disposal center at the end of their life. Where applicable, Martin participates in schemes whose aim is to ensure that local recycling and/or waste disposal centers accept batteries from Martin products.

Martin[®]

www.martin.com • Olof Palmes Allé 18 • 8200 Aarhus N • Denmark
Tel: +45 8740 0000 • Fax +45 8740 0010