



Audio Structure for Rooms Made Easy

You work hard to pull resources together to conduct effective meetings and training sessions. So, why is it that often you are left feeling like your interactions are unproductive and participants walk away without fully understanding your message?

Have you considered enhancing the productivity in your meeting and training rooms by simply increasing the sound volume?

ListenPoint delivers the audio structure your room needs to raise the overall sound level of all your sound sources. You'll keep participants focused and engaged; your voice won't be strained from talking loudly, resulting in a productive and effective interaction for all.

ListenPoint Features & Benefits

- Provides complete audio infrastructure for rooms – integrates all your sound sources to be heard – DVD, computer, Mp3 player, teleconferencing, room microphones, and VOIP/Skype™ systems.
- Productivity accelerator – decreases costs, raises the overall sound level in any room, increasing retention, keeping participants focused and engaged, and reducing fatigue for both speakers and participants.
- Secure wireless microphones – can be used in multiple rooms without the threat of interference or incompatibility.
- Simple, intuitive operation makes it easy for anyone to use the system, with professional grade products designed for many years of continuous use.

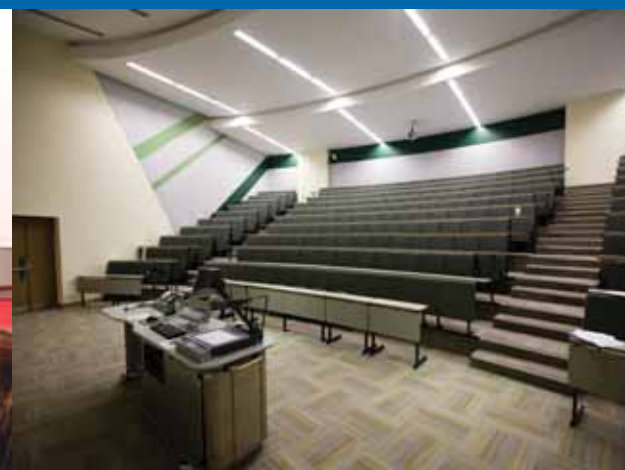

ListenPoint is an easy way to incorporate audio structure into a classroom, training facility, courtroom, hotel meeting rooms, multi-purpose rooms and much more. ListenPoint can be used as a simple sound system or can be interfaced with a Listen FM or IR assistive listening system, telephone conferencing equipment, computer for VOIP/Skype™ conference calls, external paging, third party control, and DVD player. ListenPoint offers so many options and is ideal for many venues including:

- Classrooms
- Business or Civic Meetings
- Employee Trainings
- Government Facilities
- Auditoriums
- Lecture Halls
- Control Rooms
- Secure Rooms
- Hotels
- Houses of Worship
- Overflow Areas
- Laboratories

“The Listenpoint System has been a real lifesaver for my voice, and my students pay more attention.”



listenpoint™ Core Components

ListenPoint Control Unit (CU)



Item	Item Name	Unbalanced Inputs	Balanced In/Outputs	Direct T-Con and Skype Interface	RS-232 Control	RS-232 Customization
LPT-C2	ListenPoint Standard Control Unit	Two (2)	None	No	No	Yes
LPT-C6	ListenPoint Advanced Control Unit	Four (4)	One (1) / One (1)	Yes	Yes	Yes

ListenPoint Room Module (RM)



Item	Item Name	Max # of Mics	Speaker Power	# of Cat-5e Cables Required	Remote Sensors
LPT-R2	ListenPoint Room Module (2 Mic Max/ No Power Amp.)	Two (2)	None	One (1)	Two (2)
LPT-R4	ListenPoint Room Module (4 Mic Max/ No Power Amp.)	Four (4)	None	One (1)	Two (2)
LPT-R12	ListenPoint Powered Room Module (2 Mic Max/ 60 Watts)	Two (2)	60 Watts RMS	One (1)	Two (2)
LPT-R14	ListenPoint Powered Room Module (4 Mic Max/ 60 Watts)	Four (4)	60 Watts RMS	One (1)	Two (2)
LPT-R22	ListenPoint High Powered Room Module (2 Mic Max/ 120 Watts)	Two (2)	120 Watts RMS	Two (2)	Two (2)
LPT-R24	ListenPoint High Powered Room Module (4 Mic Max/ 120 Watts)	Four (4)	120 Watts RMS	Two (2)	Two (2)

ListenPoint Speakers

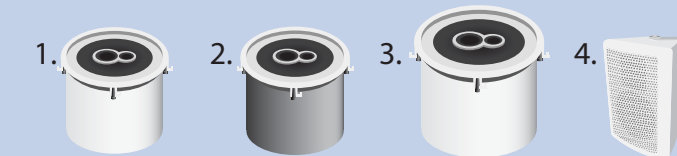

Item	Item Name	Item Name
1.	LPT-A104	6 in. (15 cm) Ceiling Speaker
2.	LPT-A104-P	6 in. (15 cm) Plenum Rated Ceiling Speaker
3.	LPT-A105	8 in. (20 cm) Ceiling Speaker
4.	LPT-A106	5 in. (13 cm) Wall Mount Speaker

ListenPoint M1 Microphone Kit



- M1 ListenPoint Microphone
- Charging/Storage Station
- Power Supply
- Handheld Sleeve
- Li-ion Battery
- Lanyard
- Four (4) Clips (2 Lanyard styles, Belt, Clothing)

4 ways to use the microphone

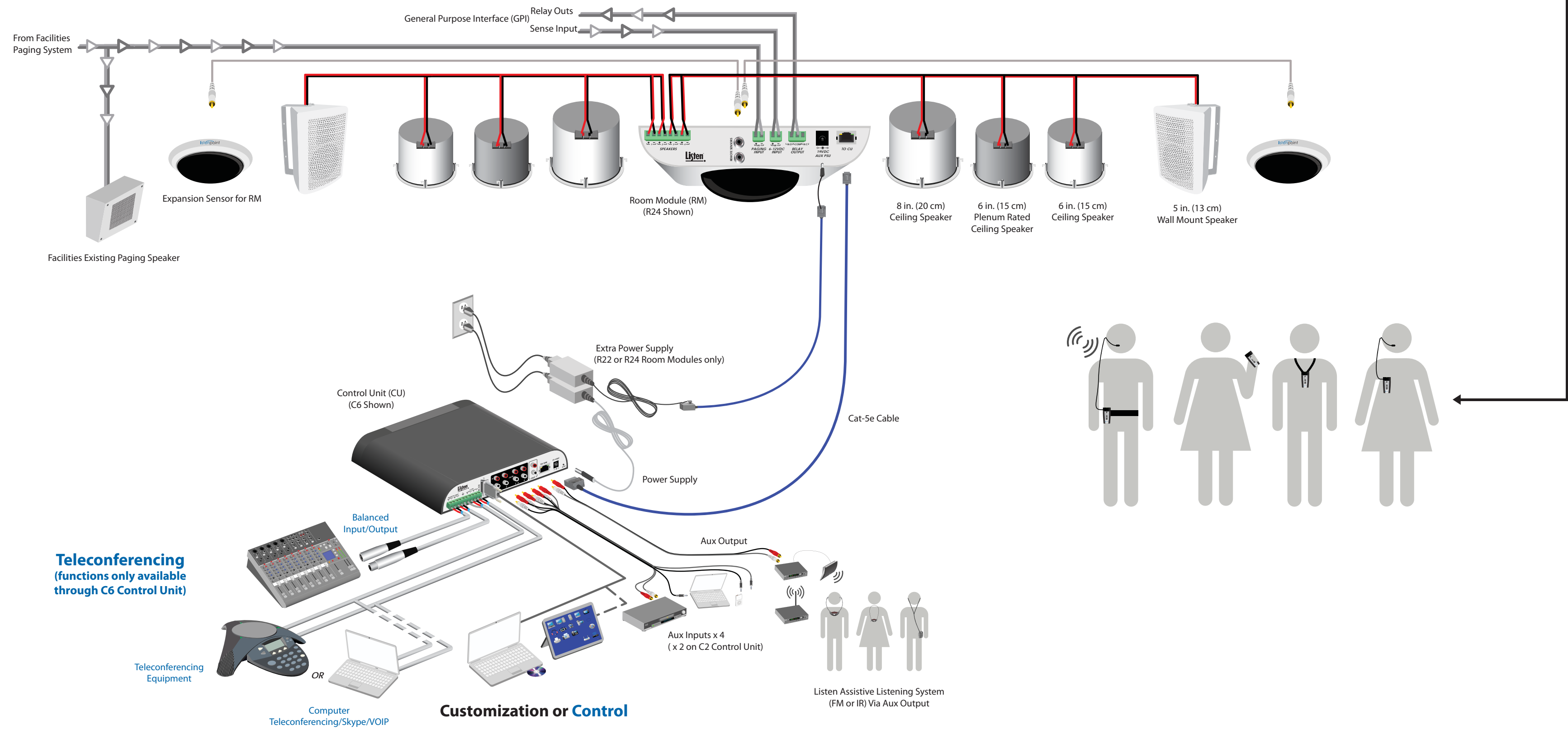

Teleconferencing
(functions only available through C6 Control Unit)

Teleconferencing Equipment

Computer Teleconferencing/Skype/VOIP

Customization or Control

Listen Assistive Listening System (FM or IR) Via Aux Output