

Model 212

Announcer's Console

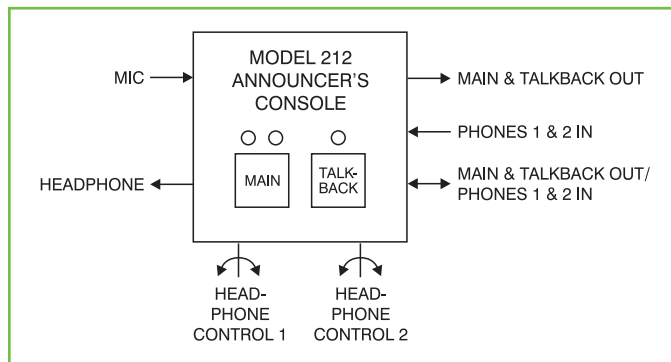

The Model 212 Announcer's Console is an audio control "hub" for announcers, commentators, and production personnel that features digital audio input and output resources. The broadcast-standard interfaces allow direct integration of the table-top unit into contemporary "all-digital" environments.



Key Features:

- Microphone preamp with selectable gain and 48 volt phantom power
- Two digital audio input channels
- Two pushbutton switches offer programmable "click-free" audio path control
- Digital audio main and talkback output channels
- Digital interfaces directly compatible with unbalanced AES digital audio signals
- Bidirectional digital interface for direct integration with Riedel® intercom systems
- Stereo headphone monitoring of selectable sources
- Two rotary headphone output level controls
- Microcontroller-directed audio routing
- All configuration switches accessible via the bottom of the enclosure

Flexible Setup

Two pushbutton switches—Main and Talkback—operate under microprocessor control to offer unmatched flexibility and "click-free" audio routing. The Main button controls the main output audio channel with operating modes that include push-to-mute (cough), push-to-talk, and latching. The Talkback button controls an audio channel that provides talent-oriented cue signals to production personnel. Both channels are formatted into an AES digital audio "stream" that is routed to two BNC interfaces: an AES3id-compliant output and a bidirectional digital interface for direct integration with Riedel intercom systems. For non-on-air applications a special feature set referred to as "production" mode can be enabled. Simple customization of the button labels ensures the user is presented with an easy-to-use set of controls and indicators.

Superior Audio

Featuring a studio-inspired low-noise/low-distortion preamplifier design, adjustable gain, and 48 volt phantom power, the Model 212 is compatible with balanced dynamic and condenser microphones. A sophisticated compressor circuit controls the dynamic range of the audio signal from the microphone preamplifier to ensure the main output offers faultless performance as the on-air or other primary audio feed.

Powerful Monitoring

The headphone output's circuitry provides high output levels with very low distortion and noise. The user can monitor audio channels from among the three digital audio sources: the AES3id input, the bidirectional digital interface, and an optionally implemented AES3 input. Each source can be individually assigned to the left, right, or both channels of the binaural headphone output. Two rotary controls allow the user to adjust the headphone output levels.

Speedy Configuration

Model 212 configurations are made using DIP-type switches that are accessible via the bottom of the enclosure. No disassembly is required. An included security panel attaches to the bottom of the enclosure to limit access.

Installer Friendly

The Model 212 is powered by the supplied external 24 volt DC source. Audio inputs and outputs utilize industry-standard connections—XLR for the microphone and 75 ohm BNC for the digital inputs and outputs. Two spare connector locations are available on the Model 212's back panel. Factory-available assemblies and card kits allow a technician to customize these spare locations to accept a 6- or 7-pin XLR-type headset or to bring remote switch inputs to an XLR connector. Additional card kits include balanced 110 ohm (AES3) digital input or output connections, direct microphone output, and line-level input. The optional rack-mounted Model 44 Interface can provide power and signal routing over Ethernet-style interface cables to up to six Model 212 units (EtherCon® Connector Card Kit required).

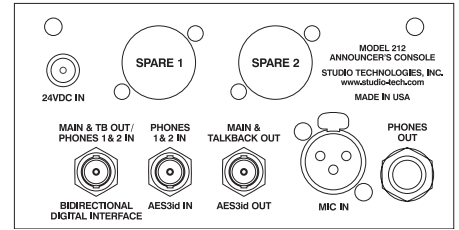

Model 212 Back Panel

Specifications

General Audio:

Frequency Response: < -0.1 dB at 20 Hz, -1 dB at 18 kHz, mic in/main out
 Distortion (THD+N): 0.025%, measured at 1 kHz, mic in/main out
 S/N Ratio: 71 dB, referenced to -46 dBu mic in/-14 dBFS out
 Common Mode Rejection Ratio: 68 dB at 60 Hz

Connectors:

Mic In: 3-pin female XLR-type
 AES3id Out, AES3id In, Bidirectional Interface: 75 ohm BNC
 Headphone Out: ¼-inch 3-conductor phone jack
 24 Vdc Power In: 2.1 x 5.5 mm coaxial power jack
Spare Connector Locations: 2
 Allows one or two Neutrik NC*D-L-1 connectors to be installed (*=3F, 3M, 5F, 5M, 6F, 6S, etc.)

Digital Inputs/Outputs:

A/D, D/A Converters: 24 bit, 100 dB dynamic range
 Sampling Rate: internal clock source 48 kHz, external clock source 32 to 96 kHz
 AES3id In: unbalanced, transformer-coupled
 Impedance: 75 ohms
 AES3id Out: unbalanced, transformer-coupled
 Impedance: 75 ohms
 Bidirectional: unbalanced transformer-coupled
 Impedance: 75 ohms
 AES3 In: balanced, transformer-coupled (via optional connector)
 Impedance: 110 ohms
 AES3 Out: balanced, transformer-coupled (via optional connector)
 Impedance: 110 ohms

Microphone Input/Preamplifier:

Type: electronically balanced
 Input Impedance: 2 k ohms, nominal
 Gain Range: 10 to 50 dB, nominal, adjustable in 10 dB steps
 Compatibility: dynamic or phantom-powered mics
 Phantom Power: 48 Vdc, nominal, meets IEC 61938

Compressor:

Threshold: switchable -14 dBFS/-4 dBFS
 Attack/Release Time: 2 mSec/100 mSec, nominal
 Slope: 5:1, nominal

Optional Line Inputs: 2

Type: balanced, transformer-coupled
 Impedance: 10 k ohms, nominal
 Nominal Level: +4 dBu

Headphone Output: 1, binaural (stereo)

Compatibility: intended for connection to mono or stereo headphones or headsets with nominal impedance of 100 ohms or greater
 Type: voltage driver
 Maximum Output Voltage: 8 Vpp, 150 ohm load

Auxiliary Relay:

Function: software configurable
 Contacts: 2, form C (Common, Normally Closed, Normally Open)
 Rating: 1 A, 30 W (resistive)

Power Source:

24 Vdc nominal, 150 mA max; acceptable range 20-30 Vdc. All units include a universal input/24 Vdc output power supply.

Dimensions (Overall):

5.6 inches wide (14.2 cm)
 3.3 inches high (8.4 cm)
 8.5 inches deep (22.4 cm)

Weight: 3.2 pounds (1.45 kg)

Specifications subject to change without notice.

Additional Model 212 information can be downloaded from www.studio-tech.com. Downloads include:

- User Guide
- Block Diagram
- Configuration Guide
- Model 200-Series Accessories Installation & Configuration Guide

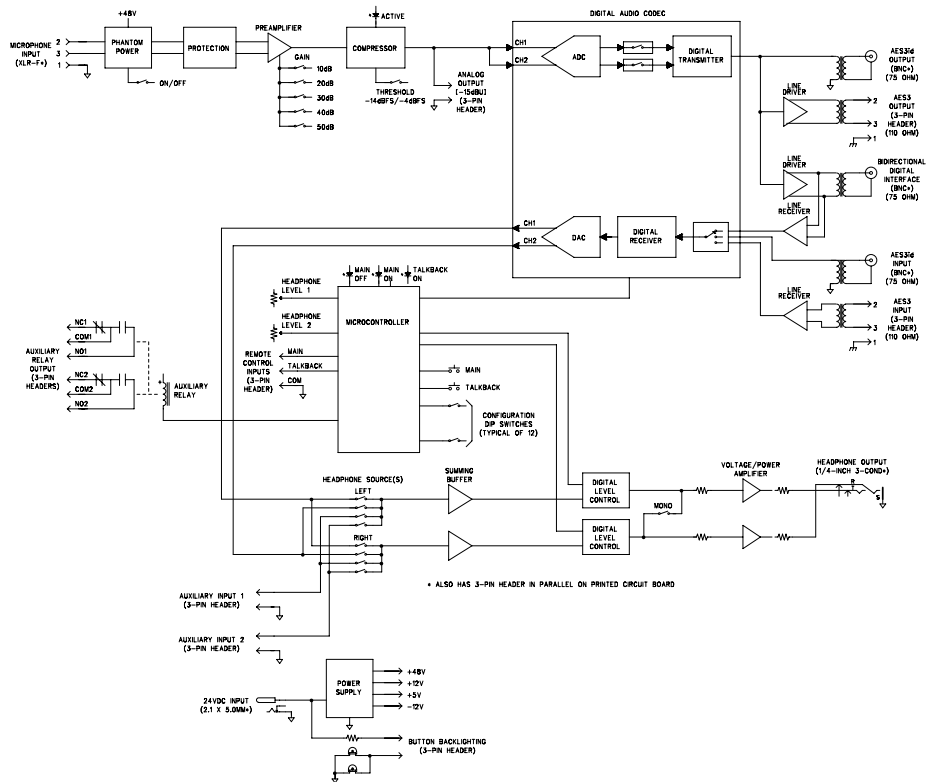

Studio Technologies, Inc.

Skokie, Illinois USA

+1 847-676-9177

© by Studio Technologies, Inc.,

December 2008

www.studio-tech.com