



DWT-B01
DWT-P01
DWR-S01D
DWA-01D

Digital Wireless Microphone System

Sony Digital Wireless Microphone System – a Breakthrough for a New Level of Sound Quality and Operational Convenience

Since their first introduction in 1974, Sony has been continuously developing a rich range of wireless microphone systems to offer superb audio performance, highly stable transmission, and flexible simultaneous multi-channel operation. Nowadays, it can be clearly seen that the industry is migrating from standard definition (SD) to high definition (HD) for video production, as well as from analog to digital for sound production. This trend naturally boosts the need for higher-quality digital technology in wireless microphone systems.

With the introduction of a fully digital wireless microphone system, Sony has made a breakthrough in the history of wireless microphone technology. Comprised of the DWT-B01 bodypack transmitter, DWR-S01D slot-in type two-channel receiver, DWA-01D adaptor, and DTW-P01, newly introduced plug-on transmitter, the system provides excellent-quality digital wireless audio transmission, large-scale, multi-channel operation, and enhanced system flexibility – a perfect match for high-quality ENG/EFM applications.*¹ DWT-P01 is a plug-on transmitter that allows an existing wired microphone to be integrated into the digital wireless microphone system. Its compact and lightweight metal body provides high durability and good balance with compatible microphones, especially when combined with F-112 Sony Dynamic Microphone – ideal for conducting smooth interviews and sound gathering in high-quality ENG applications. Transmission of excellent-quality 24-bit/48-kHz sampling digital audio signals is realized on the DWT-B01 / DTW-P01 transmitter. The audio codec used in the system was developed specifically for wireless audio transmission, enabling the low-latency, secure, and reliable operation that is mandatory for quality-critical applications. In addition, the system allows for an increase of up to 50%*² in the number of simultaneous digital wireless systems in use compared to conventional analog wireless systems, which gives users enhanced system flexibility. Furthermore, the system offers a metadata-handling capability that provides highly innovative full-wireless remote operations between the transmitter and receiver, dramatically improving operational efficiency.

With its excellent audio quality, system flexibility, and operational efficiency, the Sony digital wireless microphone system opens up a whole new world of professional audio applications.

*1 The digital wireless microphone system is not available in some countries.
*2 When operating on a 6-MHz bandwidth TV channel in the USA.



DWT-B01
Digital Wireless Bodypack Transmitter

The ECM-77BC/9X lavalier microphone is an optional accessory.



DWT-P01
Digital Wireless Plug-on Transmitter



DWR-S01D
Digital Wireless Slot-in Type Two-channel Receiver



DWA-01D
Digital Wireless Adapter

System Features

Superb Quality Wireless Transmission

The digital wireless microphone system transmits high-quality 24-bit/48-kHz sampling digital audio signals in a specific frequency bandwidth that meets the wireless-communication regulations of each country. Utilizing an original Sony codec, based on Sony's many years of experience in engineering audio products, the system delivers a wide dynamic range of more than 106 dB, a wide frequency response of 20 Hz to 22 kHz, and an excellent system latency of 3.6 ms.

Simultaneous Multi-channel Operation

The digital wireless microphone system allows for large-scale multi-channel operations. Thanks to the newly developed digital modulator, the system realizes an intermodulation-free, equally spaced channel allocation. The digital wireless transmission technology used in this system enables a significant increase in the number of simultaneous digital wireless systems in comparison with current analog wireless systems. For example, up to 12 channels of simultaneous operation is possible on a 6-MHz bandwidth TV channel in the USA.

This system also provides the option of using existing WL-800 series channel plans. In this configuration, the digital wireless system reliably operates along with WL-800 series analog wireless systems, without concern for having analog and digital wireless systems interfering with each other.

Stable and Secure Transmission

Incorporating a newly developed digital modulator, the digital wireless microphone system allows highly stable and secure wireless transmission that is extremely tolerant to interference waves. The system transmits digitally modulated and encrypted data to minimize the risk of interception, providing highly secure transmission. For secure and confidential communication, the system provides two communication modes: secure key mode and password mode. In secure key mode, wireless communication between a DWT-B01/DWT-P01 transmitter and DWR-S01D receiver can be established by exchanging an encryption key that is generated by the transmitter. In password mode, multiple transmitters and receivers can be configured by setting all devices with the same user-designated password. In addition, this mode supports broadcast communication, which enables multiple receivers to receive audio signals from one transmitter.

Pre-programmed Frequency Groups

To make it easy to choose the correct frequencies for simultaneous multi-channel operation, the optimum intermodulation-free frequencies are stored on each DWR-S01D receiver. These frequencies – all of which have been calculated and tested – are arranged in groups, with each group pre-programmed to allow interference-free operation. The digital wireless microphone system operates within the following frequency ranges:

Frequency range

U models	DWT-B01/DWT-P01 transmitter	U3040	566 to 607 MHz (TV 30 to 36 channels) 615 to 638 MHz (TV 38 to 41 channels)
		U4250	638 to 698 MHz (TV 42 to 51 channels)
	DWR-S01D receiver*	U3032	566 to 590 MHz (TV 30 to 33 channels)
		U4244	638 to 662 MHz (TV 42 to 45 channels)
CE models	DWT-B01/DWT-P01 transmitter	CE6267	798 to 822 MHz (TV 62 to 64 channels) 838 to 862 MHz (TV 67 to 69 channels)
		DWR-S01D receiver	CE62
	CE67		838 to 862 MHz (TV 67 to 69 channels)

* The DWR-S01D receiver supports a 24-MHz band RF carrier frequency range. The DWR-S01D U3032 receiver (Ch block 30/32) can be modified to operate in Ch block 34/36 or Ch block 38/40, and the DWR-S01D U4244 receiver (Ch block 42/44) can be modified to operate in Ch block 46/48 or Ch block 50. To find out more about DWR-S01D frequency modifications, please contact your nearest Sony office or authorized dealer.

System Features

Metadata Transmission

In addition to audio signals, a variety of information about the DWT-B01 /DWT-P01 transmitter – such as audio input level, battery remaining capacity, low-cut filter frequency, and attenuator level – can be wirelessly transmitted to the DWR-S01 receiver as metadata. This allows users to monitor the status of the transmitter from the DWR-S01D receiver, offering high operational convenience.

Innovative Wireless Remote Control

Wireless remote control capability of the Sony digital wireless microphone system is one of the most distinctive features that digital transmission technology has made possible. A variety of DWT-B01 /DWT-P01 transmitter settings – such as power on/sleep, attenuator level, low-cut filter frequency, and RF power output level – can be wirelessly controlled from the DWR-S01D receiver. For DWT-P01, +48 V DC power supply also can be controlled remotely from the receiver or PDW-700 XDCAM® HD422 camcorder. This is highly convenient because setting changes can be made very easily even after the transmitters are attached to an actor or reporter.

Furthermore, when the DWR-S01D receiver is used with the PDW-700, users can monitor the status of the digital wireless microphone system through the camcorder's viewfinder. They can also wirelessly control the settings of the DWT-B01 / DWT-P01 transmitter via the camcorder menu. This wireless control makes use of 2.4-GHz IEEE802.15.4 communication technology, which is commonly available worldwide. Communicating via this wireless technology in no way affects the audio RF signals of either the digital or analog wireless microphone systems. In addition, it is ideal for large-scale multi-channel system management, and is effective for low power consumption.

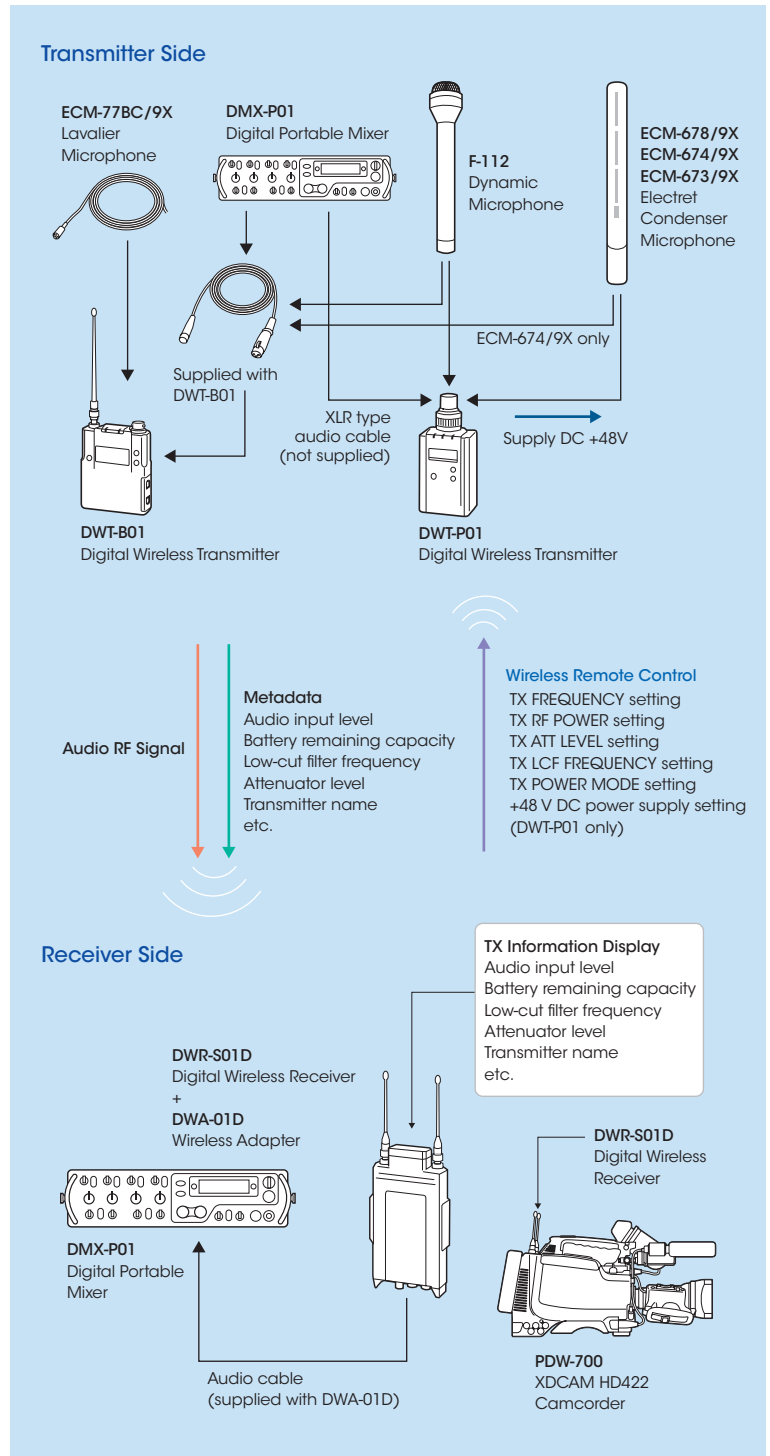



DWT-B01



DWT-P01



DWR-S01D

Easy-to-see, Full Dot-matrix OLED (Organic Light-Emitting Diode) Display

The DWT-B01/DWT-P01 transmitter and DWR-S01D receiver come equipped with an easy-to-see OLED display, providing a variety of information such as operating channel/frequency, AF input level, RF output level, and battery status. The quick response of the OLED display enables real-time operating conditions, such as the audio level meter, to be displayed clearly and accurately. In addition, the OLED provides a high level of visibility even in low-temperature or low-light environments.



DWT-P01

DWT-B01

DWR-S01D

USB Interface

The DWT-B01/DWT-P01 transmitter and DWR-S01D receiver come equipped with a USB interface. This is used to connect a USB keyboard, from which users can easily change a variety of settings. In addition, by connecting the transmitter and receiver directly to each other via the supplied USB cable, the encryption keys required for confidential secure key communication can be exchanged manually or automatically.

DWT-B01 / DWT-P01 Digital Wireless Transmitter

Wide RF Carrier Frequency Range

The DWT-B01/DWT-P01 transmitter covers an extremely wide RF carrier frequency range. The U3040 and U4250 models can cover a 66-MHz*¹ band and 60-MHz*¹ band respectively – much wider than 24-MHz of the analog wireless microphone system, while the CE6267 model can cover a 48-MHz band*². This remarkably wide coverage on a single model offers cost efficiency and operational convenience, because it allows one transmitter to be operated in many different areas.

*¹ The DWR-S01D receiver supports a 24-MHz band RF carrier frequency range.

The DWR-S01D U3032 receiver (Ch block 30/32) can be modified to operate in Ch block 34/36 or Ch block 38/40, and the DWR-S01D U4244 receiver (Ch block 42/44) can be modified to operate in Ch block 46/48 or Ch block 50. To find out more about DWR-S01D frequency modifications, please contact your nearest Sony office or authorized dealer.

*² 798 to 822 MHz (TV 62 to 64 channels) and 838 to 862 MHz (TV 67 to 69 channels).

Compact, Lightweight, and Rugged Design

The DWT-B01 transmitter is designed to be extremely compact and lightweight, essential qualities for use by artists in fast-moving TV and outdoor productions. It measures 2 1/2 x 2 7/8 x 11/16 inches (63 x 73 x 17 mm) and weighs just 4 oz (125 g) including the batteries. In addition, its robust die-cast magnesium body allows the DWT-B01 transmitter to withstand even harsh operational environments. The DWT-P01 transmitter is also designed to be compact and lightweight, to provide good balance with compatible microphones such as F-112. It measures 1 3/4 x 1 3/4 x 3 1/8 inches (44 x 44 x 78 mm) without projection and weighs 9 oz (245 g) including the batteries. And as in the case with the DWT-B01, its robust die-cast magnesium body provides high durability.

Switchable Mic or Line Input Level and Adjustable Attenuator

The audio input level of the DWT-B01/DWT-P01 transmitter is selectable from either MIC or LINE. When MIC is selected, the attenuator can be adjusted in 3-dB steps from 0 dB to 48 dB. The reference input level of the MIC and LINE is -58 dBu (-60 dBV) and +4 dBu, respectively.



DWT-B01 with an optional ECM-77BC/9X lavalier microphone



DWT-P01 with an optional F-112 dynamic microphone

Selectable RF Output Power (1/10/50 mW)

The DWT-B01/DWT-P01 transmitter provides a choice of RF output powers. The 1 and 10 mW output is suitable for multi-channel operations such as theater and studio productions, while the 50 mW output is intended for long-distance transmissions such as sports and news coverage.

Power Sleep Mode

The DWT-B01/DWT-P01 transmitter is equipped with a power sleep/wake up mode that can be wirelessly controlled from the DWR-S01D receiver. Wherever the transmitter is attached - for example, inside an actor's costume - the operator can remotely control the transmitter's power on and sleep settings, increasing operational convenience and battery savings.

Digital Low-cut Filter

Equipped with a digital low-cut filter, the DWT-B01/DWT-P01 transmitter can reduce the effects of undesired ambient noise.

Dimensions

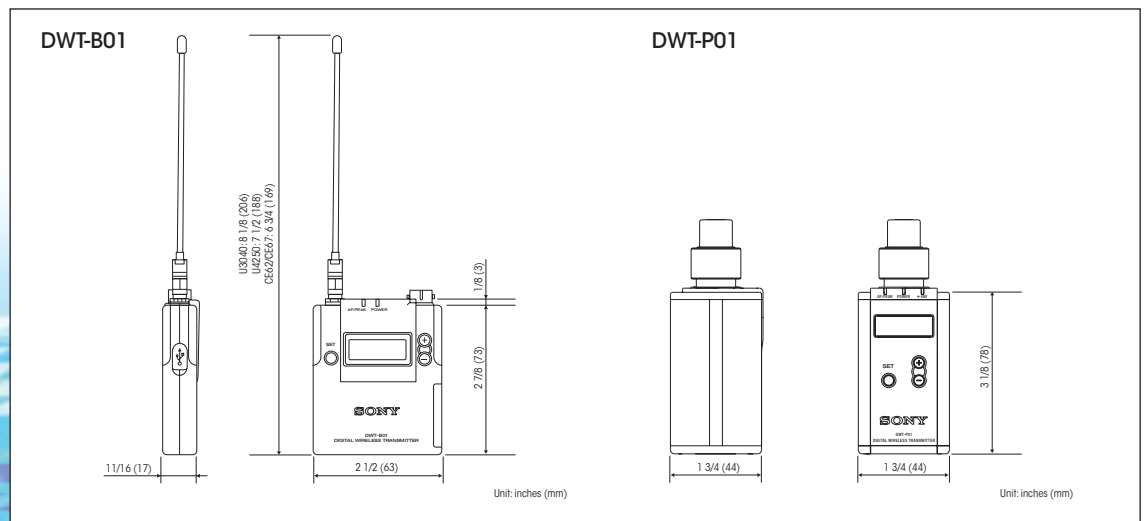

DWR-S01D Digital Wireless Receiver

Industry-first Two-channel Slot-in Wireless Receiver

The DWR-S01D is an industry-first two-channel digital wireless receiver that offers an ideal solution for high-quality ENG and EFP applications. Despite its dual-channel receiver capability, the DWR-S01D receiver is small enough to be mounted directly in the slot of the Sony PDW-700 XDCAM HD422 camcorder, maintaining the well-balanced design and compactness of the camcorder. Through the direct mount, high-quality digital audio transmitted from a DWT-B01/DWT-P01 transmitter can be recorded directly to the camcorder via a D-sub 15-pin interface without the need for any signal conversions.



PDW-700
XDCAM HD422 Camcorder

Rear Mounting to Camcorders

In addition to the slot-in capability for the PDW-700 XDCAM HD422 camcorder, the DWR-S01D receiver can be rear-mounted to a range of Sony professional camcorders – such as the HDCAM®, XDCAM, XDCAM HD, Digital Betacam®, and MPEG IMX® series camcorders – using the DWA-01D adapter. When used with a camcorder that has AES/EBU inputs, full-digital audio recording is also possible.



Sony Professional Camcorder
with DWR-S01D

Compact, Lightweight, and Rugged Design

Despite having a number of stunning functionalities, such as its dual-channel receiver capability, the DWR-S01D is still highly compact and lightweight – just like the existing analog, one-channel wireless receiver WRR-855S. It measures only 3 1/2 x 4 3/4 x 1 1/4 inches (88 x 119 x 31.3 mm) and weighs just 9 oz (280 g), maintaining a good balance even when mounted on a camcorder. In addition, the DWR-S01D is made of magnesium die-cast and aluminum, making it extremely rugged and suitable for the harsh environments of even the most demanding ENG applications.

Auto Channel Scanning Functions

The DWR-S01D receiver comes with two auto channel scanning functions that allow for fast, easy, and safe frequency channel changes. Clear Scan mode automatically seeks unoccupied channels, from which operators can select the most appropriate channel to use. While Active Channel mode searches for channels that are currently in use, allowing operators to check whether the channel is used by a transmitter in the same operational group.

Wireless Remote Control

The wireless remote control is an extremely efficient feature that enables the DWR-S01D receiver to control various settings of the DWT-B01/DWT-P01 transmitter such as power on/sleep, attenuator level, low-cut filter frequency, and RF power output level. For DWT-P01, +48 V DC power supply also can be controlled remotely from the receiver or PDW-700 XDCAM HD422 camcorder.



Dimensions

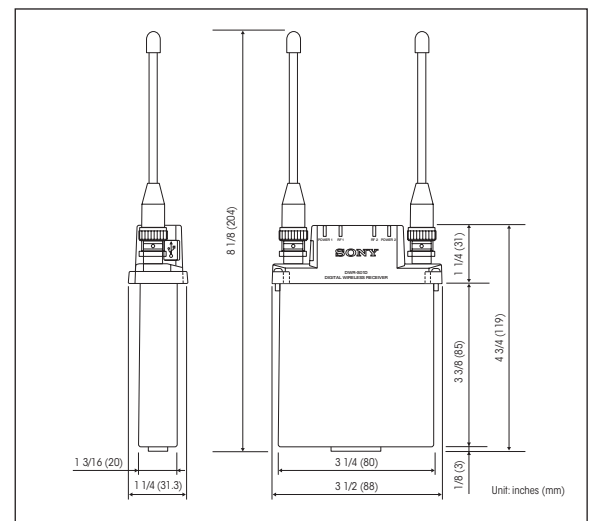

DWA-01D Digital Wireless Adapter

Camcorder Rear-mount Operation*¹

The DWA-01D adapter allows the DWR-S01D receiver to be rear-mounted on a range of Sony professional camcorders, such as HDCAM, XDCAM, XDCAM HD, Digital Betacam, and MPEG IMX camcorders. In addition, the DWA-01D adapter can be used with the current analog wireless receiver WRR-855S.*²

*¹ Requires an optional mount bracket (A-8278-057B).

*² Output from the DWA-01D and WRR-855S is one-channel analog audio signal only.



DWA-01D Supplied Accessories



Stand-alone Wireless Receiver Operation

In addition to the camcorder mount operation, the DWR-S01D receiver with DWA-01D adapter can also work as a stand-alone wireless receiver.* This, in combination with a digital audio mixer such as the Sony DMX-P01, allows users to establish a compact, handy, and digital wireless microphone system.

* Requires DC power supply from a connected unit via a 4-pin connector.

Unique Joint Mechanism

The DWA-01D adapter is equipped with a joint bracket that allows two DWA-01D adapters to be easily combined. This is particularly convenient for when two pairs of the DWR-S01D receiver and DWA-01D adapter are used at the same time as a stand-alone four-channel receiver system.

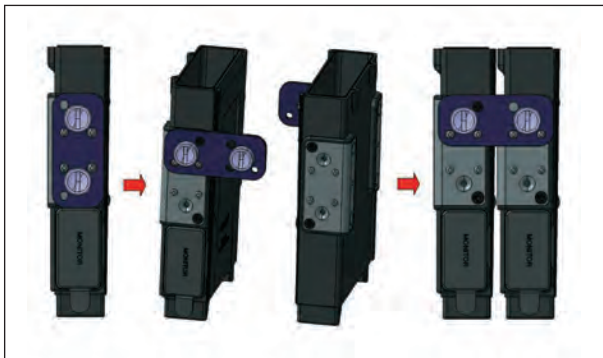



Wide Array of Interfaces

The DWA-01D adapter comes equipped with a wide range of interfaces optimized for diverse operational needs:

- SMC9-4S (Sony 4-pin) (x 2): Outputs either AES/EBU or analog audio signals.
- Word Sync input: Allows the digital wireless microphone system to synchronize with an external word sync signal.
- Stereo headphone output: Offers easy monitoring of the output sound (switchable among Tuner 1/Tuner 2/Mixed).

Dimensions

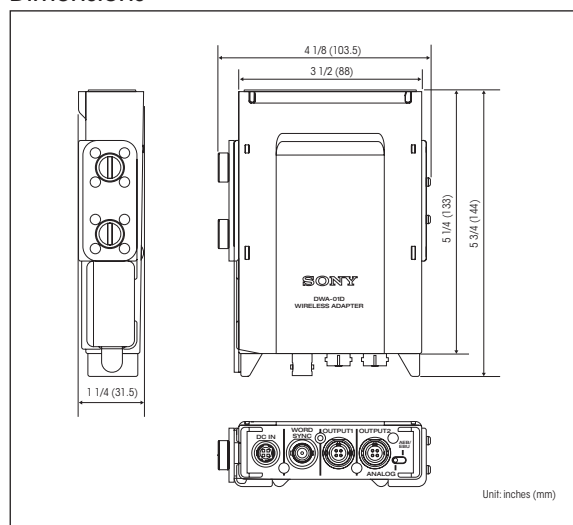

Optional Accessories



ECM-77BC/9X
Lavalier Microphone



F-112
Dynamic Microphone



DMX-P01
Digital Portable Mixer

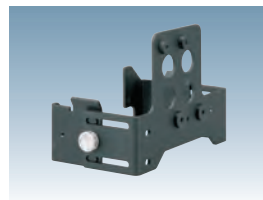

A-8278-057-B
Mounting Bracket

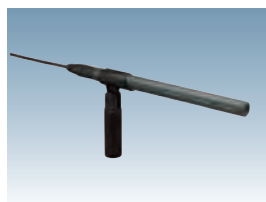

ECM-678/9X
Shotgun Microphone



ECM-674/9X
Shotgun Microphone



ECM-673/9X
Shotgun Microphone

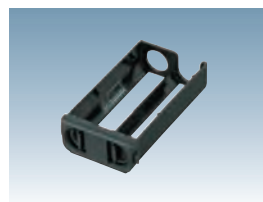

BATC-A22
Battery Case

Specifications

System specifications		
Sampling frequency		48 kHz
Quantization bit length		24 bit
Reference input level (at 0-dB audio attenuator level)	MIC LINE	-58 dBu, 1 kHz (-60 dBV, 1 kHz) +4 dBu, 1 kHz
Reference output level	Analog output AES/EBU output	-58 dBu -36 dBFS/-20 dBFS switchable
Maximum output level	Analog output AES/EBU output	-22 dBu 0 dBFS
Frequency response		20 Hz to 22 kHz
Dynamic range		106 dB typical (A-weighted, T.H.D.=1%)
Distortion (T.H.D.)		0.03% or less
Modulation method		$\pi/4$ Shift QPSK
Audio delay		3.6 ms
Remote control		2.4 GHz IEEE802.15.4 compliant
USB		USB 2.0 compliant

	DWT-B01	DWT-P01
Transmitting section		
Oscillator	Cristal controlled PLL synthesizer	
Carrier frequency range	U3040	566 to 607 MHz (TV 30 to 36 channel) 615 to 638 MHz (TV 38 to 41 channel)
	U4250	638 to 698 MHz (TV 42 to 51 channel)
	CE6267	798 to 822 MHz (TV 62 to 64 channel) 838 to 862 MHz (TV 67 to 69 channel)
Channel step	U3040/U4250 CE6267	125 kHz 25 kHz
RF power output	1 mW/ 10 mW / 50 mW (e.r.p.) selectable	
Occupied RF bandwidth	192 kHz	
Audio delay	1.5 ms	
Audio section		
Maximum input level	MIC LINE	-22 dBu (with 0 dB attenuator) +24 dBu
Audio attenuator adjustment range (pad)	0 to 48 dB (3-dB steps, MIC input mode only)	
Input connector	Sony 4-pin (SMC9-4S) (x1)	XLR-3-11C (female) (x1)
Input impedance	4k Ω or more	
General		
Operating voltage	DC 3.0V (two LR6 AA-size alkaline batteries)	
Battery life	Approx. 3.5 hours at 10mW output (at 77°F (25°C), with Sony LR6 AA-size alkaline batteries)	
Dimensions (W x H x D)	Approx. 2 1/2 x 2 7/8 x 1 1/16 inches (63 x 73 x 17 mm) excluding projection	Approx. 1 3/4 x 3 1/8 x 1 3/4 inches (44 x 78 x 44 mm) excluding projection
Weight	Approx. 4 oz (125 g) including batteries	Approx. 9 oz (245 g) including batteries
Supplied accessories	Soft case (x1), Spare battery case (x1), Microphone cable (4-pin to XLR-3-pin) (x1), USB adapter cable (x1), USB cable (x1), Carrying case (x1), Scribble sheet (x1), Operating instructions (x1)	Spare battery case (x1), Soft case (x1), USB adapter cable (x1), USB cable (x1), Operating instructions (x1)

DWR-S01D		
Tuner section		
Type of reception	Space diversity	
Circuit system	Dual conversion superheterodyne	
Receiving frequency range*	U3032 U4244 CE62 CE67	566 to 590 MHz (TV 30 to 33 channels) 638 to 662 MHz (TV 42 to 45 channels) 798 to 822 MHz (TV 62 to 64 channels) 838 to 862 MHz (TV 67 to 69 channels)
Channel step	U3032/U4244 CE62/CE67	125 kHz 25 kHz
Local oscillators	PLL synthesizer	
RF input terminal	BNC-R, 50 Ω	
Sensitivity	20 dB μ or less (at bit error rate=1 x 10 ⁻³)	
Audio delay	2.1 ms: analog output 1.9 ms: digital output	
Audio section		
Audio output connector	D-sub 15-pin (x1)	
General		
Dimensions (W x H x D)	Approx. 3 1/2 x 4 3/4 x 1 1/4 inches (88 x 119 x 31.3 mm) excluding projection	
Weight	Approx. 9 oz (280 g)	
Supplied accessories	Whip antenna (x2), USB cable adapter (x1), USB cable (x1), Frequency band label (x1), Operating instructions (x1)	

DWA-01D		
Audio section		
Output connector	Sony 4-pin (SMC9-4S) (x2) (OUTPUT1, OUTPUT2)	
Analog audio output impedance	150 Ω or less	
AES/EBU audio output impedance	110 Ω	
WORD SYNC input	BNC-R, 75 Ω , lockable range: 32 to 96 kHz	
Monitor output connector	ϕ 3.5 mm stereo mini-jack	
Monitor output level	50 mW (at 16 Ω load, T.H.D.=1%)	
General		
Power requirements	DC 12 V	
Operating voltage	DC 10 to 17 V	
Dimensions (W x H x D)	Approx. 3 1/2 x 5 3/4 x 1 1/4 inches (88 x 144 x 31.5 mm) excluding projection	
Weight	Approx. 11 oz (330 g)	
Supplied accessories	Audio cable (x2), DC cable (x1), Mount plate (x1), Operating instructions (x1)	

* The DWR-S01D receiver supports a 24-MHz band RF carrier frequency range. The DWR-S01D U3032 receiver (Ch block 30/32) can be modified to operate in Ch block 34/36 or Ch block 38/40, and the DWR-S01D U4244 receiver (Ch block 42/44) can be modified to operate in Ch block 46/48 or Ch block 50. To find out more about DWR-S01D frequency modifications, please contact your nearest Sony office or authorized dealer.

SONY

Sony Electronics Inc.
1 Sony Drive
Park Ridge, NJ 07656
[click: sony.com/proaudio](http://click.sony.com/proaudio)

A-1174 (MK10554V1)

©2009 Sony Electronics Inc. All rights reserved.
Reproduction in whole or in part without written permission is prohibited.
Features and specifications are subject to change without notice.
All non-metric weights and measurements are approximate.
Sony, HDCAM, XDCAM, Digital Betacam, and MPEG IMX are trademarks of Sony.

Printed in USA (2/09)