

TANNOY®



TANNOY  
7450028 No task+  
00TLevel -50.0 dB  
IDP INTERACTIVE DIGITAL PROGRAMMING

TANNOY  
7450028 task+  
StandBy -50.0 dB  
IDP INTERACTIVE DIGITAL PROGRAMMING

EXIT  
ENTER

**PRECISION** IDP TECHNOLOGY  
ACTIVE STUDIO MONITORS

## Precision iDP™

**Tannoy iDP™ (Interactive Digital Programming) technology provides a powerful digital solution to precision defined acoustics and ultimate monitoring flexibility. Precision iDP™ studio monitors incorporate a host of technology, including DSP, networking intelligence and class D digital amplifiers, along with a fully re-engineered Dual Concentric™ driver and WideBand™ technology. All these factors combine with iDP™ to provide the professional user with an exceptional level of performance, operation convenience and complete control over the entire monitoring operation.**

## a history of precision

Tannoy's reputation in the professional recording industry borders on legendary. For over six decades as recording history has been made Tannoy studio monitors have been at the forefront. From such emblematic productions as Decca's FFSS recording of Wagner's Das Rheingold with the Vienna Philharmonic under Georg Solti in 1957; arguably still one of the finest classical recordings of all time, to the re-birth of Rock and Roll we know as the British Invasion, Tannoy monitors have helped recording engineers and producers create historic music. Times may have changed, but our engineering values and commitment to perfection have not. Everything we do today is judged against our considerable achievements of the past as we continue to advance the art and science of building the world's premier reference monitors. Constant refinement of our famed Dual Concentric™ driver, pioneering work with WideBand™ technology, advanced Klippel™ analysis and a host of other technologies ensure that with every new product comes another historic chapter.

# accuracy

## accuracy through precision

Tannoy Precision near field reference monitors have been created to serve the demanding needs of professionals in recording, broadcast and post production environments. Engineered to the highest sonic standards and build quality, Precision will impress you whether you're a seasoned Tannoy user or just taking your first step up into a monitor system based on the legendary Dual Concentric™ driver.

With nearly six decades of refinement behind it, the Dual Concentric™ driver represents a near perfect point source, preserving the tonal character and harmonic structure of program material as no discrete driver system can. The benefits are immediately obvious with flat response, controlled dispersion and a wider sweet spot in both the horizontal and vertical planes.

Precision models include Tannoy's WideBand™ technology, extending high frequency response to above 50 kHz. This extended range not only affords all of the bandwidth required for today's wide bandwidth digital recording formats, but also ensures that phase error is minimised through the entire audible spectrum. While many designers employ the "cut and paste" development method, Tannoy engineers routinely design their own transducers using the most advanced software and techniques available. Precision's drivers are all new designs developed using Klippel™ symmetry and non-linear distortion analysis, laser-scanning interferometry and advanced acoustic CAD simulation.



# through precision



**Tannoy Dual Concentric™**

First developed in 1947 and refined relentlessly ever since, the Dual Concentric™ driver is actually two drivers properly merged into one. The high frequency driver is positioned on the back of the low frequency magnet and fires through the centre of the cone. The result is that the acoustic apex of the high and low frequency drivers is aligned in three axes; a true point source.



DUAL CONCENTRIC™ POINT SOURCE, CONSTANT DIRECTIVITY DRIVER

In a Dual Concentric™ driver all signals emanate from the same place in space and therefore in time, arriving at the listener precisely as they were when they were recorded. Discrete drivers are displaced in space and therefore their signals arrive at the listener at different times, causing uneven response and imaging smear. As a Dual Concentric™ is aligned on all three axes the listening field is wider in both the horizontal and vertical planes. Discrete systems suffer from a narrow sweet spot, even when they use signal delay as an attempt to align the transducers.

Discrete driver speaker systems cannot reproduce signals accurately because their sources are displaced in space.

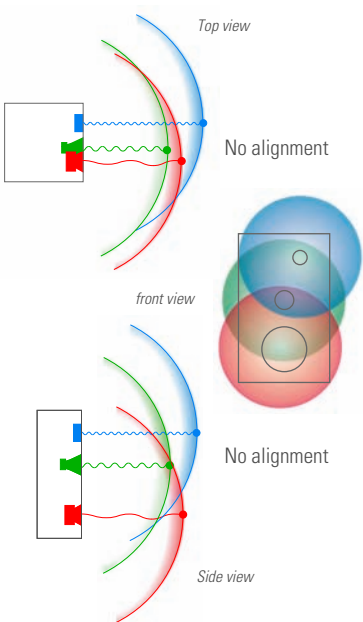

Even when delays are applied to compensate for driver alignment, signals can only be aligned along a narrow listening plane on one axis.

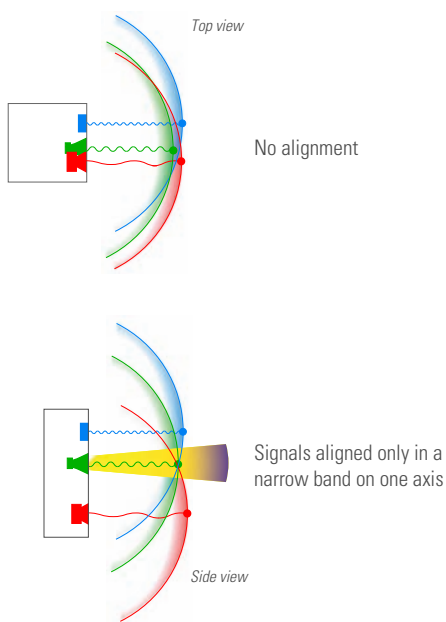

In a Dual Concentric™ driver the signal sources are perfectly aligned, resulting in smooth response and a wide listening area in both horizontal and vertical axes.

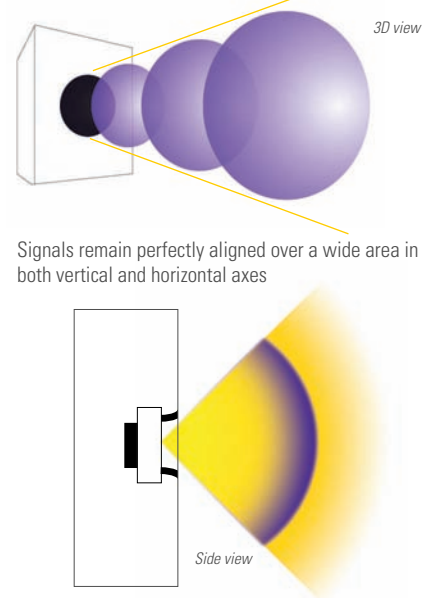

■ High Frequency

■ Mid Frequency

■ Low Frequency

■ Signal sources aligned

A Dual Concentric™ drive unit exhibits constant directivity. The controlled even dispersion gives greater intelligibility even in difficult acoustic spaces, where the sound from the speaker can be more accurately targeted to where it is needed.

HARMONIC RELATIONSHIPS USING MULTIPLE SOURCES

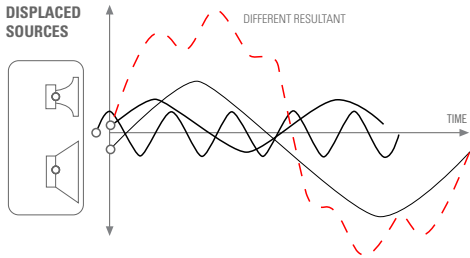

HARMONIC RELATIONSHIPS PRESERVED USING A SINGLE POINT SOURCE

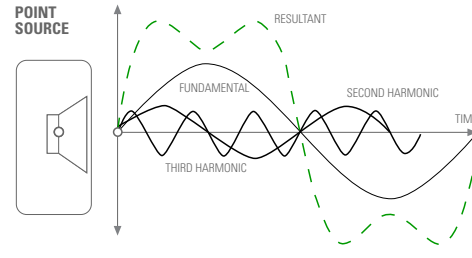

ORIGINAL VERSUS DISTORTED RESULTANT

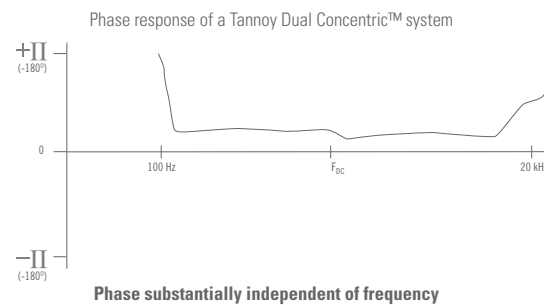
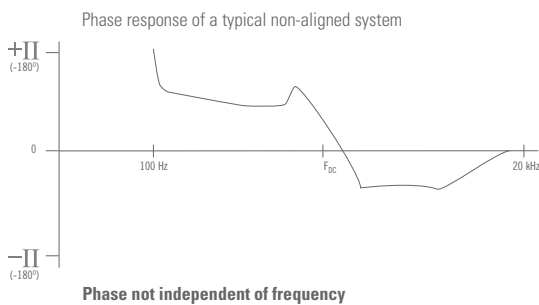
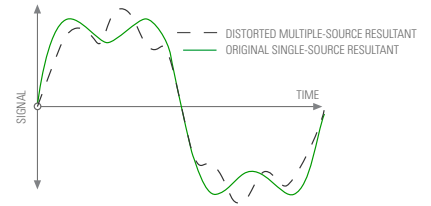

The latest version of the Dual Concentric™ features a new WaveGuide™ fitted directly in front of the HF diaphragm. Energy is emitted from an HF unit as a plane wave; the purpose of the flared shape of the WaveGuide™ device being to delay and therefore reshape this into a spherical wave front. This effect provides this unique drive unit design with its superb constant directivity performance.

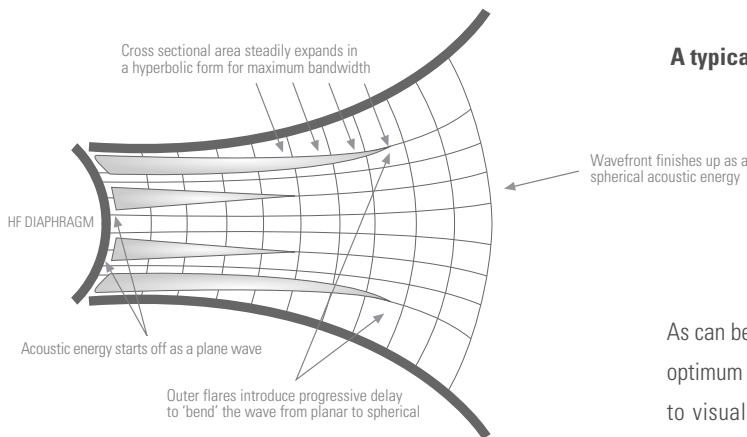

**A typical Tannoy HF Tulip WaveGuide™**



As can be seen from the diagram, the flares in the WaveGuide™ are creating the optimum acoustic condition - a spherical wave pattern; the best analogy for which is to visualise the wave form as an expanding sphere as it leaves the drive unit.

The shape of the main bass cone continues the flare ratio created by the WaveGuide™; essential to sustain the integrity of this spherical wave front as it is projected from the speaker. The crucial benefit to the listener whether in near field conditions or otherwise, is that the monitor delivers consistent performance in both the horizontal and vertical planes; something simply not achievable with displaced driver (discrete) systems.

In its monitor designs Tannoy has always minimised the number of crossover points that fall inside the critical response band; frequencies between 125Hz and 8kHz being the most susceptible to human perception of phase shift. To reduce potential phase errors and create a more natural and accurate sounding product, Tannoy engineers design systems with no more than one crossover point through this crucial band. The total number of crossover points is therefore reduced; with those that are essential being added above and / or below this critical frequency range. An approach less likely to introduce any negative acoustical effects in what the listener hears.

**Extended frequency response**

Tannoy has always been an innovator where quality sound reproduction is concerned. Over recent years Tannoy has been at the forefront of developing loudspeakers with WideBand™ performance. In the case of the Precision monitors, this entails the addition of a baffle mounted, acoustically time-aligned, proprietary SuperTweeter™; extending frequency response to 51kHz.

Extending the high frequency roll-off out to 51kHz corrects the time or phase response at the upper end of audibility, resulting in enhanced accuracy and ‘spaciousness’, improved clarity within the essential mid band area, and even enhancing definition of low frequencies. This benefit is heard clearly with any source material, regardless of bandwidth. Tannoy WideBand™ Technology is an essential component of the Precision monitor design in that it delivers increased tonal accuracy of the individual instruments in the recording process - a mix critical factor in that it allows for the best EQ and placement decisions to be made.

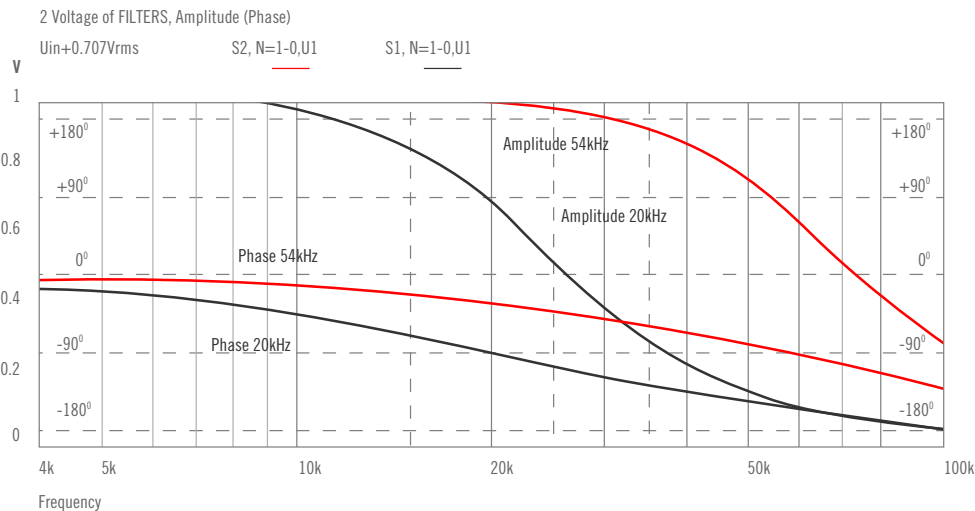

This plot shows the actual measured phase error for two different loudspeaker systems. One system has an upper end roll off at 20kHz while the other extends on out to a 54kHz roll off. There is clearly less phase error in the latter case, not just at high frequencies, but also well within the accepted range of human hearing where harmonic recognition starts as low as 5kHz.

**Obsessive about Precision**

Clearly, to build the best studio monitors you must start with the very best drivers. At Tannoy our reputation for excellence is built on the quality and performance of the speaker systems we build, and that is why we continue to design and manufacture our own drivers. Taking a chance on third-party drivers would simply defeat the purpose of the Precision range.

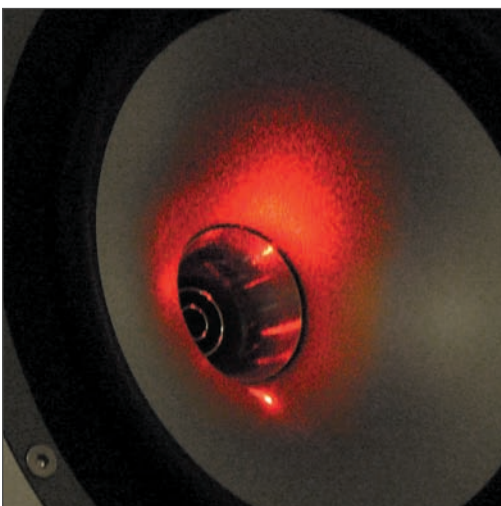

Tannoy engineers have access to the superb Klippel™ measurement system and employed this expertise in the driver development for Precision iDP™. This integrated suite of hardware and software tools allowed our engineers to take the proposed drive unit design and measure the large-scale parameters to detect and improve the mechanisms causing non-linearities.

The benefit being the ability to accurately measure the driver's behaviour and to optimise the performance for their application in these high performance monitors. The net acoustic benefit being significantly lower distortion and amazing consistency at all power levels.

*Klippel™ laser measurement system enables large signal linearity of a driver to be optimised.*

## Precision iDP™ Technology

Precise room optimisation has now taken a quantum leap forward thanks to the development of Tannoy iDP™ (Interactive Digital Programming) Technology. Precision iDP™ is a brand new and stunningly versatile intelligent active monitoring system, combining the unique Tannoy Dual Concentric™, WideBand™ technology with the latest cutting edge digital processing.

DSP technology, networking intelligence and Class D amplifiers are features that replace the need for expensive external analogue routing matrices. Set-up time for multi-purpose rooms is minimised while complicated cabling considerations are solved by the use of tc-link network topology; with software updates uploaded via the same network connections.

These monitors provide the professional user with complete control over the entire monitoring operation with the following advantages over conventional monitors:

### Feature and Benefits

- Ⓢ 32kHz to 96kHz sample rate support
- Ⓢ Preset storage / recall and total acoustic alignment flexibility
- Ⓢ 'Real time' control of bass management, preset recall, solo / mute functions etc
- Ⓢ Bass management with selectable frequency crossover points
- Ⓢ Individual loudspeaker optimization
- Ⓢ Global level control
- Ⓢ Programmable reference levels
- Ⓢ Acoustic tuning via a comprehensive array of EQ parameters and alignment facilities
- Ⓢ AES/EBU input for direct digital interfacing
- Ⓢ Full Networking capability for both audio and control within the digital domain
- Ⓢ Complete manipulation of any speaker parameter on the network using PC-iP™ or iDP SOFT™
- Ⓢ 2.1, 5.1, 6.1 and 5.3 set-ups supported

### Applications

- Ⓢ Post Production
- Ⓢ Music Recording and Mixing
- Ⓢ Film Editing
- Ⓢ DVD Authoring and Mastering
- Ⓢ 5.1 Production
- Ⓢ Broadcast
- Ⓢ Edit suites

## Precision iDP™ Connectivity

Tannoy Precision iDP™ systems are based on a Master / Slave topology. Each Master acts as the analogue audio input point as well as the processing controller. A dot matrix display and four control buttons on the front of each speaker allows direct access to the speaker's settings. They also come equipped with an AES/EBU input on XLR for direct interface to a digital source. Precision iDP™ offers full networking capability, both audio and control, within the digital domain, and by default the digital inputs accommodate any of the standard sample rates from 32 to 96kHz. As the system operates as a network it is possible to see and manipulate any speaker on the network when connected to any 'node' on the network when using PC-iP™ or iDP SOFT™. Optionally the two analogue input connectors can be replaced in the master modules with a dual AES/EBU input module allowing AES/EBU digital surround setups accepting sources up to 192kHz ensuring compatibility with current and future production requirements.



Slave

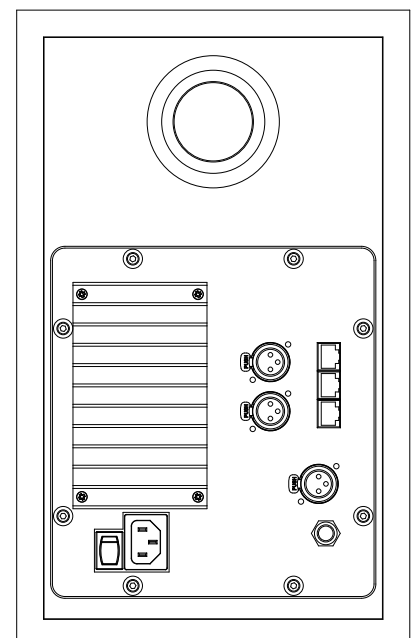

Master

**Precision iDP™ Software**

Using the supplied PC-iP™ installer software each speaker is assigned a task so that the network recognises where each monitor is placed in the system. In order to initially optimise the monitors for a specific room, any good quality real time analyser (RTA) can be used to measure each of the speakers.

Acoustic tuning via a comprehensive array of EQ parameters and alignment facilities can then be applied in order to recalibrate each monitor to achieve a flat response within the listening room.

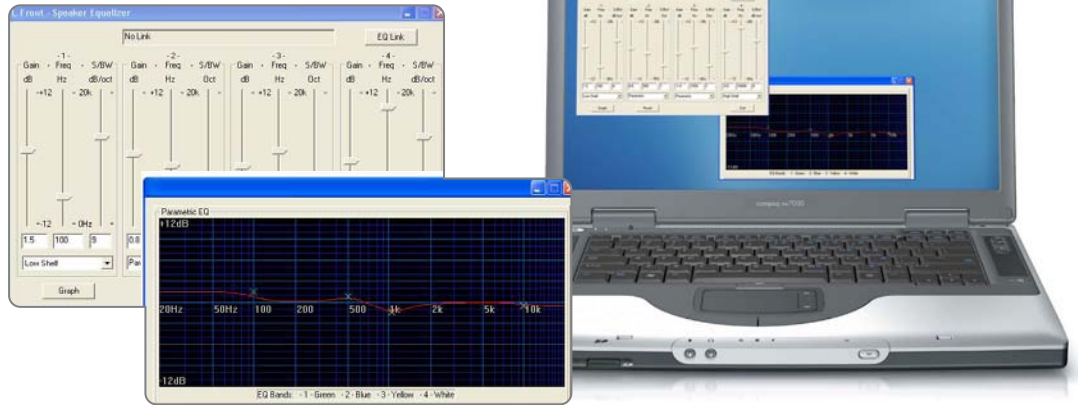

Selectable crossover frequencies can be established for a wide variety of different recording circumstances, and these can be stored as presets for instant recall from the remote control. All profiles within Precision iDP™ can be changed as required, then stored as presets for instant recall whenever needed. For example, presets can easily be established for the individual performance parameters of the differing standards such as DTS, THX etc.



Bass management with selectable frequency crossover points

Loudspeaker optimisation and network set-up

Studios are typically not just working on one project. There may be variable numbers of loudspeakers (2 / 2.1 / 5.1 / etc) being used for different projects and some jobs may span weeks at a time. The facility to save and recall different settings via presets for different projects minimises studio set up time – a real cost benefit!

Bass management (sometimes called bass redirection) is a very important and useful tool. With conventional studio monitors external electronics is required to achieve bass management. It is in general an absolute necessity if you want to make a multi-channel set-up in a small room. The bass management system is designed to subtract the bass contents of all main channels and reproduce this by the use of a subwoofer. iDP™ systems provide a number of possible crossover frequencies that can be determined by the user.



The full system can be configured and controlled in the following ways:

## Baffle mounted control module

Using the display/control module on the Master monitor's front baffle allows for manual adjustment of system presets and loudspeaker configuration.



## Tannoy iDP SOFT™

This software package is a beautifully simple PC or MAC based system controller/ software editor. The intuitive on-screen user interface is designed to easily manipulate all parameters in the Precision iDP™ monitors; making this a flexible day-to-day system configuration tool.



## Remote control

Part of the Precision iDP™ accessory options package, this is a dedicated remote control unit that can be plugged into an RJ45 socket on one of the system's speakers via a TC-link cable. The remote provides global level and access to four pre-stored system presets and three pre-stored reference levels. Mute / solo buttons are provided for each channel of a 5.1 system, allowing any single or multiple combination of loudspeakers to be auditioned or muted.



A small but powerful system control tool, ideal where studio space is limited, this remote control unit replaces the need for analogue control room electronics for multi-format mixing that is both expensive to install and often colours the signal path.

**Choosing the right size**

Available in two sizes, Precision iDP™ monitors are configured with either an 6" or 8" Dual Concentric™ driver, which allows for different room size and power handling considerations.

The smaller Precision 6 iDP™ is intended for rooms of around 40 – 90 cubic metres with a listening distance of 1.0 – 2.0 metres. The bass and mid / HF are driven actively and the SuperTweeter™ is coupled passively in this semi active design. The frequency response is 56Hz – 51kHz +/- 2dB with a maximum SPL of 117dB at the mix position (configured for near field operation).

The larger Precision 8 iDP™ utilises the same amplifier configuration as the smaller model and is intended for use in rooms of around 50 – 100 cubic metres with a listening distance of ideally 1.3 – 2.8 metres. The frequency response is 43Hz – 51kHz +/- 2dB with a maximum SPL of 120dB at the mix position (configured for near field operation).

The LF and HF sections of the Dual Concentric™ are separately driven by their own 200-Watt Class D PWM (pulse width modulation) amplifier. The internal mains power supply is a switched mode type, accepting 100 – 240 Volt mains (50 – 60Hz)



Precision 6 iDP™

Precision 8 iDP™

**Tannoy iDP™ subwoofers**

Two exceptionally powerful active subwoofers have been designed to complement the monitors. Both are substantially constructed, acoustically inert, infinite baffle cabinets in which exceptionally high power handling and long throw drive units really do deliver tightly controlled bass with massive impact.

Full iDP™ technology functionality is incorporated to allow completely network flexibility so that a system can be configured as 2.1, 5.1, 7.2 or in any other multi channel combination required. Bass management and crossover facilities specifically for the subwoofer allow change of the filter slope between 2nd, 4th and 6th order.

In most circumstances the 22 litre single 12" driver equipped TS112 iDP™ is the ideal partner for the Precision monitors, particularly the 6" driver model. However, for exceptionally demanding situations where huge bass performance is required, the 45 litre TS212 iDP™ subwoofer utilises two of these 12" side-firing metal-coned drive units.



TS112 iDP™



TS212 iDP™

With 1.5 kilowatts of power in the TS212 iDP™ and 750W in the TS112 iDP™ there is massive power overhead available to ensure that the punch and drive of the mix track is faithfully reproduced.

**Technical Specifications - Precision 6 iDP™****System (Master & Slaves)**

System	3-Way semi-active near field monitor
Frequency Response <sup>(1)</sup>	56Hz – 51kHz (+/- 2dB)
Max. SPL (@ 1m) <sup>(2)</sup>	117dB (continuous)
Dispersion (-6dB)	90 degrees
Crossover Frequency	1.9kHz (DSP generated) & 16kHz (passive)
Drive Units	165mm (6") Tannoy Dual Concentric™ constant directivity driver with multiple fibre paper pulp cone 25mm (1") titanium dome WideBand™ SuperTweeter™ Neodymium magnet system
Cabinet LF Alignment	Optimised bass reflex loaded
Dimensions (H x W x D)	356mm x 220mm x 369mm (14" x 8 <sup>5</sup> / <sub>8</sub> " x 14 <sup>1</sup> / <sub>2</sub> " )
Cabinet Construction	MDF cabinet and front baffle, tongue and groove front and back Black cabinet grey painted baffle with brushed aluminium inlay Black anodised aluminum back plate
Total weight	12 kg (26.4lbs)

**Electronic System**

Mains	Voltage 100 to 240Vac, 50 – 60Hz (auto – select)
Power Consumption	45W @ 1/8 full power (IEC 6065)
Amplifier	Bass/midrange – 200 Watts Class D Tweeter & SuperTweeter™ - 200 Watts Class D

**System Sample Rates:**

Internal	96 kHz (except when slaved to digital input or word clock input)
External	96, 88.2, 64, 48, 44.1 or 32 kHz (optional 192kHz)

**Digital Section (Master only):**

I/O connectors	XLR (2 channels AES/EBU in). 3 x RJ45 proprietary TC LINK
Formats	AES/EBU
Word Clock	Input BNC, 75 Ω, 0.6 to 10 Vpp
Display	2 x 16 character dot matrix
Operation	Menu system / four buttons

**Analogue Section (Master only):**

Input connectors	XLR balanced (pin 2+, pin 3-)
Impedance	10/3 kΩ (balanced/unbalanced)
Selectable Full Scale Input level	+9, +15, +21, +27 dBu
Dynamic Range	> 113 dB typ. (unweighted), BW: 20-20kHz
THD+N	< -105 dB typ. @ 1 kHz, -3 dBFS
Crosstalk	< -120 dB, 20 Hz to 20 kHz

**A to D Conversion**

24 bit (Dual bit delta sigma sampling at 4.1/5.6/6.1/6.1MHz)

**Slaves Only:**

I/O connector's	2 x RJ45 proprietary TC LINK
-----------------	------------------------------

The typical listening distance for **Precision 6 iDP™** is 1-2m. The typical room size for **Precision 6 iDP™** is 40-90 m<sup>3</sup>

**NOTES**

<sup>(1)</sup> +/- 3 dB, measured at 1m in an anechoic chamber. <sup>(2)</sup> Peak SPL at mix position for 1 pair driven.

Tannoy operates a policy of continuous research and development. The introduction of new materials or manufacturing methods will always equal or exceed the published specifications which Tannoy reserve the right to alter without prior notice. Please verify the latest specifications when dealing with critical applications.

## Technical Specifications- Precision 8 iDP™

### System (Master & Slaves)

System	3-Way semi-active near field monitor
Frequency Response <sup>(1)</sup>	43Hz – 51kHz (+/- 2dB)
Max. SPL (@ 1m) <sup>(2)</sup>	120dB (continuous)
Dispersion (-6dB)	90 degrees
Crossover Frequency	1.7kHz (DSP generated) & 16kHz (passive)
Drive units	200mm (8") Tannoy Dual Concentric™ constant directivity driver with multiple fibre paper pulp cone. 25mm (1") titanium dome WideBand™ SuperTweeter™, Neodymium magnet system
Cabinet LF Alignment	optimised bass reflex loaded
Dimensions (H x W x D)	440mm x 272mm x 369mm (17 3/8" x 10 3/4" x 14 1/2")
Cabinet Construction	MDF cabinet and front baffle, tongue and groove front and back. Black cabinet grey painted baffle with brushed aluminium inlay. Black anodised aluminum back plate.
Total weight	17 kg (37.4lbs)

### Electronic System

Mains Voltage	100 to 240Vac, 50 – 60Hz (auto – select)
Power Consumption	45W @ 1/8 full power (IEC 6065)
Amplifier	Bass/midrange – 200 Watts Class D Tweeter & SuperTweeter™ 200 Watts Class D

### System Sample Rates:

Internal	96 kHz (except when slaved to digital input or word clock input)
External	96, 88.2, 64, 48, 44.1 or 32 kHz (optional 192kHz)

### Digital Section (Master only):

I/O connectors	XLR (2 channels AES/EBU in). 3 x RJ45 proprietary TC LINK
Formats	AES/EBU
Word clock	Input BNC, 75Ω, 0.6 to 10 Vpp
Display	2 x 16 character dot matrix
Operation	Menu system / four buttons

### Analogue Section (Master only):

Input connectors	XLR balanced (pin 2+, pin 3-)
Impedance	10/3 kΩ (balanced/unbalanced)
Selectable Full Scale Input level	+9, +15, +21, +27 dBu
Dynamic Range	> 113 dB typ. (unweighted), BW: 20-20kHz
THD+N	< -105 dB typ. @ 1 kHz, -3 dBFS
Cross-talk	< -120 dB, 20 Hz to 20 kHz

### A to D Conversion

24 bit (Dual bit delta sigma sampling at 4.1/5.6/6.1/6.1MHz)

### Slaves Only:

I/O connector's	2 x RJ45 proprietary TC LINK
-----------------	------------------------------

The typical listening distance for **Precision 8 iDP™** is 1.3 -2.8m. The typical room size for **Precision 8 iDP™** is 50 -100 m3

### NOTES

<sup>(1)</sup> +/- 3 dB, measured at 1m in an anechoic chamber. <sup>(2)</sup> Peak SPL at mix position for 1 pair driven.

Tannoy operates a policy of continuous research and development. The introduction of new materials or manufacturing methods will always equal or exceed the published specifications which Tannoy reserve the right to alter without prior notice. Please verify the latest specifications when dealing with critical applications.



## PRECISION 6

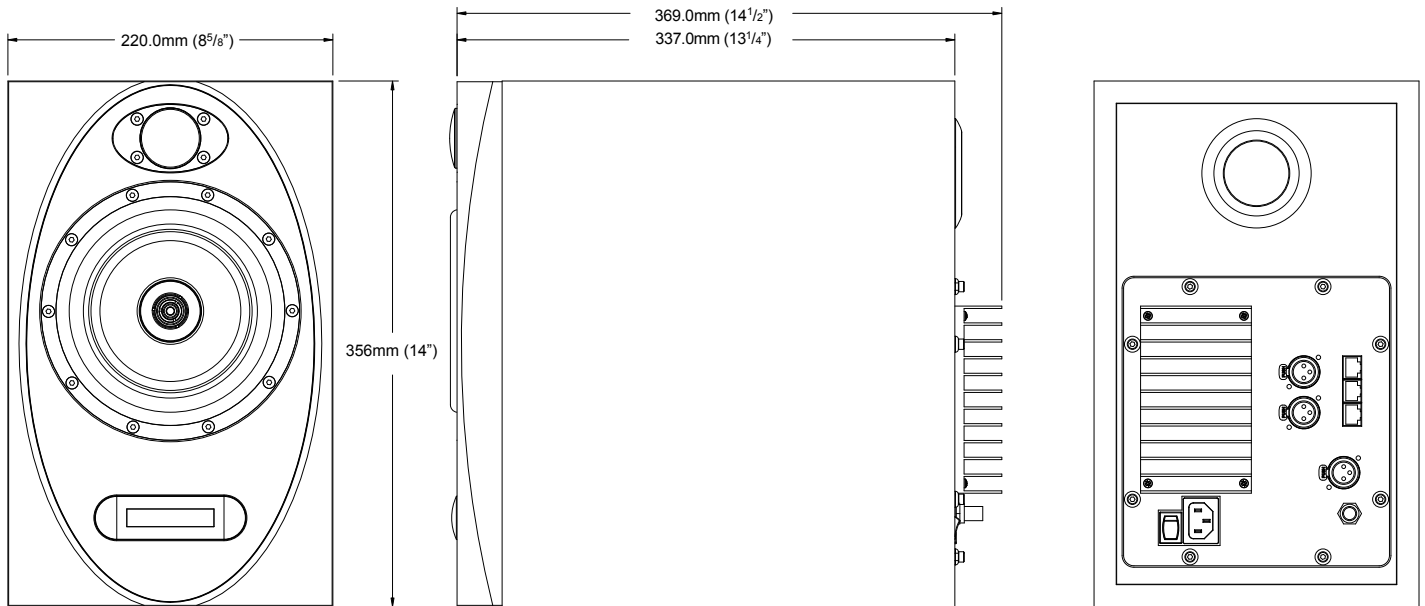

# PRECISION

## PRECISION 8

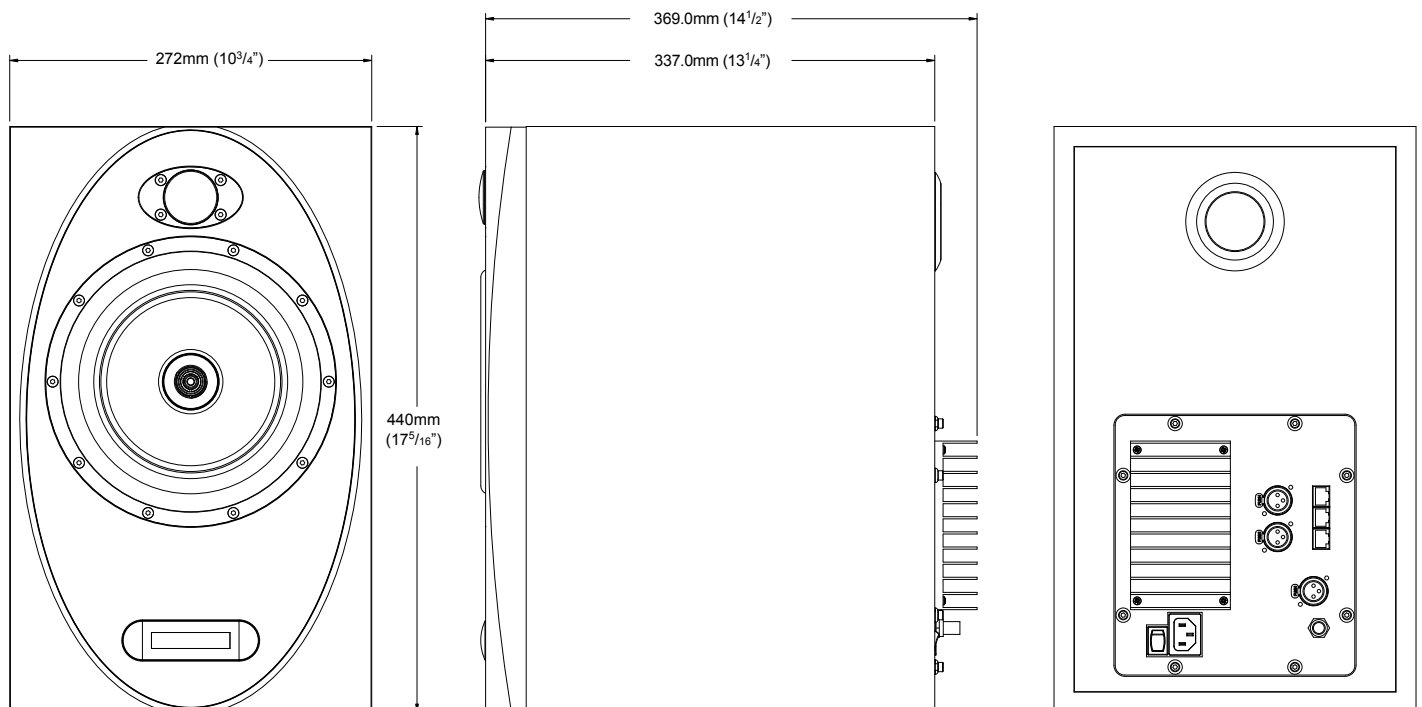

**Dimensions : Precision TS212 iDP™ (Grey/Silver inlay top plate)**

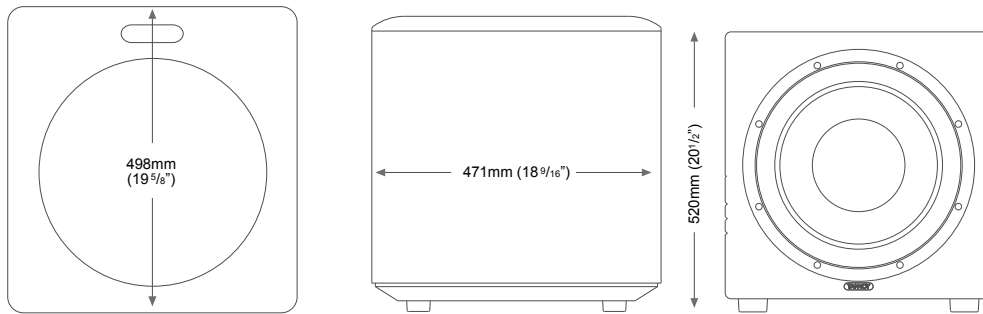

**Dimensions : Precision TS112 iDP™ (Grey)**

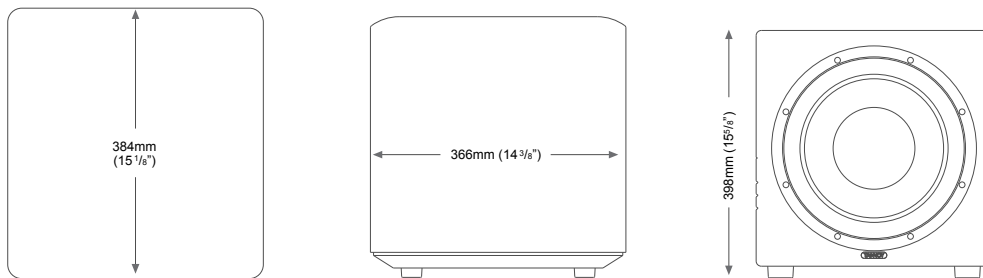

**Technical Specifications**

**System**

Frequency Response  
 Max. SPL (@ 1m)  
 Crossover Frequency  
 Drive units  
 Cabinet Volume/LF Alignment  
 Dimensions (H x W x D)

**TS212 iDP™ Subwoofer**

Active Subwoofer  
 25Hz – 150Hz (+/- 3dB)  
 124dB (continuous)  
 Set in bass management (DSP Generated)  
 2 x 300mm (12") Aluminium Cone  
 45 Litres/Infinite baffle  
 520mm x 471mm x 497mm  
 (20<sup>1</sup>/<sub>2</sub>" x 18<sup>5</sup>/<sub>8</sub>" x 19<sup>5</sup>/<sub>8</sub>" )

**TS112 iDP™ Subwoofer & iDP5™**

Active Subwoofer  
 25Hz – 150Hz (+/- 3dB)  
 118dB (continuous)  
 Set in bass management (DSP Generated)  
 1 x 300mm (12") Aluminium Cone  
 22 Litres/Infinite baffle  
 384mm x 366mm x 398mm  
 (15<sup>1</sup>/<sub>8</sub>" x 14<sup>3</sup>/<sub>8</sub>" x 15<sup>5</sup>/<sub>8</sub>" )

**Cabinet Construction**

Total weight

MDF  
 Grey suede paint finish on top with silver top plate.  
 Black fabric on sides  
 Black anodised aluminium back plate.  
 51kg (112.2lbs)

MDF  
 Grey suede paint finish.  
 Black anodised aluminium back plate.  
 25kg (55lbs)

**Electronic System**

Mains Voltage  
 Power Consumption  
 Amplifier

115 or 230Vac, 50 – 60Hz (switchable)  
 45W @ <sup>1</sup>/<sub>8</sub> Full Power (IEC 60065)  
 1500 W PWM amp

115 or 230Vac, 50 – 60Hz (switchable)  
 45W @ <sup>1</sup>/<sub>8</sub> Full Power (IEC 60065)  
 750 W PWM amp

**System Sample Rates:**

Internal

96 kHz (except when slaved to digital input or word clock input)  
 96, 88.2, 64, 48, 44.1 or 32 kHz (optional 192kHz)

96 kHz (except when slaved to digital input or word clock input)  
 96, 88.2, 64, 48, 44.1 or 32 kHz (optional 192kHz)

External

**Digital Section (Slave only):**

I/O connectors  
 Dynamic Range  
 THD+N  
 Crosstalk  
 A to D Conversion

2 x RJ45 proprietary TC LINK  
 > 113 dB typ. (unweighted)  
 < -105 dB typ. @ 1 kHz, -3 dBFS  
 < -120 dB  
 24 bit (Dual bit delta sigma sampling at 4.1/5.6/6.1/6.1 MHz)

2 x RJ45 proprietary TC LINK  
 > 113 dB typ. (unweighted)  
 < -105 dB typ. @ 1 kHz, -3 dBFS  
 < -120 dB  
 24 bit (Dual bit delta sigma sampling at 4.1/5.6/6.1/6.1 MHz)





accuracy through precision



**PRECISION** IDP  
ACTIVE STUDIO MONITORS TECHNOLOGY

**DUAL**<sup>TM</sup>  
CONCENTRIC

**WIDEBAND**<sup>TM</sup>  
TECHNOLOGY

Tannoy United Kingdom	T: +44 (0) 1236 420199	F: +44 (0) 1236 428230	E: enquiries@tannoy.com
Tannoy North America	T: (519) 745 1158	F: (519) 745 2364	E: inquiries@tannoyna.com
Tannoy Deutschland	T: 0180 1111 88 1	F: 0180 1111 88 2	E: info@tannoy.com

Tannoy adopts a policy of continuous improvement and product specification is subject to change.

tannoy.com