

CC3701H-2 Series Digital CCD Color Camera

1/3-INCH, HIGH RESOLUTION WITH EDR, 480 TVL (NTSC/PAL)

Product Features

- Sony SuperHAD™ Technology
- EDR (Extended Dynamic Range)
- 1/3-Inch Format CCD Imager
- C/CS Lens Mount
- DC/Video Drive Auto Iris Lens Compatibility
- 24 VAC/12 VDC Power
- Line Lock With Phase Adjustment
- Automatic Gain Control (AGC)
- Backlight Compensation
- Electronic Iris
- Horizontal Resolution of 480 TV Lines
- Digital Signal Processing
- Low Profile Top/Bottom Mount
- Optional Integral Feedthrough Mount

The **CC3701H-2 Series** is a high-resolution, high sensitivity, general purpose digital camera with 480 TV lines. The camera features two color balance settings, automatic gain control, digital signal processing, automatic backlight compensation, and line lock. To adjust one of the camera's many fine-tuning features, just reset the corresponding DIP switch, readily available on the left side of the camera.

Utilizing innovative technology (patent pending), the **CC3701H-2 Series** camera provides an extended dynamic range over conventional high resolution cameras, without sacrificing sensitivity, color imagery, or resolution. Extended dynamic range (12X) allows the camera to provide a picture in many extreme light applications.

The **CC3701H-2 Series** digital color camera is smaller than most other full-featured CCD cameras. In order to keep the camera as small as possible, Pelco engineers designed the camera components to fit within the external dimensions of the unit. Since the BNC, power, and lens connectors stay within the boundaries of the case, the compact camera and a lens fit perfectly inside one of Pelco's smaller enclosures (EH100, EH3508, EH2508, EH2020, EH2100, and EH2200). Pelco also has a wide selection of fixed and varifocal lenses available to meet your installation requirements.



(REAR COVER REMOVED)

CAMERA MOUNTED ON
PCM100 CAMERA MOUNT

(LENS AND MOUNT NOT SUPPLIED WITH CAMERA)

The **CC3701H-2 Series** digital camera also includes Sony's latest generation of 1/3-inch CCD imagers, accepts DC and video drive auto iris lenses, and has adjustable back focus to accommodate C or CS lenses. Back focus adjustment is easy with the lockable thumb wheel, accessible from the top or bottom of the camera.

The **CC3701H-2 Series** digital camera is quick and easy to install, and its distinctive design is ideal for use in confined spaces. The camera has a quick-connect power connection, BNC video connector, and a removable mount adapter for top or bottom mounting.

Accessories include the PCM100 camera mount designed specifically for the **CC3701H-2 Series**. This adjustable mount has no exposed cabling or hardware. All cable is integrated in the unit making installation quick and easy. The PCM100 can be installed directly to a wall or ceiling, or it can be adapted to a standard 2 x 4-inch (5.08 x 10.16 cm) electrical box.



C1937 / REVISED 5-23-08



U.S. Patent 0460,773

International Standards
Organization Registered Firm;
ISO 9001 Quality System



TECHNICAL SPECIFICATIONS

MODELS

CC3701H-2	1/3-inch high resolution digital color CCD camera, 480 TVL, NTSC format
CC3701H-2X	Same as CC3701H-2 except PAL format

GENERAL

Imaging Device	1/3-inch interline transfer CCD
Picture Elements	
CC3701H-2	768 (H) x 494 (V)
CC3701H-2X	752 (H) x 582 (V)
Scanning System	
CC3701H-2	525 lines, 2:1 interlace
CC3701H-2X	625 lines, 2:1 interlace
Synchronization System	
CC3701H-2	Internal or line lock
CC3701H-2X	Internal or line lock
Horizontal Resolution	480 TV lines
Iris Control	Electronic/passive
Minimum Illumination	0.5 lux, f1.2, 40 IRE, AGC on, 75% reflectance
Signal-to-Noise Ratio	52 dB
Gain Control	Automatic
Vertical Phase	Adjustable 0° ±120°
Automatic Gain Control	Selectable by DIP switch
Backlight Compensation	Selectable by DIP switch
Signal Processing	DSP
Auto Iris Lens Type	DC/video control
Video Output	1 Vp-p, 75 ohms
Iris Control Range	1/60-1/100,000 second
Auto White Balance Range	2,500° to 9,500°K

ELECTRICAL

Power Requirements	18-30 VAC or 10-36 VDC
Power Consumption	Less than 4 watts
Power Connector	2-pin terminal strip, push-in type, with screw lock
Video Connector	BNC
Lens Jack	4-pin connector (miniature square)

MECHANICAL

Lens Mount	C/CS mount (adjustable)
Camera Mount	1/4-inch UNC-20 screw, top and bottom of camera housing

ENVIRONMENTAL

Operating Temperature	14° to 122°F (-10° to 50°C)
Storage Temperature	14° to 158°F (-10° to 70°C)

PHYSICAL

Weight (without lens)	0.77 lb (0.35 kg)
Shipping Weight	2 lb (0.9 kg) approximate

CERTIFICATIONS/PATENTS

- CE, Class B
- FCC, Class B
- UL/cUL Listed
- Complies with Argentina compliance requirements under Res. 92/98
- U.S. Patent D460,773
- CQC (China Quality Certification)

RECOMMENDED MOUNTS

BS1750/CM1750/ CM1750S/TB1750	Adjustable swivel head camera mounts for wall, ceiling, or pedestal mounting.
C10-UM	C10 series universal wall/ceiling/rail mount kit
PCM100	Adjustable camera mount for wall or ceiling application. Includes integrated cable for easy plug and play operation. Can also be adapted to a standard 2 x 4-inch (5.08 x 10.16 cm) electrical box.

RECOMMENDED POWER SUPPLIES

TF2000	Power supply for one 24 VAC camera, 20 VA.
MCS Series	Multiple 24 VAC camera power supply, indoor.
WCS Series	Single/multiple 24 VAC camera power supply, outdoor

RECOMMENDED LENSES

13FA, FD Series	Fixed focal length lenses, 1/3-inch format. FA (manual iris); FD (auto iris, DD).
13VA, VD Series	Varifocal lenses, 1/3-inch format. VA (manual iris); VD (auto iris, DD).
13ZD Series	Motorized zoom lenses, 1/3-inch format (auto iris, DD).

LENS ACCESSORIES

LDC100	Auto iris drive converter. Converts a DC-drive auto iris lens to a video drive auto iris lens. Compatible with all lens size formats.
--------	---------------------------------------------------------------------------------------------------------------------------------------

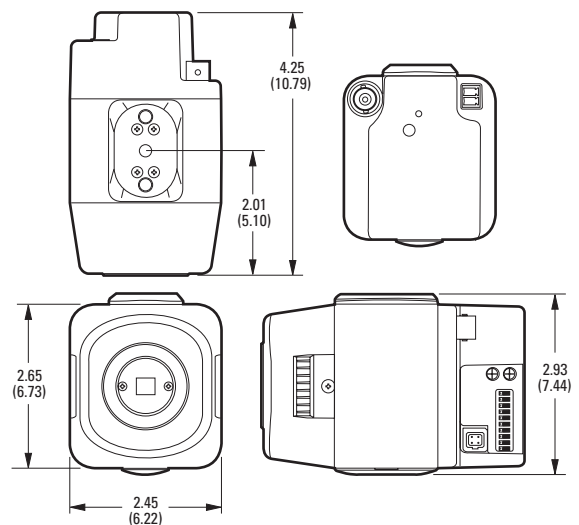

NOTE: VALUES IN PARENTHESES ARE CENTIMETERS; ALL OTHERS ARE INCHES.

NOTE: For outdoor camera installations, a Pelco enclosure is recommended.



Pelco, Inc. Worldwide Headquarters:
3500 Pelco Way, Clovis, California 93612-5699 USA
USA & Canada Tel: (800) 289-9100 • FAX (800) 289-9150
International Tel: +1 (559) 292-1981 • FAX +1 (559) 348-1120
www.pelco.com

Pelco and the Pelco logo are registered trademarks of Pelco, Inc.
SuperHAD is a trademark of the Sony Corporation.
Product specifications and availability subject to change without notice.
©Copyright 2008, Pelco, Inc. All rights reserved.