

ALTMAN
Lighting, Inc.

ALTMAN Q-LITE OPEN FACE FIXTURE

These open-face luminaires are compact, lightweight, multipurpose flood/fill lights ideal for stage, studio and location lighting applications. Designed to operate high color-temperature tungsten halogen lamps, they are well suited for use in tight or confined spaces where maximum light output and beam spread are required for fill or flood lighting. The Q-Lite is rated for up to 1000W lamps, and the Q-Lite Jr. is rated for up to 650W. 36" Power lead. Lamps not included.



ITEM	DESCRIPTION	PRICE
Q-LITE.....	1000W open face fixture	176.25
Q-LITE-JR.....	650W open face fixture	157.50
QL-BD4.....	Barn door for Q-LITE.....	33.00
QL-JR-BD4.....	Barn door for Q-LITE-JR.....	27.75
FCM-EIKO.....	1000W, 3200K lamp.....	6.29

ELATION

**ELATION LIGHTING
TVL3000 II LED TV/BROADCAST LIGHT**

This fixture features (24) 3W white LEDs, flicker-free dimming, convection cooling, an included beam angle lens kit (10°, 25°, 40°, 60°), manual and 1-channel DMX operation modes, adjustable barn doors, Powercon in/out, and a max. power consumption of 70W. Works great as a replacement for keylights and headlights.



Please contact your Sales Pro to discuss available mounting bracket accessories.

ITEM	DESCRIPTION	PRICE
TVL-3000-II/CW.....	5000K Cool White LED broadcast light.....	1199.99
TVL-3000-II/DW.....	3200-5600K Variable/Dynamic White version.....	1199.99
TVL-3000-II/WW.....	3200K Warm White version	1199.99
TVL3BAT.....	Rechargeable battery back for 2x TVL3000 II.....	899.99

BOWENS

BOWENS GEMINI 750PRO (X2) KIT

This two-head studio lighting kit is great for beginning photographers or those looking for a versatile kit with plenty of accessories. Includes (2) Gemini 750Pro lights, a Pulsar Radio Trigger and Receiver Card, a 60x80 cm softbox, 90cm umbrella, a 120° wide angle reflector, (2) stands, (2) flash tubes, (2) power cords, (2) lamps, a sync lead, and a rolling case.



ITEM	DESCRIPTION	PRICE
BW-8710TXUS.....	Two-head Gemini 750Pro Lighting Kit.....	2099.00

BOWENS GEMINI 400RX KIT

This two-light kit is great for photographers at every level of expertise and works well in studios and on location. Includes (2) Gemini 400Rx flash heads with built-in Pulsar Radio Receivers, a Pulsar Tx Radio Trigger, (2) 90cm umbrellas, (2) wide angle reflectors, (2) stands, a carry case, 250W modelling lamps, cables, and a sync cord. Features include fast 1.2s recycling, 1/1000s quick flash duration (both onboard features), and a full 5-stop flash power range that also controls the proportional modelling lamp.



ITEM	DESCRIPTION	PRICE
BW-4765TXUS.....	Two-light Gemini 400Rx Kit.....	849.00

BOWENS PORTRAIT REFLECTOR KIT

Designed specifically for portrait lighting applications, this kit includes a 60x80cm softbox, a 60° grid reflector, an 81 cm gold/silver reflector disc, (3) sizes of honeycomb grid, a back light reflector, 12 colored gels and filters, and a telescopic backlight stand.



ITEM	DESCRIPTION	PRICE
BW-6655.....	Portrait lighting accessory kit.....	595.00

ikan

IKAN SL120 STUDIO LED LIGHT The SL120 is outfitted with 120 high-intensity "Cree"-style emitters which provide a high color rendering index of 91, making it a great choice for studio use. Features of particular note include barn doors with Intensifiers, DMX 512 control of onboard dimmer and an aluminum heat sink to cool the unit. A yoke mount is included.



ITEM	DESCRIPTION	PRICE
SL120.....	Studio LED Light Fixture.....	2159.00

Litepanels

LITEPANELS INCA™ LED FRESNELS

These DMX-controllable tungsten-balanced fixtures are for use in applications where LED lighting needs to match existing incandescent (or other equally warm) lights. The Inca's controllability and light-shaping properties are similar to those of the average Fresnel, but they consume less power and weigh less. They offer 100%-0% dimming with no noticeable color shift via on-fixture dial or integrated DMX. Includes standard yoke, power supply, and barn door. Gels, carrying bag and other accessories are sold separately – please contact your Sales Pro.



ITEM	DESCRIPTION	PRICE
906-4003.....	Inca 4, 4" tungsten LED Fresnel.....	999.00
906-2003.....	Inca 6, 6" tungsten LED Fresnel.....	1796.00

Litepanels

LITEPANELS MICRO ON-CAMERA LED LIGHTS

A compact lighting tool for small DV camcorders, the Micro™ uses LED technology in an ultra-lightweight package. Operators will enjoy luminous, soft, directional lighting with the same warmth and great color characteristics that make Litepanels an integral part of television, broadcast news and feature production. The top-mounted dimming knob is ideal for DV and DSLR cameras. Micro™ runs off 4 standard AA batteries, MicroPro™ doubles the light output, uses 6 standard AA batteries and includes a carrying bag.



ITEM	DESCRIPTION	PRICE
905-1002.....	25W on-camera LED light, ball head shoe mount, gels.....	198.00
905-2022.....	50W on-camera LED light, ball head shoe mount, gels, carrying bag.....	315.00

- AUDIO
- VIDEO
- COMPUTER AV
- LIGHTS
- ACCESSORIES

Shop fullcompass.com today!

For expert advice - call: 800-356-5844

M-F: 9:00-5:30 Central





Litepanels

NEW!

LITEPANELS ASTRA 1X1 BI-COLOR

This one-square foot, tunable daylight-to-tungsten panel uses high-performance LEDs with custom-paired optics to offer enhanced color reproduction and output that is up to four times brighter than traditional LED fixtures. Illuminates a wider area and provides a longer throw. Features also include ultra-smooth dimming with no noticeable color shift from 0-100%, flicker-free output at any frame rate or shutter angle, and dual user-selectable (active/passive) cooling modes. Optional control module offers DMX functionality.



ITEM	DESCRIPTION	PRICE
935-1003	ASTRA 1x1 Bi-Color	1350.00
900-3501	ASTRA 1x1 DMX control module	270.00

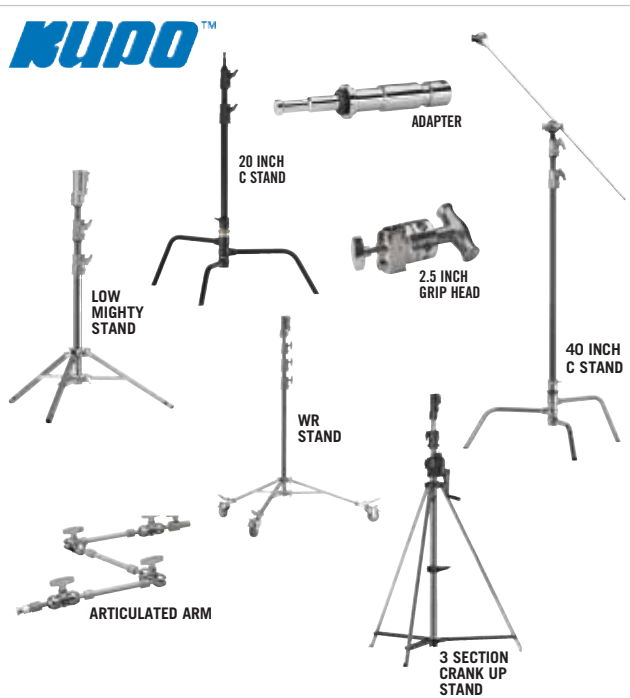

KUPO™ PROFESSIONAL LIGHTING SUPPORT AND GRIP EQUIPMENT

ITEM	DESCRIPTION	PRICE
KS743712	40" C Stand, Turtle Base, Kit, Chrome	176.50
KS742512	20" C Stand, Turtle Base, Chrome	131.00
KS742811	20" C Stand, Turtle Base, Black	124.43
KS743512	20" C Stand, Turtle Base, Kit, Chrome	182.50
KS743611	20" C Stand, Turtle Base, Kit, Black	178.00
KS300312	Low Mighty Stand	204.00
KG500112	Master Cine Stand	220.00
KS500412	Master High Cine Stand	240.00
KG600112	High Overhead Roller Stand	370.00
KS300112	High Roller Stand	285.50
KS300712	Junior Roller Stand	198.75
KS401212	3 Section Crank Up Stand	560.50
KG203012	2.5" Grip Head - Chrome	24.25
KG203111	2.5" Grip Head - Black	24.00
KG203212	20" Grip Arm - Chrome	30.00
KG203311	20" Grip Arm - Black	29.25
KG203412	40" Grip Arm - Chrome	34.00
KG203511	40" Grip Arm - Black	34.00
KG300512	Articulated Arm	72.95
KD2302112	Baby Drop Ceiling Adapter - 5/8" Stud	10.00
KG006312	Adapter 1-1/8" stud to 5/8" Stud	15.00
KG2004611	5/8" Receiver w/ 3/8" -16 Thread	10.25
KG005412	TVMP Adapter	11.00
KG083411	25 lbs Velcro Sandbag - Empty	26.00
KG083311	35 lbs Velcro Sandbag - Empty	32.75

lowel

NEW!

LOWEL PRO™ POWER LED 2 + 3 LIGHT KITS

For "run and gun" location lighting, Lowel's PRO Power LED Series Lighting Kits offer wide focus range Fresnel lenses and powerful output; allowing you to light from greater distances in order to get more of your location into your shot. The G5-92 series kits come with 2 light fixtures and accompanying stands, a Tota-brella, and case (hard or soft); the G5-93 series adds 1-light and stand (total of 3 each), LED Softbox light attachment, accessory gel set, and gel frame (hard case standard).



ITEM	DESCRIPTION	PRICE
G5-92DA	2-Light LED Daylight AC Kit with hard case	1513.34
G5-92DALB	As above, with soft case	1425.36
G5-92TU	2-Light LED Tungsten AC Kit with hard case	1513.34
G5-92TULB	As above, with soft case	1425.36
G5-93DA	3-Light LED Daylight AC Kit	2252.43
G5-93TU	3-Light LED Tungsten AC Kit	2252.43

LOWEL PRIME LOCATION™ LEDS

NEW!

Lowel's most rugged LED system yet, the Prime Location™ LED light fixtures are sturdy, highly weather resistant, and feature high output. Manually dimmable with no color shift, with quiet fanless operation that comes in these color options: Tungsten, Daylight, and BiColor (Tungsten/Daylight). Included standard with the light fixtures is a gel frame, battery mount plate (V-Lock or Gold Mount options), safety cable, female stand fitting, and 16' AC switched AC cable (PCI-810). Prime Location 1 or 2 light kits are also available.



ITEM	DESCRIPTION	PRICE
PL-01ADA	LED Daylight Fixture, with Gold Mount battery plate	1510.64
PL-01ATU	LED Tungsten Fixture, as above	1510.64
PL-01VDA	LED Daylight Fixture, with V-Lock battery plate	1510.64
PL-01VTU	LED Tungsten Fixture, as above	1510.64
PL-01ABC	LED BiColor Fixture, with Gold Mount battery plate	1618.93
PL-01VBC	As above, with V-Lock battery plate	1618.93
PL-91ADA	LED Daylight 1-Light Kit, with Gold Mount battery plate	1759.71
PL-91ATU	LED Tungsten 1-Light Kit, as above	1759.71
PL-91VDA	LED Daylight 1-Light Kit, with V-Lock battery plate	1759.71
PL-91VTU	LED Tungsten 1-Light Kit, as above	1759.71
PL-91ABC	LED BiColor 1-Light Kit, with Gold Mount battery plate	1864.76
PL-91VBC	As above, with V-Lock battery plate	1864.76
PL-92ADA	LED Daylight 2-Light Kit, with Gold Mount battery plate	3439.85
PL-92ATU	LED Tungsten 2-Light Kit, as above	3439.85
PL-92VDA	LED Daylight 2-Light Kit, with V-Lock battery plate	3439.85
PL-92VTU	LED Tungsten 2-Light Kit, as above	3439.85
PL-92ABC	LED BiColor 2-Light Kit, with Gold Mount battery plate	3384.06
PL-92VBC	As above, with V-Lock battery plate	3384.06
PL-120	Prime Location Barndoor Softening Set	193.30
PL-132	Prime Location 20° Honeycomb grid	151.61
PL-133	Prime Location 30° Honeycomb grid	136.44

LOWEL TOTA-LIGHT BROAD SOURCE

Exceptionally wide-angle halogen source. Gull-wing reflector produces smooth, efficient light pattern. Watts: 750, 650, 500 and 300 at 120V; 800 at 220/240V. Light controls: umbrella, gel frame, flags, etc. Mounting system: stand, wall/door mount, clamps. Protective front screen. Closes compactly for storage and travel.



ITEM	DESCRIPTION	PRICE
T1-10	Tota-light with 16' AC cable	140.24



Follow Us!

Let us show you exactly what to expect with our lighting design computer modeling and pre-visualization.

lowel

LOWEL PRO-LIGHT, I-LIGHT

Portable lights for both AC and battery power. Features interchangeable reflectors, focus capability, inexpensive halogen lamps and a wide variety of accessories, including swing-away accessory holders. #2 (IP-17) re-lector and Prismatic glass (IP-52) is included.



ITEM	DESCRIPTION	PRICE
P2-10	Pro-light, 120V AC 50-250W, 4' cable, 12' extension cable, stand link	133.42
I-01	I-Light 12-14V, with 55W and 100W lamp, 4' cable with cigarette lighter plug, Low link, Cam-link, VIP Stand link and focus knob extension	174.34
I-02	I-Light with 4-pin XLR connector	174.34
I-045	I-Light with Anton-Bauer tap	174.34
ID-01	ID-Light like i-Light with dimmer	284.27
ID-02	ID-Light with 4-pin XLR connector	284.27
ID-045	ID-Light with Anton Bauer tap	284.27



RIFA-44

LOWEL RIFA-LITE For beautiful soft key or fill lighting. Compact, lightweight and self-contained. Woven glass front diffuser with exceptional heat resistance.

ITEM	DESCRIPTION	PRICE
LC-44EX	Rifa-Lite 250W 16"x16"	356.27
LC-44EC/50	Egg crate for LC-44	151.02
LC-55EX	Rifa-Lite 500W 21"x21"	515.47
LC-55EC/40	Egg crate for LC-55	199.99
LC-66EX	Rifa-Lite 750W 25"x25"	598.84
LC-66D	Baffle for LC-66	144.48
LC-66EC/40	Egg Crate for LC-66	236.74
LC-88EX	Rifa-Lite 1000W 32"x32"	686.01
LC-88D	Baffle for LC-88	167.34
LC-88EC/40	Egg Crate for LC-88	285.71

Manfrotto

proven professional

MANFROTTO SPECTRA 1X1 FAMILY

Daylight balanced LED panels with full spectrum output; these units give flattering soft light with excellent color rendition and high fidelity color reproduction. These sturdy panels offer extreme portability with their slim, lightweight design, and dual-power (AC or professional battery) ability. Wide and narrow beam angle versions are available, all with adjustable light intensity. Careful design, with emphasis on reliability and consistent flicker-free functionality, plus only the highest quality LEDs, ensure solid performance. Fully tested to comply with all mandatory standards and regulatory requirements.



NEW!

ITEM	DESCRIPTION	PRICE
MLS1X1F	Spectra 1x1 F-LED-1400lux, 5600K, Flood, Dimmable	999.99
MLS1X1FT	Spectra Bi-Color-LED-1400lux, as above	1789.99
MLS1X1S	Spectra 1x1 S-LED-1700lux, 5600K, Spot, Dimmable	999.99

SEKONIC®

SEKONIC L-758CINE DIGITALMASTER

Offering the most extensive range of fps (frames-per-second), cine shutter speeds, and shutter angle settings, the Sekonic L-758Cine DigitalMaster meets the demands of professionals. Sekonic has automated the process of understanding the dynamic range of your camera and calibrating your meter to work with it. This process requires recording images of one of Sekonic's Exposure Profile Targets or one of X-Rite's ColorChecker series targets, available as a separate purchase. Once recorded, the processed TIFF or JPEG image files are imported into Sekonic's DTS software for processing and mapping. Measured data from industry-standard targets can also be entered manually.



After processing, a USB cable is used to transfer the data to one of the Sekonic L-758 meters. Up to 3 camera profiles can be stored in the meter. Any number of profiles can be stored with the software. Once loaded, the Sekonic L-758Cine makes incident and reflected-light spot readings that are precisely tuned to the dynamic range of the profiled camera.

ITEM	DESCRIPTION	PRICE
401-760	L-758Cine DigitalMaster light meter	822.00



SEKONIC L-478D LITEMASTER PRO

The world's first touch-screen-operated light meter, the L-478D LiteMaster Pro has unique features for both still and motion story tellers. It's compact in size yet comfortable to use. The large 2.7" LCD displays ambient, flash, cine and a host of other information in a clear and understandable way. Settings are made by simply touching or sliding a finger over the screen. The L-478D can be quickly calibrated to your camera using Sekonic's Data Transfer software and either Sekonic or X-Rite Brand targets or by manually inputting

data to the DTS program or on the meter itself.

ITEM	DESCRIPTION	PRICE
401-478	L-478D LiteMaster Pro light meter	339.00

SMITH VICTOR

SMITH VICTOR DIGILIGHT FLUORESCENT LIGHT KIT

This 1050W 3-light kit includes (3) DigiLight FL3 fluorescent lights, (9) 26W spiral fluorescent lamps, an MB110 mini boom arm, (3) Raven RS8 8 ft black aluminum light stands, and a lighting guide. The fixtures' reflectors are chemically etched for maximum light dispersion.



ITEM	DESCRIPTION	PRICE
KFL-33	3-light fluorescent lighting kit w/lamps, stands, etc.	399.00

Shop fullcompass.com today!

For expert advice - call: 800-356-5844

M-F: 9:00-5:30 Central



- AUDIO
- COMPUTER AV
- VIDEO
- LIGHTS
- ACCESSORIES

AUDIO



SMITH VICTOR K78 PROFESSIONAL PORTRAIT LIGHTING KIT

This kit consists of (2) 765UM 600W quartz lights, (1) 750SG 1,000W quartz Broad Light, (2) Raven RS8 8' black aluminum light stand, (1) Raven RS13 13' air-cushioned black aluminum light stand, (1) MB150 boom arm, (1) 45" black-backed white umbrella, on DYH 600W quartz lamp, (1) FHM 1,000W quartz lamp, (1) EYH 250W quartz lamp, (1) SBC1236 12"x36" strip soft box with mounting bracket, (1) wheeled soft case and (1) Imaging with Light lighting guide.



ITEM	DESCRIPTION	PRICE
K78	Professional portrait kit	849.00



SMITH VICTOR KSB-1250 ECONOMY SOFTBOX LIGHT KIT

This softbox kit includes (2) SBL-2432 economy softbox lights, (1) SBL-1236 economy softbox light, (2) 500W ECT 3200K photoflood lamps, (1) 250W ECA 3200K photoflood lamp, (3) Raven RS8 8 ft black aluminum light stands, (1) MB110 mini boom arm, and a lighting guide. The softboxes feature a silver metallic lining inside for maximum brightness as well as a diffusion panel.

ITEM	DESCRIPTION	PRICE
KSB-1250	3-light softbox light kit	585.00

SMITH VICTOR KT900 PHOTOFLOOD KIT

This 1250W 3-light kit is great in a variety of applications and features (2) 12" reflectors with punch-out holes, (1) 5" reflector, (3) socket and cord sets with 5/8" stand mounts, (2) umbrella mounts, (2) 32" umbrellas, (2) 500W ECT photoflood lamps, (1) 250W ECA photoflood lamp, (3) Raven RS8 8 ft aluminum light stands, (1) MB110 mini boom arm, (1) wheeled soft case and a lighting guide.



ITEM	DESCRIPTION	PRICE
KT900	3-light photoflood kit	275.00



WESTCOTT ILLUSIONS PHOTO GREEN SCREEN SOFTWARE BUNDLE (LITE)

This kit includes a 5'x7' wrinkle-resistant X-Drop green screen, PhotoKey Lite Software, (200) digital backdrops, (20) overlay graphics, and (2) wall hooks. Great for every level of expertise of photographer/photo editor.



ITEM	DESCRIPTION	PRICE
417N	Green screen with digital backgrounds and software	49.90



WESTCOTT GREEN SCREEN X-DROP BACKDROP KIT

Designed for quick set-up and teardown, this 5'x7' green screen backdrop has telescoping legs and arms and is machine washable. Grommets along the top and bottom make hanging the backdrop easy and ensure that it remains taut. Includes a carry case that allows you to transport three additional backdrops.



ITEM	DESCRIPTION	PRICE
579K	5'x7' green screen backdrop with mounting stand and case	119.90

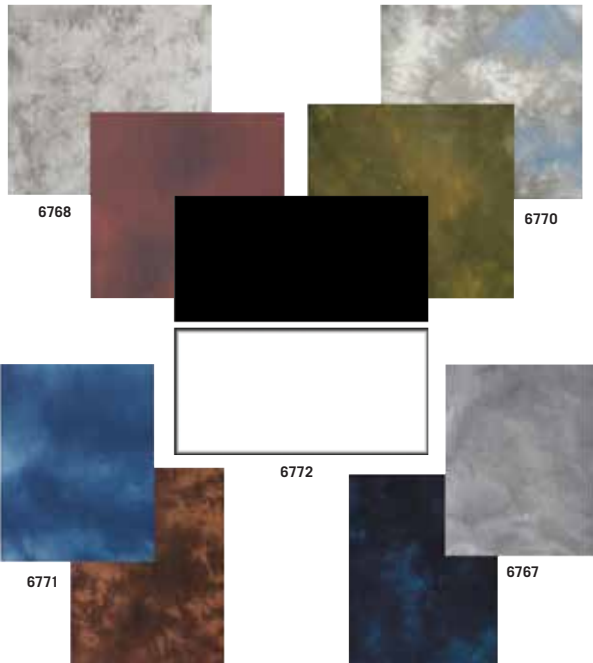

WESTCOTT TWO-SIDED BACKDROPS

Two-sided collapsible background gives the user two color choices in one bag. Includes two straps along the top edge for easy hanging and round, clear PVC carry case. All backgrounds are 6'x7'.

ITEM	DESCRIPTION	PRICE
6771	Rich Mocha/Heavenly Blue	219.90
6767	Smokey Gray/Midnight Blue	219.90
6770	Bracken Brown/April Showers	219.90
6768	Autumn Red/Pearl	213.63
6772	Black/White	219.90



WESTCOTT BACKGROUND SUPPORT SYSTEM

The Background Support System uses two 10' H air-cushioned stands with a three-section cross bar that extends up to 10.5". The system also allows for mounting a second crossbar and background. Includes carry case.



ITEM	DESCRIPTION	PRICE
9014	Background support system	199.90



Follow Us!

Let us show you exactly what to expect with our lighting design computer modeling and pre-visualization.

arKaos

ARKAOS MEDIAMASTER PRO 4 This software allows you to create projection mappings on any surface, manage and map DMX devices, and connect your installations through its server functionality. Additional features include automatic output detection, the ability to project across multiple outputs and onto a wide variety of surfaces, integrated cropping, snapping, pixel displacement, angle vectoring, and real-time visualization. Version 4 brings in extended fixture profile with over 70 parameters per layer, DMX-controlled cropping, image color controls, per-layer aspect ratio/audio volume/pan controls, pause function and redesigned interface. The Video Mapper allows quick and easy setup of visuals to flow around complex objects, plus surface grouping/masking/cropping and more.

ITEM	DESCRIPTION	PRICE
AKMEDIAMPRO	Professional media mapping/server software, Version 4	2410.80



ChamSys

CHAMSYS MAGICQ COMPACT LIGHTING CONSOLES

These highly durable and portable DMX lighting consoles meet carry on requirements for all major airlines. They have a built-in touchscreen for easy control and support 4 DMX universes (up to 12 with MQ60/70) with 4 direct DMX outputs on the rear panel. Features flexible GUI lighting control, media server connectivity, full featured theatre stacks, LED pixel mapping, and fixture morphing and cloning. Uses the same software and show formats as all consoles in the MagicQ range, enabling cross compatibility between them. MQ60 and MQ70 include an internal Ethernet switch and built-in UPS. MQ70 also has 1GHz ChamNet network port and POE.

ITEM	DESCRIPTION	PRICE
MQ40	4-universe compact DMX lighting control console	CALL
MQ60	As above, with 12-universes, internal Ethernet and UPS	CALL
MQ70	As above, with 1GHz ChamNet network port and POE	CALL



CHAMSYS MAGICQ PC WING COMPACT Connects to Windows or Mac PC via USB to control lighting, video and LED with MagicQ software. Enables easy access to moving light parameters via 8 rotary encoders and show controls via 12 faders, 2 fully patchable direct DMX outputs are also included. It is improved from the original PC Wing

with a narrower form as well as six additional buttons: previous page, group and 4 layout/macro buttons. A power supply, USB hub and audio input are built-in and it includes a dimmable LED desk lamp. Supports up to 64 universes and shows can be transferred to other MagicQ consoles over a network or USB stick.

ITEM	DESCRIPTION	PRICE
PC-WING	Lighting controller for PC (Mac/Win)	CALL



CHAMSYS MAGICQ MAXI WING Connects to Windows or Mac PC via USB to control lighting, video and LED with MagicQ software. Enables easy access to moving light parameters via 8 rotary encoders and show controls via 13 faders, 4 fully patchable direct DMX

outputs are also included. It is the top of the range of MagicQ USB wings and includes all of the faders, buttons and encoders found on full MagicQ consoles. A web server is built-in and it includes a dimmable LED desk lamp. It can access up to 202 playbacks with virtual playback controls and supports up to 64 universes. Shows can be transferred to other MagicQ consoles over a network or USB stick.

ITEM	DESCRIPTION	PRICE
MAXI-WING	Complete lighting controller (Mac/Win)	CALL

ChamSys

CHAMSYS MAGIC HD BOX This media player solution is designed for use with a projector, LED wall controller or plasma screen and has full remote control capability, remote configuration and status monitoring. Runs on Linux with solid state drives and can be controlled via DMX512, ArtNet or ACN Streaming DMX. It can also be directly connected to a ChamSys MagicQ USB Wing or operated in standalone mode.

Features a custom matrix engine with 4 DVI-I outputs, switchable from (2) media player sources and (2) test pattern generators (colors, black), that can be controlled from a lighting console and programmed to switch between sources according to events (e.g., start up or shutdown).

The DVI-I connectors can output DVI or analog VGA. Also features an Ethernet switch that gives 4 separate ports you the ability to connect multiple Magic HD Boxes. Media can be uploaded via USB or over network from Magic Q software.

ITEM	DESCRIPTION	PRICE
MAGICHD-BOX	Media player solution with DMX512, ArtNet, ACN streaming controllability	CALL



CHAMSYS MAGICQ MINI WING Connects to Windows or Mac PC via USB to control lighting, video and LED with MagicQ software. It is the smallest wing in the MagicQ range, designed for playback for shows of up to 64 universes. It has one fully patchable direct DMX output, additional connections can be made via Ethernet, and the unit receives power over USB. Includes 10 playback faders and buttons. Shows can be transferred to other MagicQ consoles over a network or USB stick.

ITEM	DESCRIPTION	PRICE
MINI-WING	Lighting controller for PC (Mac/Win)	CALL



CITY THEATRICAL INC

CITY THEATRICAL SHOW DMX SHOW BABY™ 5

This breakthrough in plug-and-play wireless DMX and RDM transmission, and can be used either as a wireless DMX transmitter or receiver. Simple set-up with instant plug-and-play configuration. For a transmitter plug a DMX cable in the SHoW Baby reads no cable it configures to a receiver. All you need now to set up a SHoW DMX SHoW Baby units and two minutes! It also features DMX Neo® 2.4GHz Frequency Hopping Spread Spectrum Radio and has 5-pin XLR connectors for DMX in/out. Includes pipe mount bracket for easy C-Clamp hanging.

ITEM	DESCRIPTION	PRICE
SHOW-BABY-5	Wireless DMX Transceiver	297.50



CITY THEATRICAL INC

CITY THEATRICAL SHOW DMX D2 & D4 DIMMERS The tiny yet powerful SHoW DMX D2 and D4 Dimmers provide an affordable way to control LED tape, other LEDs, or low voltage incandescent fixtures. Available in a 2- or 4-channel version, with either wired DMX input or integrated SHoW DMX Neo® Wireless DMX Receiver.

ITEM	DESCRIPTION	PRICE
5720	SHoW DMX D2 Dimmer, wired input	212.50
5722	SHoW DMX Neo D2 Dimmer	365.50
5740	SHoW DMX D4 Dimmer, wired input	391.00
5742	SHoW DMX Neo D4 Dimmer	501.50



DOUG FLEENOR DESIGN

PRODUCTS FOR DMX512

DOUG FLEENOR DESIGN PRESET 10 ARCHITECTURAL DMX512 CONTROL DEVICES

The PRE10-A can take up to 10 snapshots from a DMX console for playback. Fade times can be set from 0-999 seconds and this device offers "Radio Button" operation, where only one preset can be active at one time. The PRE10-A-POPO has 10 HTP presets that can be turned on or off individually. The PRE10-A2 expands on the PRE10-A by featuring a grand master, pile-on mode (input + preset), jumper selectable button modes (radio or push on/off), and face panel lockout. The PRE10-A2's separate input and output ports allow you to merge incoming levels with the local preset. You can share control between a live console and multiple PRE10-A2s, as well as control multiple rooms with one controller.



ITEM	DESCRIPTION	PRICE
PRE10-A10-zone DMX512 wall controller	487.62
PRE10-A-POPO10 HTP preset DMX512 wall controller	487.62
PRE10-A210-zone DMX512 wall controller with grand master, pile-on mode	908.82



ELATION EMULATION LIGHTING CONTROL SOFTWARE

Used for DMX 512 lighting control for intelligent lights, LED, dimmers, lasers and various other effects. The software is shipped with a USB-to-DMX adapter cable, compliant with the new DMX512-A standard. The key to the design of Emulation Lighting Control Software is its intuitive graphical user-interface. It is specifically designed to reduce the amount of time required to learn how to operate the software. Combined with its affordable price, this software package is available to a large audience of lighting users who want easy-to-use, yet powerful lighting control software. Available for Mac OS X and Microsoft Windows.



ITEM	DESCRIPTION	PRICE
EMULATIONLighting control software	499.99

ELATION ART-1024 TOUCH-SENSITIVE LIGHTING CONTROLLER

A DMX lighting controller with user interface featuring 14 buttons, 1 fader, and 28 LEDs. It is touch-sensitive and wall-mountable. There is a slot for a mini SD card for standalone memory use or you can program it with the included PC software. The unit also features a real time clock and calendar, an IR receiver, RS232 communication, (2) DMX outputs, USB and Ethernet connections.



ITEM	DESCRIPTION	PRICE
ART-1024Wall-mount DMX controller	899.99

ELATION LIGHTING NANO HOG 4 LIGHTING CONSOLE

For use with Hog 4 PC software (included), the Nano Hog 4 allows you to turn your computer into an intuitive lighting console. The Nano Hog 4 connects via USB and features the same front panel as the Road Hog 4. Features (2) slots for optional MIDI/LTC or Super Widgets (sold separately), an LED desklight, (4) encoders, (12) user keys, (10) playback faders, dimmable feedback LEDs, status LEDs, (2) USB sockets and a dust cover.



ITEM	DESCRIPTION	PRICE
NANO-HOG-4PC-compatible lighting console	CALL



ELATION LIGHTING HEDGE HOG 4 DMX LIGHTING CONSOLE

This console runs on the robust Hog 4 operating system and is well suited for use in medium-sized applications such as nightclubs, corporate events, school theatres, houses of worship or as a rental console. Featuring a 12" wide touchscreen, (10) playback faders, (12) user keys, (4) encoders, (2) fixed universes of DMX 512, and up to (4) universes of DMX 512 over Artnet or sACN. Also features a solid state hard disk drive, two USB ports, a Fixture-net Ethernet connector, a desklight, and a dust cover. Connectivity options include MIDI in and out, MIDI Show Control, and MIDI Time Code via an optional (sold separately) external widget.



ITEM	DESCRIPTION	PRICE
HEDGE-HOG-4DMX lighting console	7000.00

ENODE 4



ENODE 8



ELATION LIGHTING ENODE4 AND ENODE8 PRO ETHERNET NODES

Compatible with Artnet and SACN protocols, the eNode4 and eNode8 Pro serve four and eight DMX512 outlets, respectively. Those outlets conform to DMX512-A and can be used as inputs or outputs. The two Ethernet links are 10/100BaseTX connections and the converter can be used as an Ethernet repeater. Features include DMX routing and universe setting, DMX output frame rate setting, protocol selection per port, Ethernet/DMX conversion, Ethernet and DMX merging and backup, DMX splitting and boosting, as well as DMX triggering/remote selection of the control source. Also features a built-in DMX soft patch.

ITEM	DESCRIPTION	PRICE
ENODE-4Ethernet node with (4) DMX512 outlets	499.99
ENODE-8-PROEthernet node with (8) DMX512 outlets	699.99



ENTTEC DMX USB PRO MK 2

The Pro2 supports 2 full universes of DMX512 and can be used as an output to control lights or as a DMX data input from another source to interact with programs on your PC. The device's onboard processor ensures that timing and signaling data is error-free. Isolation protects your computer from unwanted voltage spikes up to 1500V. Standalone Operation mode allows you to run 1 DMX universe lightshow without a PC. Includes driver CD, USB and DMX breakout cables.



ITEM	DESCRIPTION	PRICE
70314USB DMX adapter	209.00

ENTTEC ODE OPEN DMX ETHERNET

This is a single-port DMX to Ethernet node that can be configured as either an input or output via Ethernet with a software utility. It is compatible with EDP and Art-Net DMX over Ethernet protocols. It has 1 DMX input/output connector and an RJ45 Ethernet connection. The POE version has Power Over Ethernet for single RJ45 cable connection.



ITEM	DESCRIPTION	PRICE
70305ODE DMX unit	261.00
70306ODE unit with POE (Power over Ethernet)	314.00

- AUDIO
- MUSIC
- COMPUTER AV
- VIDEO
- LIGHTS
- ACCESSORIES



Follow Us!

Let us show you exactly what to expect with our lighting design computer modeling and pre-visualization.



ENTTEC DMXIS LIGHTING CONTROL PACKAGE

Create exciting live shows with a Mac or Windows-based computer with DMXIS. It is designed for performers who want to run an automated light show while performing on stage. It includes a hardware interface with full microprocessor control and the software program. The system can control any DMX-512 compatible light fixtures. The hardware has (4) LED indicators, interacts with MIDI notes and has 5-pin and 3-pin outputs for flexibility.

ITEM	DESCRIPTION	PRICE
70570	Lighting control software	276.00



ETC/ELEC THEATER CONTROLS NOMAD™ + NOMAD PUCK™

The Nomad USB dongle lets you use your computer as a stand-alone lighting controller for programming and show playback, or as a backup to your Eos or Cobalt family consoles (up to the capacity of the dongle). Nomad dongles also allow your computer to connect to existing Eos/Cobalt consoles as a client, offering another programming location, or the ability to monitor your system right on your PC. Used as a client, Nomad accesses the full output count of the Eos or Cobalt system it's connected to. The Nomad 256 replaces the Eos and Cobalt Client Software kits. A Nomad dongle can be upgraded by purchasing an upgrade code. It communicates over ArtNet and NET3/ACN/ACN Ethernet-based lighting protocols, or by the ETC Gadget™ USB-to-DMX converter, with RDM support available via Net3 Gateways. It works with ETC Universal Fader Wings on PCs, OSC controllers, and supports connection with third-party USB-MIDI panels via Direct MIDI. The Nomad Puck™ is a full-featured mini-computer with an embedded Nomad dongle that provides all the functionality of Nomad, but in a small, self-contained package. It's "locked down", meaning no software other than ETC applications can be installed on it. Use as a stand-alone lighting controller for programming and show playback, or as a backup to your Eos/Cobalt consoles (up to the capacity of the dongle). These systems are available with 256 (upgradeable), 1024, 1536 or 2048 outputs for stand-alone or backup operation. The entry-level Nomad 256 or Nomad Puck 256 makes the perfect remote video interface for your tech table. Nomad works with Windows 7/8, and Macintosh OS X Maverick.



ITEM	DESCRIPTION	PRICE
NOMAD2048	USB Dongle Lighting Controller with 2048 Outputs	3240.00
NOMAD1536	As above, with 1536 Outputs	2520.00
NOMAD1024	As above, with 1024 Outputs	1800.00
NOMAD-256	As above, with 256 Outputs	504.00
NOMAD-PUCK-2048	2048-Output Nomad Mini Computer	CALL
NOMAD-PUCK-1536	1536-Output Nomad Mini Computer	4200.00
NOMAD-PUCK-1024	1024-Output Nomad Mini Computer	3300.00
NOMAD-PUCK-256	256-Output Nomad Mini Computer	1950.00
GADGET	USB DMX Output Interface	337.50
NOMAD-512-UP	Nomad 512 Output Upgrade	972.00

ETC SOURCE FOUR, ES750 DIMMERS

Both versions feature ETC's ES (Electronic Silent) Technology and employ a convection-cooled design. They accept DMX control signals directly, allowing the fixtures to work alongside LEDs and moving lights and allowing system designs to focus on switched power and data distribution, rather than centralized dimming systems.



ITEM	DESCRIPTION	PRICE
ES750	750W electronic silent dimmer	378.00
ES750-A	ES750 with Edison connector	391.44
ES750-B	ES750 with stage pin connector	391.44
ES750-C	ES750 with Twist-Lock connector	405.72
S4DIM	Retrofit kit with burner assembly for Source Four	378.00
S4JR-DIM	As above, for Source Four Jr., Jr. Zoom	378.00
S4PAR-DIM	As above, for Source Four PAR, PARnel	378.00



ETC ELEMENT LIGHTING CONSOLE Based on ETC's Eos® control system with a simplified feature set, Element was designed expressly for modest rigs and maximum hands-on control. Affordable and easy to use, Element packs the fundamentals of lighting control into a compact unit. Element comes in two hardware versions (based on fader count) to suit your needs. Each supports either 250 or 500 channels with two full universes of DMX output. Channel Faders are true Latest Takes Precedence,



so you can use them for simple shows directly or to build up looks for use as submasters, cues, or edit levels stored in subs or cues live. Turn a switch and your channel faders become 40 Submasters for simple playback of live shows. Need subs all the time? The Element 60 provides 20 dedicated submaster faders in addition to the 40 switchable channel/submaster faders. Record cues and fade times into Element's cue list for simple playback of more complex shows using a GO button. At the press of a button, the On Demand ML Controls appear on screen with tools designed to control smaller numbers of non-intensity equipment like scrollers, gobo rotators and mirror heads. Color and Gel Picker tools let you apply just the right color to LEDs and color-mixing accessories and fixtures. Intensity, Focus, Color and Beam Palettes let you store commonly-used settings to buttons you can label yourself. Supports two external DVI monitors (which can be touchscreens).

ITEM	DESCRIPTION	PRICE
LMNT-40-250	40-fader, 250-channel, Element console	4140.00
LMNT-40-500	40-fader, 500-channel, Element console	4500.00
LMNT-60-250	60-fader, 250-channel, Element console	CALL
LMNT-60-500	60-fader, 500-channel, Element console	CALL



ETC ION-1000 LIGHTING CONSOLE Offers Eos® power with integrated control of conventional, LED, and moving lights, as well as media servers. Features 1,024 outputs, upgradeable in 512 output increments to 6,144 outputs, and supports 16,000 channels. Supports (1) or (2) external DVI Windows 7-compatible high-resolution touchscreen or multi-touchscreens, and can be networked to as many as (4) discrete users on multiple control surfaces. Hosts up to (6) Universal fader wings, giving a total of 300 additional cue lists or mapped submasters with paging controls, for even more hands-on, tactile control. Use as standalone system or as a remote programming station for Gio® or Eos Ti™ systems. Full output of host system is supported when used as a client in Gio and Eos-family systems. Supports interactivity with Nomad™, Nomad Puck™ and Net3™ systems, and Net3 Radio Focus Remote apps give remote control via mobile devices.

ITEM	DESCRIPTION	PRICE
ION-1000	1,024-output compact lighting control console	6630.00
FADW-1X20	Universal fader wing, 1x20 faders	939.60
FADW-2X10	As above, 2x10 faders	1020.60
FADW-2X20	As above, 2x20 faders	1887.60



ETC SMARTFADE® ML SmartFade ML provides palettes, parameter "fan" and built-in dynamic effects with an easy-to-learn direct-access style of operation. Has a capacity for up to 24 moving lights, an additional 48 intensity channels (dimmers), and the ability to patch to 2 complete universes of DMX512 (1,024 outputs). The keys and built-in LCD displays also provide status feedback without the need for an external monitor.

ITEM	DESCRIPTION	PRICE
SFML	Moving light controller	2336.10

AUDIO



MUSIC



COMPUTER AV



VIDEO



LIGHTS



ACCESSORIES



AUDIO



SF1248

ETC SMARTFADE1248 AND 2496

- 48 or 96 channels in normal mode
- 12 or 24 channels in two-scene mode
- DMX input (full universe each)
- USB for software updates
- 24-step sequences (48 available)
- 99-step STACK, playback via crossfaders
- Manual, timed and rate-override playback
- LCD menu for configuration and preview

ITEM	PRICE
SF1248.....	1210.95
SF2496.....	1478.10

ETC SL1210TPW SMART PACK® WALL MOUNT WITH THRUPOWER



This compact, reliable, and affordable wall mount dimmer features easy-to-install connections and offers 12 dimmer units, with control over a variety of loads. It has (3) modes: 'dim'—for quality fades, 'hot'—to prevent accidental shut off of any equipment requiring constant power during performance, and 'relay'—utilizing a patched DMX address to allow the circuit to control the air-gap relay while bypassing dimming and electronics. It includes (32) built-in presets and sequencer with programmable fade/hold times for stand-alone operation, fully-rated hydraulic magnetic circuit breakers, is DMX512A and RDM compatible, and SmartLink® enabled.



ITEM	DESCRIPTION	PRICE
SL1210TPW.....	12 x 10A SmartPack Wall Mount with ThruPower.....	2250.00

ETC SMARTPACK CE

PORTABLE PACKS These portable dimmers pack professional quality dimming into a rugged 19-inch 2RU rackmount unit. Available with either (6) 15A dimmers or (12) 10A dimmers. SmartPack has 32 built-in presets and a sequencer for stand-alone operation. Features true thyristor reliability based on Sensor™ technology and include all magnetic circuit breakers. DMX512A compatible.



ITEM	DESCRIPTION	PRICE
SL620 Series: 6 20A dimmers		
SL620A.....	Edison connectors.....	1404.00
SL620B.....	Stage pin connectors.....	1404.00
SL620C.....	GTL connectors.....	1326.00
SL620P.....	Powercon connectors.....	1326.00
SL620V.....	1 multi-pin connector.....	1521.00
SL620TM.....	Terminal strip.....	1521.00
SL1210 Series: 12 10A dimmers		
SL1210A.....	Edison connectors.....	1599.00
SL1210B.....	Stage pin connectors.....	1599.00
SL1210P.....	GTL connectors.....	1599.00
SL1210V.....	2 multi-pin connectors.....	1794.00
SL1210TM.....	Terminal strip.....	1794.00

ETC SMARTBAR 2 SmartBar 2 gives you next-generation dimming for portable or permanent installations without busting budgets. It provides an integrated dimming and fixture-mounting solution for compact, low-power applications such as rentals, industrials, or even small touring productions. Available in 2-, 4- or 6-dimmer versions, with each dimmer capable of providing up to 1200 Watts. Each SmartBar 2 is supplied with a 12' SO power cord with bare ends (no connector). Supplied with c-clamp and color frame.



ITEM	DESCRIPTION	PRICE
SB2-10-A.....	2-circuit SmartBar 2, 1-phase, Edison.....	684.45
SB2-10-B.....	2-circuit SmartBar 2, 1-phase, stage pin.....	684.45
SB2-10-C.....	2-circuit SmartBar 2, 1-phase, Twist-Lock.....	684.45
SB4-10-A.....	4-circuit SmartBar 2, 1-phase, Edison.....	765.45
SB4-10-B.....	4-circuit SmartBar 2, 1-phase, stage pin.....	765.45
SB4-10-C.....	4-circuit SmartBar 2, 1-phase, Twist-Lock.....	765.45
SB4-10X-A.....	4-circuit SmartBar 2, 2-phase, Edison.....	846.45
SB4-10X-B.....	4-circuit SmartBar 2, 2-phase, stage pin.....	846.45
SB4-10X-C.....	4-circuit SmartBar 2, 2-phase, Twist-Lock.....	846.45
SB6-10X-A.....	6-circuit SmartBar 2, 2-phase, Edison.....	1322.10
SB6-10X-B.....	6-circuit SmartBar 2, 2-phase, stage pin.....	1322.10
SB6-10X-C.....	6-circuit SmartBar 2, 2-phase, Twist-Lock.....	1322.10
SB6-10Y-A.....	6-circuit SmartBar 2, 3-phase, Edison.....	1244.10
SB6-10Y-B.....	6-circuit SmartBar 2, 3-phase, stage pin.....	1244.10
SB6-10Y-C.....	6-circuit SmartBar 2, 3-phase, Twist-Lock.....	1244.10



SS-IR33



SS-305



SS-305 BLACK

INTERACTIVE TECHNOLOGIES SCENESTATION 3 This single-gang in-wall lighting control unit can control almost any DMX device and is ideal for restaurants, residential, and trade show applications where its simplicity of use will be of great value to you. The SceneStation 3 can run simple presets or can run shows that have up to 64 steps, as well as execute advanced functions such as running chases, sequential scenes, momentary functions, toggle, and more.

The wireless StationLink option is available on select SceneStation 3 models and allows you to link multiple units together. The SceneStation 3 can be programmed by the SceneStation Studio software (downloadable through Interactive Technologies' website), which can also manage and control the wireless-capable units.

The units can also be programmed by the Programmer's IR Remote. The SceneStation 3 is also available as a "portable" unit that is great for rental houses. Contact your sales representative for information on accessories not listed below that you might need to complete your SceneStation setup.

For more information on about SceneStation 3, and the variety of available peripherals, please contact your Sales Pro.



INTERACTIVE TECHNOLOGIES CUESERVER LIGHTING/AUTOMATION CONTROL DEVICES These Ethernet-based devices fit a wide range of applications (show control, playback control, architectural lighting processor) can be integrated into a variety of systems (Crestron, AMX, etc.), and can serve as the center for a larger control system that includes many compatible button stations, touchscreens, etc. Features include a DMX playback engine, CueScript scripting language, a real-time clock/calendar, SMPTE/MTC time code synchronization, various I/O ports and operation via the web (iPhone and iPad capable, as well).

For more information on about CueServer, and the variety of available peripherals, please contact your Sales Pro.

ITEM	DESCRIPTION	PRICE
CS-800.....	CueServer Pro w/LCD display and MIDI ports.....	1683.06
CS-810.....	CueServer Mini w/o Pro version's features.....	1215.28
CS-816.....	CueServer Express portable solution for iPhone and iPad.....	560.40



INTERACTIVE TECHNOLOGIES CUESTATION BUTTON STATIONS

Available in a variety of configurations and styles, these wall-mount button stations are for use with Interactive Technologies' CueServer and allow you to control automated audio, lighting, and show playback, as well as other similar actions. Can also be used for applications other than those involving CueServer.



Please contact your Sales Pro today to discuss available CueStation options and integration.



Follow Us!

Let us show you exactly what to expect with our lighting design computer modeling and pre-visualization.



JANDS VISTA LIGHTING CONTROLS

Design lightshows visually, without the need for converting a complex series of numbers or spending hours punching in sequences. This console's user interface features a "timeline" that gives a complete picture of your lightshow, with total control over lighting events. The Vista's approach to the lighting control user interface makes it easy to use and its generic fixture model makes changing fixtures easy. Features include console switching in the event of main console failure, integrated media server control, matrix and video effects, default and split fade times and dual-boot function for those wanting to work with v1 and v2 on the same console. Available as a full-featured console or as a software option with a variety of control surfaces and channel counts.



ITEM	DESCRIPTION	PRICE
JAVISTAL5	Console with 30 playback	CALL
JAVISTAS3	Control surface with 20 playbacks (ch. ct. determined by dongle)	CALL
JAVISTAS1	Control surface with 5 playbacks (ch. ct. determined by dongle)	4363.45
JAVISTAS1/1024	Compact control surface with 5 playbacks and 1024 chnl dongle	CALL
JAVISTAC128	128-control channel dongle	318.50
JAVISTAC256	256-control channel dongle	704.03
JAVISTAC512	512-control channel dongle	1132.95
JAVISTAC1K	1024-control channel dongle	1815.45
JAVISTAC2K	2048-control channel dongle	2957.50

JANDS STAGE CL

Designed to control the color and intensity of LED fixtures as well as the intensity of conventional fixtures. Each of the 12 channels has separate saturation and hue encoders, with LEDs that display the color you are creating, as well as traditional faders and flash buttons. Additional features include a touch screen, channel grouping, color presets, full and half saturation settings, one-touch sequence recording, manual playback speed and chase rate adjustment, USB ports, DMX512 and Ethernet outs, and more.



ITEM	DESCRIPTION	PRICE
JASTAGECL	LED Fixture Controller	1360.45



LIGHTRONICS TL-2448 LIGHTING CONSOLE

- 1200 scenes
- Full go button
- Built-in softpatch
- Wireless DMX Option
- 36 programmable chases
- Cue stack stores up to 600 scenes
- 48 conventional channels / 8 moving light sub master controllers
- LMX-128 and DMX-512 protocols



ITEM	DESCRIPTION	PRICE
TL-2448	Lighting console	1800.00
TL-2448-WS-TX	Lighting console with Wireless DMX	2212.50



LEVITON D4-DMX PROGRAMMABLE DIMMER PACK

Leviton combines cutting edge Leviton technology and performance with both DMX and Microplex control in the D4-DMX Dimmer Pack. It boasts convenient features such as resettable circuit breakers in lieu of fuses and 1-button setup of digital DMX addressing via a user-friendly LED panel, eliminating dip-switch settings. Its sturdy metal chassis makes this rugged pack ideal for both stationary and portable applications. In addition to multichannel DMX and Microplex dimming control, these units can also provide a stand-alone chaser function with 16 pre-programmed patterns. Data input and output are provided for daisy-chaining of devices. Input is 120V, 60Hz on 15A Edison plug. Output is 120V, 60Hz, 1200W per channel, 2400W maximum.



ITEM	DESCRIPTION	PRICE
D4-DMX-3	4-channel dimmer with 3-pin DMX	217.35
D4-DMX-5	4-channel dimmer with 5-pin DMX	217.35



LEVITON 3000 SERIES CONTROLLERS

An economical choice in lighting control when a basic feature set is required. Offers either 4 or 8 channels of control, scene memory, and several chase options (2 selectable chases, channel chase, scene chase, speed control, direction control, and audio output.) These features provide easy lighting effects at the touch of a button. Connector pin outs are permanently screened next to the connector.

ITEM	DESCRIPTION	PRICE
N3004-00D	4-channel DMX controller	201.25
N3008-00D	8-channel DMX controller	262.50

LEVITON N7000/7500 SERIES

The N7000 Series lighting consoles are simple and flexible with three operating modes. The consoles provide standard 2-scene preset operation, wide mode, single scene operation for double the channel capacity, and memory scene operation. The N7000 Series is particularly well-suited to small theaters and stage performances. These products are so easy to program and operate, the instructions are printed right on the consoles. Features include individual channel bump buttons, dual dipless crossfaders, user programmable chase and scene memories, and grand master/blackout functions. The 7000 Series has XLR Microplex interface standard with optional DMX512. The 7500 Series has DMX512 standard, soft patching, auto faders, non-volatile memory, audio sync, cue stacking, and MIDI.



ITEM	DESCRIPTION	PRICE
N7008-000	8/16-channel, 8-scene memory	447.93
N7016-000	16/32-channel, 16-scene memory	665.28
N7516-000	16/32-channel, 256 scenes	1832.36
N7024-000	24/48-channel, 24-scene memory	877.91
N7524-000	24/48-channel, 384 scenes	2172.56
N7532-000	32/64-channel, 512 scenes	2692.31
A7512-001	DMX512 adapter for N7008/7016/7024	107.73

LEVITON DMX TOUCHSCREEN

Leviton's DMX Touch screen offers a fully flexible user interface. Implementing touchscreen-style controls provides for a multi-page user experience specifically tailored to your application. Includes configuration software, power supply and custom back-box. Features direct DMX output, configuration via Ethernet or USB, controllable backlight timeout, and password protection.



ITEM	DESCRIPTION	PRICE
TS005-DI5	DMX touchscreen	979.29



AUDIO



LEPRECON ULD SERIES DIMMERS Each ULD Series dimmer is equipped with dual 25-amp SSR's and illuminated magnetic breakers, plus over volt/over temp protection. Fully encapsulated chokes come standard to further ensure quiet operation. Through the display-based menu system, each channel can be defined as either a non-dim, fluorescent or fixed intensity level. DMX-512 on 5-pin XLR connectors.



ITEM	DESCRIPTION	PRICE
ULD360-STANDARD Stage pin 6-channel pack with single 15-amp breaker	850.00
ULD360-HP Stage pin 6-channel pk with dual 15-amp breakers	962.00
ULD360-DUPLEX 6-channel pk with single 15-amp breaker and Edison conn	815.00
ULD360-DUPLEX-HP 6-channel pk with dual 15-amp breaker and Edison conn	917.00
ULD340-STANDARD Stage pin 4-channel pk with single 15-amp breaker	783.00
ULD340-HP Stage pin 4-channel pk with dual 15-amp breakers	897.00
ULD340-DUPLEX 4-channel pk with single-amp breaker and Edison conn	751.00
ULD340-DUPLEX-HP 4-channel pk with dual 15-amp breakers and Edison conn	866.00

LEPRECON LP-612/LP-624 CONTROL CONSOLES

Available with 12 or 24 channels, these consoles incorporate full travel faders and a rugged aluminum chassis. Features 2-scene preset mode, soft patch, chase memory, bump with Add and Solo modes, and a cue stack offering 50 programmable cues with crossfader and "Go" button control. Output via 3-pin Microplex with DMX-512 and analog also available. All three protocols are accessible simultaneously.



ITEM	DESCRIPTION	PRICE
LP612MPX-DMX 12-channel multiplex/digital/analog	983.00
LP624MPX-DMX 24-channel multiplex/digital/analog	1676.00



LEPRECON ARCHITECTURAL PRESET CONTROL SYSTEM

Allows you to integrate architectural and theatrical lighting control into one DMX-based system. The DMX power supply provides DC power for up to 10 APC wall panels, DMX in/out, and connections to the wall panels. Additional power supply features include isolation and buffering from the console and wall panels, DMX signal re-timing, and the ability to strip alternate start codes from the data stream prior to sending it to the system. Additional system features include 12 programmable scenes for 512 channels, programmable fade time on presets, and programmable blackout fade time. Wall panels use Cat 5/Cat 6 cable and RJ45 connectors.

ITEM	DESCRIPTION	PRICE
90-03-6150 DMX power supply, DMX in/out	725.00
90-03-6151 Wall panel, 1-button preset with off, DMX in/out, RJ45	366.00
90-03-6152 Wall panel, 3-button preset with off, DMX in/out, RJ45	379.00
90-03-6153 Wall panel, 6-button preset with off, DMX in/out, RJ45	460.00
90-03-6154 Wall panel, 12-button preset with off, DMX in/out, RJ45	570.00
90-03-6155 APC wall mount bracket kit for power supply	50.00
90-03-6156 APC rackmount bracket kit for power supply	46.00

LEPRECON WATSON POWER MANAGEMENT

Provides AC power switching, and DMX buffering, for groups of LED fixtures, color scrollers, or other lighting accessories. Via 1 DMX control channel or through sensing DMX data, fixtures can be turned off when not in use. An additional output adds DMX capacity, as well as a firewall between fixtures and the rest of the control system. Additional features include easy reset control for fixtures needing power cycling and full sine wave power. Power lead not included.



ITEM	DESCRIPTION	PRICE
90-40-0001 9" enclosure, 15A, 1 Powercon in, 1 duplex out, 1 DMX in, 2 DMX out	602.00
90-40-0002 9" enclosure, 15A, 1 Powercon in, 1 Powercon out, 1 DMX in, 2 DMX out	602.00
90-40-0004 19" enclosure, 15A, 1 Powercon in, 6 duplex out, 1 DMX in, 2 DMX out	761.00
90-40-0006 72" raceway, 15A, 1 Powercon in, 6 duplex out, 1 DMX in, 2 DMX out	988.00
DPA-A Edison to Powercon lead	67.50
DPA-B Stage Pin to Powercon lead	67.50
DPA-C Twist-Lock to Powercon lead	67.50



MARTIN M2GO AND M2PC COMPACT LIGHTING CONTROL SOLUTIONS

The M2GO is a fully standalone lighting console while the M2PC is a complementary control surface to Martin's M-PC controller software which will connect to your Windows PC via USB 2.0. Both options feature 4 encoders for parameter control, customizable function keys and a 3.5" integrated touchscreen. Both versions are licensed for 4 DMX universes of output; the M2GO has 4 physical DMX output connectors while the M2PC has 2 as standard. Both versions can also output both Artnet and Maxnet protocols.



ITEM	DESCRIPTION	PRICE
M2GO Compact lighting consoleCALL
M2PC Compact control wing3807.70

MARTIN M1 LIGHTING DESK

The M1's dual-core processor ensures a fast and responsive interface. Includes a hi-res 16:9 touchscreen that can be adjusted to provide the best viewing angle. An additional monitor can be connected via VGA or DVI. Fixture parameters can be controlled using the M1's four encoders, its touchscreen, by trackball, or via the keypad. The Playback section has 10 fader playbacks, the Submaster section features 12 faders with flash buttons, as well as an additional 12 flash buttons. Remote controllable via iPhone app (not included) or Maxxyz Manager. Fixtures can be added to patches and grouped easily. Effects generation gives each parameter its own effect parameter. Multiple effects can be synched together. Provides multiple preset groups that allow for customization of all parameter assignments. Thousands of cue lists, triggerable via SMPTE and MIDI timecode, can be created and stored, each with up to 10,000 cues - each list can be set as chase, override, timecode, submaster, or inhibitive. User settings can be saved to USB stick. External DMX values can be merged into the M1's outputs for external cue list control and can be captured for programming as cues. RDM compatible. (4) DMX 5-pin XLR, (2) XLR desk lamp connectors and 3-pin IEC AC power (cable included).



ITEM	DESCRIPTION	PRICE
M1-TS Console/controllerCALL
ETHER2DMX8-BOX DMX router/merger/splitter2639.00

MARTIN LIGHTJOCKEY LIGHTING CONTROL

LightJockey 2.7 is a flexible, easy to use Windows-based controller that is supplied with a USB-DMX Interface. It includes all the features for lighting professionals in clubs, mobile DJ, touring and special events markets: large fixture library, user-friendly graphic functionality, and advanced shape generator for fast, automated movement programming. For flexible music capabilities, LightJockey interfaces with Winamp™ to play a multitude of digital audio files including MP3s and CD-ROM. It also supports SMPTE and MIDI timecode with suitable interface. Also includes a One-Key USB dongle that stores multiple licenses and protects software.



ITEM	DESCRIPTION	PRICE
LIGHTJOCKEY-II-KIT PC lighting controller1108.38



Follow Us!

Let us show you exactly what to expect with our lighting design computer modeling and pre-visualization.

WE'VE GOT YOU COVERED!

From theatres, schools, and houses of worship, to live event productions Leprecon is the answer to all your lighting control, dimming, and power distribution needs.

LPC-48V Console ▶▶▶

Leprecon Version III LPC-48V with encoders is an affordable lighting console designed for small to medium lighting systems. Using a VGA monitor or touchscreen, the console easily controls LED fixtures, Moving Light fixtures, and conventional dimmers using faders. Use the LPC console's six "Quick Looks" for bringing up work lights or setting a look with the push of a button.

Features:

- Hands on Fader Control for Fast Easy Operation
- Three Front Panel Encoders for Setting Fixture Parameters
- One Powerful, Easy to Use - User Interface for all Consoles
- Designed and Built in the USA
- Easy Learning Curve makes it Perfect for Volunteers, Students & Professionals



APC Architectural Preset Control ▶▶▶

The Leprecon APC Series is designed to provide a solution for integrating architectural and theatrical lighting control into a single DMX-based system. With a clean, low profile design that blends into any environment, APC components are easy to install, wire and configure.

Features:

- Direct DMX Output
- Up to 12 Programmable Scenes of 512 Channels
- Panels can be Disabled when Console is in Use
- Simple Interconnect using CAT5 Cabling
- Programmable Fade Time for Each Preset
- Single Programmable Blackout Fade Time



800-356-5844
fullcompass.com

Leprecon[®]
Lighting for Professionals

AUDIO



ETC SOURCE FOUR® LED Combine the size, look, and optics of the Source Four family with the user-interface and high efficiency of the Selador Desire™ line of LED luminaires. With no burnt gels or lamps to replace, Source Four LEDs have the highest lumens per watt of any LED spotlight while yielding a 50,000-hour life. Use the same shutter barrel, accessories, and lenses as existing Source Four fixtures (Enhanced Definition lens tubes suggested). Feature 60 Luxeon® Rebel LED emitters and come in daylight, tungsten and Lustr+ configurations. x7 color system offers brighter light and larger spectrum of colors. Series 2 Lustr adds lime-green for better conventional Source Four fixture color matching thru increased lumen output, along with more red LED emitters giving stronger ambers, straws and pinks. Available with the LED light engine only or the light engine w/shutter assembly.



ITEM	DESCRIPTION	PRICE
S4LEDDS-0-X	Daylight 5600K LED fixture, body and shutter assembly, black	1995.00
S4LEDD-0-X	Daylight 5600K LED fixture, body only, black	1950.00
S4LEDTS-0-X	Tungsten 3000K LED fixture, body and shutter assembly, black	1995.00
S4LEDT-0-X	Tungsten 3000K LED fixture, body only, black	1950.00
S4LEDLS-0-X	Lustr+ x7 color system LED fixture, body and shutter assembly, black	1995.00
S4LEDL-0-X	Lustr+ x7 color system LED fixture, body only, black	1950.00
S4LEDS2LS-0-X	Series 2 Lustr color system LED fixture, body and shutter assembly, black	2395.00
S4LEDS2L-0-X	Series 2 Lustr color system LED fixture, body only, black	2395.00
S4LED-SFD	Soft focus filter	15.00
419EDLT	Enhanced Definition lens tube, 19 degree	215.60
426EDLT	Enhanced Definition lens tube, 26 degree	215.60
436EDLT	Enhanced Definition lens tube, 36 degree	215.60
LED50LT	S4LED Specific 50 degree Lens Tube	254.10
S4LED-SWD6	Smooth-wash diffuser for 6.25 gel frame	27.00
S4LED-SWD7	Smooth-wash diffuser for 7.5 gel frame	28.00
S4LED-SWD12	Smooth-wash diffuser for 10° lens tube	60.00
S4LED-SWD14	Smooth-wash diffuser for 5° lens tube	95.00



ETC DESIRE™ LED LIGHT FIXTURES The Desire D40 contains 40 Luxeon® Rebel LED emitters comprised of 7 different colors and features a user interface on the rear. It can also be controlled using any RDM-enabled controller. Offers 5 different DMXs: Calibrated RGB, Calibrated HSI, Calibrated HSiC, Direct, and Studio. D40XT fixtures share the 40 Series' features but adds waterproof and weatherproof housings.

ITEM	DESCRIPTION	PRICE
SELD40DI-0A-X	D40 Studio Daylight fixture with 5600K LEDs for cool white output	1634.10
SELD40FI-0A-X	D40 Fire x7 color fixture with extra-high red brightness	1400.10
SELD40HI-0A-X	D40 Studio HD fixture with warm and cool white LEDs, 5 additional LED colors	1478.10
SELD40II-0A-X	D40 Ice x7 color fixture with extra-high blue brightness	1400.10
SELD40LI-0A-X	D40 Lustr+ x7 color fixture with high-intensity white LEDs	1400.10
SELD40TI-0A-X	D40 Studio Tungsten fixture with 3000K LEDs for warm white output	1634.10
SELD40VI-0A-X	D40 Vivid high-intensity, high-saturation x7 color fixture	1400.10
SELD40FO-0X	D40XT Fire x7 color fixture with extra-high red brightness	1599.00
SELD40HO-0X	D40XT Studio HD fixture with warm and cool white LEDs, 5 additional LED colors	1677.00
SELD40IO-0X	D40XT Ice x7 color fixture with extra-high blue brightness	1599.00
SELD40LO-0X	D40XT Lustr+ x7 color fixture with high-intensity white LEDs	1599.00
SELD40TO-0X	D40XT Studio Tungsten fixture with 3000K LEDs for warm white output	1833.00
SELD40VO-0X	D40XT Vivid high-intensity, high-saturation x7 color fixture	1599.00
SELD40FI-0A-X	D60 Fire x7 color fixture with extra-high red brightness	1400.10



ETC SOURCE FOUR LED CYC LENS ADAPTER

- Highly tuned optics
- 2:1 luminaire spacing
- Smooth, homogenized distribution
- Works with any Source Four LED array
- Lights subtly-painted drops with x7 color
- Rugged die-cast aluminum construction
- Heat- and impact-resistant polycarbonate lenses
- Works within the footprint of traditional incandescent cyc lights



ITEM	DESCRIPTION	PRICE
S4LEDCYC	CYC lens adapter for S4 fixture	331.80

PHILIPS



PHILIPS COLOR KINETICS COLORBLAST TRX THEATRICAL WASH LIGHT

- Interchangeable lenses
- Stand alone or DMX operation
- Red, Green, Blue, Amber, and White LEDs
- 4 DMX modes including 16-bit color control
- Wide variety of optional beam shaping accessories



ITEM	DESCRIPTION	PRICE
116-000029-00	Color Blast TRX	779.00
120-000005-04	Top hat	43.00
120-000009-04	Half top hat	39.00
120-000015-04	Egg crate louvers	101.00
120-000019-04	Barndoors	105.00
120-000025-00	Horizontal spread lens 36°/50°	62.00
120-000025-01	Horizontal/vertical spread lens 40°/40°	54.00

NEW!

PHILIPS COLOR KINETICS ICOLOR FLEX MX GEN2

- Standard 50-node strands can be field-shortened
- Custom lengths of 5 to 60 nodes are also available
- Flexible strands of 50, individually addressable, full-color LED nodes
- Strands can be mounted directly to a surface like traditional string lights
- Fully sealed for maximum fixture life and IP66-rated for outdoor applications
- Each node produces full-color, daylight-visible light output of up to 2.3 candela
- High light output affords superior long-distance viewing for architectural accent and perimeter lighting, large-scale signage and building-covering video displays



ITEM	DESCRIPTION	PRICE
101-000076-04	4" on-center node with Clear Dome Lens, in white	488.00
101-000076-06	As above, in black	488.00
101-000076-00	4" on-center node with Translucent Dome Lens, in white	488.00
101-000076-02	As above, in black	488.00
101-000076-05	12" on-center node with Clear Dome Lens, in white	488.00
101-000076-07	As above, in black	488.00

PHILIPS COLOR KINETICS COLORBLAZE TR4 LED BATTEN

- RGBW or RGBA enhanced color mixing fixtures
- Intensely saturated full-color light output
- Tailor light output to specific applications
- Individually addressable 6" segments accommodate fine control
- Adjustable dimming curves and transition speeds
- Delivers approximately 2000 lumens of color-changing light per foot
- Control options for architectural, entertainment and portable applications

NEW!



ITEM	DESCRIPTION	PRICE
116-000032-01	4' RGBW LED fixture, 10° beam angle	3430.00
116-000030-01	As above, 18° beam angle	3430.00
116-000033-01	6' RGBW LED fixture, 10° beam angle	5000.00
116-000031-01	As above, 18° beam angle	5000.00
116-000032-00	4' RGBA LED fixture, 10° beam angle	3430.00
116-000030-00	As above, 18° beam angle	3430.00
116-000033-00	6' RGBA LED fixture, 10° beam angle	5000.00
116-000031-00	As above, 18° beam angle	5000.00



Follow Us!

Let us show you exactly what to expect with our lighting design computer modeling and pre-visualization.



Liba, National Theatre, London,
lighting design by Neil Austin, photo © Max Nanula

Source Four LED™

Lighting that's believable.

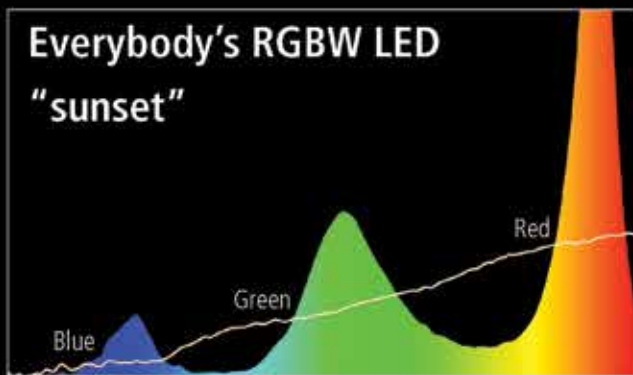

Graph represents R08 spectral distribution.



The new Series 2™
Better color. Now twice as bright.

FULL COMPASS
PRO AUDIO VIDEO LIGHTING
MUSICAL INSTRUMENTS
800-356-5844
fullcompass.com



AUDIO



AMERICAN DJ DOTZ FLOOD RGB WASH/BLINDER FIXTURE

- 6 DMX Modes
- IEC AC In/Out
- Electronic Dimming
- Barn doors adjust 60° beam angle
- Compatible with ADJ UC3 series controllers
- (6) 30W COB (Chip On Board) Tri RGB LEDs
- Wireless control via DF FC foot pedal controller
- Built-in Programs, 3-zone pixel control, 100% Electronic Dimming



ITEM	DESCRIPTION	PRICE
DOTZ-FLOOD	RGB Wash/Blinder fixture	549.99
DF-FC	Foot pedal controller	99.99



AMERICAN DJ DOTZ BAR 1.4 LED WASH BAR WITH BLINDER

- DMX-512 protocol
- 0-100% Electronic Dimming
- Built-in Microphone and preset colors
- 3-, 6-, 8-, 12- & 17-Channel DMX Modes Great for Stage Lighting, Bands or Night Clubs
- 4 Operating Modes – Sound-Activated, Auto Run, Built-In Programs or DMX Control
- 1x4 COB (Chip On Board) TRI LED high-output linear wash bar

ITEM	DESCRIPTION	PRICE
DOTZ-BAR-1.4	Wash/Blinder LED fixture	199.99

AMERICAN DJ ULTRA BAR 6 INDOOR LINEAR LED FIXTURE

- LED pulse & strobe
- 3-Section Pixel control
- 35 built-in Color Macros
- Ultra bright TRI RGB LEDs
- Variable RGB color mixing
- 0-100% Electronic Dimming
- 22.5" (0.5 m) indoor linear bar w/ (6) 3W
- 3-, 5-, 6-, 7-, 8-, 9- or 11-channel DMX modes
- Auto Run, Program Mode, Sound-Activated, RGB Dimmer, Static Color and DMX-512 operational modes
- Includes mounting brackets for wall-mounting or placement on the ground



QUICK ALIGN END LOCKING FEATURE

ITEM	DESCRIPTION	PRICE
ULTRA-BAR-6	Indoor linear LED fixture	149.99

AMERICAN DJ MEGA TRIPAR PROFILE LOW PROFILE LED WASH

- Flicker free
- 40° beam angle
- Power Draw: 16W max
- 7 DMX channel modes
- 0-100% electronic dimming
- Slim par with (5) 3W TRI LEDs (RGB)
- Standalone or master/slave Configuration
- "Sit-flat" design: Power and DMX I/O designed so unit can be set flat on ground or inside truss
- Includes a scissor yoke (hanging bracket) to hang on truss, mount on a wall or set on the ground
- Digital DMX display with 4-button menu for easy navigation
- 5 operational modes: Auto mode and sound active feature with built-in programs

UNIQUE SIT-FLAT DESIGN



ITEM	DESCRIPTION	PRICE
MEGA-TRIPAR-PROFILE	Low profile LED wash light	99.99

NEW!

AMERICAN DJ BATTERY-POWERED WIFLY LED WASH BAR

- Flicker-free
- 120° Beam angle
- 35 built-in Color Macros
- Includes built-in ADJ WiFly Wireless
- 3 DMX Channel Modes and 3 operational modes
- 15 x 1W RGB LEDs (5 x Red, 5 x Green and 5 x Blue LED's)
- Rechargeable Lithium battery powered ultra-bright indoor linear fixture



ITEM	DESCRIPTION	PRICE
WIFLY-WASH-BAR	Rechargeable Battery-Powered RGB LED Wash Bar	299.99



AMERICAN DJ WIFLY BAR QA5

- 25° beam angle
- Battery-powered LED bar
- 6 DMX channel modes (4, 6, 7, 8, 9, 22); 6 operational modes
- WiFly Transceiver with wireless DMX built-in (5) 5W QUAD LEDs (4-in-1) RGBA
- Rechargeable lithium battery, runs 6 hours on full charge
- 4-button LED display on rear panel for DMX addressing

ITEM	DESCRIPTION	PRICE
WIFLY-BAR-QA5	Battery-powered RGBA LED bar with wireless DMX	329.99

AMERICAN DJ FLAT PAR QUAD 5

- 40° beam angle
- Low-profile design
- (5) 5W QUAD LEDs (4-in-1) RGBA or RGBW
- In/out IEC connections to daisy chain power
- 44 color macros, color strobe effect and smooth RGB mixing
- 4-button LED DMX display on rear panel; 8 DMX channel modes
- 6 operational modes: manual color, color change, color fade, auto mode, sound active and DMX-512



ITEM	DESCRIPTION	PRICE
FLAT-PAR-QA5	DMX LED slim par (RGBA)	179.99
FLAT-PAR-QWH5	DMX LED slim par (RGBW)	179.99

AMERICAN DJ FLAT PAR QA12

- 40° beam angle
- Low-profile design
- (12) 5W QUAD LEDs (4-in-1) RGBA or RGBW
- In/out IEC connections to daisy chain power
- 44 color macros, color strobe effect and smooth RGB mixing
- 4-button LED DMX display on rear panel; 8 DMX channel modes
- 6 operational modes: manual color, color change, color fade, auto, sound active and DMX-512



ITEM	DESCRIPTION	PRICE
FLAT-PAR-QA12	DMX LED slim par (RGBA)	299.99
FLAT-PAR-QWH12	DMX LED slim par (RGBW)	299.99



Follow Us!

Let us show you exactly what to expect with our lighting design computer modeling and pre-visualization.

LIFT

EMOTIONS WITH PURE
LIGHTING EXCITEMENT



LED SPOTS



**INNO SPOT
PRO**
\$899.99



**INNO SPOT
PRO PEARL**
\$899.99

MOBILE LED SPOTS



**INNO POCKET
SPOT**
\$299.99



**INNO POCKET
SPOT PEARL**
\$299.99

LED BEAMS



**VIZI BEAM
HYBRID 2R**
\$1499.99



INNO BEAM LED
\$799.99

LED PARS



FLAT PAR TW5
\$179.99



FLAT PAR TW12
\$249.99

COB LED



DOTZ BRICK 3.3
\$499.99



DOTZ BAR 1.4
\$199.99

UV LED



UV LED BAR 20
\$299.99



**ECO UV BAR
PLUS IR**
\$149.99



800-356-5844
fullcompass.com

AUDIO



AMERICAN DJ MATRIX BEAM LED

- (25) 3W warm white Cree LEDs in a 5x5 panel
- Latch system links multiple fixtures together
- Designed for use as blinder effect or matrix chase effect
- Built-in light chases, create characters in light via DMX
- 3 operation modes: auto (program run), sound active and DMX512 mode
- 4-button LED DMX display on rear panel; 3 DMX channel modes

ITEM	DESCRIPTION	PRICE
MATRIX-BEAM-LED	DMX 5x5 LED panel	699.99



AMERICAN DJ WIFLY PAR Q45

- 25° beam angle
- Rechargeable lithium battery
- (5) 5W QUAD LEDs (4-in-1) RGBA
- 4-button LED DMX display on rear panel
- WiFly Transceiver wireless DMX onboard
- Battery-powered flat par with wireless DMX
- 8 DMX Channel modes; 6 Operational modes
- Battery-powered flat par with wireless DMX

ITEM	DESCRIPTION	PRICE
WIFLY-PAR-Q45	Battery powered par can with wireless DMX	329.99

AMERICAN DJ WIFLY QA5 IP LED PAR WITH WIFLY TRANSMITTER

- IP65, Outdoor-rated par fixture with 5 x 5W Quad RGBA LEDs
- 40° Beam angle
- Flicker-free operation
- 64 built-in Color Macros
- Creates no RGBA shadows
- Electronic Dimming: 0 - 100%
- Linkable via 3-pin IP cable (In/Out)
- 5 DMX Channel modes and 8 Operational modes



ITEM	DESCRIPTION	PRICE
WIFLY-QA5-IP	Quad LED Par with WIFLY Transmitter	299.99



AMERICAN DJ FLAT PAR TRI 7X

- 40° beam angle
- 32 built-in color macros
- TRI LED (3-in-1) projects no RGB shadows
- Ultra-bright slim par can with (7) 3W TRI LEDs
- 4-button LED DMX display on rear panel; 7 DMX channel modes
- 6 operation modes: manual color model, color change mode, color fade mode, auto mode, sound active mode and DMX512 mode



UNIQUE SIT-FLAT DESIGN

ITEM	DESCRIPTION	PRICE
FLAT-PAR-TRI7X	DMX 3W TRI-LED slim par can	169.99
ADJ-LED-RC	Remote control	19.99



AMERICAN DJ DOTZ TPAR SYSTEM

- 90° Beam angle
- 3-Pin DMX In/Out
- Strobe and Pulse LED Effect
- Pixel Flip option changes pixel orientation
- 5 DMX Channel modes: 3, 5, 9, 12 and 18 channels
- Foot Controller Features: Mode, Black Out and Program Change
- COB Technology produces powerful, smooth RGB color mixing
- 5 selectable Dimming Curves and 4 Operational modes



NEW!

ITEM	DESCRIPTION	PRICE
DOTZ-TPAR-SYSTEM	COB RGB Tri LED Par Wash System	399.99



AMERICAN DJ FLASHBACK 4 PORTABLE LED BOX PANEL EFFECTS FIXTURE

- Set of two 4-bank lighting fixtures that fold up into a transportable hard case
- 45° Beam Angle
- Sound Active knob adjustment on rear
- LED pulse and strobe effect control on rear
- Power Draw: 23W total (All LEDs @ Full On)
- Stand mountable (tripod stands not included)
- LED version of an old school Boarder Can effect
- 2 Operational modes: Auto Run or Sound Active

NEW!

ITEM	DESCRIPTION	PRICE
FLASHBACK-4	RGBA LED Box Panel	149.99

ALTMAN Lighting, Inc.

ALTMAN PHOENIX LED PROFILE SPOT ELLIPSOIDAL

This die-cast aluminum/sheet metal LED fixture features a 360° rotating barrel, locking shutter, heat resistant Plano-Convex lensing (in varying degrees), and tool-free swappable barrels. The color frame, spring clip safety cable, 3' powerCON™ cable and C-Clamp are included. Available in black, white and silver. 250W light engine is fan cooled and available in four versions along with a host of lens tubes. Consult your Sales Pro on options and accessories.



NEW!

ITEM	DESCRIPTION	PRICE
PHX2-RGBA-19-B	Phoenix 250W RGBA LED Profile Spot Ellipsoidal, with 19° lens	1462.50
PHX2-RGBW-19-B	As above, with RGBW LED	1575.00
PHX2-3000K-19-B	As above, with 3000K LED	1687.50
PHX2-5600K-19-B	As above, with 5600K LED	1687.50



APOLLO DESIGN AVERET™ 4UV COMPACT UV LED FIXTURE

- Output: 4,500mW
- Power Consumption: 18.5W
- Radiated Wavelength: 365nm
- 5 High Efficacy UV LED Emitters
- Weatherproof and Fanless Cooling Design
- Machined Aircraft-Grade Black Anodized Aluminum Housing
- 22° Standard Beam TIR Lenses with UV Resistant Polycarbonate



NEW!

ITEM	DESCRIPTION	PRICE
AVERE-4UV	Compact outdoor UV	1134.14

ACCESSORIES



Follow Us!

Let us show you exactly what to expect with our lighting design computer modeling and pre-visualization.



NEW!

**APOLLO DESIGN
AVEREM™ 5 LED
PAR-TYPE FIXTURE**

- 110V or 240V Compliant
- 12° Standard Beam Angle
- Color Rendering Index: 93
- Standard 110V Configuration
- 3000 Kelvin Color Temperature
- 3' Power Cable with Edison Connector
- Turned, Milled and Anodized Aluminum Body
- Includes 20W, 1070 lumens, 50,000-hr Osram Ultra LED HD PAR 38 lamp

ITEM	DESCRIPTION	PRICE
AC-LED-AVID5	LED PAR-type fixture	429.66



**BLIZZARD LIGHTING
ROKBOX EXA LED**



- Built-in sound active programs
- Variable electronic dimming & strobe
- Built-in color & chase macros via DMX
- 5 user-selectable 32-bit dimming curves
- Built-in automated programs via master/slave
- Flicker-free constant-current 400hz LED driver
- (18) 15W (6 x 2.5w) RGBAW+UV 6-in-1 LEDs
- RGBAW+UV color-mixing ability in standalone mode

ITEM	DESCRIPTION	PRICE
ROKBOX-EXA	(18) 15W RGBAW+UV LED Fixture	599.99

**BLIZZARD LIGHTING
ROKBOX™**



- (18) 10W 4-in-1RGBW LEDs
- 3/4/5/8/9 DMX channel modes
- 5 user-selectable 32-bit dimming curves
- Variable electronic dimming and strobe
- Built-in color and chase macros via DMX
- Built-in automated programs via master/slave
- RGBW color mixing ability in standalone mode
- 4-button DMX LED display

ITEM	DESCRIPTION	PRICE
ROK-BOX	LED wash light (RGBW)	399.99



**BLIZZARD LIGHTING
THE PUCK PRO ZOOM™
LED PAR CAN**

- 25°-45° zoom PAR fixture
- Long-life LEDs (rated at 60,000hrs)
- (14) 10W RGBW quad-color TianXin LEDs
- 7 DMX modes, including RGBW and HSV color mixing modes
- Rugged all-aluminum chassis with dual mounting yokes and handle
- User-selectable DMX channel modes, dimming, color temp, power options, color display and more

ITEM	DESCRIPTION	PRICE
PUCK-PRO-ZOOM	LED par can with zoom	399.99



NEW!

**BLIZZARD LIGHTING
COBZILLA™ RGB
5X5 MATRIX PANEL**

- Rugged and well-built
- Sound Active via DMX
- 3-pin & 5-pin DMX I/O
- Lux: 12,100 @ 1m, 4,600 @ 2m
- powerCon™ Compatible Power I/O
- Variable electronic strobe and dimmer
- 1/2-turn coffin-lock fixture link brackets
- Easy to use 4 button LCD Control Panel
- Built-in automated programs via master/slave
- 25 x 9W 3-in-1individually controllable COB (Chip-On Board) RGB LED's

ITEM	DESCRIPTION	PRICE
COBZILLA-RGB	COB RGB LED Pixel Matrix	1199.99



**BLIZZARD LIGHTING
SKYBOX EXA LED PAR**

- RGBAW + UV Color Mixing
- 7x15W 6-in-1 LEDs w/ 100,000 hrs life
- 395-400nm ultraviolet light output
- 2.4Ghz built-in wireless DMX receiver
- Intelion™ lithium-ion battery system
- 5 user-selectable 32-bit dimming curves
- Beam Angle: 25° optics standard, 26° beam, 30° field

ITEM	DESCRIPTION	PRICE
SKYBOX-EXA	6x1 RGBAW+UV LED Par fixture	499.99

NEW!



**BLIZZARD LIGHTING
HIGHBEAM™ RGBW LED
BEAM PAR-TYPE FIXTURE**

- Built-in color and chase macros via DMX
- 3-pin male input, 3-pin female output
- RGBW color mixing ability in standalone mode
- Super-quiet variable-speed internal fan cooling
- Flicker-free constant-current 400hz LED driver
- powerCon™ compatible AC power In/Out connectors
- 4 DMX control modes as well as built-in sound active programs
- Color mixing and 4-zone pixel control via 7 x 15W OSRAM® RGBW 4-in-1 LEDs

ITEM	DESCRIPTION	PRICE
HIGHBEAM	Indoor RGBW LED PAR-Type Fixture	599.99

**BLIZZARD LIGHTING
ROCKLITE™ RGBAW
WASH LIGHT**



- 4/5/9/10 DMX channels
- 23° beam angle, 26° field angle
- LED display with 4-button control panel
- (36) 3W RGBAW Edison® Edixeon™ LEDs
- RGBAW color mixing with or without DMX control
- Master/slave, standalone and sound active modes
- Built-in color macros and automated programs via DMX

ITEM	DESCRIPTION	PRICE
ROCKLITE-RGBAW	LED wash light (RGBAW)	399.99



AUDIO



BLIZZARD LIGHTING
SNOWBANK™ RGB
BLINDER/LED PIXEL EFFECT



- 45° Beam Angle
- 400Hz flicker-free LED drivers
- 3-pin male input, 3-pin female output
- Easy to use LED digital control panel
- Protocol: USITT DMX-512 (26/7 Channels)
- Standalone, master/slave, and DMX modes
- Dual mounting yoke allows flexibility in positioning
- RGB color mixing via 32 x 3W Tri-Color (3-in-1) LEDs
- Built-in automated and sound activated programs via master/slave

ITEM	DESCRIPTION	PRICE
SNOWBANK	RGB Blinder/LED Pixel Effect	399.99

BLIZZARD LIGHTING
PUCK Q12 FLAT
LED PAR CAN



- Selectable 4 or 7 DMX channels
- Variable electronic strobe and dimmer
- All metal case with dual mounting yokes
- Linkable with all other Blizzard Puck par cans
- (12) 10W Quad-Color (RGBW or RGBA) LEDs
- Full RGBW or RGBA color mixing plus 15 built-in colors in standalone, master/slave and DMX modes

ITEM	DESCRIPTION	PRICE
PUCK-Q12W	Quad-color flat par can (RGBW)	279.99
PUCK-Q12/A	Quad-color flat par can (RGBA)	279.99

darklight
Precision Lighting System

DARKLIGHT PRECISION
DMX MICRO RGB FLOOD



PRECISION-DMX COMPACT SIZE

- IP65 rating
- 7-channel DMX control
- 25° lens angle, 50,000hr lamp life
- DMX address and configuration stored in EEPROM
- World's smallest DMX512 controllable theatrical floodlight
- Full color control via DMX512; DarkBox Programmer (sold separately) required to change DMX from default address 1
- Built-in functions: flicker, strobe, blink, fade, color change, master dimming, color macro

ITEM	DESCRIPTION	PRICE
PRECISION-DMX	Miniature DMX RGB flood	114.00
DARKBOX-PROGRAMMER	DMX addressing tool	95.00

THE WORLD'S SMALLEST GOBO PROJECTOR
GANTOM IQ



DARKLIGHT GANTOM IQ
MICRO IMAGE PROJECTOR

- IP65 rating
- Dual-polarity input
- Smallest gobo projector on the market
- Zoom- and focus-adjustable with sliding lenses
- 2-wire dimming using PWM input (10%-100%)
- Supports full-color, user-made 3/4" patterns
- 25°-40° lens angle, 50,000hr lamp life

ITEM	DESCRIPTION	PRICE
GANTOM-IQ	Miniature gobo projector	247.00

darklight
Precision Lighting System

DARKLIGHT
PRECISION-Z HIGH POWER
MICRO SPOT OR FLOOD



PRECISION-Z-FLOOD

PRECISION-Z COMPACT SIZE

- Dual polarity input
- IP68 rating, submersible to 3ft
- 2-wire dimming using PWM input (10%-100%)
- Equivalent to traditional 20W halogen fixtures
- 95% energy savings compared to 20W halogen lamp
- Lens angle is 15° for spot and 120° for flood, 50,000hr lamp life
- Spot is available in red, green, blue, amber, cool white, warm white and ultraviolet

ITEM	DESCRIPTION	PRICE
PRECISION-Z-SPOT	Miniature spot	47.50
PRECISION-Z-FLOOD	Miniature flood	47.50

DARKLIGHT
GANTOM DMX
MICRO FLOOD



GANTOM-DMX COMPACT SIZE

- IP65 rating
- Flicker-free and video-ready
- 20° lens angle, 50,000hr lamp life
- Integrates into any existing DMX universe
- DMX address and configuration stored in EEPROM
- Available in RGBW (4-channel) or dynamic white (2-channel)
- Quad-chip LED and matching optics for homogenous color output

ITEM	DESCRIPTION	PRICE
GANTOM-DMX	Miniature DMX flood	180.50

darklight
Precision Lighting System

DARKLIGHT
DARKBOX
CONTROLLERS



DARKBOX-FLICKER

DARKBOX-DMX-MICRO

DARKBOX-PROGRAMMER

Compact and versatile controllers. The Flicker and DMX Micro versions offer simple operation, LED indicators, can drive multiple fixtures in sync and make any 12V LED flicker, strobe, blink, surge, pulsate, or dim. The Flicker can also generate patterns and the DMX Micro has fully-tunable speed and brightness for any mode. The Programmer is compatible with all DMX devices and functions as a DMX addresser and configurator. It even has a built-in 224-channel single scene output and DMX controller for use with static effects.

ITEM	DESCRIPTION	PRICE
DARKBOX-FLICKER	LED dimmer and pattern generator	57.00
DARKBOX-DMX-MICRO	Multi-functional LED dimmer	66.50
DARKBOX-PROGRAMMER	DMX addresser and configurator	95.00

ELATION
PROFESSIONAL



ELATION CUEPIX
BATTEN TRI

- Pixel Control of each COB
- 614 lux @ 3M 60° Standard Beam Angle
- Variable / Selectable Dimming Curves
- DMX control with built-in effect macros
- 1x8 30W Chip-On-Board (COB) RGB LED Batten

ITEM	DESCRIPTION	PRICE
CUEPIX-BATTEN-TRI	1x8 COB RGB LED batten fixture	649.99



Follow Us!

Let us show you exactly what to expect with our lighting design computer modeling and pre-visualization.



ELATION EPAR TRI LED PAR CAN

- (14) 3W Tri RGB LEDs
- 10° standard beam angle
- Dual-yoke floor stand
- No colored shadows
- Flicker-free operation
- Long life 50,000hr LEDs
- 4-digit LED display
- 0-100% electronic dimming
- 1/2/3/4/6/7 DMX channel operation mode



ITEM	DESCRIPTION	PRICE
EPAR-TRI	LED par can	251.93

ELATION EPAR QA LED PAR CAN

- (14) 5W Quad RGBA LEDs
- 10° standard beam angle
- Dual-yoke floor stand
- No colored shadows
- Flicker-free operation
- Long life 50,000hr LEDs
- 0-100% electronic dimming
- 4-digit LED display
- 1/2/3/4/6/7 DMX channel operation mode



ITEM	DESCRIPTION	PRICE
EPAR-QA	LED par can	449.99

ELATION VOLT Q5 WEATHERPROOF LED SPOT

- 16,000 lux @ 8ft
- (5) 15W RGBW LEDs
- Built-in wireless DMX receiver
- Excellent color mixing and tight beam
- Weather-resistant housing with IP65 rating
- Rechargeable battery with charging station
- Compact and solid design with built-in handle
- 4-button LED control panel for easy programming



ITEM	DESCRIPTION	PRICE
VOLT-Q5	IP65 rated LED spot	1699.99

SIX-PAR-200-IP

SIX-PAR-100-IP



ELATION SIX PAR FAMILY

- 6-Color RGBAW+UV 12W per node
- 7x12W/12x12W/18x12W
- IP 65 Rated LED Series
- Variable/Selectable Dimming Curves
- IR Remote Control Option
- IP Power/Data linking cables

ITEM	DESCRIPTION	PRICE
SIX-PAR-100-IP	6-color 80W IP 65 rated LED	449.99
SIX-PAR-200-IP	6-color 120W IP 65 rated LED	549.99
SIX-PAR-300-IP	6-color 200W IP 65 rated LED	699.99



ELATION LIGHTING DESIGN CUEPIX PAR 150 / 300

- IR Remote Control Option
- Variable / Selectable Dimming Curves
- 3- & 5-Pin DMX in/out – Powercon in/out
- Pixel Control of each Chip-On-Board (COB) module



ITEM	DESCRIPTION	PRICE
CUEPIX-PAR-150	4x30W COB RGB Par 150 fixture	499.99
CUEPIX-PAR-300	7x30W COB RGB Par 300 fixture	699.99



ELATION LEVEL Q7 LED FLAT PAR FIXTURE

- Weighs 10lbs
- 14,700 lux @ 2.5m
- 3- and 5-pin DMX
- Neutrik® PowerCon in/out
- (7) 15W RGBW OSRAM Quad LEDs
- High-output and professional grade

ITEM	DESCRIPTION	PRICE
LEVEL-Q7	Quad LED par fixture	899.99

ELATION OPTI QUAD PAR QUAD LED PAR FIXTURE

- Flicker free
- Power con in/out
- 18 x 5W quad RGBW LEDs
- Quad color technology
- Smooth dimming control
- 10° standard beam angle
- Power Consumption: 140W max
- Strobe effect (1-18 flashes per second)
- DMX-512- controllable via 6 DMX modes
- Split yoke bracket: floor-stand or mount
- 3-pin and 5-pin XLR data input and output



ITEM	DESCRIPTION	PRICE
OPTI-QUAD-PAR	Quad LED Par Fixture	799.99



ELATION FLEX PIXEL WP LED PIXEL TAPE

- Flex Pixel IR allows for standalone control
- 10' flexible LED pixel tape with waterproof cover
- Mountable to any surface with optional Flex IP Clip Kit
- 15mmW x 5mmH x 3mTRL (not including in/out cables)
- Flex Pixel 5VPSU power supply required for each section of tape
- Flex Pixel Driver offers up to 2 tapes and up to 432 DMX channels of control
- (72) RGB SMD tri color LED pixels (216 ch.) per tape spaced on 40mm centers

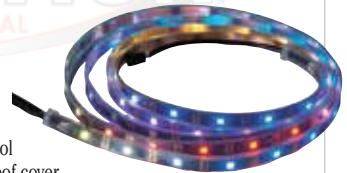

ITEM	DESCRIPTION	PRICE
FLEX-PIXEL-WP	LED pixel tape, power supply not included	119.99
FLEX-IP-CLIP-KIT	Mounting clip to mount to any surface	6.68
FLEX-PIXEL-DRIVER	DMX driver	74.99
FLEX-PIXEL-IRC	IR receiver and remote	37.99
FLEX-PIXEL-5VPSU	5V standard power supply unit	29.99



AUDIO



ELATION ARENA PAR ZOOM WITH QUAD COLOR

- Variable Strobe Macros
- 10° - 60° Motorized Zoom
- Selectable Dimming Curves
- 220W Max Power Consumption
- Flicker Free Operation for TV and film
- Integrated Dual Rigging Yoke / Floor Stand
- 1000W Comparable Output LED PAR 64
- (19) 10W Quad Color (RGBW) LEDs
- Power Link Up To (4) Units at 120V (8) Units at 230V



ITEM	DESCRIPTION	PRICE
ARENA-PAR-ZOOM	19x10W Quad Color LED Par	1399.99



ELATION PROTRON LED STROBE LIGHT

- (576) 6500K white LEDs
- 28,000 lumens
- 120° beam angle
- IP65 rugged die cast case
- DMX and RDM control
- Full ON mode, bursts and linear dimming
- IP Rated PowerCon In and Thru connections
- 100-240V AC Auto Sensing, 150W

ITEM	DESCRIPTION	PRICE
PROTRON-LED-STROBE	LED strobe light	849.99



ELATION OPTI TRI WHITE II™ LED FIXTURE

- 20° standard beam lens
- 5 variable dimming curve modes
- Dual yoke / floor stand
- Multi-unit power linking
- Rugged die-cast aluminum exterior
- Flicker-free operation for TV and FILM
- 200W max power consumption
- Electronic strobe and dimming (0-100%)
- Multi-voltage universal auto switching power supply (110-250v)
- (18) 10W Multi-Chip Variable White (Cool, Warm, and Amber) LEDs

ITEM	DESCRIPTION	PRICE
OPTI-TRI-WHITE-II	Tri White™ LED fixture	699.99

ELATION ARENA Q7 ZOOM™

- (7) 10W QUAD Color LEDs
- 10° - 60° motorized zoom
- Multi-unit power linking
- Variable strobe macros
- Selectable dimming curves
- 4-button touch-control panel
- Flicker-free operation for TV and FILM
- Integrated dual rigging yoke / floor stand
- 5-pin DMX and powerCON I/O connections
- Multi-voltage universal auto switching power supply (100-240v)



NEW!

ITEM	DESCRIPTION	PRICE
ARENA-Q7-ZOOM	7x10W RGBW Par-type fixture with zoom	899.99

Martin



MARTIN RUSH STROBE 1 5X5

- 3-pin and 5-pin XLR
- 5x5 matrix panel
- DMX or sound activated
- (25) 5W Cree cool white LEDs
- Individually controllable LEDs
- Preprogrammed macros (effects, letters, numbers, etc.)
- Linkable – integrated horizontal and vertical locking
- Multiple DMX control options and standalone mode

ITEM	DESCRIPTION	PRICE
RUSH-STROBE	LED strobe/blinder	995.00



MARTIN RUSH PAR 1 RGBW

- 2 DMX channel modes (5/7)
- 20° fixed beam angle
- Premixed RGBW color mixing
- Electronic dimming and strobe
- (7) 10W RGBW Cree MC-E LEDs
- DMX and standalone control options
- Flexible bracket for floor or truss mounting

ITEM	DESCRIPTION	PRICE
RUSH-PAR-1	LED par can	495.00



MARTIN RUSH PAR 2 RGBW ZOOM

- 5-pin XLR
- 10° to 60° Zoom
- Bright LED PAR Can
- (12) 10 W RGBW LEDs
- Electronic dimming and strobe
- Temperature-controlled fan cooling
- Flexible bracket – floor or truss-mounted
- Single-lens wash with fully premixed color
- Bullet points features and benefits

ITEM	DESCRIPTION	PRICE
RUSH-PAR2-RGBW-ZOOM	LED PAR Can with 12 RGBW LEDs	895.00

ROSCO MIRO CUBET™ FAMILY

These 48W LED wash lights put more than 3000 lumens into a compact and portable 4" cube. The rugged, geometric design is perfect for museums, track-light systems, in stores and lobbies or built into sets, truss and lighting rigs.



- Bolted yoke design allows units to be easily ganged
- Flicker-free dimming through DMX (8- or 16-bit resolution)
- Plugs directly into wall anywhere in the world, adjusting automatically to 90-240VAC 50-60Hz
- More than 40 units can be powered from a single 20A circuit LCD control panel
- Full color mixing, tunable white, or black light versions (in black or white finish)

ITEM	DESCRIPTION	PRICE
MIROCUBE-4C	Color-mixing LED wash	820.31
MIROCUBE-WNC	Tunable white LED wash	820.31
MIROCUBE-UV	Blacklight LED wash	1257.81



Follow Us!

Let us show you exactly what to expect with our lighting design computer modeling and pre-visualization.



AMERICAN DJ ILLUSION DOTZ 4.4

- 15° beam angle
- 100,000 hour lamp life
- 16 x 30W RGB COB LEDs
- Weight: 18 lbs
- RJ45 I/O for Artnet/KlingNet Control
- DMX Channels: 12, 14, or 59; 3 and 5 Pin I/O
- Daisy chain up to 3 units @ 120V
- Power Draw: 468W max., 3.9A @ 120V

ITEM	DESCRIPTION	PRICE
ILLUSION-DOTZ-4.4	LED Pixel Effect Moving Head Fixture	1499.99

NEW!



AMERICAN DJ VORTEX 1200

- 23 Built-In Color Macros
- Effect Zoom: 5° ~ 44° beam angle
- Includes Omega bracket for truss mounting
- 12x10W RGBW Quad Color (4-IN-1) LEDs
- Power Draw: 174W total (All LED's @ Full On)
- PowerCON™ AC In/Out on rear to daisy chain power
- 4 DMX channel modes, 3 Operational Modes and 5 selectable Dim Curves
- 16-piece lens kit rotates continuous 360 degrees clockwise or counter-clockwise
- Unique Moving Head with a Moonflower type effect that produces hundreds of beams of light

ITEM	DESCRIPTION	PRICE
VORTEX-1200	RGBW Moving Head Wash - Effect LED Light	999.99

NEW!



AMERICAN DJ INNO COLOR BEAM Z RGBW LED

- 14 DMX channels
- Pan: 540°; Tilt: 220° (16-bit)
- 64 Built-In Color Macros
- Controlled operation modes
- Stepper motors with micro stepping
- Motorized Zoom: 10 ~ 60° beam angle
- RGBW Quad Color (4-in-1) Osram LEDs
- Sound-Activated, Show Mode, & DMX-Pan/Tilt Inverse Mode for contrasting movement when fixtures are linked together
- Includes Omega bracket for truss mounting Electronic slow-to-fast random strobe/pulse effect

ITEM	DESCRIPTION	PRICE
INNO-COLOR-BEAM-Z7	7x10W RGBW Quad Color LED moving head beam fixture	999.99
INNO-COLOR-BEAM-Z19	19x10W RGBW Quad Color LED moving head beam fixture	1699.99

AMERICAN DJ INNO SCAN LED

- 9° beam angle
- Built-in lighting programs
- 50W LED DMX512 scanner
- Replaceable gobos
- Separate color/gobo wheels, 8 colors + white, 6 rotating gobos + spot
- 3 operation modes: master/slave, sound active and DMX512 mode
- 4-button LED DMX display on rear panel; 2 DMX channel modes

ITEM	DESCRIPTION	PRICE
INNO-SCAN-LED	50W LED scanner	440.93



AMERICAN DJ 3 SIXTY 2R DUAL MOVING HEAD FIXTURE

- 8-facet prism
- 13 colors + White
- Auto X-Y repositioning
- 6-Button, full color LCD
- Frost filter for wash effect
- 14 rotating fixed gobos + open spot
- Separate, static Color & Gobo Wheels
- 3-pin XLR chassis-mount DMX connectors
- 360° continuous Pan/Tilt movement/rotation
- Shutter has slow-to-fast random strobe pulse effect
- Comes w/ bright white Phillips MSD Platinum 2R lamp
- 3 Operational modes: DMX, Master/Slave and Sound-Activated
- 3 DMX Channel modes: Standard, Basic and Extended (21, 24, 32 Ch)

ITEM	DESCRIPTION	PRICE
3-SIXTY-2R	Dual Moving Head fixture	2799.99



AMERICAN DJ SWEEPER BEAM LED MOVING BAR

- (8) 3W white Cree LEDs
- Long Life (50,000 hr. rated)
- 3.5° Beam angle, 270° tilt
- Quick sweeping narrow beams
- 1-, 6-, 11-, 15-Channel DMX modes
- DMX controller, Master/Slave & Sound-Activated operational modes
- 8-zone LED chase, LED pulse & strobe effect



ITEM	DESCRIPTION	PRICE
SWEEPER-BEAM-LED	8-Zone LED Moving Bar fixture	349.99

AMERICAN DJ CRAZY 8

- 8-Zone Dual LED Bars, each with 4 lenses, move independently
- Beam angle: 4.5°
- 8 x 8W White LEDs
- LED pulse and strobe effect
- Includes built-in sound activated programs
- 5 DMX Channel modes and 3 Operational modes
- Power Consumption: 90W (All LED's @ Full On)
- 540° base pan, 150° bar tilt from smooth Stepper Motors
- powerCON™ on rear to daisy chain power

ITEM	DESCRIPTION	PRICE
CRAZY-8	Dual Bar Moving Head Fixture	999.99

NEW!



AMERICAN DJ INNO SPOT PRO LED MOVING HEAD

- 14 DMX channels
- Gobo Shake effect
- 4 built-in lighting shows
- Pan: 540°, Tilt: 270° (16-bit)
- 12° - 17° adjustable manual zoom
- Separate color & gobo wheels (size: 24mm)
- DMX-512, Sound-Activated or Show Mode operation modes
- 8 Colors + Spot; 6 Rotating Replaceable Gobos + open; 3-Facet rotating prism

ITEM	DESCRIPTION	PRICE
INNO-SPOT-PRO	Compact intelligent 80W LED moving head fixture	899.99

AUDIO



Shop fullcompass.com today!

For expert advice - call: 800-356-5844

M-F: 9:00-5:30 Central

- AUDIO
- MUSIC
- COMPUTER AV
- VIDEO
- LIGHTS
- ACCESSORIES



AMERICAN DJ INNO SPOT LED WIFLY

NEW!

- 8 colors + white
- 540° pan / 270° tilt (8-bit)
- Built-in lighting programs
- 6 rotating, replaceable gobos + spot
- Built-in ADJ WiFly Transceiver Wireless DMX
- Power consumption: 99W total (All LED's @ Full)
- 50W White LED source (Rated at approximately 50,000 hours)
- 4 Operational modes: DMX Controlled, WiFLY DMX, Show Mode or Sound Active



ITEM	DESCRIPTION	PRICE
INNO-SPOT-LED-WIFLY	Compact Moving Head LED with WiFly	699.99



BLIZZARD LIGHTING HELIOS SPOT MOVING HEAD SPOT LED

- 2 Gobo Wheels
- Pan 540° / Tilt 270°
- 40,700 Lux @ 1m | 12,300 Lux @ 2m Red
- Butterfly 150W RGBW LED Module
- RGBW Full Color without color wheel



ITEM	DESCRIPTION	PRICE
HELIOS-SPOT	150W moving head spot fixture	2799.99



BLIZZARD LIGHTING BLADE RGBW MOVING HEAD

- Neutrik® powerCON in/out
- User-selectable 16-bit dimming
- User-selectable, 11 or 15 DMX channels
- (36) 5W CREE® RGBW quad-color LEDs
- 4-button menu with LCD-TFT icon-based display
- Defeatable pan/tilt correction with trim adjustment
- Razor-sharp 1.1° beam angle + attachable 8° diffuser lens
- Full color mixing in standalone, master/slave and DMX modes



ITEM	DESCRIPTION	PRICE
BLADE-RGBW	LED moving head with 1.1° beam angle	599.99



ELATION PLATINUM BX PRO™

- Powerful 2.5° beam
- 8-facet rotating prism
- 13 fixed / indexing gobos
- 500W max power consumption
- 15,000 total lumens, 6,900K, 85CRI lamp
- Phillips™ MSD Platinum 17 RA 350W lamp
- 11 dichroic colors including UV, CTB, CTO, + White
- 3 and 5 pin DMX in/out and powerCON connections
- (6) button control full color 180° reversible menu display
- Multi-voltage universal auto switching power supply (100-240v)

NEW!



ITEM	DESCRIPTION	PRICE
PLATINUM-BX	Moving head beam fixture	4699.99



ELATION PLATINUM SBX PRO™

- 6-Button Touch Control Panel
- 15,000 Total Lumens, 6,900K, 85CRI
- 0° - 15° Beam and 5° - 40° Spot Zoom
- Comparable Output to 700W Fixtures
- Internal EWDMMX Wireless DMX Receiver
- Phillips™ MSD Platinum 17 RA 350W Lamp
- Full Color 180° Reversible LCD Menu Display
- Beam Shaping and 8-Facet Prism and 16 Prism Macros
- 9 Rotating Interchangeable & 14 Fixed / Indexing Gobos
- 13 Dichroic Colors Including UV, CTB, CTO, + White (open)
- Patent Pending 3-in-1 Fixture - Beam, Spot, and Wash Luminaire
- (3) DMX Channel Modes and RDM (Remote Device Management)

NEW!



ITEM	DESCRIPTION	PRICE
PLATINUM-SBX	Moving head beam, spot and wash fixture	CALL

ELATION PLATINUM PROFILE 35 PRO

NEW!



- 2 Gobo Wheels
- 160° Animation Effect
- Strobe and 5% - 100% Iris
- 3 DMX Channel Modes (37/39/60)
- 3-Facet Prism and 16 Prism Macros
- Built-In EWDMMX Wireless DMX Receiver
- 8 Interchangeable Dichroic Colors Including UV + CTB
- Motorized 8° - 50° Zoom + 4 Blade Framing system w/ rotation
- Full Color 180° Reversible LCD Menu Display



ITEM	DESCRIPTION	PRICE
PLAT-PROFILE-35-PRO	Moving Head Fixture	CALL

ELATION SATURA SPOT LED PRO

- Max 5,410 LUX @5M 12° min zoom
- 12° to 38° zoom / prism / iris / focus
- 540°/630° pan, 245° tilt
- EWDMMX wireless DMX receiver
- 3 DMX Channel Modes (21/19/25)
- Microphone for sound activated programs
- Rechargeable backup battery for menu display
- Standalone operation with master/slave function
- Full color 180° reversible LCD menu display
- 300W RGBW LED color mixing engine, comparable to 575W discharge



ITEM	DESCRIPTION	PRICE
SATURA-SPOT-LED-PRO	LED moving head	CALL



ELATION RAYZOR Q7 MOVING HEAD LED WASH

- (7) 15W Quad RGBW LEDs
- 17° beam angle, 13° field angle
- Pan: 540°/630°; Tilt: 265°
- 5,442 lux @ 4M
- 5-pin in/out DMX connectors
- 15/17/28 DMX channels
- Long life 50,000 hour LEDs
- 0-100% electronic dimming
- Color LED touch display

ITEM	DESCRIPTION	PRICE
RAYZOR-Q7	Moving head LED wash	1349.99



Follow Us!

Let us show you exactly what to expect with our lighting design computer modeling and pre-visualization.



**ADD
PERFORMANCE &
SOPHISTICATION TO
YOUR VISION.**

FROM LOUNGES TO
LARGE STADIUMS,
ELATION® PROFESSIONAL HAS
THE RIGHT SOLUTIONS.

HIGH OUTPUT
ENERGY EFFICIENT
LED FIXTURES

the **POWER** to **ACHIEVE**
your **VISION**



RAYZOR
Q12 ZOOM



PLATINUM
PROFILE LED



SATURA SPOT
CMY PRO
COOL WHITE
LED ENGINE



SATURA SPOT
LED PRO
RGBW LED ENGINE



800-356-5844
fullcompass.com

PRO AUDIO · VIDEO · LIGHTING
MUSICAL INSTRUMENTS

AUDIO



ELATION LIGHTING DESIGN WASH LED ZOOM

- Pan: 540° or 630° (User-Selectable)
- Tilt: 265°
- 4-Button LCD Control Panel
- 7 Internal Auto Programs
- Single Omega Bracket Mounting
- Flicker-Free Operation for TV and Film
- Microphone for Sound-Activated Programs
- High Speed 16-Bit Resolution Movement
- Standalone Operation with Master/Slave Function
- 7°- 30° Beam angle Zoom Range, 13°-40° field angle



ITEM	DESCRIPTION	PRICE
DESIGN-WASH-LED-ZOOM	324W moving head LED wash fixture	1999.99



ELATION DESIGN PLATINUM BEAM 5R

- 34 lbs
- 12 dichroic colors
- 8 rotating, replaceable gobos
- 8-facet rotating prism
- Frost filter (hybrid wash effect)
- Variable speed shutter/strobe
- Power: 305W MAX/120v 60hz
- 3-pin and 5-pin DMX
- Rotating gobos and 3 facet prism

- Featuring Philips MSD Platinum 5R lamp
- Extreme ACL / beam effect-2.5° beam angle

ITEM	DESCRIPTION	PRICE
PLATINUM-BEAM-5R	Moving head beam fixture	1599.99

ELATION RAYZOR Q7 ZOOM / Q12 ZOOM

- 8 macros
- DMX or RDM protocol
- Zoom & zone chase effects
- 16-bit 3-phase pan/tilt motors
- 15/17/29 DMX channels, 37 max CHs on the Q12



ITEM	DESCRIPTION	PRICE
RAYZOR-Q7-ZOOM	7x15W RGBW Quad LED wash moving head with zoom	1599.99
RAYZOR-Q12-ZOOM	12x15W RGBW Quad LED wash moving head with zoom	1999.99



ELATION PLATINUM WASH 16R PRO

- 330W Platinum 16R Wash/Beam
- 6.5° - 48° motorized zoom
- 13,720 LUX @ 15M, 8000K, >75 CRI, 1500 hrs
- CMY color mixing, 6 static colors including UV and CTO
- Light and heavy frost, beam shaping, rotating prism
- 16-Bit resolution on all motor functions

ITEM	DESCRIPTION	PRICE
PLATINUM-WASH-16RPRO	450W moving head fixture	3999.99



ELATION PLATINUM BEAM 15R PRO

- 8 facet prism
- 10 dichroic colors
- Weight: 51 lbs.
- Built-in EWDMX receiver
- Razor-sharp 4.8° very narrow ACL beam
- Uses Philips MSD Platinum 15R lamp
- 17 gobos- 8 rotating/indexing, 9 static
- Variable speed strobe effect
- 3-pin and 5-Pin XLR serial input/output
- Power consumption: 500W max.
- Variable frost filter (hybrid effect for wash)
- Electronic ballast & auto switching power supply

ITEM	DESCRIPTION	PRICE
PLATINUM-BEAM-15RPRO	Moving head beam fixture	2339.94

Martin

MARTIN RUSH MH 1 PROFILE

This LED moving head offers a variety of effects and colors thanks to its 2 gobo wheels (1 rotating, 1 fixed) and 2 color wheels. Also features electronic dimmer and strobe, motorized focus and iris, and 3-facet prism effects. In stand-alone mode, the fixture can be auto triggered or music triggered, can run 4 pre-programmed shows and has a memory of 20 scenes. DMX data I/O via 3 & 5-pin locking XLR. Includes 5 ft. power cable. For indoor use only.



ITEM	DESCRIPTION	PRICE
RUSH-MH1-PROFILE	LED moving head with 2 gobo wheels, 2 color wheels	1995.00



MARTIN MAC AURA™ COMPACT LED MOVING HEAD WITH ZOOM

- RGBW color mixing
- 11° to 58° zoom
- 3850 lumens
- Built-in FX engine
- 4000 lumen output
- Low power consumption and quiet cooling system
- Single lens wash fixture with fully pre-mixed color

ITEM	DESCRIPTION	PRICE
MAC-AURA-BLACK	LED moving head	3770.00

MARTIN RUSH MH 3 BEAM MOVING HEAD FIXTURE

This moving head produces a narrow long-throw beam that creates cool mid-air looks and effects. Features a fixed 17-gobo wheel and a 14-color wheel. Effects include dimmer, strobe, frost, motorized zoom, 8-facet prism, and motorized focus. Also features 31 pre-programmed pan and tilt macros. DMX data I/O via 3 & 5-pin locking XLR. Includes 5 ft. power cable & mounting brackets. For indoor use only.



ITEM	DESCRIPTION	PRICE
RUSH-MH3-BEAM	Beam moving head fixture	2495.00



Follow Us!

Let us show you exactly what to expect with our lighting design computer modeling and pre-visualization.

Martin

NEW!

MARTIN MAC QUANTUM WASH™

- 750W RGBW LED Washlight
- 50 x 15W RGBW LEDs
- Super high-speed movements
- Compact form factor and rugged construction
- Unique and expressive Colororganics™ system
- Beam effects: Beam twister, light and color morphing, color spin
- Shutter effect: Electronic, with variable speed regular and random strobe
- Pre-programmed effects: Range of synchronized and independent color, intensity, beam twister and zone effects



ITEM	DESCRIPTION	PRICE
MARTIN MAC-QUANTUM-WASH	LED Wash Fixture	CALL



NEW!

MARTIN MAC QUANTUM PROFILE™

- Low weight and compact design
- Color wheel: 6 color filters plus open
- Flat field, crisp image, high contrast
- Beam effects: Rotating multi-facet prism
- Color mixing: CMY, independently variable 0 - 100%
- Full feature set including color mixing & 1:3 zoom
- Consistent photometric performance via LED technology
- 10-position static gobo wheel plus 6-position rotating gobo wheel

ITEM	DESCRIPTION	PRICE
MARTIN MAC-QUANTUM-PROFILE	LED Moving Profile	CALL

MARTIN MAC-101 LED MOVING HEAD WASH LIGHT

- Martin's fastest moving head
- Calibrated colors
- 2200 lumen output
- Variable CTC
- Smooth electronic dimming (0-100%, with 4 curve options)
- 13.5° one-tenth peak angle
- Electronic strobe with pulse
- Efficient and consumes little power
- Easily daisy-chainable & weighs only 8.2 lbs
- 8/12 DMX channels via 5-pin locking XLR
- AC power in & thru via Neutrik Power Con

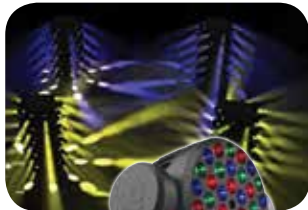

ITEM	DESCRIPTION	PRICE
MARTIN MAC-101	LED moving head wash light	1470.30



MARTIN RUSH MULTIBEAM 2

- Mid-air effects
- Preprogrammed macros
- (10) individually controllable 10 W RGBW LEDs
- Electronic dimming and variable strobe effect
- (2) moveable LED bars each with (5) individually controllable narrow beams
- Master/slave function and DMX or sound activation modes

ITEM	DESCRIPTION	PRICE
MARTIN RUSH-MULTIBEAM-2	DMX controllable effects fixture	995.00



NEW!

MARTIN RUSH MH 5 PROFILE This compact and bright 75W LED profile moving head with efficient optics punches out a variety of effects and colors. With (2) color wheels (2) gobo wheels and rotating 3-facet prism the MH 5 Profile offers full effects in a super compact housing, making it perfect for DJs, bands, and other installations where a small footprint and low weight is critical. 16-channel DMX control is via 3 and 5 pin XLR, with stand-alone trigger and sequence option capability.



ITEM	DESCRIPTION	PRICE
MARTIN RUSH-MH5-PROFILE	Moving head LED spotlight	1269.45



MARTIN RUSH MH 2 WASH

This powerful, fast and agile compact LED wash light moving head features RGBW color mixing (7x 10W LEDs) and has a 20° beam angle. Unique wash beam effects are possible via electronic dimming and strobe. In stand-alone mode, the fixture can be auto triggered or music triggered, can run 4 pre-programmed shows and has a memory of 20 scenes. DMX data I/O via 3 & 5-pin locking XLR. Minimum LED lifetime of 50,000 hours. For indoor use only. Includes 5 ft. power cable.

ITEM	DESCRIPTION	PRICE
MARTIN RUSH-MH2-WASH	Compact RGBW LED moving head fixture	1095.00

MARTIN RUSH WIZARD

- Adjustable focus
- 130 W short-arc discharge with reflector
- DMX, music-triggered, or stand-alone mode
- Shutter: Strobe effect, pulse effects, instant open and blackout
- Flexible mounting bracket for floor stand, wall or ceiling mounting
- 80 agile light beams with chase and changing color/gobo pattern effects
- 2 independent color/gobo wheels w/ 7 colors, 2 white, 13 patterns



ITEM	DESCRIPTION	PRICE
MARTIN RUSH-WIZARD	DMX-controllable effects light fixture	1395.00



MARTIN RUSH MH 4 BEAM

- 6-facet prism
- 3 & 5 pin XLR
- Motorized focus
- Mid-air looks & effects
- Color wheel & fixed gobo wheel
- Mechanical dimming and strobe
- Sharp, narrow long-throw beam
- Compact beam moving head fixture for smaller venues

ITEM	DESCRIPTION	PRICE
MARTIN RUSH-MH4-BEAM	Compact moving head fixture	1895.00

AUDIO



Shop fullcompass.com today!

For expert advice - call: 800-356-5844

M-F: 9:00-5:30 Central



AUDIO



MUSIC



COMPUTER AV



VIDEO



LIGHTS



ACCESSORIES



ANTARI Z-350 FAZER Air pump technology enables this unit to generate a dry haze and provides its heater with self-cleaning functionality. It comes with a larger diameter tube which substantially reduces the risk of heater clog. An extremely low fluid consumption rate allows a full tank to produce 430 minutes of non-stop hazing at maximum output. New on-board DMX design allows users to have control from their console without needing to add additional modules.



ITEM	DESCRIPTION	PRICE
Z-350	Fazer, 1.3-liter tank, on-board DMX	399.99
FLG-4	Heavy fog liquid, 5 liters, non-toxic	33.68

ANTARI HZ-350 HAZE MACHINE An innovative LCD control panel is now built into the machine, so you can master this classic haze machine with minimal effort. The digital LCD control system allows users to set the timer and DMX address directly and accurately, just by moving their fingertips. A wireless on/off control is another useful feature for users who need to execute the output timing manually. Optional HC-1 timer remote also available.



ITEM	DESCRIPTION	PRICE
HZ-350	Haze machine with wireless transmitter	799.99
HZL-1	1-liter bottle haze liquid	16.13
HC-1	Optional timer remote	40.43

ANTARI HZ-400 PRO HAZER

The HZ-400 produces safe, dry, clean, and almost invisible haze that enhances the beams from any projected light, especially laser equipment. It has an internal, maintenance-free air compressor, a haze transfer mechanism, two haze nozzles and a specially-designed liquid tank. An added on-board DMX lets users control the unit with any DMX 512. HC-1 timer remote included.



ITEM	DESCRIPTION	PRICE
HZ-400	Pro Hazer, 2.5-liter tank, HC-1 timer remote included	1369.99
HCR-1	Wireless remote	40.43

ANTARI HZ-500 TOURING CLASS HAZER

This silent-operating on-stage hazer works perfectly with lighting and laser beams to produce the best atmospheric effects for any event. Its low liquid consumption rate makes it energy-efficient and more environmentally-friendly.



ITEM	DESCRIPTION	PRICE
HZ-500	Touring class hazer, 2.5-liter tank, on board DMX	1789.99
HZL-1	Non-toxic haze liquid (1 liter)	16.13

ANTARI DNG-200 LOW FOG MACHINE

Offers a complete ground fog effect solution in a self-compacted unit with wheels and handles to stand against tough transport. The fog generator is built-in to keep the solution compact. Antari's fog machines do not use carbon dioxide, and do not pollute the environment and are not harmful for human health. With its powerful compressor, 10-liter tank and efficient heat exchanger it's a true green machine. It is operator-friendly as there are no external controls to the machine. Simply plug the unit and place the 3M fog conducting hose (for remote dispersion) and operate it like a normal fog machine. Remote D-20 control module included.



ITEM	DESCRIPTION	PRICE
DNG-200	Low fog generator with control module	CALL
FLR-4	4liter bottle fog liquid	33.68
HC-1	Optional timer remote	40.43

ANTARI W-715 FOG JET

This fog machine has a new heating system that creates a sizeable output of 20 second bursts and increases heat preservation in order to reduce reheat time. The new fluid piping system removes any remaining fluid to provide a clear burst that doesn't produce excess fog. The W-715's 2 second jet mode outputs fog quickly via the unit's LCD control panel, DMX 512 signal, or through the W-1 wireless control system.



ITEM	DESCRIPTION	PRICE
W-715X	Fog machine	849.99
FLC-4	5 liter container of water-based fluid for W-715	24.23
C-300	Cleaning solution	24.99

ANTARI W-508 FOGGER

The cutting-edge wireless control system gives Antari W series foggers a simple setting and operation interface. The state-of-the-art 800W heater design upgrades the fog quality in terms of output at 3,000 cu.ft/min and energy efficiency that produces 20% more fog than most brands. There's even a fluid sensor that stops pumping automatically if the fluid runs dry to protect the pump from burning.



ITEM	DESCRIPTION	PRICE
W-508	800W fog machine with wireless control	239.99
FLR-4	4-liter fog fluid	33.68

ANTARI LIQUID CONTROL UNIT WITH ON BOARD DMX

With proper connection to compatible fog machines, this ground-based liquid supply unit offers control and convenience to anyone with a multi-fog machine installation. DMX or Z-8 (optional) remote gives control over automatic pumping of fog liquid to machines as needed for more efficient liquid usage. No more ladder climbing!



ITEM	DESCRIPTION	PRICE
LCU-1	Liquid Control Unit with On Board DMX	289.99

ANTARI AF-5 EFFECTS FAN

Antari's first special effects fan has 3 speeds that can fulfill different wind effect demands. This lets fog, haze, snow, and bubble machines to bring special effects to higher and farther places onstage and in venues. The AF-5's on-board DMX control gives the fan extra versatility and user control.



ITEM	DESCRIPTION	PRICE
AF-5H	Effects fan, 1 HP, fan speed control, on-board DMX module	1199.99

ANTARI ICE-101V

Avoid the difficulty of handling dry ice or the potential health hazards caused by dry ice "smoke". 10kg of ice cubes placed in the ice chamber creates a low-lying, ground-hugging fog which can last up to 12 hours (80 minutes with continuous output). When used without ice, it produces standard fog effects. Also offers a convenient manual/automatic drainage pump, timer remote and full on-board DMX control.



ITEM	DESCRIPTION	PRICE
ICE	High-powered fogger	849.99
FLR-4	Antari FLR (light fog liquid), 4 liters	33.68



Follow Us!

Let us show you exactly what to expect with our lighting design computer modeling and pre-visualization.

MORE THAN JUST FOG

FOG, HAZE, SNOW, WIND - *Command the Elements!*

F5 FAZER

- WATER BASED HAZE SYSTEM
- QUIET OPERATION
- EXTREMELY EFFICIENT FLUID CONSUMPTION
- CONTINUOUS OPERATION
- DMX OPERATION



Z-1520RGB

- POWERFUL 1500 WATT OPERATION
- OPERATES IN ANY POSITION
- BRIGHT RGB LEDs FOR COLORED FOG EFFECT
- DMX OPERATION
- BUILT-IN WIRELESS OPERATION



DNG-200

- POWERFUL, TOURING CLASS LOW FOG EFFECT
- 40,000 CU.FT./MIN GROUND FOG OUTPUT
- DMX OPERATION
- NO CO2 OR DRY ICE FOR EASY OPERATION



S-200X

- POWERFUL SIMULATED SNOW EFFECT
- CREATES 50% MORE SNOW THAN ITS' PREDECESSOR.
- DMX OR MANUAL OPERATION
- INSULATED FOR QUIET OPERATION
- INCLUDES WIRED VOLUME CONTROL REMOTE



AF-3

- POWERFUL CONTINUOUS HEAVY DUTY FAN
- SMOOTH 0-100% VARIABLE SPEED
- DMX OR MANUAL OPERATION
- SEALED SYSTEM FOR YEARS OF RELIABLE SERVICE
- OPTIONAL WIRELESS REMOTE OPERATION



C-300

KEEP YOUR FOG AND SNOW MACHINES RUNNING LIKE NEW.

A CLEANING SOLUTION THAT YOU CAN USE TO CLEAN AND MAINTAIN ANTARI FOG AND SNOW MACHINES. USING IT PROPERLY AND REGULARLY CAN GIVE YOU THE BEST PERFORMANCE AND THE LONGEST LIFETIME OF PRODUCTS.



800-356-5844
fullcompass.com

AUDIO



AMERICAN DJ FOG FURY 2000 PORTABLE FOG MACHINE

NEW!



- Convenient carry handle
- Fog output: 7000 (cubic feet/minute)
- Use only high-quality, water-based fog fluid
- Single yoke to mount on a wall or from trussing
- Includes On/Off wired remote control with 25-foot cable
- Automatic circuit cut-off to protect pump if fog fluid tank runs dry
- LED heating indicator system in tank: Red = Heating; Green = Ready to use; Flashing = Fog fluid tank is low
- ADJ's Electronic Thermo Sensing (ETS) technology maintains optimum heat levels with no warm-up times between fog blasts
- 1100W portable, high output Fog Machine with high-performance pump for optimum output, warm-up time: 8 minutes, 1200W maximum power consumption

ITEM	DESCRIPTION	PRICE
FOG-FURY-2000	1100W Portable high output fog machine	149.99

AMERICAN DJ BUBBLETRON BUBBLE MACHINE

With a high velocity, high output fan, this portable, easy-to-use machine creates hundreds of bubbles per minute and accepts most types of bubble liquids. Includes a wired on/off remote with 25 ft cable and is ideal for a wide variety of small- to medium-size applications. Also features an on/off switch on the rear of the unit and a durable plastic housing.



ITEM	DESCRIPTION	PRICE
BUBBLE-TRON	Bubble machine	99.99

AMERICAN DJ DYNO-FOG II MEDIUM DUTY FOG MACHINE

- 1,000W medium duty fogger
- 4,000 cubic feet per minute output
- 10' cable with controller
- 1-quart removable fog fluid container
- Hanging bracket
- Warm-up time: 5 minutes
- Fluid Consumption Rate: 10 Minutes per Liter at 100% output



ITEM	DESCRIPTION	PRICE
DYNO-FOG-II	Medium duty fogger	99.99



APOLLO DESIGN TECHNOLOGY SMART COLOR PRO SCROLLERS

Quiet operation, local or remote fan speed control and pre-installed Gel Shield are still standard, but the Pro Series adds a larger, rectangular front aperture which provides 10% more light throughput. Also new to the Pro Series are standard 18 color frames, 18% lighter weight and 25% lower power consumption. All models feature universal or adjustable mounting tabs, push button menu with LED display, 4-pin XLR in/out ports for daisy chaining and front-load gel strings. Other standard features include state-of-the-art digital circuitry with rotary DMX addressing, an automatic scrolling mode to continuously scroll or frame-by-frame step through each color at various speeds, and remote fan control.



ITEM	DESCRIPTION	PRICE
SC-SCROLL-5-PRO	For narrow beam fixtures, 5.25" apertures	494.05
SC-SCROLL-7-PRO	For all ellipsoidals and many wash fixtures, 7.25" apertures	494.05
SC-SCROLL-10-PRO	For 1000-2000W fixtures, 10" apertures	604.72

APOLLO DESIGN TECHNOLOGY MXR COLOR SCROLLER

A new twist on 2-string color mixing using subtractive color mixing to achieve desired hue and saturation. MXR's innovative color selection and frame sequence maximize useful colors. Its direct-drive, 4-motor system provides quiet and smooth color transition with low power consumption. Includes universal mounting plate.



ITEM	DESCRIPTION	PRICE
AC-SCROLL-MXR	MXR color mixer	789.87



APOLLO DESIGN TECHNOLOGY RIGHT ARM®

Adds 300° pan and 270° tilt capabilities to a wide range of static theatrical and studio lighting fixtures. Video cameras or projectors can be added to a lighting rig with minimal prep. Features 2-point integral balancing system for the use of front- or rear-heavy fixtures without counterweights or fixture modification. It offers a wide range of adjustment for fixture heights and widths without removing shutters or existing yokes. Also features user-defined pan and tilt range, an LCD screen, a 5-pin output, and a 4-pin output. Optional half coupler kit contains hardware for mounting your device to a pipe or truss.



ITEM	DESCRIPTION	PRICE
AC-RIGHT-ARM-3	Pan and tilt arm for static light fixtures, 40 lb. capacity	1149.73
AC-RA-COUPLER	Right Arm half coupler kit	64.68

APOLLO DESIGN TECHNOLOGY SMART MOVE® ROTATOR

Holds 1 or 2 'B'-size round gobos, secured by a heavy-duty retaining ring. Made of machined aluminum, the retaining ring is secured in place by 2 spring clips for easy adjustment and replacement. It is belt-driven for quiet operation and powered by a rugged 24V power supply (included). The rotator's black powder coat 18-gauge steel provides rigidity and durability. Variable speed range from 0 to 21 RPM plus rotary switches for easy setting to desired effect.



ITEM	DESCRIPTION	PRICE
SM-MOVE-000	Smart Move Rotator	364.10
SM-MOVE-DMX	DMX controlled version	465.00
AC-SP-75W	Power supply for DMX version	140.33

APOLLO DESIGN TECHNOLOGY SMART MOVE® VERTICAL

The Vertical features motion, time, and speed presets that create vertical movement of patterns or text. It can have 2 individual images on 1 gobo, allowing 1 image at a time to be placed in the focal path of the fixture. Additional effects can be created by placing another gobo in the fixture's gobo slot. Engineered for quiet, reliable operation and easy change out, the Smart Move Vertical holds 1 metal, 1 B/W, or 1 color glass gobo. It has variable vertical travel of 1/4" to 1 1/2", variable dwell time, and 17 pre-programmed effects.



ITEM	DESCRIPTION	PRICE
SM-MOVE-VRT	Smart Move Vertical	364.10
SM-MOVE-VRT-DMX	DMX controlled version	465.00
AC-SP-75W	Power supply for DMX version	140.33

APOLLO DESIGN TECHNOLOGY POWER SUPPLIES

Smart Power™ power supplies provide 24VDC to lighting accessories as well as control of indexing devices with a DMX signal.

- Smart Power 75W powers up to 1 MXR color mixer, 2 Smart Color scrollers, 5 Smart Move rotators, or a combination of these, (1) DMX 5-pin in, (1) DMX 5-pin out
- Smart Power 200W powers up to 8 Smart Color PROs, 6 Smart Colors, 13 Smart Moves, 13 EZ Irises or 5 MXRs, or a combination of these, (1) DMX 5-pin in, (1) DMX 5-pin out, (4) 4-pin XLR out, (4) 4-pin XLR returns
- Smart Power 400W powers up to 16 Smart Color PROs, 12 Smart Colors, 26 Smart Moves, 26 EZ Irises, 10 MXRs or a combination of these, (1) DMX 5-pin in, (1) DMX 5-pin out, (2) 4-pin XLR out, (2) 4-pin XLR returns
- Smart Power 600W powers up to 24 Smart Color PROs, 18 Smart Colors, 40 Smart Moves, 40 EZ Irises, 15 MXRs or a combination of these, (1) DMX 5-pin in, (1) DMX 5-pin out, (6) 4-pin XLR out, (6) 4-pin XLR returns



ITEM	DESCRIPTION	PRICE
AC-SP-75W	Smart Power 75W power supply	140.33
AC-SP-200W	Smart Power 200W power supply	580.45
AC-SP-400W	Smart Power 400W power supply	813.93
AC-SP-600W	Smart Power 600W power supply	1055.90



Follow Us!

Let us show you exactly what to expect with our lighting design computer modeling and pre-visualization.



SMART COLOR® PRO

Create beautiful colors on a robust scroller with a quiet smooth operation.



RIGHT ARM®

Make precise, smooth and quiet pan/tilt movement with static devices.



WRENCHES

Wrenches designed for the lighting professional

- Little Focus 3", 5" and 6"
- Apollo BTS 2-in-1 Wrench

For more information on all Apollo Design lighting products, contact your Full Compass sales representative today.

Cable



Gobos



Rotators



Power Supplies



Color Filter



Tape



AUDIO



Martin

MARTIN PROFESSIONAL JEM COMPACT HAZER PRO

Robust, small and lightweight this versatile haze machine is designed for the highly demanding professional market. Its ability to produce exceptional atmospheric haze effects in a short period of time (1-minute heat up time) while operating at low noise levels make it ideal for nearly any application from shows and events to theatre, TV studios, clubs, cruise ships, theme parks and more. Simple to use with on-board DMX 5-pin and ODTC system.



ITEM	DESCRIPTION	PRICE
JEM-COMPACT	Hazer, 2.5-liter, on-board DMX 5-pin	1236.56
C-PLUS-FLUID	4x2.5L fluid	44.81

MARTIN PROFESSIONAL MAGNUM 2500HZ HAZE MACHINE

The Magnum 2500HZ is a plug-and-play, easy-to-use hazer suitable for DJs, smaller venues, bars, and clubs. With a large fluid container and optional DMX, this hazer is ideal for installations.

- Continuous output with output and density level control
- Timer and output level remote control
- Integrated fan
- 900W heat exchanger
- 3.8-liter fluid capacity
- Fluid-out sensing



ITEM	DESCRIPTION	PRICE
MAGNUM-2500-HAZER	Haze machine	692.64
91612011	Optional DMX interface	108.82

MARTIN PROFESSIONAL MAGNUM-1800

The Magnum 1800 is a high-powered fogger suitable for any installation – from the largest to the smallest. Highly flexible, the 1800 is built sleek and rugged. Supplied with a timer remote control and featuring the same machine-saving overheat protection as Martin's larger machines.

- Onboard DMX
- Continuous output
- 580 m³/min fog output
- 9 minute heat-up time
- Optional flying kit
- 3.8-liter fluid capacity
- Different fluid options for different applications
- 1150 W (240V) / 1000W (110V) heat exchanger



ITEM	DESCRIPTION	PRICE
MAGNUM-1800	High-powered fogger	574.08
DJ-FLUID-5L	Regular DJ fluid	23.28
PROSMOKE-SUPER-5L	Pro Smoke Super (ZR Mix) fluid	26.10

rosco

ROSCO IPRO IMAGE PROJECTOR™

The iPro Image Projector™ projects images created from simple plastic slides. These iPro Slide cartridges are then attached to the back plate of the iPro and inserted into the iris slot of any one of several common luminaires. Even at 100% intensity, the iPro Slide will last from 15-50 hours with no fading or degradation. Choose any image from the Rosco iPro Slide Library (over 400 designs in 14 categories) or order a custom iPro Slide from your design. For last minute changes, an iPro Slide Kit is also available with easy instructions to design and print slides on-site.



ITEM	DESCRIPTION	PRICE
IMAGE-PRO-PROJECTOR	Image projector	304.93
HYBRID-TWO-FER	Power supply, allows you to connect the iPro and your light fixture into the same dimmer	56.80
IPRO-SLIDE-KIT	1-time slide kit which includes the slide mount and protective film to make an iPro slide with transparency film (not included) and your own printer	29.98
IPRO-SLIDE-LIBRARY	More than 400 images that can be made into an iPro slide, 24 hour turnaround	40.46
IPRO-CUSTOM-SLIDE	Turn your design into an iPro slide, 24 hour turnaround	40.46

rosco

NEW!



VAPOUR FOG MACHINE



VAPOUR PLUS FOG MACHINE



V HAZER



MINI V FOG MACHINE

ROSCO VAPOUR SERIES FOG MACHINES

These fog machines meet a variety of needs for theatre, feature film & television, theme parks and photographic studios. The Vapour, Vapour Plus, and Mini-V are compatible with Rosco's entire range of award-winning fog fluids. The Vapour, Vapour Plus, and V-Hazer all feature (2) standard control options: detachable remote for convenient, local control (with Multi-Link, for control of up to (4) daisy-chained units), and DMX. They also share various common-core, easily-swappable components to help simplify maintenance and repair. Reliability, ease of use and maintenance are additional hallmarks of this fog machine lineup.

ITEM	DESCRIPTION	PRICE
VAPOUR-FOG-MACHINE	120V Fog Machine	719.28
VAPOUR-PLUS-FOG-MCHN	120V Large Venue Fog Machine	863.28
V-HAZER	Haze Machine	1566.88
MINI-V-FOG-MACHINE	120V Compact Fog Machine	359.28

ROSCO I-CUE INTELLIGENT MIRROR

An intelligent mirror accessory designed to allow users of ellipsoidal spotlights to achieve many of the moving light effects traditionally available with automated fixtures. The unit is controlled via DMX 512 in 8-bit or 16-bit resolution. The moving mirror head offers smooth pan and tilt, as well as quick response re-positioning. The Rosco I-Cue ships ready to fit ETC Source Four, Altman Shakespeare, Strand SL, Selecon Pacific or any other light fixture with a 6.25" gel slot.



ITEM	DESCRIPTION	PRICE
I-CUE	Intelligent mirror	718.33
PSU-50	I-CUE power supply	140.98

ROSCO BELT DRIVE ROTATORS

Belt Drive FX units are designed for applications including theater, television and long running installations. They feature high-temperature silicon belts that are virtually silent at all speeds. The Belt Drives are versatile, fitting steel, litho glass or effect glass gobos. Also featured are reliable stepper motors for smooth drive even at the slowest speed.

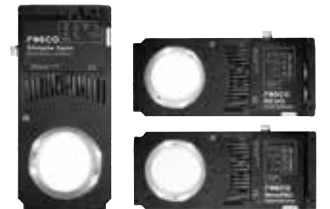

ITEM	DESCRIPTION	PRICE
SIMPLE-SPIN	Dual gobo rotator, single motor	353.85
REVO	Dual indexing rotator, two variable speed motors	443.42
REVO-PRO	Dual programmable rotator, DMX or stand-alone	532.99



Follow Us!

Let us show you exactly what to expect with our lighting design computer modeling and pre-visualization.

New Products For Your Next Production From



Vapour Series Fog & Haze Machines

Designed to meet the demands of theatrical productions, theme parks, film sets, concerts, photo shoots and safety training exercises, Rosco's new Vapour Series fog & haze machines offer the perfect balance of performance, durability and cost. The range consists of three fog machines: Mini-V, Vapour and Vapour Plus, and the V-Hazer for creating haze effects.



Miro Cube™ LED Fixtures

This range of remarkable luminaires produces a stunning amount of light from a compact 4" cube. Offering fixtures that include the WNC, a tunable color temperature white light, the 4C featuring quad-chip RGBW technology and the extra-powerful UV for stunning blacklight effects – Rosco's Miro Cube is the LED fixture of choice for theatres, nightclubs and broadcast studios.



GaffTac™ Tapes

Designed to meet the everyday challenges faced in theatre, filmmaking and photography, GaffTac tapes can be used anywhere a strong bond, no-residue, easy-tearing, tape is needed - such as: pipes & battens, stage & dance floors, road-cases, and console surfaces - just to name a few!

Rosco's new range of GaffTac tape products include: 2" Gaffer Tape, 2" Keying Tape, 1" Marking Tape and Spike Tape.



800-356-5844
fullcompass.com

AUDIO



ETC SOURCE FOUR MINI Everything you know and love about the Source Four scaled down and perfect for your venue. The Source Four Mini is a nearly exact replica of the Source Four, right down to the rotating barrel, shutters, gel frame and pattern holder, but with a 50W MR16 lamp. Available as a Portable or in Canopy Mount or Track Mount option. Black colors listed below, but white and custom colors available. Comes in 19°, 26°, 36° or 50° lens.



ITEM	DESCRIPTION	PRICE
4M19	Source Four Mini 19° fixture	247.80
4M26	Source Four Mini 26° fixture	247.80
4M36	Source Four Mini 36° fixture	247.80
4M50	Source Four Mini 50° fixture	247.80
4M19-I	Source Four Mini 19° fixture, canopy mount	289.80
4M26-I	Source Four Mini 26° fixture, canopy mount	289.80
4M36-I	Source Four Mini 36° fixture, canopy mount	264.60
4M50-I	Source Four Mini 50° fixture, canopy mount	289.80
4M19-T	Source Four Mini 19° fixture, track mount	373.80
4M26-T	Source Four Mini 26° fixture, track mount	373.80
4M36-T	Source Four Mini 36° fixture, track mount	373.80
4M50-T	Source Four Mini 50° fixture, track mount	373.80

Contact a Full Compass Sales Pro for additional info.



ETC SOURCE FOUR FRESNEL This fixture, using HPL lamp technology, combines the trademark controlled blending washlight and soft beam of a Fresnel with the quality of a Source Four. Also features socket and access door, a full-sized zoom knob, and a special ETC dichroic reflector design that enables a 750W lamp (can be substituted with lower wattage lamps) to equal the light output of a 1000W fresnel. Comes equipped with 36" three-wire Teflon® power leads with bare ends, and includes gel frame and c-clamp.

ITEM	DESCRIPTION	PRICE
FREST	7" Source Four Fresnel, black	331.80
FREST-1	7" Source Four Fresnel, white	407.40



ALTMAN 65Q 6" FRESNEL This short throw, all-purpose lighting device produces a soft edge beam which varies in diameter from 4.2' to 21' at a throw distance of 15'. Useful in theatre for acting area lighting where beam shaping is not required, or in television studios for key and backlighting. Includes color frame, UL listed up to 750W. Beam angle from 8.8 to 59 degrees. Compatible lamps are: BTL BTM BTN BTP BTR.



ITEM	PRICE
65Q	114.00

ALTMAN STEEL PAR CANS A rugged steel fixture for PAR lamps. Beam angle depends on the lamp used (lamp not included). Includes a steel color frame.



ITEM	DESCRIPTION	PRICE
PAR64-BLACK	UL rated for 1000W	78.00
PAR56	UL rated for 500W	74.25



LYCIAN STAGE LIGHTING MINI-ARC 1233 Compact 200W follow spot that produces a smooth, clean beam which broadens at the touch of a lever. Features a six color boomerang, dowser, gobo slot, fine focus & fully closing iris. No tools necessary for lamp changes and with no forced air cooling needed-no noise! Useful for schools, churches, clubs, small theatres and corporate events.



ITEM	DESCRIPTION	PRICE
1233	200W Mini-Arc follow spot	2324.40

ETC SOURCE FOUR PAR EA Source Four Par has rugged die-cast aluminum construction and acclaimed Source Four lighting technology. Changing beam angles is easy: Source Four Par comes with a set of four snap-in lenses that mount in a cool, rotating ring. And when you need a new lamp, just use your stock of Source Four HPLs (no need to carry a large inventory of expensive PAR64 lamps).



ITEM	DESCRIPTION	PRICE
S4PAR-EA	Source Four PAR-EA	169.40
400CC	C-clamp	13.50

ETC SOURCE FOUR Rated for up to 750W, the Source Four is perfect for punching through saturated colors and performing the longest throws. Ultra-efficient for more lumens per Watt. 5°, 10°, 14°, 19°, 26°, 36°, 50°, 70° and 90° field angles.

Supplied with C-clamp and color frame.

ITEM	DESCRIPTION	PRICE
S4-5	Source Four 5° fixture	592.90
S4-10	Source Four 10° fixture	477.40
S4-14	Source Four 14° fixture	462.00
S4-19	Source Four 19° fixture	338.80
S4-26	Source Four 26° fixture	338.80
S4-36	Source Four 36° fixture	338.80
S4-50	Source Four 50° fixture	338.80
S4-70	Source Four 70° fixture	462.00
S4-90	Source Four 90° fixture	462.00



ETC SOURCE FOUR JR A smaller-scale Source Four that uses the same technology for unsurpassed imaging and beam quality. Perfect for smaller theatres, churches, schools, and other applications where affordability and maximizing space is important.

ITEM	DESCRIPTION	PRICE
S4JR-26	26° lighting fixture	214.06
S4JR-36	36° lighting fixture	214.06
S4JR-50	50° lighting fixture	214.06
S4JR-25/50	50° zoom lighting fixture	267.96



LYCIAN STAGE LIGHTING SUPERARC 400 A bright light source in an economical package that is compact and useful in multiple applications. Produces a tight head spot at 150'. Uses a single lever continuous lens system with horizontal trim shutters and nichrome iris. Lamp changes without the need for tools.



ITEM	DESCRIPTION	PRICE
1266	400W standard throw follow spot	CALL

LYCIAN STAGE LIGHTING MIDGET MODEL 1206

A compact 1000W follow spotlight that is good for throws 40' to 120'. Extremely versatile with the ability to function as small spot to a large spot using the spread lens system. Also has an automatic self-canceling color boomerang and top-mounted iris and trim shutters, gobo slot and U-Ground power cable.



ITEM	DESCRIPTION	PRICE
1206	1000W Midget follow spotlight	1774.50

LYCIAN STAGE LIGHTING MIDGET HP MODEL 1209

The 1209 is a 575W follow spotlight that is good for throws 40' to 200'. Extremely versatile with a continuously variable beam that functions from small spot to large spot using the spread lens system. Comes with an automatic self-canceling color boomerang and nichrome heavy duty iris.



ITEM	DESCRIPTION	PRICE
1209	575W Midget HP follow spotlight	CALL



Follow Us!

Let us show you exactly what to expect with our lighting design computer modeling and pre-visualization.

SUPPORT FROM COAST TO COAST

FAST SHIPPING (from L.A. & Miami)
CAD DESIGN
GREAT SERVICE

See Listing
On Page 476!



FULL LINE OF CLAMPS,
BASEPLATES & ACCESSORIES



COMPLETE SELECTION OF
TRUSS. AVAILABLE IN
CUSTOM COLORS
(SPECIAL ORDER)



RIGGING SYSTEMS



GROUND SUPPORT &
CRANK STANDS



TRADESHOW EXHIBIT
DISPLAY SYSTEMS

**GLOBAL
TRUSS**
AMERICA
BUILDING THE FUTURE

DURATRUSSE

FULL COMPASS
PRO AUDIO VIDEO LIGHTING
MUSICAL INSTRUMENTS
800-356-5844
fullcompass.com

AUDIO



MUSIC



COMPUTER AV



LIGHTS



ACCESSORIES



GLOBAL TRUSS SQUARE TRUSS

- 11-7/16" overall width
- 3/4" diagonal bracing
- 0.008" tubing wall thickness
- 2" outer diameter of tubing
- 1 set of connecting hardware included



ITEM	DESCRIPTION	PRICE
SQ4109	1.64' square truss	146.30
SQ4110	3.28' square truss	186.20
SQ4110-75	2.46' square truss	159.60
SQ4111	4.92' square truss	246.05
SQ4111-1250	4.10' square truss	206.15
SQ4112	6.56' square truss	285.95
SQ4112-2.15	7.05' square truss	292.60
SQ4113	8.2' square trussw	332.50
SQ4114	9.84' square truss	365.75
SQ4115	11.48' square truss	418.95
SQ4116	13.12' square truss	465.50
SQ4117	14.76' square truss	505.40
SQ4118	16.4' square truss	551.95



SQ4133



COUPLER-CLAMP



PRO-CLAMP



TRIGGER-CLAMP

GLOBAL TRUSS CLAMPS AND ACCESSORIES

ITEM	DESCRIPTION	PRICE
PRO-SWIVEL-CLAMP	2" diameter swivel clamp	32.00
TRIGGER-CLAMP	Heavy-duty hook style clamp	24.00
PRO-CLAMP-ELATION	2" diameter aluminum fixture clamp	17.48
JR-CLAMP	1-1/3" diameter aluminum clamp	9.50
JR-SWIVEL-CLAMP	Light-duty swivel clamp	15.00
EYE-CLAMP	2" diameter aluminum clamp with eyebolt	22.50
COUPLER-CLAMP	2" diameter aluminum clamp with half coupler	21.00
COUPLER	Double-ended coupler for connection of truss sections	12.80
SQ4137	Base plate for square truss	60.80
TR4108	Base plate for triangular truss	45.60
SQ4121	2-way 90° corner block for square truss	231.00
SQ4123	2-way 135° corner block for square truss	259.35
SQ4126	3-way 90° corner block for square truss	305.90
SQ4129	3-way T-junction for square truss	305.90
SQ4133	4-way cross-junction for square truss	332.50
TR4086-U/D	2-way 45° corner for triangular truss, apex up or down	259.35
TR4088-U/D	2-way 90° corner for triangular truss, apex up or down	206.15
TR4088-I	2-way 90° corner for triangular truss, apex in	206.15
TR4089-U/D	2-way 120° corner for triangular truss, apex up or down	203.00
TR4090-U/D	2-way 135° corner for triangular truss, apex up or down	192.85
TR4093-U/L	3-way 90° corner for triangular truss, apex up	266.00
TR4093-U/R	3-way 90° corner for triangular truss, apex up	266.00
TR4096H-U/D	3-way horizontal T-junction for triangular truss, apex up or down	272.65
TR4100-U/D	4-way cross-junction for triangular truss, apex down	266.00



JAMES THOMAS ENGINEERING GENERAL PURPOSE TRUSS 12"x12" general purpose truss manufactured from 2" diameter x 0.125" wall aluminum tubing. Bolts are supplied for assembly of truss elements. This truss is ideal for conference, exhibition, and small venue work. By incorporating suitable sleeve blocks and towers, this truss can be used with JTE's Ground Support System.

ITEM	DESCRIPTION	PRICE
B0700	10' section	719.55
B0701	8' section	672.00
B0702	5' section	544.60
B0703	2'6" section	453.60
B4700	3 meter section	721.71
B4701	2.5 meter section	675.54
B4702	2 meter section	686.28
B4703	1.5 meter section	537.60
B4704	1 meter section	532.56
B4705	2-way corner block	439.60
B4705-A	3-way corner block	460.60
B4706	4-way corner block	502.60
B4707	6-way corner block	673.65



JAMES THOMAS ENGINEERING TAT AND MINI-TAT

The TAT (Thomas Audio Tower) is made of three 20.5" SuperTower sections and handles loads up to 2700 lbs. Its base can accept 2 additional sections of tower for additional stability in a traditional 'V' configuration. The MINI-TAT is three 12" SuperTower sections that supports loads up to 1500 lbs at 30' and 1850 lbs at 20'. Easily transported for load in and set up.

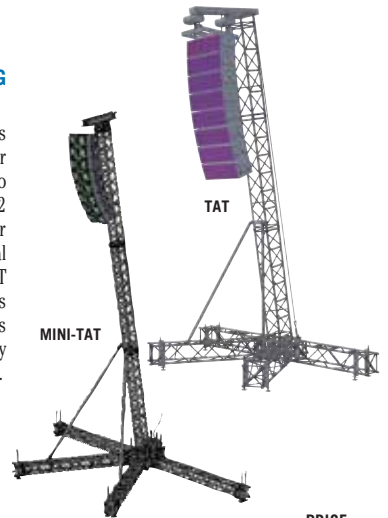

ITEM	DESCRIPTION	PRICE
TAT	20.5" SuperTower, aluminum, steel leveling jacks	CALL
MINI-TAT	12" SuperTower, aluminum, steel leveling jacks	CALL



MEGA TRUSS PICK



THE LIGHT SOURCE MEGA-TRUSS PICKS

Features two pockets with coupler-style aluminum pivoting links, 1/2" swivel bolts, and wing nuts. One top and one bottom rigging hole is for attaching truss to a shackle, motor, or chain hook. The picks fit 5/8" shackle and up and multi-hole versions (MH) are available, as well as some models in black (B, MHB). Capable of suspending one ton of truss load and additional one ton load under the truss. Global Mega-Truss Picks fit Global, Prolite, Milos and other trussing with 11-7/16" truss cord.

ITEM	DESCRIPTION	PRICE
MTP11.4375	11-7/16" Global Mega-Truss Pick	128.25
MTP12	12" Mega-Truss Pick	128.25
MTP16	16" Mega-Truss Pick	128.25
MTP18	18" Mega-Truss Pick	182.25
MTP20.5	20.5" Mega-Truss Pick	182.25
MTP24	24" Mega-Truss Pick	216.00
MTP30	30" Mega-Truss Pick	283.50

THE LIGHT SOURCE MEGA AIRWALL HANGERS

Fitting a variety of air wall tracks as well as Unistrut-style channels, these hangers have a continuous lip at the top that locks onto the load-bearing part of the track without causing damage. The panels of the hangers move outward and apart in order to engage the track. The center knurled wheel assembly expands the panels to lock the hanger to the track and the hangers' 1/8" hairpin locks the center wheel's position. The center opening above the 1.9" dia. pipe-like section is for clamping light fixtures, couplers, or attaching slings. Fits 0.8"-2.25" wide, 0.3"-3" deep slot sizes. 4" version is 500 lb rated and offers 8" of metal-to-metal contact with the track, 7" version is 750 lb rated and offers 14" of metal-to-metal contact.



4" MEGA AIR WALL HANGER

ITEM	DESCRIPTION	PRICE
MEM4	4" Mega Airwall Hanger	87.75
MEM7	7" Mega Airwall Hanger	128.25

STAGEMAKER STAGEMAKER RBC BEAM CLAMPS

- Capacities from 1 to 5 tons.
- Easily installed and adjusted by hand.
- Designed to minimize stress applied to beam.
- Built-in suspension bar allows for low headroom.
- Versatile jaws to adjust for use on I-Beams or Wide Flange beams.
- Provides temporary mounting point for hook mounted hoists or lever pullers.



ITEM	DESCRIPTION	PRICE
RBC-1000	1-ton beam clamp	72.34
RBC-2000	2-ton beam clamp	77.27
RBC-3000	3-ton beam clamp	126.60
RBC-5000	5-ton beam clamp	143.03



Follow Us!

Let us show you exactly what to expect with our lighting design computer modeling and pre-visualization.



ALTMAN FIXTURE ACCESSORIES

ITEM	DESCRIPTION	PRICE
510	C-clamp for 3/4" to 1-1/2" pipe	9.75
510-HD	Heavy-duty C-clamp for 1/2" to 2" pipe	18.75
SC-36-BK	Black safety cable with spring clip	5.25
6-CFB	Gel frame for 65Q/1KAF/360Q Series, S6-1535Z, S6-3055Z, PAR38, PAR56	3.75
8-CFB	Gel frame for 75Q Series, PAR64	6.00
360-PH	Gobo holder for 360Q, S6, S6C and 4.5 Series (Channel Style)	7.50
6-BD-4	4-door, 8-leaf: 65Q Series, 1KAF Series, PAR38, PAR56, UV250	48.75
8-BD-4	4-door, 8-leaf: 75Q, PAR64, PAR64-AL, PAR56/64-EA, UV-705, and SP Series	66.00
6-DN	Donut for 360Q Series	9.00



APOLLO DESIGN TECHNOLOGY EZ IRIS DMX



Allows designers to conveniently adjust the beam of light from many conventional ellipsoids. Designed for use in lighting fixtures up to 750W; including ETC S4, Altman Shakespeare, and Strand SL.

- Smooth actuation provides seamless aperture changes
- Gear-driven for positive operation
- Black powder coat 22-gauge steel for rigidity and durability
- Addressable from DMX 1-512

ITEM	DESCRIPTION	PRICE
AC-EZ-IRIS	EZ Iris DMX	407.48
AC-SP-75W	Single power supply for EZ Iris	140.33

APOLLO DESIGN TECHNOLOGY BTS WRENCH AND LITTLE FOCUS WRENCHES

This versatile BTS combination wrench has a wide-capacity adjustable crescent wrench on one end, with (3) sizes of closed-end wrenches (square 5/16" and 1/2"; Hex 3/4") built into the handle, providing easy access to industry-common bolt sizes to help eliminate carrying multiple wrenches. Little Focus stainless steel focusing wrenches come in 3", 5" and 6" models, offering similar utility with their industry-common bolt-size openings and wing nuts (except the 3" model), for quick clamp and fixture loosening/tightening, positioning, tilt lock, disassembly, and other tasks.



ITEM	DESCRIPTION	PRICE
AC-WRENCH	BTS adjustable/closed-end wrench	78.93
ACM-WRN-LF3001-F11	Little Focus 3, 3" focusing wrench	21.23
ACM-WRN-LF5001-F11	Little Focus 5, 5" focusing wrench	36.43
ACM-WRN-LF6001-F11	Little Focus 6, 6" focusing wrench	39.60

APOLLO DESIGN TECHNOLOGY PERMA PENNY

This 5" long aluminum truss protector slips onto light fixture C-clamps in order to prevent repeated damage from the clamps.



ITEM	DESCRIPTION	PRICE
OTH-PAP-100001-FIN-I	10-pack of Perma Penny truss protectors	31.11

APOLLO DESIGN TECHNOLOGY 4-PIN CABLES

High-quality, durable cable with 4-pin XLR connectors for related transfer of data and power from various lighting related accessory products such as rotators and scrollers.



ITEM	DESCRIPTION	PRICE
AC-4CABLE-3	4-pin accessory cable, 3'	27.33
AC-4CABLE-10	4-pin accessory cable, 10'	33.20
AC-4CABLE-25	4-pin accessory cable, 25'	45.74
AC-4CABLE-50	4-pin accessory cable, 50'	63.78
AC-4CABLE-100	4-pin accessory cable, 100'	96.83

APOLLO DESIGN TECHNOLOGY GOBO TOOLKIT

The purpose of the Gobo Toolkit is to train and educate. It introduces the basics of using gobos to create visual effects in general stage light applications. Kit contains (24) designed B-Round metal gobos, (1) Moon Natural B-Round B&W Glass Gobo, (1) Apollo SuperHolder™, (1) Creative Effects Guide, (1) instructional DVD and (1) resource CD.



ITEM	DESCRIPTION	PRICE
AC-GOBO-TK-800	B-size gobo kit, 24 metal gobos, 1 glass gobo, holder	238.63



FIXTURE NOT INCLUDED



APOLLO DESIGN TECHNOLOGY HOOP STAND

This elegant, simple wooden scissor stand allows fixtures to be positioned on the floor or table. It can be folded and left on fixtures for easier handling and faster set-up, or drilled and screwed directly to a floor surface for permanent mounting. It folds into itself to take up less space for storage.

ITEM	DESCRIPTION	PRICE
AC-HOOPSTAND-S	Wood lighting fixture stand/base	38.18

APOLLO DESIGN TECHNOLOGY C-CLAMPS

These c-clamps are durable, versatile and strong for hanging fixtures on a truss. The original Get-A-Grip™ comes in aluminum with galvanized hardware, while the newer Marine version comes in corrosion-resistant stainless steel hardware for wet conditions (not intended for direct salt-spray conditions). Both have a safe vertical working load limit (SVWL) of 600 lbs. Allow for a two week lead time on the marine version. The PipeDream™ is a mini-clamp version made from the same materials as the original Get-A-Grip, but is for lighter loads with a SVWL of 130 lbs. Available in either black or silver finish.



GET-A-GRIP

PIPE-DREAM

ITEM	DESCRIPTION	PRICE
AC-CLAMP-GG-S-B	Get-A-Grip aluminum c-clamp w/galvanized hardware, black	12.91
AC-CLAMP-GG-C-B	As above, 48 ct.	505.61
AC-CLAMP-GG-S-S	Get-A-Grip aluminum c-clamp w/galvanized hardware, silver	12.91
AC-CLAMP-GG-C-S	As above, 48 ct.	505.61
OTH-CLM-GAGMBS	Get-A-Grip Marine aluminum c-clamp w/ss hardware, black	19.68
OTH-CLM-GAGMBC	As above, 48 ct.	433.88
OTH-CLM-GAGMSS	Get-A-Grip Marine aluminum c-clamp w/ss hardware, silver	19.68
OTH-CLM-GAGMSC	As above, 48 ct.	433.88
AC-CLAMP-PD-S-B	PipeDream aluminum mini c-clamp w/galvanized hardware, black	7.52
AC-CLAMP-PD-C-B	As above, 24 ct.	144.70
AC-CLAMP-PD-S-S	PipeDream aluminum mini c-clamp w/galvanized hardware, silver	7.52
AC-CLAMP-PD-C-S	As above, 24 ct.	144.70

APOLLO DESIGN TECHNOLOGY GAF PAK TAPE™

Apollo tape is known for long life with no sticky residue, easily unwinds, and is simple to tear with just your fingers. With 50 oz. / in. adhesion for great grip, Apollo tape has a tensile strength of 44 lbs. / in. and is thick enough for the toughest applications. Apollo offers 4, 6 and 16-roll Gaf Pak Tape™.



Specify color: Black, White, Gray, Green, Yellow, Neon Yellow, Neon Green, Neon Orange or Neon Pink

Call your Sales Pro for ordering information

APOLLO DESIGN TECHNOLOGY TOUR JACKET

These protective covers are designed to be used in moving and storing both LED and conventional fixtures. Fixtures can be hung on pipes while covered and exterior labelling allows you to quickly identify the type and size of the fixture. Helps protect every part of your fixtures: onboard controls, shutter handles, lenses, etc.

TOUR JACKET



ITEM	DESCRIPTION	PRICE
AC-TOURJACKET-27	27.5" long light fixture protection sleeve	34.65

APOLLO DESIGN TECHNOLOGY LIGHT BLOCKING FOIL

A matte black aluminum foil that effectively blocks out unwanted light and reflections from fixtures or hardware. It is non-reflective, resistant to high heat, easy-to-use and easily conforms to hardware or fixtures. Each roll is packaged in a convenient, durable cardboard box.



ITEM	DESCRIPTION	PRICE
AC-FOIL-12X50	Light blocking foil, 12"x50' roll	25.85
AC-FOIL-24X25	Light blocking foil, 24"x25' roll	25.85

Shop fullcompass.com today!

For expert advice - call: 800-356-5844

M-F: 9:00-5:30 Central



- AUDIO
- VIDEO
- COMPUTER AV
- LIGHTS
- ACCESSORIES

CITY THEATRICAL INC

CITY THEATRICAL PROJECTOR DOWSER

The City Theatrical Projector Dowser is a DMX 512 controlled mechanical dowser for use with digital projectors. The Projector Dowser changes "video black" to a real blackout by positioning a large flag in front of the projector's lens. The flag is adjustable on the motor shaft to allow the Dowser to be placed above, below, or to either side of the projector. Travel of the flag is DMX adjustable within a range of 90 degrees and requires only a single channel of DMX. Powered via industry standard DMX/accessory power 4-pin XLR (scroller) cables. The Projector Dowser includes an accessory plate, velcro pad kit, allen key, and rubber feet. Power supply not included.



ITEM	DESCRIPTION	PRICE
4160	Projector dowser	483.00
2199	Power supply (up to two dwsers)	126.00

CITY THEATRICAL IMAGE MULTIPLEXER

- A multi-prism lighting accessory for theatrical ellipsoidals
- Drops into color frame slot (6-1/4")
- Multiplies image six times
- Use with static or moving gobos for stunning multi-image rotating effects



ITEM	DESCRIPTION	PRICE
1450	Image multiplexer	99.00

CITY THEATRICAL SOURCE FOUR FOLLOW SPOT ACCESSORIES

Use these accessories to turn your existing Source Four lighting fixtures into a fully functional follow spot. Fits all Source Four lens sizes.

ITEM	DESCRIPTION	PRICE
1500	Follow spot yoke for Source Four	604.17
1520	Follow spot yoke handle	29.30
1410	Drop-in boomerang for Source Four	326.34
1360	Follow spot handle for Source Four	43.47
2180	Drop-in iris for Source Four	90.00

CITY THEATRICAL STACKERS™ TAPERED TOP HATS

Tapered so they stack, but don't stick together. Lightweight aluminum construction and black flocked interior. Saves space in storage and transport.

ITEM	DESCRIPTION	PRICE
2840	6-1/4" full top hat	18.90
2842	6-1/4" short full top hat	18.90
2850	7-1/2" full top hat	21.74
2852	7-1/2" short full top hat	21.74
2860	10" full top hat	31.19
2862	10" short full top hat	31.19

CITY THEATRICAL SAFER SIDEARMS™

These sidearms transfer load from the lighting fixture back to the structural pipe. Safer Sidearm Junior augments a standard sidearm, while the others replace them. Steel Safer Sidearm utilizes 1-1/2" schedule 40 pipe.

ITEM	DESCRIPTION	PRICE
200	Safer original (uses 1/2" pipe)	82.22
202	Safer sidearm original with 18" of 1/2" pipe and 1 sliding tee	103.95
204	Safer sidearm original with 2" of 1/2" pipe and 2 sliding tees	120.02
220	Safer sidearm junior	24.57
210	Steel safer sidearm (uses 1-1/2" pipe)	109.62
211	1 1/2" pipe drilled for safer sidearm, priced per ft	13.10
290	Pipe end tail down (includes 6' of 1-1/2" pipe)	5.05



CITY THEATRICAL INC

CITY THEATRICAL LIGHTWRIGHT™ 5 LIGHTING PAPERWORK SOFTWARE

The quintessential tool for tracking all aspects of selecting, arranging, numbering, comparing, assigning and footnoting lighting paperwork.



- Lightwright/Vectorworks Data Exchange - an easy way to share data with Vectorworks Spotlight 2009
- Worksheet reconciliation compares and synchronizes show files
- Share files and worknotes via network and built-in email
- Completely rethought and enhanced worknotes
- Global search across all worksheet columns
- Complete history of all changes, with flexible rollback options
- Wheel design window for moving lights
- Color scroll design window
- Template pictures
- Standard colors choose list and color swatches on the worksheet
- Live instrument and accessory counts
- Automatic dimmer load balancing
- More than one show file can be open at a time
- 18 flexible user-definable columns

ITEM	DESCRIPTION	PRICE
3890	Personal Lightwright 5	453.60
3891	Institutional Lightwright 5	874.80
3892	Personal upgrade from LW4 to LW5	184.80
3893	Institutional upgrade from LW4 to LW5	457.80



GAM GAMTOOLS Provides reliable control and test tools that are indispensable to every lighting designer and electrician. The GAMCHEK 3-in-1 electrical tester cable tests monitors line continuity, show complete circuits, lamp and fixture continuity, power and polarity. GAMCHEK-JR easily tests cable integrity and monitors line continuity by checking dimmer output for power, polarity and ground.



ITEM	DESCRIPTION	PRICE
GAMCHEK	GT3100 3-in-1 Electrical Tester	167.31
GAMCHEK-JR	Stage Pin Cable Tester	48.51

GAM BLINKY AND MARK LITES

Save your head, protect your shins, find your way in the dark, hit your mark. These blinking or continuous LED lights will help! You can place them on a protrusion, stage edge, velcro on an overhead obstruction, use as a locator and guide light through a dark area or as a LED spot marker. The units will run continuously for months on two AA batteries.



ITEM	DESCRIPTION	PRICE
BLUE-BLINKY	Blue Blinky blinking LED light	13.81
RED-BLINKY	Red Blinky blinking LED light	13.81
BLUE-MARK-LITE	Blue Mark Lite continuous LED light	13.81
RED-MARK-LITE	Red Mark Lite continuous LED light	13.81

GAM BLACKWRAP MATTE BLACK ALUMINUM AND TAPE

BlackWrap, the original flexible matte black aluminum foil, is form-holding and heat resistant. It keeps its shape and resistance when wrapped around fixtures or hardware. Ideal for making a snoot or barndoors to control light. GAM's new adhesive has improved the BlackWrap™ Tape for easier removal and clean-up when striking.



ITEM	DESCRIPTION	PRICE
BLACKWRAP-2700	BlackWrap matte black aluminum foil, 12"x50"x.002"	20.72
BLACKWRAP-2710	As above, 24"x25"x.002"	20.72
BLACKWRAP-2715	As above, 36"x25"x.002"	41.43
BLACKWRAP-2770	As above, 48"x25"x.002"	58.45
BLACKWRAP-TAPE	BlackWrap adhesive tape, 2"x80' roll	58.45



Follow Us!

Let us show you exactly what to expect with our lighting design computer modeling and pre-visualization.



ELATION CAPTURE LIGHTING DESIGN SOFTWARE

Capture is a lighting design and documentation software that allows you to work in real-time with all elements of your design. Solo version allows for connection to any DMX source, real-time lighting design and visualization, working with layers and scenes, creation of custom gobos, customization of wheel and strings, import/export CSV files, 3D mouse support, full fixture library, LED panel visualization and free software upgrades. Basic version also includes the ability to create and print reports and plots. Extended version is the complete full version of Capture, offering the additional features of importing DWG, 3DS and OBJ files; exporting DWG files; video from local files; video from CFTP media servers; laser animation laser visualization; DMX controlled cameras; DMX controlled scenery; Kinesys K2 controlled scenery; and creation of Windows .exe movie presentations of a design.

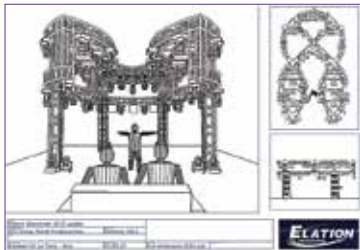

ITEM	DESCRIPTION	PRICE
CAPTURE-SOLO	Capture Lighting Design Software, Solo version	369.99
CAPTURE-BASIC	Capture Lighting Design Software, Basic version	1499.99
CAPTURE-EXTENDED	Capture Lighting Design Software, Extended version	2399.99

Martin

MARTIN PROFESSIONAL SHOWDESIGNER 6 PRO™ AND SHOWDESIGNER 6 LITE™ 3D LIGHTING PRE-VISUALIZATION SOFTWARE



Envision and develop lighting setups with this powerful software. The 3D engine technology provides real-time, photorealistic 3D visualization of lighting, video, animated scenery, truss, camera motion, and smoke effects. MSD 6 Pro features include Vectorworks file import/export, AutoCAD DXF and SketchUp file import, photometric calculation, fixture library covering most manufacturers and fixtures, real-time video input, and more. When ready, record the show as a video clip for review using any standard Windows video player. Then connect to a DMX console for convenient pre-programming. MSD 6 Lite™ focuses on more essential 3D pre-visualization and programming features, and is upgradeable.

ITEM	DESCRIPTION	PRICE
90756060	ShowDesigner 6 Pro 3D Lighting Visualizer/Programming Software with One-Key	CALL
39808040	As above, but with 5-year license, excludes One-Key	1892.54
39808041	ShowDesigner 6 Lite Offline Lighting Programming Software, 5-year license, excludes One-Key	790.83



ROSCO FLAMEX FLAME RETARDANT Each variety protects a specific type of scenic material. All types have been tested and certified according to the appropriate standards by NFPA, ANSI, and ASTM, with certificates of approval from the California Fire Marshall and NYC Fire Dept.



ITEM	DESCRIPTION	PRICE
FLAMEX-NF	For natural fiber, 1 gallon	40.03
FLAMEX-SF	For synthetic fiber, 1 gallon	62.63
FLAMEX-DF	For delicates, 1 gallon	62.63
FLAMEX-PC	For paper, 1 gallon	62.63
FLAMEX-WD	For wood, 1 gallon	62.63
FLAMEX-PA	Flamex paint additive, 1 case of (12) 8 oz. bottles	18.18



THE LIGHT SOURCE CLAMPS, CLAWS AND COUPLERS

The aircraft-grade aluminum Mega-Clamp is stronger and lighter than cast iron clamps and can hold loads nearing 2-1/2 tons hung from 1"-2" pipes. The Uni-Bolt fastens fixtures or pipes to 1-5/8" x 1-5/8" strut channels. Mega-Claws are for intelligent lighting fixtures and fit 1-1/2" to 2" pipe. Purlin clamps are for installing purlins, bar joints and I-beams up to 1" thick. Mega-Couplers fasten to 1-1/4" pipe up to 2" truss tube. The Mega-Baby is for hanging location-style lights on a studio grid (1"-2" pipe). The Mini-Baby is similar to the Mega-Baby but has no hairpin and is for 1-1/4"-1-1/2" pipe.



MEGA CLAW BLACK

ITEM	DESCRIPTION	PRICE
MAB	Mega-Clamp, black anodized finish	10.13
MAM	Mega-Clamp, aluminum finish	10.13
MAW	Mega-Clamp, white powder finish	14.18
UB2B	Uni-Bolt for strut channels, black anodized finish	17.55
MWB	Mega-Claw, black anodized finish	29.70
MWM	Mega-Claw, aluminum finish	26.33
PCM1/2	Purlin Clamp with 1/2" fasteners	9.45
PCM3/8	Purlin Clamp with 3/8" fasteners	8.10
MLB	Mega-Coupler, black anodized finish	20.93
MLBBP	Mega-Coupler with 5/8" baby pin, black anodized finish	32.40
MLM	Mega-Coupler, aluminum finish	18.23
MLMBP	Mega-Coupler with 5/8" baby pin, aluminum finish	29.70
MBB	Mega-Baby clamp with 5/8" pin and 1/8" hairpin, black anodized finish	25.65
MNBB	Mini-Baby clamp with 5/8" pin, black anodized finish	17.89

THE LIGHT SOURCE TOOLS The Mega-Combo pocket wrench fits onto a keychain and has 1/2" and 5/16" hex heads and square head bolts. The Mongo Wrench fastens everything that a Mega-Combo wrench can, as well as Mega-Coupler nuts and other coupler wing nuts.



ITEM	DESCRIPTION	PRICE
MCM	Mega-Combo wrench, aluminum finish	7.43
MCM-BLACK	Mega-Combo wrench, black anodized finish	7.43
MLT	Mongo wrench, aluminum finish	7.43

STAGEJUNK

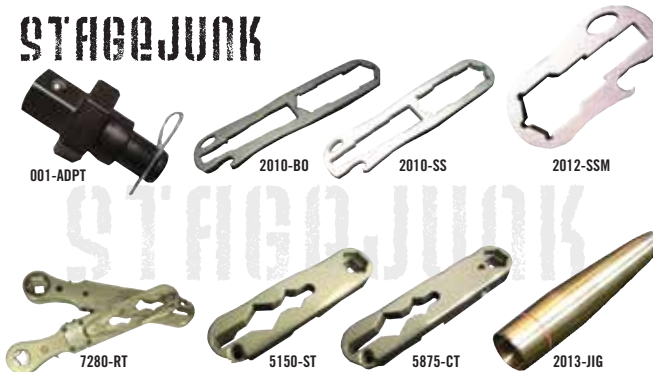

STAGEJUNK FOCUS TOOLS These all-in-one tools are designed for stagehands and roadies who rig gear in theatres or on location. They provide helpful grip and leverage when working with standard and metric hardware connections on c-clamps, lighting fixtures, wing nuts, barrel nuts, handles and road case latches. These handy units also relieve stress and strain on hands and wrists and cut down on burns when adjusting or breaking down lighting. There's even a built-in bottle opener for the end of the gig! The Ratcheting Ultimate Focus Tool allows access to hard to reach connections that require extra torqueing and the optional 3/8" socket adapter adds to the versatility of this tool. The XLR resizing jig works for AMX, DMX and Ethercon connectors and allows you to re-round the connector by inserting the job and pushing or tapping on it gently with a hard plastic or rubber hammer.

ITEM	DESCRIPTION	PRICE
2010-BO	Flat Focus Tool, black	18.90
2010-SS	As above, stainless	18.90
2012-SSM	Mini Flat Focus Tool, stainless	9.00
2013-JIG	XLR resizing jig	38.40
375-SB	Shackle Buster, stainless	23.80
5150-ST	Standard Focus Tool, stainless	39.00
5875-CT	Ultimate Focus Tool, stainless	72.80
7280-RT	Ratcheting Ultimate Focus Tool	97.20
001-ADPT	Socket adapter for Ratcheting Ultimate Focus Tool	14.00

Shop fullcompass.com today!

For expert advice - call: 800-356-5844

M-F: 9:00-5:30 Central



AUDIO



MUSIC



COMPUTER AV



VIDEO



LIGHTS



ACCESSORIES



AUDIO



CITY THEATRICAL BEAM BENDER

- Attaches easily to any Source Four™, SL, Shakespeare or Selecon Pacific ellipsoidal for flexibility in fixture placement
- Ideal for shooting around scenery or other obstructions
- Adjustable mirror for controlling angle and spread of beam
- Especially useful for dance designers needing maximum light output at floor level

ITEM	DESCRIPTION	PRICE
1400	Beam bender	96.00



CITY THEATRICAL TRACK TAMERS

Track Tamers separate the lockdown of the track from the lockdown of the lighting fixture, making it easier and faster to hang equipment off Unistrut. Each have a rated working load limit of 500 lbs.

ITEM	DESCRIPTION	PRICE
520	Track Tamer with hex nut	26.46
520M	Track Tamer with hex nut (metric)	28.23
521	Track Tamer with knob	37.92
521M	Track Tamer with knob (metric)	39.69
523	Track Tamer with aluminum split coupler	80.27
525	Track Tamer with galvanized clamp and hex nut	52.92
530	Track Tamer with hex nut and 5/8" male pin	39.69
531	Track Tamer with knob and 5/8" male pin	51.15

ETC FIXTURE ACCESSORIES

ITEM	DESCRIPTION	PRICE
400PH-A	Pattern holder for 'A' size patterns	7.34
400PH-B	Pattern holder for 'B' size patterns	7.34
400PH-G	Pattern holder for 'B' size glass patterns	10.89
400RS	Drop-in iris	117.60
400DN	Donut	6.17
400GE	Gel extender	26.88
400TH	Top hat	18.48
400HH	Half hat	18.48
400CC	C-clamp	13.50
400SC	32" Safety cable	8.55

FOG AND HAZE MACHINE FLUIDS

ITEM	DESCRIPTION	PRICE
American DJ		
F-UNSCENT/G	Unscented water fog juice, 1 gallon	29.99
KOOL-FOG	Fog for low-lying machine, 1 gallon	24.99

Look Solutions

UN-3151	Haze fluid	53.90
UN-3152	Haze fluid	220.50
VI-3501	Fog fluid	53.90
VI-3502	Fog fluid	235.20
VI-3505	Fog fluid	49.00
VI-3509	Fog fluid	56.35

Martin

PROSMOKE-SUPER-9.5L	Fog fluid, 2.5 gallon	47.85
I-FOG	Fog fluid, 1 gallon	34.16
DJ-FLUID-5L	Fog fluid, 1 gallon	23.28
PROHAZE-MINI	ProHaze, 1 gallon	14.36

Rosco

08200-0034	Std. fluid, 1 liter	16.95
09000-0034	Stage/studio, 1 liter	16.65
09000-0135	Stage/studio, 4 liter	58.90
08500-0034	Light fluid, 1 liter	13.70
08500-0135	Light fluid, 1 liter	47.65
08600-0034	Clear fluid, 1 liter	16.65
08400-0034	Haze fluid	22.10

VIDEO



LIGHTS



ACCESSORIES



ROSCO ROSCOLUX A durable color filter available in 119 colors. Includes the entire SuperGel line plus additional colors and diffusions not available in polycarbonate plastic.

ITEM	PRICE
SHEETS: 20"x24"	7.70
ROLLS: 24"x25'	110.11

ROSCO ROSCOLUX DIFFUSION A range of filters in the stable Roscolux base, designed to alter the shadow characteristics of the beam shape of light.

ITEM	PRICE
SHEETS: 20"x24"	7.77

ROSCO ROSCOLUX TUNGSTEN CONVERSION FILTERS A range of blue filters that raise color temperature as needed. Although typically used on tungsten-halogen sources to balance with daylight, the range offers a multitude of technical and aesthetic color correction possibilities. The material is deep-dyed for heat stability and superior color transmission. Rolls are 48" x 25' (122cm x 7.6m).

ITEM	PRICE
SHEETS: 20"x24"	7.77
ROLLS: 48"x25'	181.30

GEL KITS DESIGNED EXCLUSIVELY FOR FULL COMPASS CUSTOMERS

FULL COMPASS VIDEO GEL KIT

Essential color correction and diffusion filters ideal for Three-Point lighting setups. Assorted 10" x 12" Cinegel filters for color correction, color effects and diffusion. Filter types include Blue and Amber correction filters to balance various combinations of light sources, Plusgreen filter for balancing daylight and other secondary sources with fluorescents, Color Effects filters to enhance light, and diffusion materials for dispersing and softening light. These gels have been hand selected by Full Compass lighting specialists to be a flexible package for the still photographer, filmmaker, or video professional. Includes 48 gels.

ITEM	DESCRIPTION	PRICE
1023FCSGSKIT	Full Compass Starter Gel Kit	17.06
1010FCVGSKIT	Full Compass Video Gel Kit	71.76



ROSCO GAFFTAC GAFFERS' TAPE

This gaffer's tape is non-reflective, tears easily, leaves no residue, and adheres to a variety of surfaces – stage floors, walls, road cases, stands, fabrics, and more Available in a variety of color options.



ITEM	DESCRIPTION	PRICE
GAFFTAC-1/2"	55 yard roll of 1/2" Gaffer Tape	6.69
GAFFTAC-1"	55 yard roll of 1" Gaffer Tape	9.73
GAFFTAC-2"	55 yard roll of 2" Gaffer Tape	19.50



ROSE BRAND CABLE PATH Designed specifically for taping over audio, video and electrical cables, Cable Path's adhesive is located only on the outer edges of the tape. Cables are held in the non-sticky center channel, leaving them free of gummy adhesive. Cable Path's pressure-sensitive adhesive allows for easy removal from carpet and other surfaces and may be repositioned several times without losing integrity. Hand tearable and puncture resistant. Available in black or black/yellow safety stripe.



ITEM	WIDTH	LENGTH	COLOR	1-2	3-5	6-11	12
CABLEPATH-4"-BLK	4"	30 yards	Black	24.12	23.19	22.26	21.33
CABLEPATH-4"-BLK/YLW	4"	30 yards	Black/Yellow Stripe	24.12	23.19	22.26	21.33
CABLEPATH-6"-BLK	6"	30 yards	Black	37.90	36.44	34.98	33.52
CABLEPATH-6"-BLK/YLW	6"	30 yards	Black/Yellow Stripe	34.13	32.81	31.50	30.19

GAFFERS' TAPE

ITEM	WIDTH	LENGTH	1-2	3-5	6-11	12
GAFFERS-1"	1"	55 yards	9.06	8.64	8.21	7.93
GAFFERS-2"	2"	55 yards	15.34	14.97	14.23	13.74
GAFFERS-3"	3"	55 yards	23.93	23.01	22.09	21.17

Specify color: Black, Brown, Lt. Blue, Dk. Blue, Lt. Grey, Lt. Green, Green, Red, White, Yellow, Purple, Burgundy, Teal

MISCELLANEOUS TAPE

ITEM	WIDTH	LENGTH	1-2	3-5	6-11	12
CLOTH-SPIKE-TAPE	1/2"	50 yards	7.31	6.88	6.45	6.02
CONSOLE-3/4"TAPE-WHT	3/4"	55 yards	8.06	6.45	5.64	4.84
CONSOLE-1"TAPE-WHITE	1"	55 yards	9.88	7.90	6.92	5.93
GLOWTAPE-1/2"	1/2"	10 yards	12.50	10.00	8.75	7.50
GLOWTAPE	1"	10 yards	18.00	14.40	12.60	10.80



Follow Us!

Let us show you exactly what to expect with our lighting design computer modeling and pre-visualization.

Littlite®

For over 30 years Littlite has been the task light of choice for music industry professionals all over the world. Littlite gooseneck lights can be found on stage, backstage, side stage and front of house. We offer over 300 configurations and our lights are compatible with all major audio and lighting consoles. Littlite offers a solution for any task lighting challenge.

Insist on the original, Littlite!

LED, Halogen, Incandescent ✦ Made in the USA ✦ Limited Lifetime Warranty
✦ Energy Efficient, Low Voltage Operation ✦ Dozens of Mounting Options

See Listing
On Page 482!



the Original the Original the Original the Original the Original

Littlite®
Gooseneck Task Lamps & Accessories

FULL COMPASS
PRO AUDIO VIDEO LIGHTING
MUSICAL INSTRUMENTS

800-356-5844
fullcompass.com

AUDIO



MUSIC



VIDEO



LIGHTS



ACCESSORIES



Littlite

LITTLITE L-SERIES SETS

L-Series lighting sets come complete and ready for surface mounting. Available in 6", 12", or 18" lengths with bulb, mounting base, dimmer, 6' cord, 2-piece snap mount, screws for permanent mounting and a wall plug-in transformer. 'A' versions are available without the transformer and can be powered by any available 12V supply.



THE L-1 features detachable gooseneck swivel connector at the base and gooseneck storage clips. The lamp has a low-intensity incandescent bulb in tubular hood.

THE L-2 features a permanently attached gooseneck with a low-intensity incandescent bulb in an unobtrusive tubular hood.

THE L-3 features a permanently attached gooseneck with a high-intensity tungsten-halogen bulb in a stylish finned hood.

THE L-4 features a detachable, gooseneck swivel connector at the base and gooseneck storage clips. Lamp has a high-intensity, tungsten-halogen bulb in a finned hood.

LITTLITE COMPLETE KITS

ITEM	DESCRIPTION	PRICE
L1/12	12" detachable, dimmer, transformer, base	66.75
L1/12A	As above, without transformer	55.40
L1/18	18" detachable, dimmer, transformer, base	66.75
L1/18A	As above, without transformer	55.40
L2/6	6" base mounted, dimmer, transformer	55.40
L2/12	12" base mounted, dimmer, transformer	55.40
L2/12A	As above, without transformer	44.15
L2/18	18" base mounted, dimmer, transformer	55.40
L2/18A	As above, without transformer	44.15
L3/6	6" high-intensity, base, dimmer, transformer	66.75
L3/12	12" high-intensity, base, dimmer, transformer	66.75
L3/12A	As above, without transformer	55.40
L3/18	18" high-intensity, base, dimmer, transformer	66.75
L3/18A	As above, without transformer	55.40
L4/12	12" high-intensity, detachable, dimmer, transformer	78.00
L4/18	18" high-intensity, detachable, dimmer, transformer	78.00

LITTLITE INDIVIDUAL LIGHTS

ITEM	DESCRIPTION	PRICE
6G	6" with BNC connector	32.30
6P	6" with 3/8" connector	27.15
6X	6" detachable with XLR connector	39.15
12G	12" with BNC connector	32.30
12G-HI	12" BNC high-intensity	43.60
12P	12" with 3/8" threaded end	27.15
12X	12" detachable with XLR connector	39.15
12X-4	12" with 4-pin XLR	53.85
12X-HI	12" 3-pin XLR high-intensity	50.55
12X-HI-4	12" high intensity 4-pin angle lamp	64.70
12XR-HI	12" high intensity 3-pin angle lamp	63.20
18P	18" with 3/8" threaded end	27.15
18G	18" with BNC connector	32.30
18G-HI	18" BNC high intensity	43.60
18X	18" detachable with XLR connector	39.15
18X-4	18" with 4-pin XLR	53.85
18X-HI	18" 3-pin XLR high intensity	50.55
18X-HI-4	18" 4-pin XLR high intensity	64.70
18XR	18" detachable angle lamp	52.00
18XR-HI-4	18" 4-pin XLR right angle	78.30

LITTLITE ACCESSORIES

ITEM	DESCRIPTION	PRICE
1815	Standard bulb 12V 230ma 2.4W	3.25
CF	Color filter set	4.15
CL	Adjustable clip for 'L' models	15.25
DM	Dimmer, 3/8" mounting	12.40
GPK	Dimmer base for BNC lamps	41.10
HH	High hood replacement	8.50
HTC	High tension clamp	10.60
MB	Magnetic base	16.50
MP	Mounting plate with 3/8" hole	5.30
O-KIT	O-ring kit	3.25
PS	BNC panel socket	2.60
Q5	High-intensity bulb 12V 280ma 5W	9.00
SC	Storage clips, pair	3.80
SM	Snap mount for 'L' models	4.95
CWB	Weighted base	26.80

MIGHTY BRIGHT.

MIGHTY BRIGHT GEARHEAD LED HEADLAMP

Provides hands-free, targeted LED illumination, casting a 75 lumen beam of white LED light up to 50 meters. Features high, and low brightness settings and an adjustable 24" headband.



ITEM	DESCRIPTION	PRICE
90515	GearHead LED headlamp in blue	19.99
90516	Same as above, but in black	19.99

MIGHTY BRIGHT HAMMERHEAD LED MUSIC LIGHT

The powerful HammerHead LED Music Light's eye-catching design will make you- and your music- the star of the show. Its six powerful, bright white LEDs last 100,000 hours, and its flexible gooseneck illuminates every note. Take the portable HammerHead with you - whether you're DJing, playing, or singing - and make every performance perfect.



ITEM	DESCRIPTION	PRICE
54810	LED music light, 28 lumens, gig bag included	19.99

MIGHTY BRIGHT MUSICIAN'S LIGHTS XTRAFLEX DUET™ DUET2 LED MUSIC LIGHT

These dual super LED lights with two adjustable goosenecks can light two pages at once. Clips easily to almost anything and offers 20 hrs of continuous use. The Duet2 offers 4 different light level options.



ITEM	DESCRIPTION	PRICE
50810	XtraFlex Duet dual LED gooseneck lights, black	19.99
51810	Duet2 dual LED gooseneck lights, black	31.99
80910	Light cradle/stand-alone base for XtraFlex lights, Duet lights, black	5.59

XTRAFLEX™ SUPER LED Super LED can be positioned in any direction. Special lens spreads light evenly with no hot spots.

ITEM	DESCRIPTION	PRICE
50412	Silver	11.99
50410	Black	11.99

MIGHTY BRIGHT LUX SPOTLIGHT LED TASK LIGHTS

This classic, timeless, petite design can accentuate any room's aesthetic, and is ideal for a crowded desk, end-table, or nearly any small space needing extra targeted light. Flicker-free, efficient LEDs yielding an estimated 50,000 hours of continuous life while emitting 275 lumens of warm and 3200 Kelvin white light. With an adjustable gooseneck, 180° swiveling head and steel construction ensuring an eco-friendly, functional usage for years to come.



ITEM	DESCRIPTION	PRICE
74010	LUX Spotlight LED Task Light, Black Satin	31.99
74012	As above, in Brushed Nickel	31.99

MIGHTY BRIGHT LUX DOME LED TASK LIGHTS

With its classic, timeless design, this free-standing adjustable light fits any décor. Flicker-free, efficient LEDs yielding an estimated 50,000 hours of continuous life while emitting 250 lumens of pleasant 4000 Kelvin white light. With height adjust and 360° swiveling head this fixture is eco-friendly and utilitarian. Steel construction means durability. Available in (4) colors.



ITEM	DESCRIPTION	PRICE
72010	LUX Dome LED Task Light, Black Satin	63.99
72011	As above, in Turquoise	63.99
72012	As above, in Brushed Nickel	63.99
72014	As above, in Chartreuse Green	63.99

ORCHESTRA LIGHT Features 9 bright white LEDs, with 2 brightness levels and a flexible gooseneck. Up to 20 hours of battery life with 3 AA batteries. Stable free-standing base and broad padded clip.



ITEM	DESCRIPTION	PRICE
53510	Black with padded bag	59.99

PEDAL BOARD LIGHT Includes 2 red LEDs for subdued on-stage lighting and 2 white LEDs for set list reading, dual flexible arms, and extra-strength clips.

ITEM	DESCRIPTION	PRICE
52010	Pedal board light, black	71.71



Follow Us!

Let us show you exactly what to expect with our lighting design computer modeling and pre-visualization.