

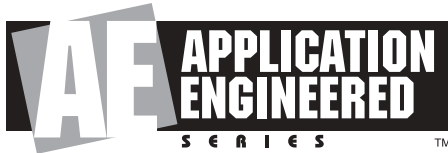

AC2212/95 Compact 2-Way Loudspeaker with 1 x 12" LF



Key Features:

- ▶ 90° x 50° Coverage.
- ▶ PT™ Progressive Transition™ Waveguide for good pattern control with low distortion.
- ▶ Bi-Amp/Passive Switchable.
- ▶ Optional U-Bracket for easy installation.
- ▶ Optional planar array frame kit (see AE Series Bracket Guide).

Applications:

- ▶ Lecture halls
- ▶ Houses of worship
- ▶ Corporate learning centers
- ▶ Small performing arts facilities
- ▶ Theatrical sound design
- ▶ Auditoriums
- ▶ Sports facilities
- ▶ Themed entertainment venues
- ▶ Delay/fill locations of larger systems

AC2212/95 is a compact 2-way full-range loudspeaker system comprised of one 300 mm (12 in) low frequency driver and one 25 mm (1 in) voice-coil compression driver. The PT Progressive Transition waveguide provides 90° by 50° coverage. High-slope passive crossovers minimize band overlap and well-controlled off-axis response enhances arrayability.

The cabinet is fitted with M10 threaded suspension points. Optional U-bracket, as well as pre-engineered array bracketry is available for easy installation. Four threaded inserts located on back of the enclosure allow attachment of an Omnimount™ or similar mounting bracket.

AC2212/95 is part of JBL's AE Application Engineered Series, a versatile family of loudspeakers for a wide variety of fixed installation applications.



Specifications:

System:	
Frequency Range ¹ (-10 dB):	50 Hz – 19 kHz
Frequency Response ¹ (±3 dB):	55 Hz – 17 kHz
Coverage Pattern:	90° x 50°
Directivity Factor (Q):	8.9
Directivity Index (DI):	9.5 dB
Crossover Modes:	Bi-amp/Passive switchable
Passive Crossover Slopes:	3rd order (18 dB/oct) Butterworth HP & LP, 1700 Hz
Transducer Power Rating (AES):	LF: 300 W (1100 W peak), 2 hrs 250 W (1000 W peak), 100 hrs HF: 30 W (120 W peak), 2 hrs
Long-Term System Power Rating (IEC):	Passive mode: 250 W (1000 W peak), 100 hrs
Maximum SPL ² :	Bi-amp mode: LF: 120 dB-SPL cont avg (126 dB peak) HF: 127 dB-SPL cont avg (133 dB peak) Passive mode: 120 dB-SPL cont avg (126 dB peak)
System Sensitivity ³ (1W @ 1m):	Passive mode: 95 dB SPL
Transducers:	
<u>Low Frequency Driver:</u>	1 x JBL M112-8 300 mm (12 in) driver with 63 mm (2.5 in) voice coil
Nominal Impedance:	8 ohms
Sensitivity ⁴ (1W @ 1m, within operational band):	95 dB SPL
<u>High Frequency Driver:</u>	JBL 2412H compression driver, 25 mm (1 in) voice coil
Nominal Impedance:	8 ohms
Sensitivity (1W @ 1m):	112 dB SPL
<u>Waveguide:</u>	PT-F95HF-1
Physical:	
Enclosure:	Trapezoidal with 15 degree side angles, 16 mm (5/8 in) exterior grade 11-ply Finnish birch plywood
Suspension Attachment:	15 points (4 top, 4 bottom, 2 each side, 3 rear), M10 threaded hardware. 4 x M5 on rear for Omnimount™ 100 Series
Finish:	Black DuraFlex™ finish. White available upon request.
Grille:	Powder coated 14 gauge perforated steel, with acoustically transparent black foam backing.
Input Connector:	NL4 Neutrik Speakon® and CE-compliant covered barrier strip terminals. Barrier terminals accept up to 5.2 sq mm (10 AWG) wire or max width 9 mm (.375 in) spade lugs. Speakon in parallel with barrier strip for loop-through.
Environmental Specifications:	Mil-Std 810; IP-x3 per IEC529.
Dimensions (H x W x D):	548 x 355 x 352 mm (21.6 x 14.0 x 13.9 in)
Net Weight:	17.3 kg (38 lb)
Optional Accessories:	M10 x 35 mm forged shoulder eyebolts with washers U-Bracket MTU-4 Optional planar array frame kit. See AE Series Bracket Guide

¹Bi-amp mode, with recommended active tuning.

²Resultant engineered acoustical response of crossover network and components.

³AES standard, one decade pink noise with 6 dB crest factor within device's operational band, free air. Standard AES 2 hr rating plus long-term 100 hr rating are specified for low-frequency transducers.

⁴IEC standard, full bandwidth pink noise with 6 dB crest factor, 100 hours.

⁵Calculated based on power rating and sensitivity, exclusive of power compression.

⁶Anechoic sensitivity in free field, no additional sensitivity gain from boundary loading.

JBL continually engages in research related to product improvement. Changes introduced into existing products without notice are an expression of that philosophy.

▶ AC2212/95 Compact 2-Way Loudspeaker with 1 x 12" LF

Beamwidth

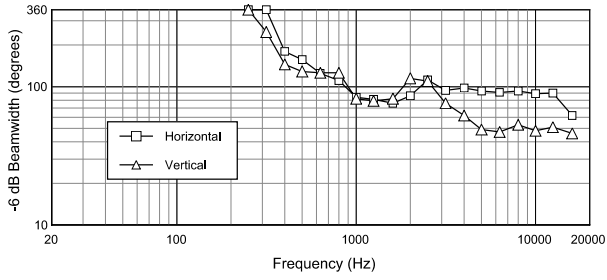

Horizontal Off-Axis Frequency Response

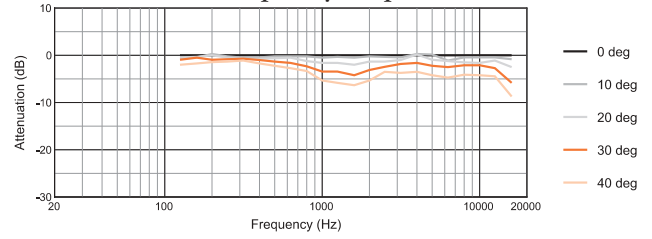

Directivity Index, Q

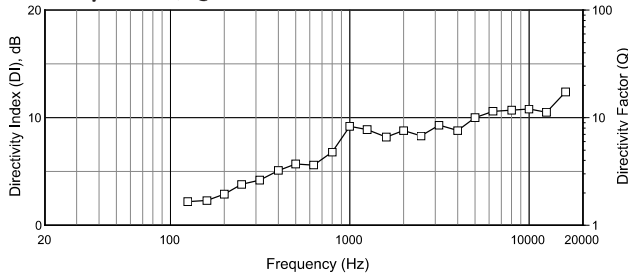

Vertical Up Off-Axis Frequency Response

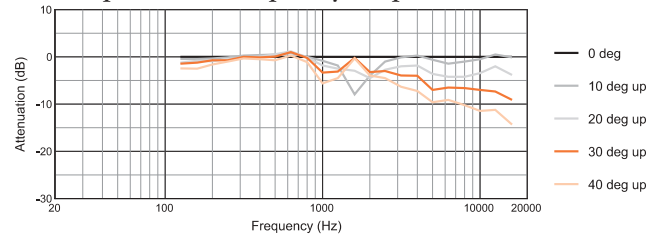

Dimensions

Dimensions in mm (in)

For more detailed dimensional information, refer to Application Data Sheet

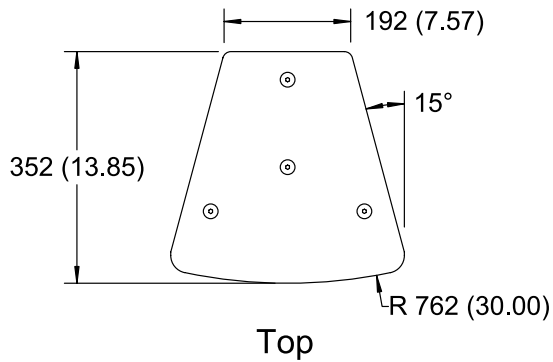

Vertical Down Off-Axis Frequency Response

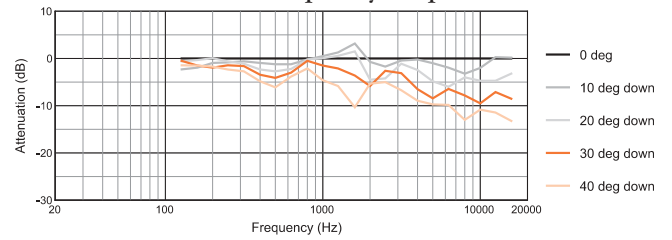

Measurements obtained in full passive crossover mode with no signal processing. Graphs are from unaltered measured data.

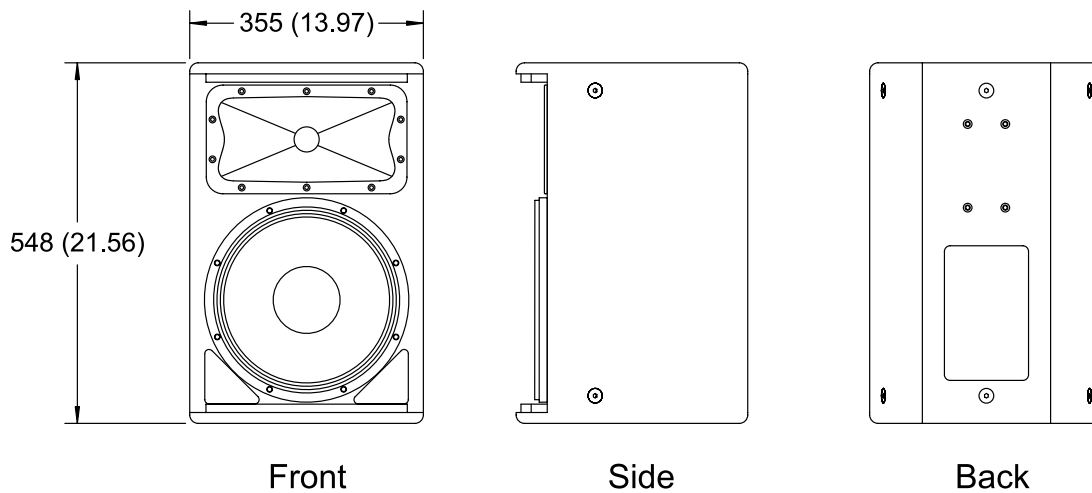

Horizontal 1/3 Octave Polars

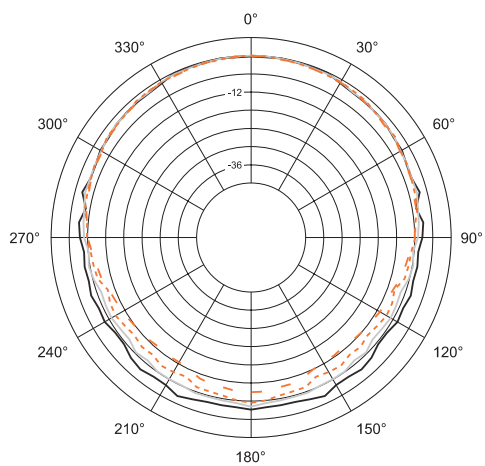

- 200Hz
- 250Hz
- - - 315Hz
- - - 400Hz

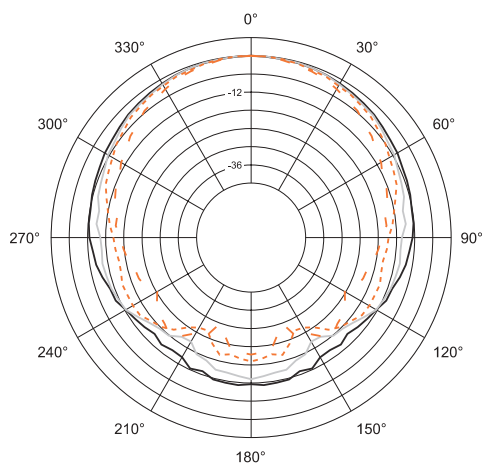

- 500Hz
- 630Hz
- - - 800Hz
- - - 1kHz

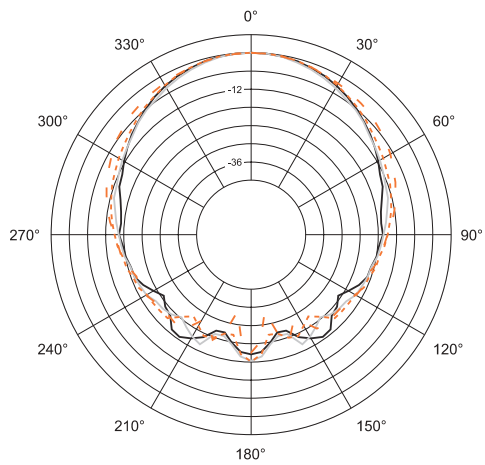

- 1.25kHz
- 1.6kHz
- - - 2kHz
- - - 2.5kHz

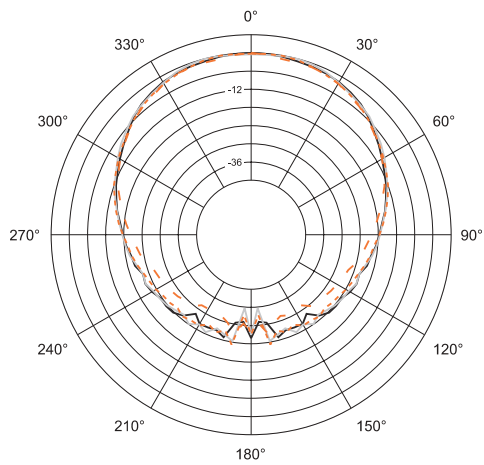

- 3.15kHz
- 4kHz
- - - 5kHz
- - - 6.3kHz

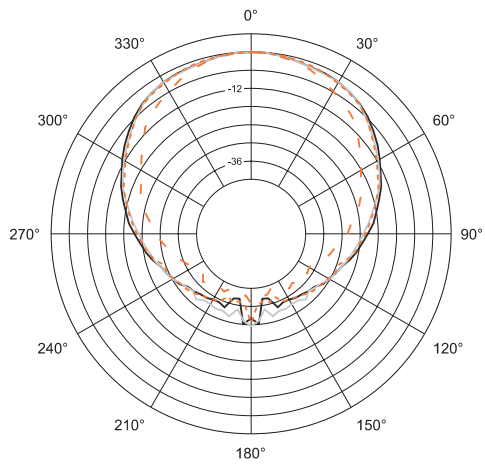

- 8kHz
- 10kHz
- - - 12.5kHz
- - - 16kHz

▶ AC2212/95 Compact 2-Way Loudspeaker with 1 x 12" LF

Vertical 1/3 Octave Polars

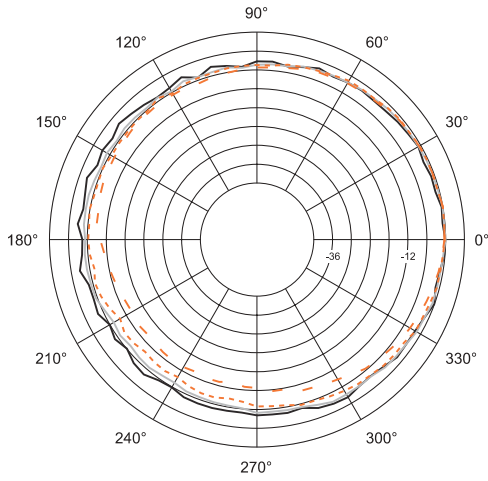

- 200Hz
- 250Hz
- - - 315Hz
- - - 400Hz

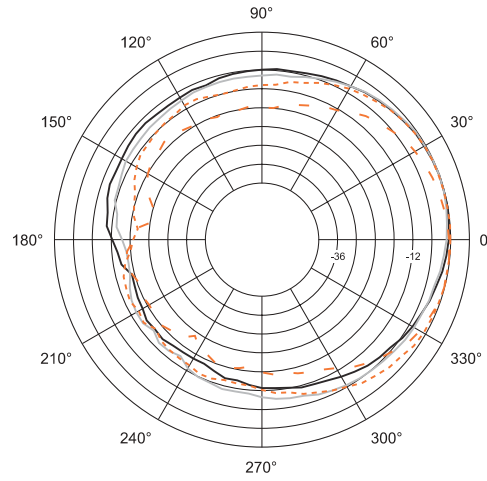

- 500Hz
- 630Hz
- - - 800Hz
- - - 1kHz

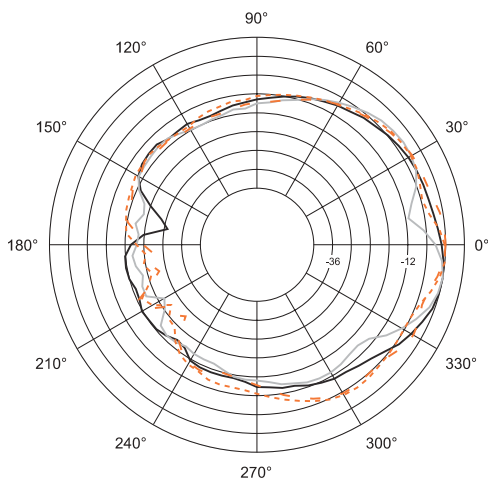

- 1.25kHz
- 1.6kHz
- - - 2kHz
- - - 2.5kHz

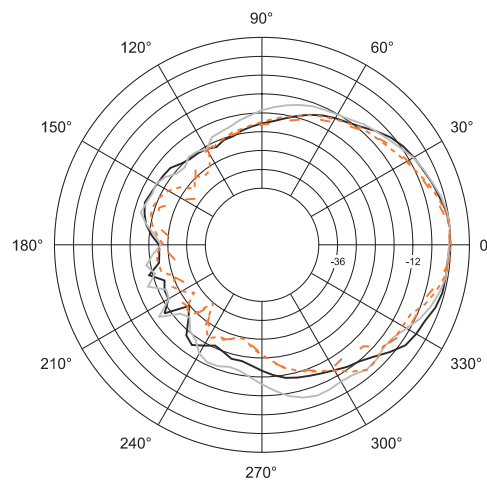

- 3.15kHz
- 4kHz
- - - 5kHz
- - - 6.3kHz

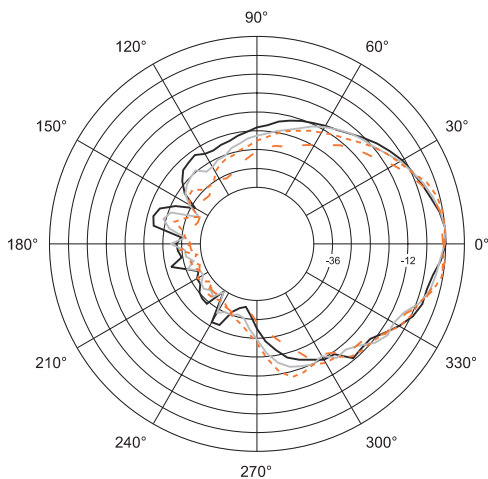

- 8kHz
- 10kHz
- - - 12.5kHz
- - - 16kHz



JBL Professional
 8500 Balboa Boulevard, P.O. Box 2200
 Northridge, California 91329 U.S.A.

■ A Harman International Company
 © Copyright 2002 JBL Professional

SS AC2212/95
 CRP 10M
 7/02