

# ANY SPOT<sup>®</sup> TRAVELER<sup>™</sup>

## AS-TV8 USER'S GUIDE



Wireless Portable Sound System



Compact, Lightweight  
Clear sound quality  
High output power



**GALAXY AUDIO**

MAKERS OF THE ORIGINAL HOT SPOT PERSONAL MONITOR

# Contents

Operating Manual for AS-TV8 Series.....	1
Front Panel Configuration of AS-TV8 Series.....	2
Rear Panel Configuration of AS-TV8 Series .....	3
Description of Functions of AS-TV8 Series.....	6
Caution Before Using the System.....	9
Installation and Operation of Portable Sound System.....	9
Wireless Mic/Receiver Audio Link.....	9
Anti Shock CD/CMP Player.....	10
Tone Controls.....	10
In/Out Jacks.....	11
Speaker Out.....	11
Digital Echo System.....	11
Audio Link Transmitter.....	11
Description of Functions for Handheld Microphone Front.....	13
Description of Functions for Handheld Microphone Back.....	14
Operation of Handheld Microphone.....	15
Description of Functions for Body Pack Transmitter.....	18
Operation of Body Pack Transmitter.....	19
Maintenance.....	21
Specifications.....	22-26
Key Specs/Overall System.....	23
Digital Echo Module.....	23
Audio Link Transmitter Module.....	24
Receiver Module.....	24
Handheld Microphone.....	25
Bodypack Transmitter.....	26

# Operating Manual for AS-TV8 Series

\*\*Please visit [www.galaxyaudio.com](http://www.galaxyaudio.com) for the latest updates\*\*

## Introduction

Galaxy Audio introduces the Any Spot Traveler (AS-TV8); a new AC/battery operated portable PA system. This compact system features an 8" woofer, 1" horn, 50-watt amplifier, and can be configured in a variety of ways to meet your specific needs. Features of the standard Traveler include: 2 Inputs (XLR/1/4" combo with its own volume control and a dual RCA), 2 Band EQ, and a Master Volume. Audio Outputs include a dual RCA Line Out and a 1/4" Speaker Output to power an additional speaker. The Universal Power Supply/Battery Charger allows the Traveler to be used anywhere in the world. The Traveler will operate for an unlimited time on AC power and for about 6 hours on just battery power. A full recharge of the batteries takes about 4 hours. The Traveler may be operated while recharging the batteries without affecting the charge time. If a power failure occurs when operating on AC, the Traveler will seamlessly switch over to battery power. The Traveler has a unique "plug in" modular design, which allows optional Function Modules to be easily added or removed. Optional Modules include Wireless Mic Receivers (with Handheld, Headset, & Lapel options), a CD/MP3 player, and the choice of an Echo/Delay unit or an Audio Link Module, which wirelessly transmits the entire audio mix from one Traveler to any number of satellite Travelers. Since all the Modules are internally wired, no external patching is necessary. The durable ABS enclosure features a convenient carry handle and a provision for standard pole mounting. The Traveler is designed for people who need a portable, lightweight, "all in one" PA system that allows for a quick and uncomplicated setup.



# Front Panel Configuration of AS-TV8 Series

## AS-TV8 Series

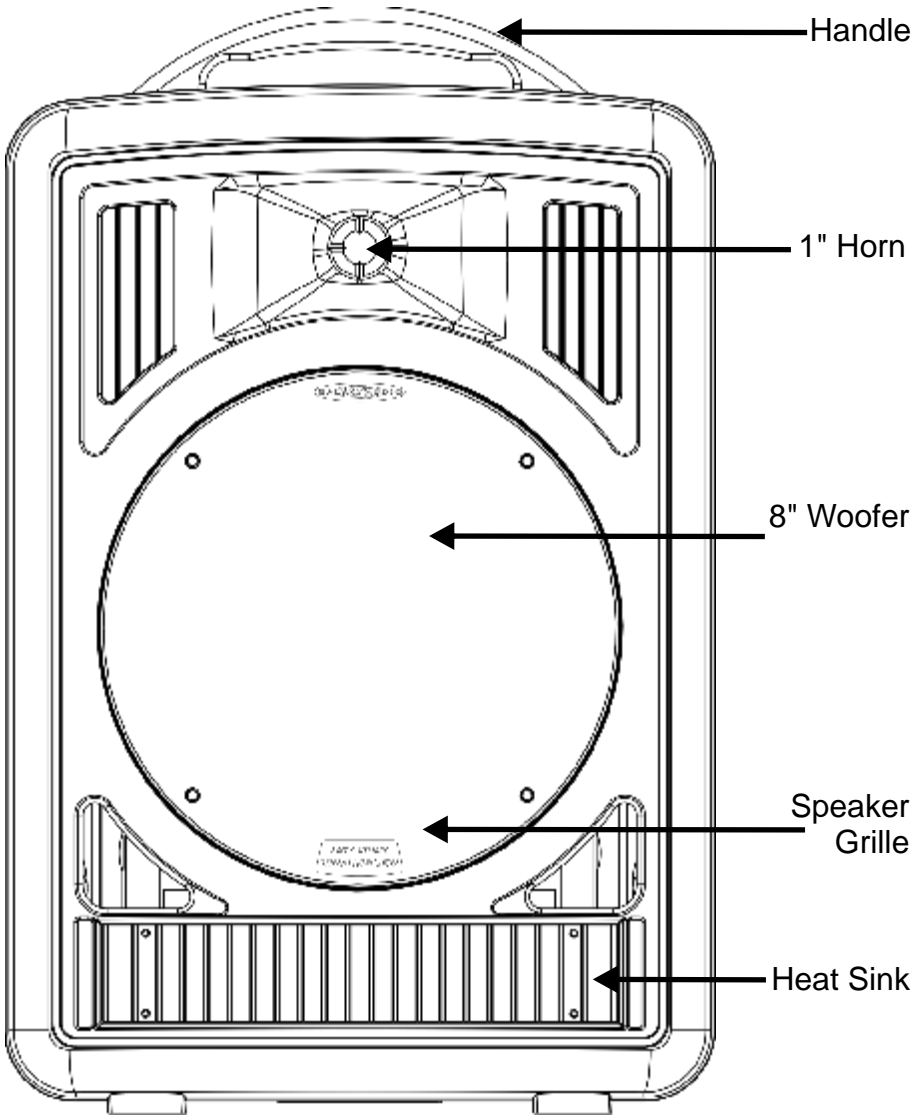

# Rear Panel Configuration of AS-TV8C2 Series

## AS-TV8C2

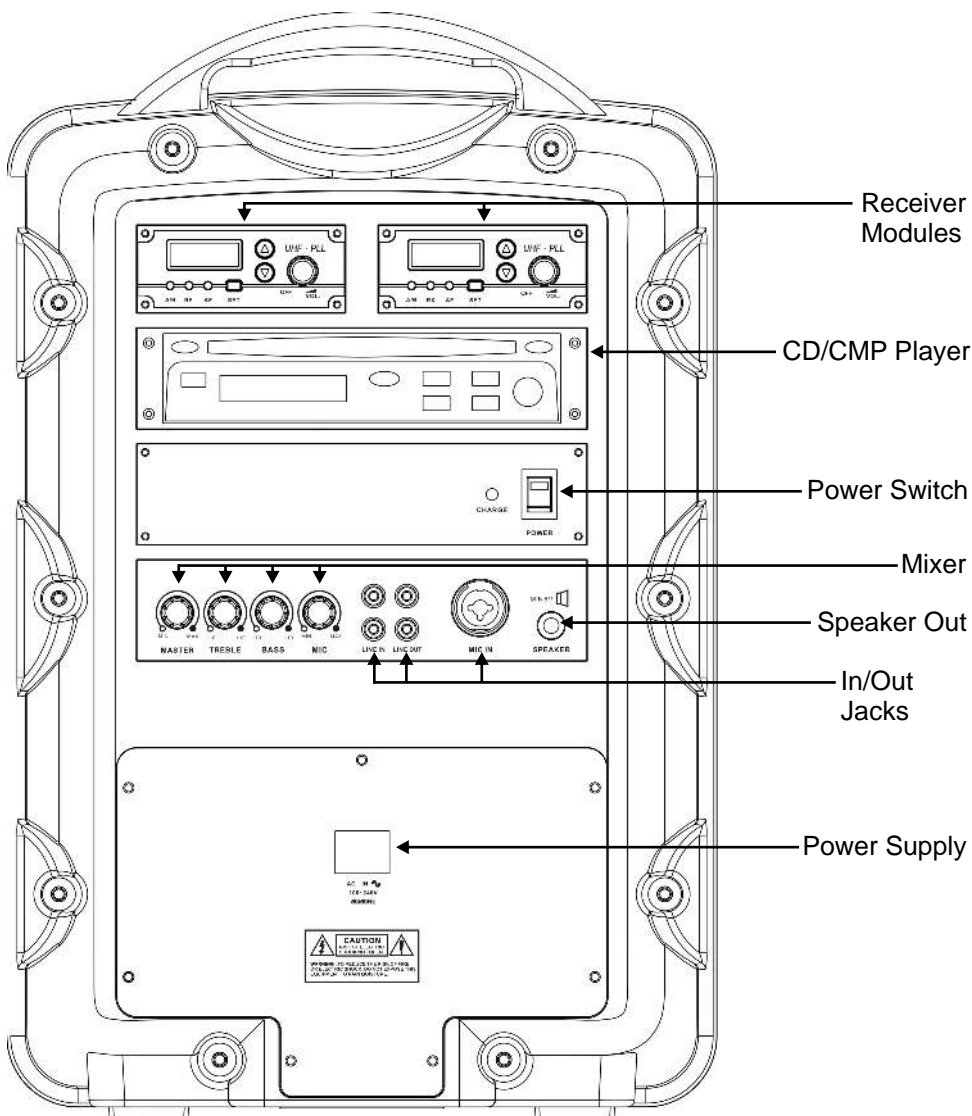

# Rear Panel Configuration of AS-TV8CE2 Series

## AS-TV8CE2

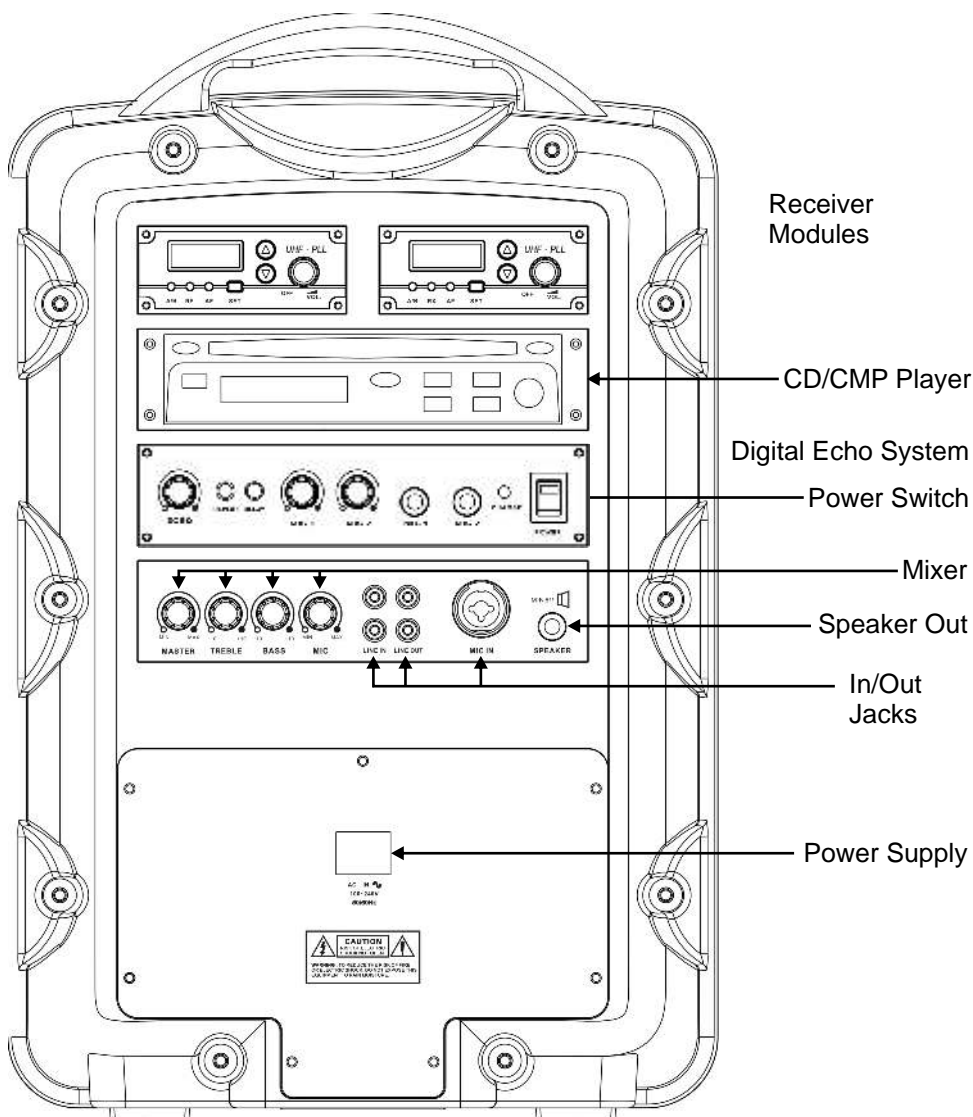

# Rear Panel Configuration of AS-TV8CT2 Series

## AS-TV8CT2

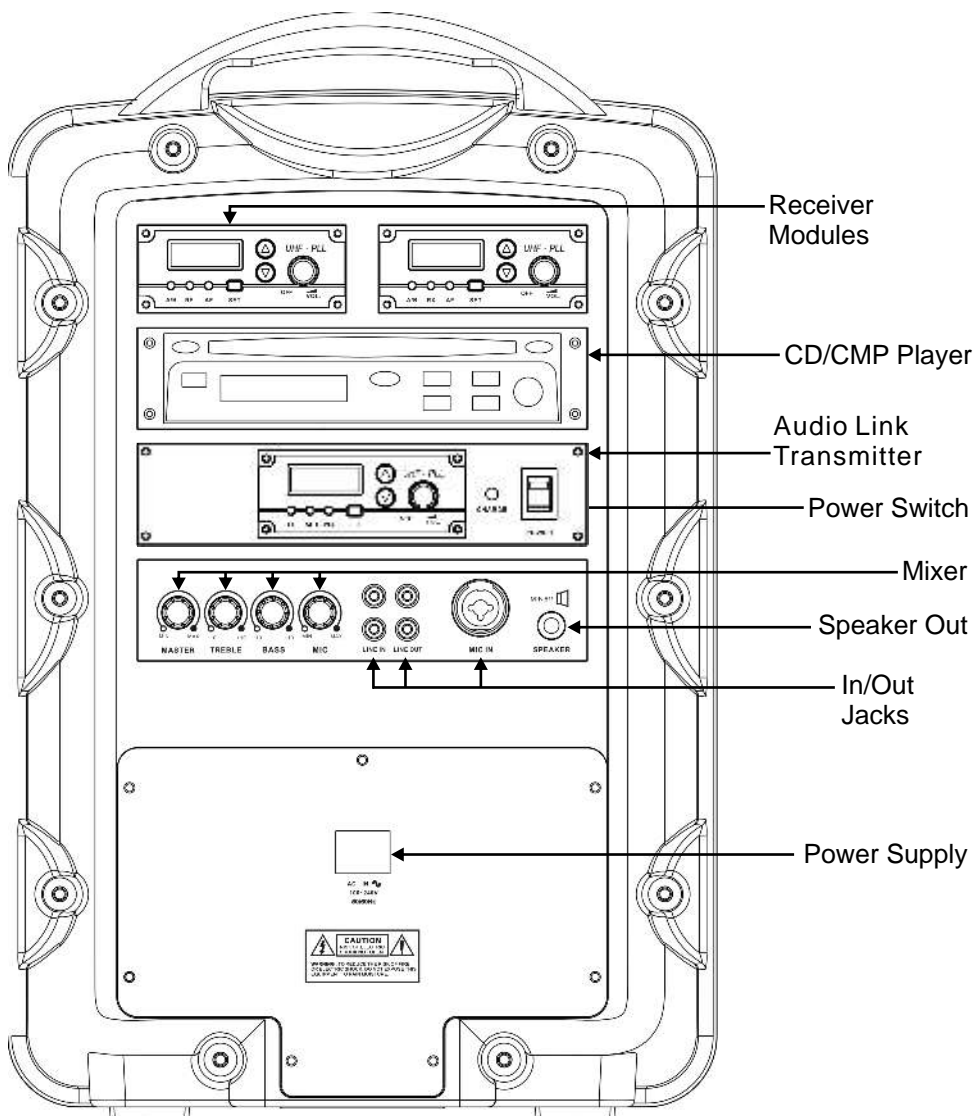

# Description of Functions for AS-TV8 Series

## A. Wireless Microphone/Audio Link Receiver

1. LCD display
2. A/B diversity indicator
3. RF indicator
4. AF level indicator
5. Channel Set
6. Channel selector
7. Power switch & mic. volume

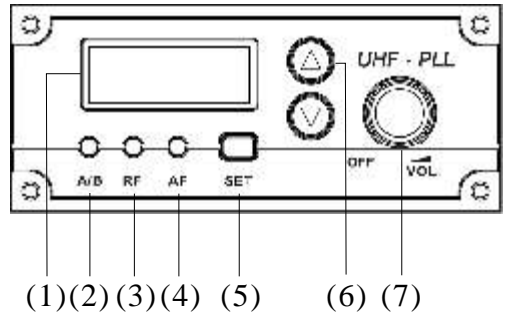

## B. Anti-Shock CD/CMP Player

1. Program Playlist
2. Power switch
3. LCD display
4. Shuffle/Repeat
5. Stop/Eject
6. Search and play the previous track
7. Search and play the next track
8. Play/Pause
9. CD volume
10. CD slot
11. CMP (Compressed Media Player) Folder

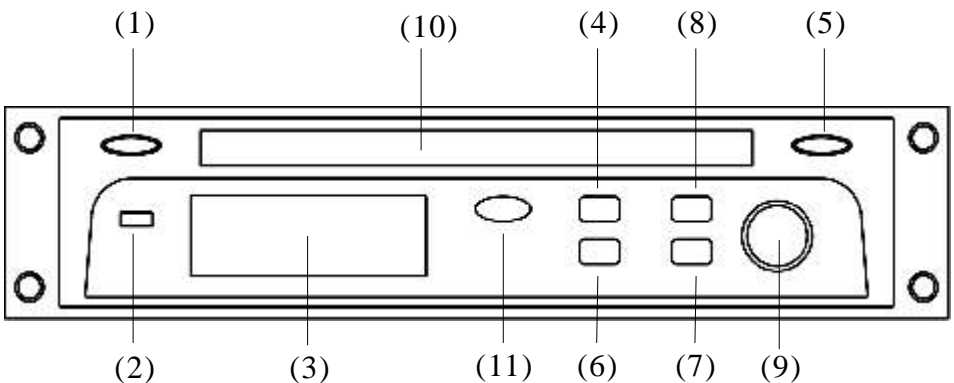

### C. Power Switch

1. Power LED
2. Charging indicator
3. Power On/Off switch

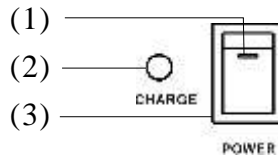

### D. Mixer

1. Master volume control
2. Treble control
3. Bass control
4. Mic volume control  
(For wired Mic connected to Mic in jack)

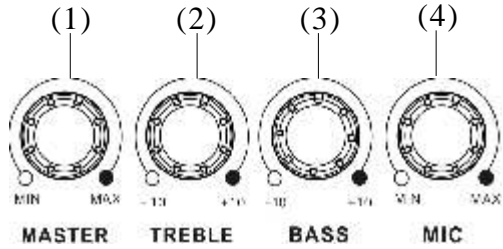

### E. In/Out Jacks

1. Line in RCA jacks
2. Line out RCA jacks
3. Mic in XLR/1/4" jack

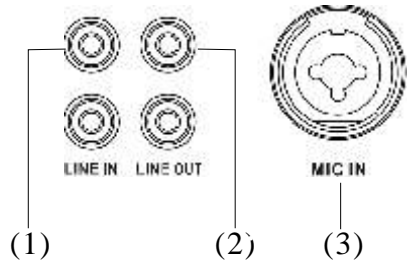

### F. Speaker Out

1. Speaker level output jack.  
Minimum 8 ohm external speaker

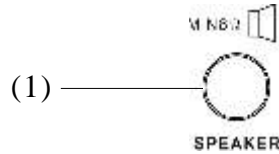

### G. Power Supply

1. AC Power Cable connector
2. Batteries (behind cover)
3. Battery cover

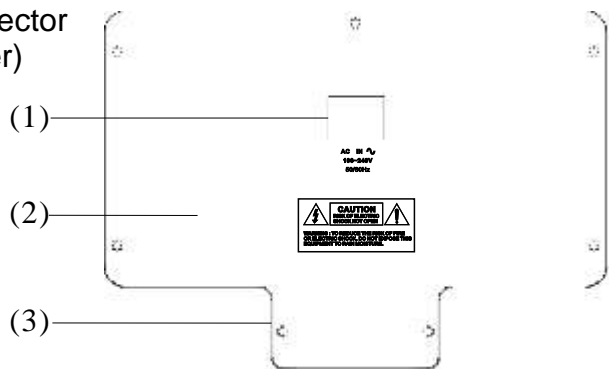

## H1. Digital Echo System (for AS-TV8CE2 )

1. Power switch and master echo volume control
2. Delay repeat control
3. Delay time control
4. Wired mic 1 volume control
5. Wired mic 2 volume control
6. Wired mic 1 1/4" input jack
7. Wired mic 2 1/4" input jack

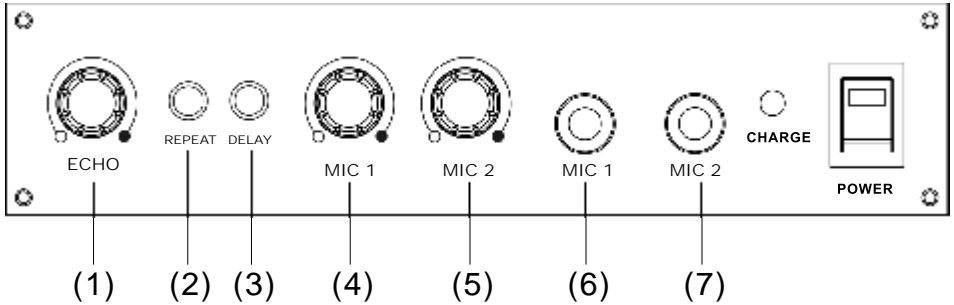

## H2. Audio Link Transmitter (AS-TV8CT2)

1. LCD display
2. TX indicator
3. Low audio level indicator
4. High audio level indicator
5. Enter Setting
6. Channel selector
7. Power switch and volume control

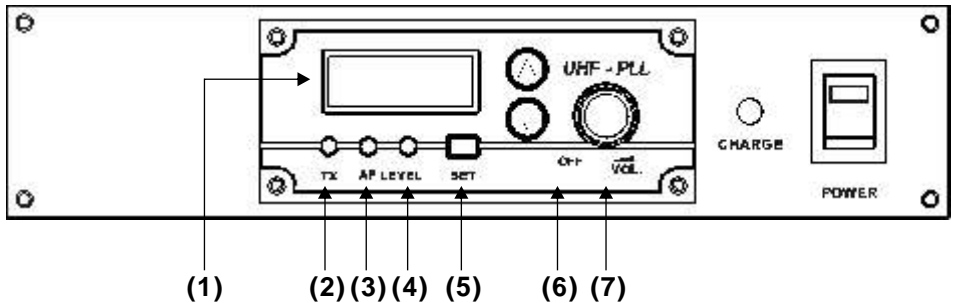

## Cautions Before Using the System

1. There is a universal AC switching power supply/charger built into the system that will operate on voltages of 100~240V,50/60Hz. Verify that the voltage to which you are connecting is in that range and then connect the AC power cord from the AC IN (**G1**) Pg. 7 to the wall outlet.
2. Charge the battery for at least 8 hours with the Power Switch OFF prior to first time use to maintain the quality of the battery and provide maximum operation time. When charging, the charging indicator (**C2**) Pg. 7 lights RED. When charging is almost complete, the indicator will flash RED and GREEN. After the battery is fully charged, the indicator lights GREEN. After the initial charge the Traveler may be operated on either AC or Battery power. When operating on AC power the Traveler will simultaneously recharge its internal batteries.
3. This system has auto protection circuitry for the battery that will protect the battery from being overcharged or overused. When running on battery power and the power switch LED (**C1**) Pg. 7 lights RED, the battery power is down to 30%. When the power switch flashes repeatedly, the battery is nearly exhausted and the system will turn off automatically to protect the battery.

## Installation and Operation of Portable Sound System

### A. Wireless Mic/Audio link Receiver (see page 6)

This system includes one or two receivers with selectable PLL 96 channel operation. These modules receive signals from wireless Mics or from another Traveler equipped with an Audio Link Transmitter.

1. Turn the power switch (**A7**) pg. 6 clockwise to turn on the receiver.
2. The LCD display (A1) will show "On" and the channel that was last in use when the unit was turned off.
3. To select a different channel, press the set button (A5). The channel number will flash in the in LCD display. Press the up or down button (A6) to select a channel to use, and then press the set button. After a channel has been set, press either the up or down button to display the frequency of the selected channel.
4. Adjust the volume control to a usable level.
5. When receiving signal, the A/B diversity indicator (A2) will light RED or Green to show the normal condition. The RF indicator (A3) will light to show RF received and the AF indicator (A4) will show audio received.

## B. Anti-Shock CD/CMP Player (see page 6)

1. Push the powerswitch **(B2)** Pg. 6 to turn on the player. Put a CD in the CD slot **(B10)** or push the Stop/Eject button **(B5)** to take a CD out of the slot.
2. Press the Play/Pause button **(B8)** to start or pause CD/MP3 play .Turn the volume control **(B9)** to adjust to the proper volume. Push the Stop/Eject button to stop or change the CD or CMP (Compressed Media Player) disc.
3. Press the Forward **(B7)** or Reverse **(B6)** button to skip forward to the next track or reverse to the previous track. Holding down the Forward or Reverse button will continuously forward or reverse the tracks.
4. Repeat/Shuffle **(B4)** has three modes:
  1. Repeat one song
  2. Repeat all songs
  3. Shuffle for random play.
5. Create Program Playlist:
  - Step 1: Press Prog button **(B1)** to begin setting up the program playlist
  - Step 2: Select a song (see step 3 and 6)
  - Step 3: Press Repeat **(B4)** to enter the song. Repeat steps 2 and 3 to enter additional songs.
  - Step 4: Press Play **(B4)** to play the programmed songs in memory

\*Please note that the program will reset once the Program button is pressed again.
6. To select a folder from an CMP, press Folder button **(B11)**. Use Forward or Reverse buttons to select a song.

## C. Tone Controls (Mixer) (see the page 7)

1. Turn the Treble control **(D2)** Pg. 7 counterclockwise to decrease the treble, and turn clockwise to increase the treble. The center position (straight up) produces a flat response.
2. Turn the Bass control **(D3)** counterclockwise to decrease the bass, and turn clockwise to increase the bass. The center position (straight up) produces a flat response.

## **D. In/Out Jacks** (see page 7)

1. The system contains Line In, Line Out, and Mic in jacks for connecting external audio devices.
2. Line In (**E1**): Pg.7 RCA jacks to connect external audio sources, such as CD/MP3 players or iPods. The volume of the Line In is controlled solely by the Master (**D1**).
3. Line Out (**E2**): RCA jacks to send the signal to other audio devices, such as recorders, mixers, or power amps.
4. Mic In (**E3**): XLR or 1/4" (6.3mm) phone jack for wired microphones. Volume of this input is controlled by Mic In (**D4**) and the Master (**D1**).

## **E. Speaker Out:** (see page 7)

1. Used to connect to an external unpowered speaker (8 Min.)

## **F. Digital Echo System** (see page 8)

1. Turn the power switch (**H1-1**) Pg.8 clockwise to turn on the echo system. Then use this control to adjust the level of echo in the mix .
2. Adjust the repeat button (**H1-2**) to select the number of repeats desired. Adjust the delay button to select the delay time.
3. Mic input jacks (**H1-6** and **H1-7**) are provided for connecting wired Mics. Mic volume is controlled by **H1-4** and **H1-5** plus the Master (**D-1**).

## **G. Audio Link Transmitter** (see page 8)

This module transmits the entire audio mix from one Traveler to another Traveler equipped with a wireless Mic/Audio Link Receiver.

1. Turn the power switch (**H2-7**) clockwise to turn on the transmitter.
2. The LCD display (**H2-1**) will show "On" and the channel in use when the unit was last turned off.
3. To select a different channel, press the set button (**H2-5**) and the channel will flash in the LCD display. Press the up or down button (**H2-6**) to select the transmit channel, and then press the set button again to enter the setting. The LCD will then automatically display the selected channel. To display the frequency of the selected channel press and hold either the up or down button.
4. Turn the volume control (**H2-7**) to adjust the audio transmit level. Use this control in conjunction with the volume controls on the receiving Traveler.

5. When transmitting signal, the TX indicator **(H2-2)** pg. 8 will light Green to show the transmitting condition. The AF Level indicator lights Yellow (H2-3) to show a low audio level and lights Red **(H2-4)** to show high audio level.
6. Set up the receiving Traveler according to the procedure outlined in: A. Wireless Mic/Audio Link Receiver on page 9. Select the channel chosen on the transmitting Traveler.

**Notice:** Changes or modifications not expressly approved by the party responsible for compliance could void the user's authority to operate the equipment.

**IMPORTANT NOTE:** To comply with the FCC RF exposure compliance requirements, no change to the antenna or the device is permitted. Any change to the antenna or the device could result in the device exceeding the RF exposure requirements and void the user's authority to operate the device.

This device complies with Part 15 of the FCC Rules. Operation is subject to the following two conditions: (1) this device may not cause harmful interference, and (2) this device must accept any interference received, including interference that may cause undesired operation.

# Description of Functions for Handheld Microphone

## Front Panel

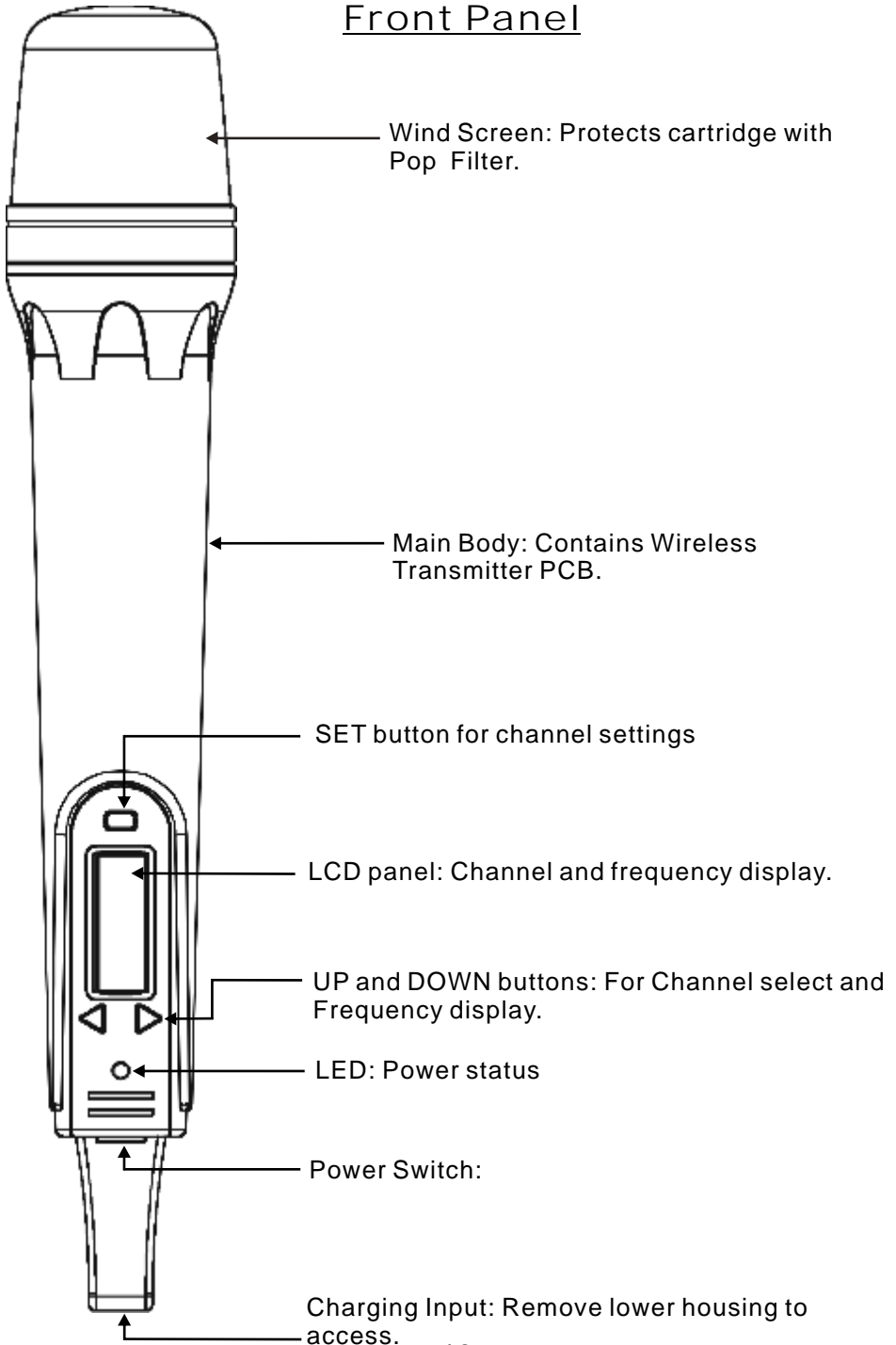

# Description of Functions for Handheld Microphone

## Rear Panel

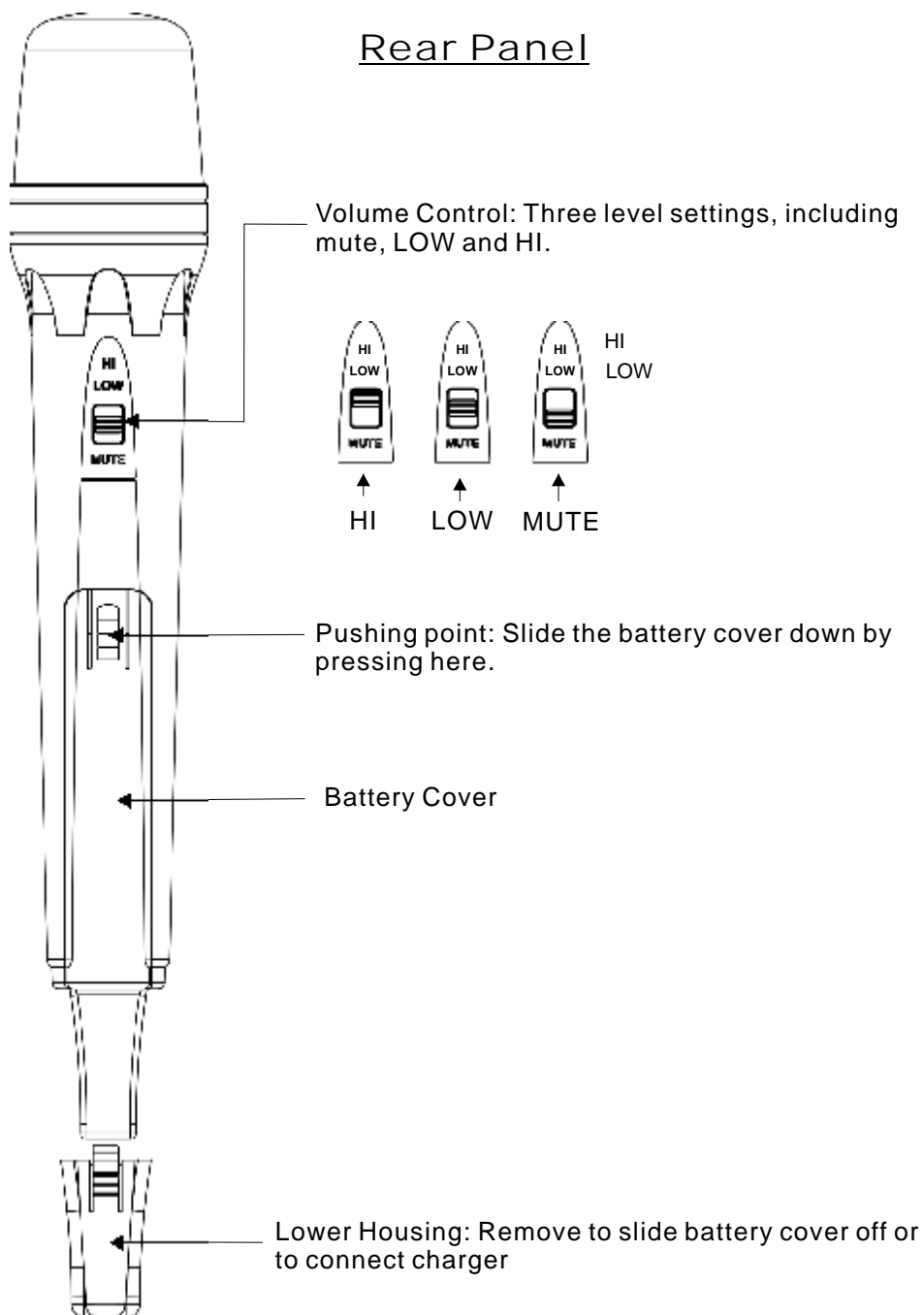

# Operation of Handheld Microphone

## A. Battery Installation Steps:

1. Turn off the microphone before inserting batteries.
2. Press in the latch to release the lower housing and slide it off.
3. Press in the latch to release the battery cover and slide it down.
4. Insert 2 disposable batteries of 1.5V type or 2 rechargeable batteries of 1.2V type.
5. Observe proper polarity while inserting batteries.
6. Slide the battery cover back to its original position.
7. Install the lower housing back to the lower part of the microphone.

## B. Switch-On Steps:

1. Press the power switch and hold for about two seconds until the LED turns to RED and "on" is displayed in the LCD. 
2. The LCD will then automatically display the selected channel.

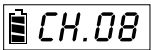
 :Channel indicator.

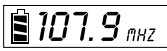
 :Press and hold the Up or Down button to display the corresponding frequency

## C. Switch Off steps:

1. Press and hold power switch for about two seconds until the LCD displays OFF. 

## D. Channel/Frequency Settings (with power on):

1. Press the SET button and hold for about 2 seconds.
2. The Channel number display will start flashing.
3. Press the Up button to display a higher numbered channel.

4. Press the Down button to display a lower numbered channel.

5. Press the SET button to activate the selected channel.

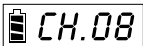
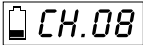
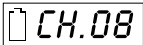

## E. LCD Indications:

1.  :Three bars means batteries are fully charged.
2.  :One bar indicates low batteries. Replace or recharge the batteries.
3.  :No bars showing indicates batteries are exhausted and after flashing three times the power will automatically shut off.

## F. Battery Charging Steps:

1. Rechargeable batteries need to be NiMH AA 1.2V with an amperage of 2100mAH or less as the charging function is limited to batteries of that rating.
2. Recharging is best accomplished by using the AS-TV8DCC charger

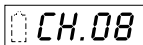
### 3. Charging status:

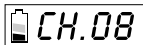
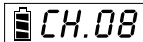
- a.  Battery indicator flashing: Non-Rechargeable batteries installed or no batteries installed. Check the batteries.
- b.  Battery indicator is flashing and LCD backlight is on: Failing, corroded, or over-temperature batteries.
- c.  One or two bars showing: Batteries are charging successfully.
- d.  Three bars showing: Batteries have been fully charged.

\* Please note the microphone will be turned off automatically while it is being charged.

## G. Trouble Shooting:

1. LED doesn't light when power switch is pressed to turn on mic.
  - a. Make sure that the batteries are not discharged.
  - b. Make sure that the batteries are installed correctly.
2. LCD shows Err when power switch is pressed to turn mic off.
  - a. Press the SET, UP and DOWN buttons at the same time in order to turn the microphone off automatically. The LCD display will flash about ten times and then the microphone will turn off automatically. The microphone should now turn on and off normally.
  - b. If the problem persists, call for service.
3. LCD panel shows unusual indications.
  - a. Remove the batteries from the microphone and re-install them.
4. No audio from microphone.
  - a. Check that the frequency of the transmitter is the same as that of the receiver.
  - b. Make sure that the Mic switch is not set to Mute.
  - c. Check if the distance between the transmitter and the receiver is too great.
  - d. Check if the transmitter or the receiver is too close to any large metal objects.
5. Interference and signal Disturbance.
  - a. Make sure there are no other wireless systems operating on the same frequency in the same area. This includes Microphones, televisions, radio stations, etc. Try setting the transmitter and receiver to a new channel.

## H. Q&A

1. Q: How long can the microphone be operated with fully charged batteries?  
A: Re-chargeable batteries will last approximately 8 to 10 hours. Disposable batteries will last approximately 13 hours.  
Q: How much time is required to recharge batteries from a fully exhausted state?  
A: Approximately 4 to 5 hours.

# Description of Functions for Body Pack Transmitter

1. Mini XLR Mic input jack (TA3M)
2. Power switch
3. Mute button
4. Antenna
5. Power light
6. Charging Jack
7. LCD light
8. Set button
9. Channel select button
10. Sensitivity control
11. 3.5mm aux input jack
12. Belt clip
13. Battery compartment
14. Battery cover

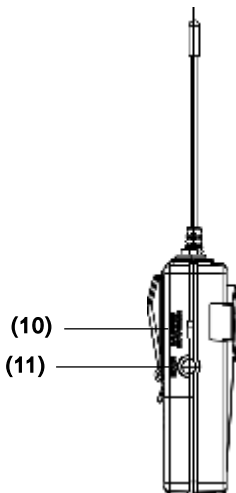
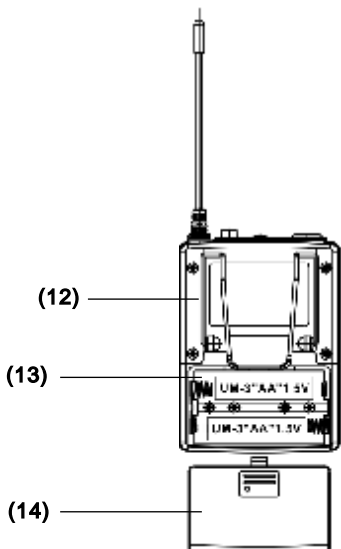
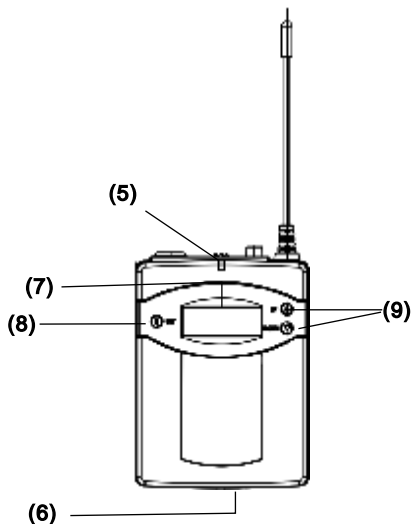
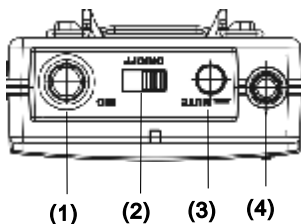

# Operation of Bodypack Transmitter

## A. Battery Installation:

1. Switch the transmitter off before inserting batteries.
2. Slide the battery cover off.
3. Insert 2 disposable batteries (1.5V AA) or 2 rechargeable batteries (1.2V AA).
4. Observe correct polarity when inserting batteries.
5. Slide the battery cover back to its original position.

## B. Turning unit on:

1. Switch the power to ON position

2. The RED LED will light and the LCD will display "On".

The image shows a rectangular LCD display with the word "On" in a bold, black, sans-serif font.

Battery status and channel will then appear.





If no other operation is performed, LCD light will go off automatically in 5 seconds.

## C. Channel/Frequency Settings:

1. Press and hold the SET button for approximately 2 seconds until the channel number flashes.
2. Release the SET button and the current channel will keep flashing
3. Press the UP or DOWN buttons to select a different channel.
4. When the desired channel is displayed press the SET button again. The display will stop flashing and stay on the channel selected.
5. Press and hold the UP or DOWN buttons to display the frequency associated with the channel number selected.

## D. Meanings of LCD appearance:

1.  Batteries fully charged and channel 08 selected.
2.  One bar displayed indicates low-battery. The batteries need to be changed or rechargeable batteries need to be recharged.
3.  No bars displayed indicates the batteries are exhausted and after flashing three times, the power will automatically shut off.

## E. Battery Charging Steps:

1. Insure that the batteries are the rechargeable type.
2. Switch Power to OFF position.
3. Insert AS-TVMBP into its own intelligent charger stand (AS-TV8DCC).
4. Batteries will recharge automatically.
5. For more details of charger stand please refer to AS-TV8DCC user guide.

## F. Turning the unit OFF:

1. Slide the power switch to the OFF position.

2. LCD display will show "OFF"



If there is no further operation, the Power LED and LCD will switch off automatically.

## G. Troubleshooting

1. No LCD display when the unit is switched on.
  - a. Make sure the batteries are not discharged.
  - b. Make sure the batteries are installed correctly.
2. LCD shows Err when switched on.
  - a. Switch power OFF, repeat steps for turning unit on.
  - b. If the problem persists, call for service
3. No Audio from Transmitter.
  - a. Check that the Transmitter and Receiver are on the same channel.
  - b. Check if "MUTE" is activated.
  - c. Check if the volume control of the receiver is set to a proper position.
  - d. Check if the Transmitter and Receiver are within the operating distance range.
4. Interference and signal disturbances.
  - a. When two Transmitters are being used, select different frequencies. If voice disturbance still occurs try selecting another channel until interference is gone.
  - b. Make sure there are no other wireless systems operating on the same frequency in the area. This includes other wireless microphones, television or radio stations, etc. Try setting the Transmitter and Receiver to a new channel.

# Maintenance

## **Avoid Excessive Heat**

Don't leave transmitter or receiver in hot sun, on a radiator, or near other sources of high temperature.

## **Avoid Rough Handling**

The transmitter and receiver may be damaged if dropped.

## **Storage**

Before storage, fully charge the batteries in both transmitters and receivers. If possible, recharge once a month during storage and again before first use.

## **Storage (Long term)**

Remove the internal batteries when storing the units for a long period of time.

## **Replacing Batteries**

Observe the correct polarity when installing batteries. Replace batteries only with the same or equivalent type.

## **Battery Terminals**

Keep the contacts clean and inspect them often to insure they are not corroded. If they become corroded, polish them with a pencil eraser.

## CAUTION

Danger of explosion if the battery is incorrectly installed.  
Replace only with the same or the equivalent type.



### Specifications Portable Amplifier Speaker

◦ Sensitivity	92 dB, 1Watt @ 1 M
◦ Maximum SPL	112 dB
◦ Frequency response	70 Hz ~ 20 kHz (audio)
◦ Speakers	8" LF woofer, 1" HF horn
◦ Receiver module	AS-TVREC x 2 @ diversity
◦ Output power	50 W RMS, 80 W MAX.
◦ Signal to noise ratio	Up 70 dB
◦ CD/CMP player	AS-CD (optional)
◦ Audio link TX	AS-TVTX transmitter (optional)
◦ Audio input	XLR-Mic. In, RCA-Line in
◦ Audio output	RCA-Line out, SPK Out (unswitched)
◦ Controls	Mic., Line, Bass, Treble, Master
◦ Power requirement	100-240V AC 50/60Hz
◦ Battery	12V, 2.9Ah * 2 (Lead-Acid) rechargeable batteries
◦ Operating life	4 ~ 6 Hours
◦ Charging time	4 ~ 6 Hours
◦ Dimensions (D x W x H)	12" x 9" x 18.5" (300 x 230 x 470 mm)
◦ Weight	26.5lbs (12 kg)

## Key Specifications / Overall System

• Oscillation type	PLL synthesized control OSC
• Carrier frequency range	Group 2. 794 ~ 806 MHz (96 ch.)
• Adjustable frequency	Pre-programmed max. 96 switchable channels
• Switching bandwidth	Max. 12 MHz
• Ambient temperature	-10 °C ~ 50 °C
• Maximum deviation	50 kHz, with level limiting
• Dynamic range	110 dB
• T. H. D.	Less than 0.5%
• Pre/De- emphasis	50 $\mu$ s
• Squelch	Tone key and noise lock dual-squelch
• Frequency response	70 Hz ~ 16 kHz (wireless)
• Operating range	160 - 230 feet (50 ~ 70 M) (open field) with built-in antenna

## Digital Echo Module

• Input sensitivity	10 mV
• Delay time	110 ms ~ 340 ms
• Audio input	6.3 $\phi$ -Mic in * 2 TRS, Low 2
• Controls	Echo, Repeat, Delay, MIC1, MIC2

## Audio Link Transmitter Module

◦ RF output	10mW
◦ Spurious emission	Less than 250 nW
◦ Display status	LCD indicator displays channel or frequency
◦ Channel select	SET, UP, DOWN keys
◦ Antenna	Built-in or external
◦ Dimensions ( L x W x H )	4.25" x 7.5" x 1.75" (108 x 190 x 44 mm)
◦ Weight	5.99 oz. (170 g)

## Wireless Mic/Audio link Receiver Module

◦ Antenna mode	Diversity
◦ Sensitivity	4 $\mu$ V @ 30 dB SINAD
◦ Double intermediate	110.6 Mhz / 10.7 MHz
◦ Display status	LCD indicator displays channel or frequency
◦ Channel select	SET, UP, DOWN keys
◦ RF spurious rejection	70 dB
◦ Adjacent channel performance	68 dB @ 250kHz
◦ IMD rejection	58 dB
◦ Antenna	Built-in or external
◦ Dimensions ( L x W x H )	5.25" x 3.46" x 1.45" (133 x 88 x 37 mm)
◦ Weight	3.88 oz. (110 g)

# Handheld Microphone

◦ Microphone type	Cardioid dynamic capsule
◦ RF output	10mW
◦ Spurious emission	Less than 250 nW
◦ Display status	LCD indicator displays channel or frequency, battery condition
◦ Channel select	SET, UP, DOWN keys
◦ AF controls	Hi/Low/Mute switch
◦ Battery	1.2 V (Ni-MH 1300 mAh) * 2 AA type rechargeable battery 1.5V * 2 AA Alkaline disposable
◦ Battery life Ni-MH rechargeable	11 hours typical
◦ Battery life Alkaline disposable	14 hours typical
◦ Antenna	Built-in
◦ Dimensions (Dia x L)	1.8" x 10.4" (46 x 264 mm)
◦ Weight with battery	9.87 oz. (280 g)

# Bodypack Transmitter

◦ Mike	Condenser mic.
◦ RF output	10mW
◦ Spurious emission	Less than 250 nW
◦ Display status	LCD indicator displays channel or frequency, battery life
◦ Channel select	SET, UP, DOWN keys
◦ AF controls	Mute switch, Hi/Mid/Low switch
◦ Audio input	Mic in, Aux in
◦ Battery	1.2 V (Ni-MH 1300 mAh) * 2 AA type rechargeable battery 1.5V * 2 AA Alkaline disposable
◦ Battery life Ni-MH rechargeable	11 hours typical
◦ Battery life Alkaline disposable	14 hours typical
◦ Housing	Aluminium
◦ Dimensions ( D x W x H )	1.04" x 2.52" x 3.48" (27 x 64 x 88 mm)
◦ Weight with battery	4.48 oz. (127 g)

# REGISTRATION CARD

Registration information is used ONLY by GALAXY AUDIO and will be kept strictly confidential.

## Registration

Name \_\_\_\_\_ Phone \_\_\_\_\_  
Address \_\_\_\_\_  
City, State, Zip \_\_\_\_\_  
email \_\_\_\_\_  
Dealer \_\_\_\_\_ Purchase Date \_\_\_\_\_

Serial number

Model

This Galaxy Audio product will be used for:

- Live Sound   
Church   
**Recording**  
Home/Project Studio   
Commercial Studio   
Post-Production/Mastering

## Broadcast

- On-Air   
Production

What magazines do you read? \_\_\_\_\_  
\_\_\_\_\_  
\_\_\_\_\_  
\_\_\_\_\_  
\_\_\_\_\_  
How can Galaxy Audio better serve you?  
\_\_\_\_\_  
\_\_\_\_\_  
\_\_\_\_\_  
\_\_\_\_\_

PLACE  
STAMP  
HERE

---

---

---

---

---

---

GALAXY AUDIO  
P.O. BOX 16285  
WICHITA, KS 67216-0285

# LIMITED WARRANTY

This warranty gives you specific legal rights, and you may also have other rights which may vary from state to state. This warranty is extended to the purchaser and to any purchaser from him for value.

GALAXY AUDIO warrants the materials and workmanship of its products from the date of the original purchase.

1. Hot Spot Series, Micro Spot Series, Audio Solutions (including Cricket, Jacks In the Box, & Check Mate) are products covered by 3 year warranty.
2. Any Spot Wireless, including Wireless Personal Monitor (WPM), Assistive Listening System, 500 Series Wireless Microphone, 700 Series Wireless Microphone, Lightweight Headset Microphones, Tour Guide/Translator System, Wireless Camera Kit are covered by a 1 year warranty.
3. The Traveler is supported with a 3 year warranty on speaker components and casing, and a 1 year warranty on wireless and CD/MP3 player components.
4. Any units containing a battery will have a 90 day warranty on the battery.

The following are not covered by the warranty:

1. Damage to or deterioration of the exterior cabinet which occurs after delivery.
2. Damage after initial delivery resulting from accident, misuse or neglect.
3. Damage resulting from failure to follow instructions contained in the owner's manual.
4. Damage resulting from the performance of repairs by someone other than GALAXY AUDIO or an authorized GALAXY AUDIO service center.
5. Damage occurring during the shipment or delivery of any GALAXY AUDIO product to GALAXY AUDIO or an authorized service center after initial delivery of the product to you.
6. Damage to any GALAXY AUDIO product which has been altered, or on which the serial number has been effaced or removed.

If your unit requires service, it must be returned, shipping charges prepaid to an authorized GALAXY AUDIO service center in the United States. (This warranty is not enforceable outside the U.S.) If you are not able to locate an authorized service center in your area, please call or write GALAXY AUDIO, 601 E.Pawnee, Wichita, Kansas 67211, (316) 263-2852. We will then refer you to an authorized service center to which the unit may be returned, or we may advise you to return your unit to the factory for service. Under no circumstances should you return your unit to the factory without written instruction to do so. If service is required, you must present the original or a copy of the bill of sale as a proof of date of purchase of your unit. Upon receipt of your unit for service, GALAXY AUDIO or the authorized service center will repair or replace your unit as soon as possible, but in no event later than 30 days after the receipt of the unit. We will return the unit to you, shipping charges prepaid, provided the necessary repairs are covered by this warranty. IMPLIED WARRANTIES OF MERCHANTABILITY AND FITNESS FOR PARTICULAR PURPOSE ARE LIMITED IN DURATION TO THE LENGTH OF THIS WARRANTY, UNLESS OTHERWISE PROVIDED FOR BY STATE LAW. GALAXY AUDIO'S LIABILITY IS LIMITED TO THE REPAIR OR REPLACEMENT, AT OUR OPTION, OF ANY DEFECTIVE PRODUCT, AND SHALL IN NO EVENT INCLUDE INCIDENTAL OR CONSEQUENTIAL DAMAGES OF ANY KIND. SOME STATES DO NOT ALLOW LIMITATIONS ON HOW LONG AN IMPLIED WARRANTY LASTS AND/OR DO NOT ALLOW THE EXCLUSION OR LIMITATION OF INCIDENTAL OR CONSEQUENTIAL DAMAGES, SO THE ABOVE LIMITATIONS AND EXCLUSIONS MAY NOT APPLY TO YOU.

GALAXY AUDIO does not authorize any third party, including any dealer or Authorized Service Center, to assume any liability on behalf of GALAXY AUDIO or to make any warranty for GALAXY AUDIO.

GALAXY AUDIO®

MAKERS OF THE ORIGINAL HOT SPOT PERSONAL MONITOR