

### Digital Matrix Processor



- 8-in/4-out digital matrix architecture in a stackable configuration
- Programmable front panel level controls with activity LEDs
- 6 filters, 6 feedback eliminators (ADFE), compressor and delay on each input
- 9 filters, delay and compressor/limiter on each output
- USB and RS-232 interfaces for setup and comprehensive remote control
- Balanced, floating differential inputs and outputs - no pin 1 problem
- Digital I/O ports for "daisy chaining" and to connect other LecNet 2 devices
- Proportional gain auto mixing algorithm with AutoSkew™ - US Patent 5,414,776
- 128 global macros, each with up to 64 commands, and 115 characters per command

The DM84 combines a stackable 8-in/4-out automatic matrix mixer with a powerful DSP signal processing package and extensive remote control capabilities for any sound system application with multiple microphones and loudspeakers. Multiple DM84 units can be stacked to expand the matrix with unlimited inputs and up to 12 outputs. The unit also supports the full LecNet2 digital matrix, so it can also be integrated with other DM Series processors in 24 output systems.

The primary applications are in sound reinforcement and recording in boardrooms, courtrooms, worship centers, distance learning systems, hotels and other applications that benefit from matrix signal routing, automatic mixing and remote control options. Once setup is completed with the supplied LecNet2 software, the unit runs as a stand-alone device. Front panel controls are provided to make minor adjustments to the input and output levels, expanding its usefulness into stand-alone applications. The adjustment range of each control is defined in the software setup to optimize it for various needs.

The DSP features include a full complement of filters, ADFE (automatic digital feedback eliminators), compressors, limiters and delay on every channel to optimize the signal processing needed for every application. This processing is available at the inputs to compensate for microphone placement and signal characteristics, or to adjust for differences in tonal quality or dynamics of various signal sources. Each output has individual filters and a proprietary, adaptive time constant compressor/limiter to feed recorders or power amplifiers.

Extensive control capability is built into the unit with an intuitive command structure to allow external control with USB or RS-232 connections. Touch panel control systems easily integrate into the command structure. Remote control, monitoring and setup can also be done via ethernet connections using a low cost interface provided by another manufacturer.

Up to 128 macros can be stored in internal memory. Each macro can contain up to 64 commands, with 115 characters in each command. Macros can be invoked with serial commands from touch panel control systems or contact switches connected to the logic I/O ports on the rear panel. The macros can be chained so that one macro can call another one, which may call yet another one. In addition, a built-in macro recorder greatly simplifies the creation and use of macros.

The audio inputs and outputs are balanced, differential circuits (no pin 1 problem) to eliminate noise from external RF and power sources, even with long cable runs.

The patented gain proportional automatic mixing algorithm\* is applied at the crosspoints in the matrix so each input can behave differently at each output. For example, input 4 can be a microphone that participates in the NOM attenuation applied by the auto mixing algorithm at some of the outputs, and operate as a direct signal for recording at other outputs.

# General Overview

The LecNet2 product group introduces a powerful series of audio components and unique solutions for the design and installation of sound systems with multiple microphones and loudspeakers. The DM84 is a very useful member of this family in that it can satisfy cost conscious applications in stand-alone operation, or function as a building block to configure larger systems. It addresses the full digital matrix of the DM Series so it can also be used with other models to add additional inputs and outputs. The range of the front panel level controls can be configured to suit specific preferences.

## Digital Matrix

The digital signal flow provides an expandable digital matrix with no crosspoint limitations. Automatic mixing takes place at the crosspoint in the matrix so that every input can participate in every output group at a different level and with a different auto mixing behavior to optimize the channel behavior for specific purposes.

In addition, a DANI (Digital Audio Network Interface) bus is provided so that the digital audio signals and data from the master and slave units are connected in stacked configurations in larger sound systems.

## Automixer Cell

The Automixer Cell is the core of the matrix. It is where level control for the automatic mixing algorithm, mixing mode and crosspoint gain is applied using data gathered from other channels and devices. In a stacked configuration, the cell receives data from the master unit above it and from the slave units below it. The final mix is generated in the master unit and the data is returned back to slave units to implement automatic mixing.

## Power of the Mix

The Power of the Mix is the reference used to determine the gain to be applied to each individual output channel. In a multi-unit stacked configuration, this data is sent to the slaves from the master unit.

## Crosspoint Gain

Crosspoint Gain is the gain selected with the control panel that determines the level at the output.

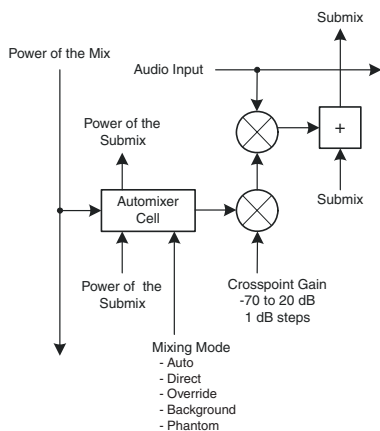

Digital Matrix Functional Block Diagram (single crosspoint shown)

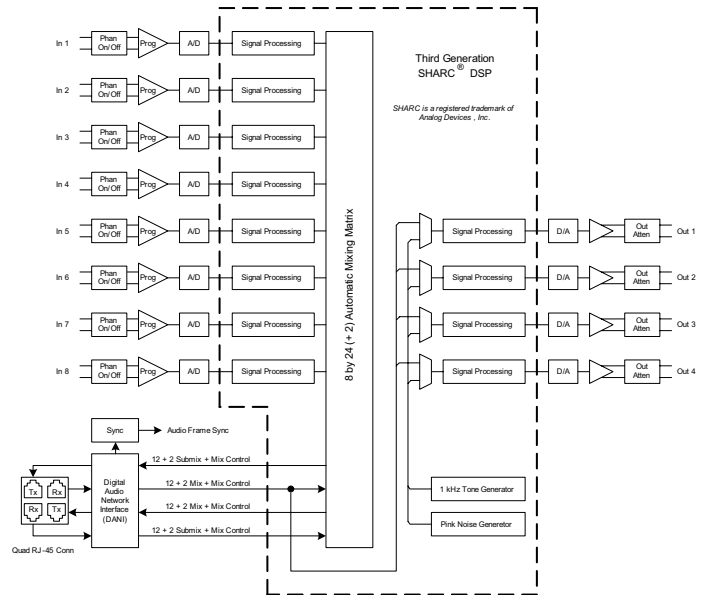
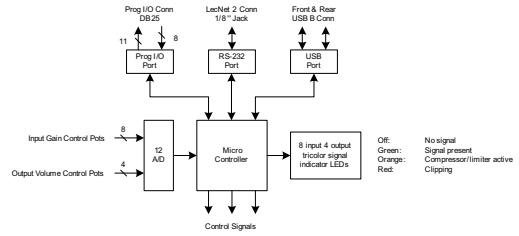

DM84 Functional Block Diagram

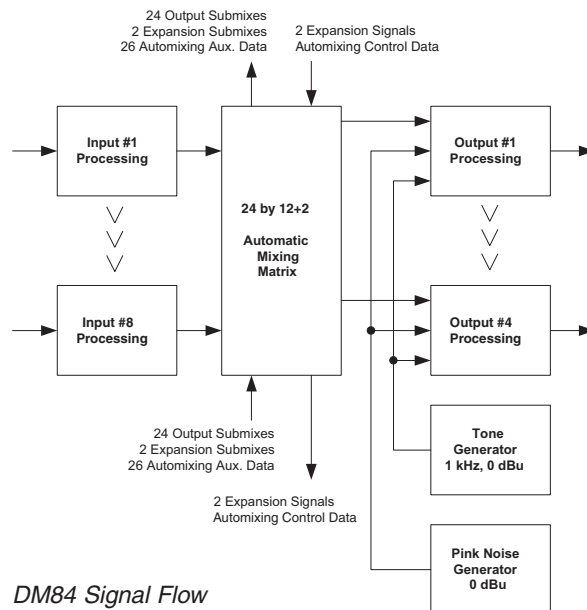

DM84 Signal Flow

# LecNet2 Software

Software is included with the DM84 and available for download from the website at: [www.lectrosonics.com](http://www.lectrosonics.com). The software is used primarily for setup, with the configuration saved on file and into the unit's memory for actual operation. Once configured, the DM84 runs without a host computer.

The software is user-friendly, with a variety of screens provided for each section of the signal flow and system design. The software runs under Windows® 2000 and XP operating systems using a familiar tabbed layout. A few sample screens are shown below.

## Mixing Mode

The automatic mixing algorithm applies a patented gain proportional algorithm (*US Patents #5,414,776 and #5,402,500*) allowing each input assigned to a particular output to behave differently relative to the other inputs assigned to the output.

Five different mixing modes are available:

**Auto** - In automatic mode the input applied to the crosspoint is mixed into the output channel using the Adaptive Proportional Gain automixing algorithm in the normal manner. This is the most common setting.

**Direct** - In Direct mode the automixing algorithm is bypassed.

**Override** - Override mode is selected when it is required that the input applied to the crosspoint **always** dominates the output channel when it becomes active.

**Background** - Background mode is selected when it is required that the input applied to the crosspoint dominates the output channel **only** when all other inputs are inactive.

**Phantom** - A special mode that allows an input to participate in the auto mixing activity at one or more crosspoints, but the audio signal is not delivered to the output. In essence, the NOM mixing activity is separated from the actual audio signal. This allows NOM attenuation to take place between zones in a mix-minus sound system design. It preserves the discrete signal routing implemented in a mix-minus sound reinforcement system that isolates microphones and loudspeakers.

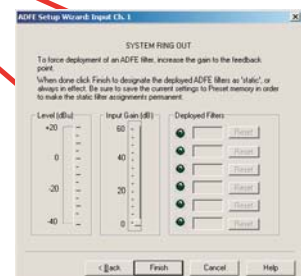
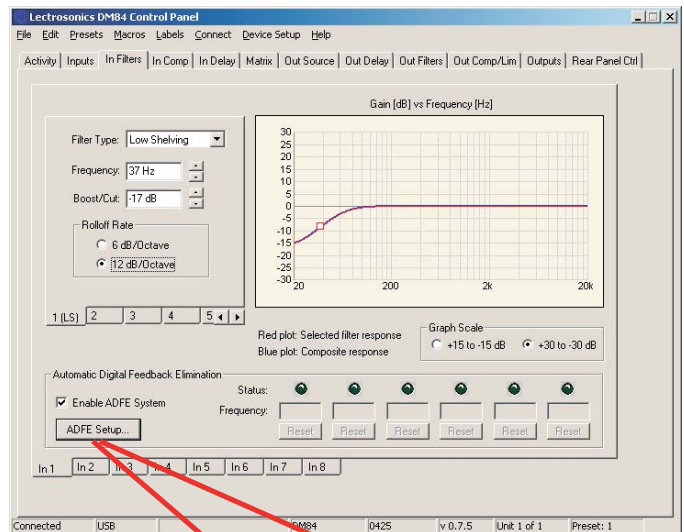
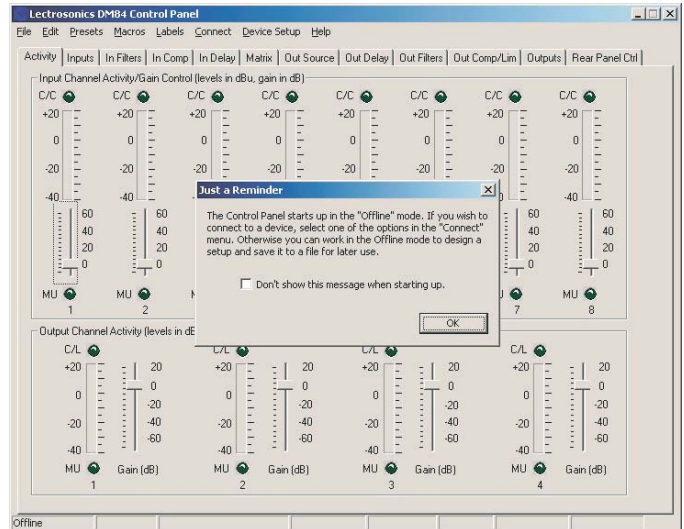

\*Windows is a registered trademark of Microsoft Corp.

# Input Processing

Each input channel provides individual stages for gain, filtering and compression and delay.

## Input Gain

The input applies software controllable gain with a level indicator and clipping indicator.

## Filters

Up to six filters can be implemented at each input to idealize the signal equalization.

The filter types include:

- Low pass
- High pass
- Band pass
- Parametric EQ
- Low shelving
- High shelving

Filter slopes can be selected with 6 or 12 dB per octave Butterworth or Bessel parameters. Multiple filters can be assigned to create steeper slopes in 6 dB steps.

## ADFE (automatic digital feedback eliminator)

Six narrowband notch filters are automatically placed on ringing and/or oscillating frequencies to cancel acoustic feedback. A pop-up screen provides a utility to manually increase the gain in small increments to “ring out” the sound system. As the ringing begins to occur the filters are automatically placed. The filters can then be stored as static filters in the presets.

## Input Compressor

The compressor implementation is a unique “soft knee” type based on an RMS level detector controlled by a single time constant parameter. This is a new design which responds to varying rates of change in the signal level by dynamically adjusting the attack and release times for best performance. Adjustment is simplified by entering a single value (half of the desired release time). The attack time is then applied by the DSP to vary with the signal.

The default value is 100 ms, which sets the release time at about 200 ms. The attack time is signal controlled and varies from about 2 ms to about 100 ms as is needed to handle the signal dynamics. See the reference manual for a closer look at this unique and very effective compressor.

Compressor adjustment parameters include:

- Threshold
- Time Constant
- Compression ratio
- Makeup gain

## Delay

The input delay can be set up to 100 ms in .50 ms increments. The delay can also be set according to distance in either feet or meters.

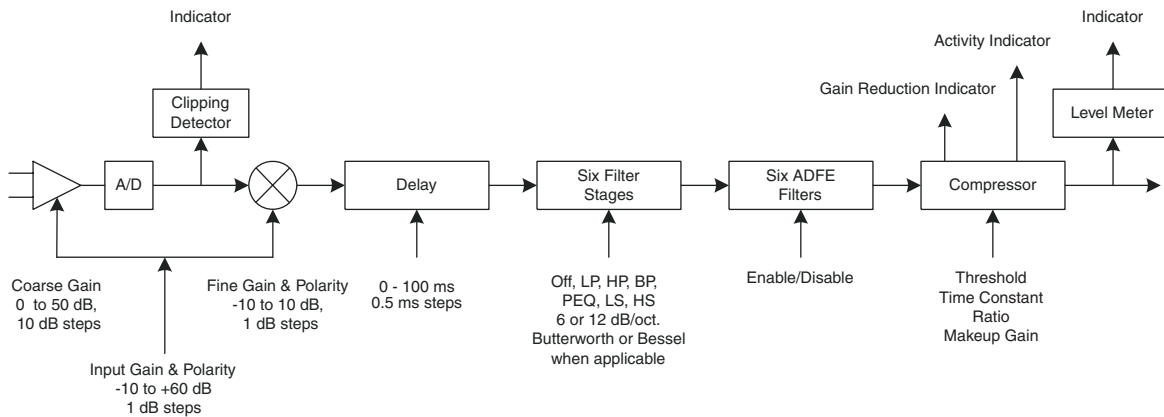

Typical Input Signal Processing Blocks

# Output Processing

## Output Source Select

In normal operation the digital matrix delivers the audio signals to the outputs, which consist of the final mixes backpropagated from the master unit in the system via the Digital Audio Network Interface (DANI), with 12 mixes from the main matrix and 2 mixes from the expansion matrix. Internal pink noise and 1 kHz tone generators are also available at each output for diagnostics, setup and sound masking purposes.

## Output Gain and Level Indicator

The output level can be adjusted from -70 dBu to +20 dBu in 1 dB steps to perfectly match the requirements of the device being fed by the channel. A bar graph is provided by the on screen GUI to accurately indicate the output level as it operates and is adjusted.

## Delay

A delay of up to 250 ms in .50 ms increments is provided at each output. The delay can also be set according to distance in either feet or meters.

## Filters

Up to nine filters can be implemented at each output to idealize the signal equalization:

- Low pass
- High pass
- Band pass
- Parametric EQ
- Low shelving
- High shelving

Filter slopes can be selected with 6 or 12 dB per octave Butterworth or Bessel parameters. Multiple filters can be assigned with the same values to create steeper slopes in 6 dB steps.

## Output Compressor and Limiter

A versatile compressor and limiter are provided at each output to control the average level and dynamics of the audio signal, and restrict the maximum output level to optimize the channel for its purpose. Compression is often needed when the channel is feeding a recorder, and limiting is often used to protect a loudspeaker system and reduce distortion and amplifier overload.

The compressor implementation is a unique “soft knee” type based on an RMS level detector controlled by a single time constant parameter. This is a new design which responds to varying rates of change in the signal level by dynamically adjusting the attack and release times for best performance. Adjustment is simplified by entering a single value (half of the desired release time). The attack time is then applied by the DSP to vary with the signal.

The default value is 100 ms, which sets the release time at about 200 ms. The attack time is signal controlled and varies from about 2 ms to about 100 ms as is needed to handle the signal dynamics. See the reference manual for a closer look at this unique and very effective compressor.

Compressor adjustment parameters include:

- Threshold
- Time Constant
- Compression ratio
- Makeup gain

Limiter adjustment parameters include:

- Threshold
- Time Constant

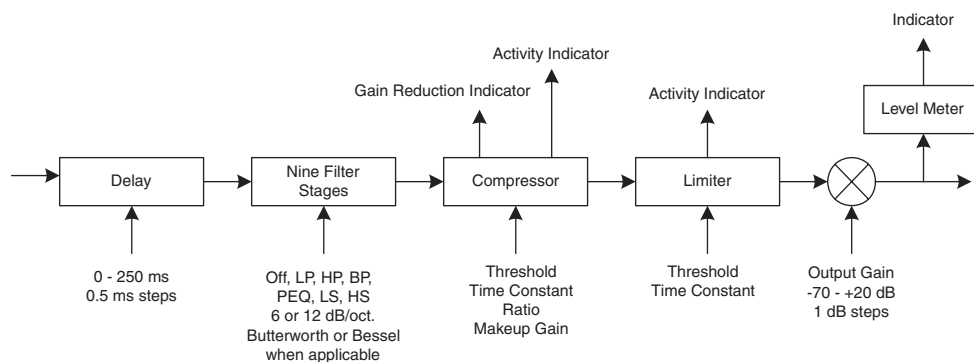

Typical Output Signal Processing Blocks

# The DANI Bus and Back Propagation

The core of the DM Series processors consists of a digital matrix and a digital bus called DANI (digital audio network interface). The digital matrix is common to all units in a system. The DANI bus interconnects the hardware to allow access to the matrix signal flow and transfer data required for automatic mixing functions. In order to understand the power and functions available with this architecture it is helpful to think of them as entities separate from the hardware.

In this sense a DM processor is simply a hardware-based tap into the digital matrix via the DANI bus to interface various types of microphones and audio equipment with the digital matrix. Thus connected, the processors distribute audio signals and share information about each input and output to provide a myriad of features and functions.

When multiple DM processors are stacked, each unit participates with the digital structure in several ways:

- Delivering audio signals from its input terminals into the forward-propagated submix bus
- Passing back-propagated final mix signals from the unit above it to the next unit below it
- Applying gain and signal processing to the audio signals at its input terminals
- Delivering audio signals to its output terminals as selected by the setup
- Applying signal processing to the signals routed to its output terminals
- Receiving and transmitting data required for the automatic mixing process in the matrix

The digital matrix is common to all processors in the stack, with automatic mixing taking place at the crosspoints in the digital matrix. The output of each crosspoint is then available at a variety of output terminals on various processors in the stack.

Different processor models interface with the digital matrix in different manners. Audio signals and data are propagated from the Slaves to the Master unit in a stack, then the data and some of the final mix signals in the Master are back propagated to the Slaves. This provides additional final mix outputs at the output terminals on the Slave units.

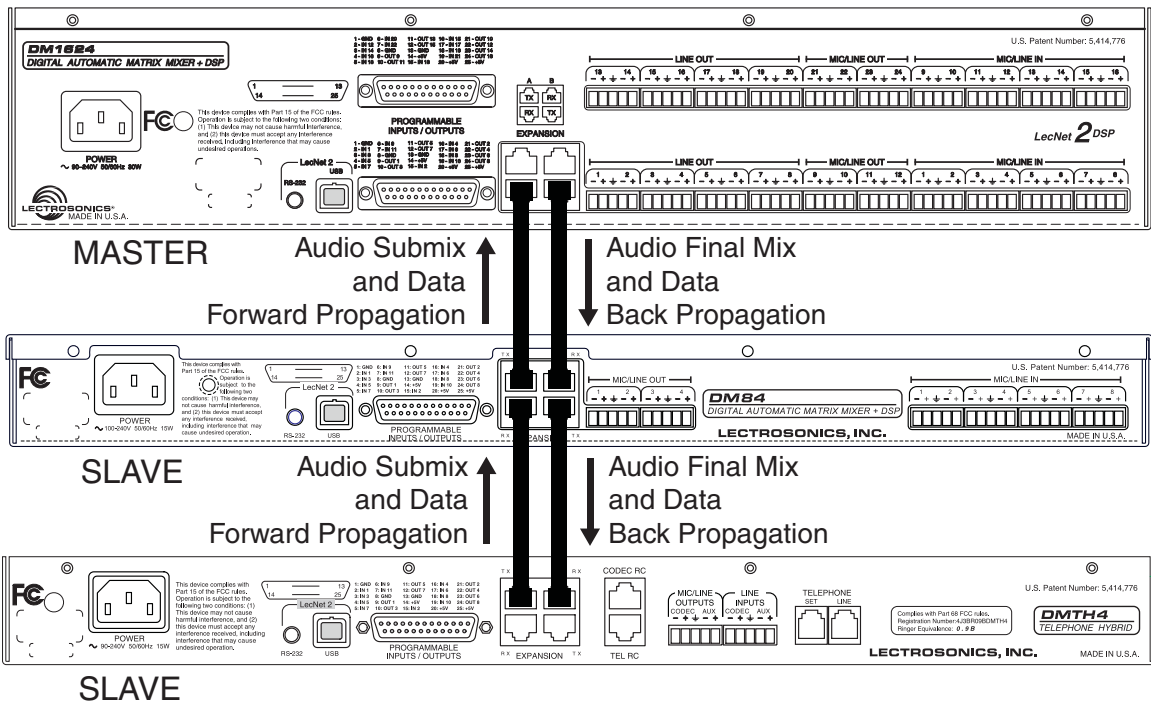
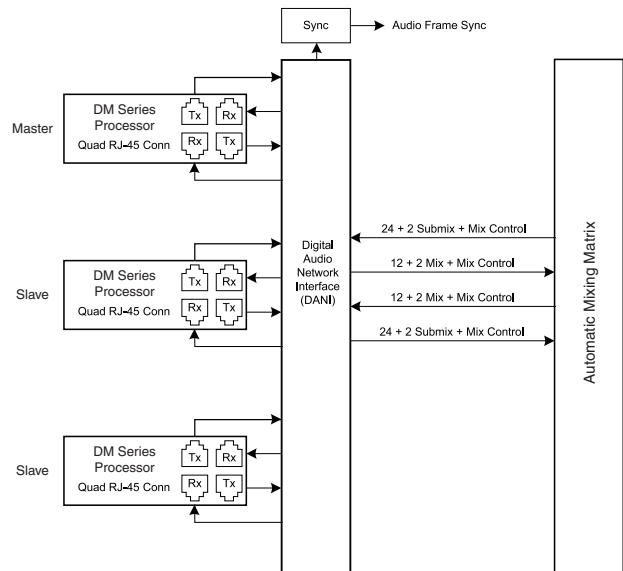

## Hardware Control

The DM84 processor has programmable inputs which can be used to control a wide variety of functions. Depending on the function assigned to them, these programmable inputs may be connected to momentary contact switches, toggle switches, or potentiometers. When used with a switch, the inputs are activated by connecting them to ground through the switch contacts, called a “contact closure.” When used with a variable resistor, the inputs respond to the applied voltage in the range 0 to 5 VDC.

Another feature of the rear panel control interface are a set of programmable outputs which can be set up to indicate either audio input channel activity or programmable input status. Programmable outputs act as an electronic “contact closure” to ground. When the output is active, the contact is closed (conducting to ground). When the output is inactive, the contact is open (not conducting to ground).

An important application of the rear panel control interface is to manage what is called the rear panel gain for input and output audio channels. This is an additional gain value that is added to the “main” gain value for a channel to give the total gain applied. Rear panel gain is limited to the range -60dB to 0dB, and therefore is actually intended to function as a variable attenuator for the audio channel. The purpose is to allow some amount of gain or level control by the end user in a safe manner, using one of the programmable inputs.

A typical application of rear panel gain is to allow adjustment of the level of an audio output (driving a speaker) downward from some maximum by means of turning a potentiometer connected to a programmable input which has been set up to use the Analog Output RP Gain Control function.

Complete details on the use of Rear Panel control is provided in the Installation Guide and in the Control Panel GUI provided with the unit.

## Command Language

A very powerful, yet intuitive command language allows complete control over DM Series processors with short commands delivered via the USB or RS-232 ports. The language and structure makes programming remote control functions very easy. Individual function settings and signal routing can be customized for a particular application during setup, recalled from various screens during operation, or recalled by other brands of remote control systems. The RS-232 serial port is completely compatible with control systems from AMX®, Crestron® and with Extron® IPL Series ethernet adapters which allow remote control via standard networks. A complete library and explanation of the commands and the command structure is available in the DM84 Reference Manual.

*AMX, Crestron and Extron are registered trademarks of the respective companies.*

## Macros

A comprehensive macro utility greatly expands the remote control capability. The DM84 can be remotely controlled using commands sent over USB, a serial port, or a network connection. An extensive text-based command language is defined for the DM84. Touch panel controllers, for instance, use this command interface.

Macros are predefined groups of commands that are stored internally by the DM84. All of the commands contained in the macro can then be executed by issuing a single Run command to the DM84. There are two advantages to this approach:

- Efficiency - only one command needs to be sent to the DM to execute complex actions, which may involve dozens of individual commands.
- Modularity - frequently executed sequences can be implemented as a macro which can be reused in other control designs, or combined with other macros to form complex actions.

Up to 128 macros can be stored in the DM84 nonvolatile memory. Macros are global in scope, meaning that they are not associated with any particular preset. Each macro can contain up to 64 commands, with 115 characters in each command. Macros may be given a descriptive title which is stored along with the command list.

Macros can be chained if necessary, meaning that one macro can call another macro by virtue of containing a run command. A run command issued from within a macro will be delayed until after the first macro has finished running. In other words, macros aren't nested, they always run sequentially (chaining). The best practice when chaining macros is to make the run command the last command in a macro.

The control panel contains a Macro Editor which is used to create new macros or edit existing ones when the PC is connected to a DM. Macros may also be opened and saved as files, making it possible to work with them in offline mode as well.

The control panel also contains a Macro Recorder which allows a sequence of commands to be captured as a macro without typing them into the Macro Editor. The Macro Recorder works by capturing the commands generated by the control panel when the mouse and keyboard are used to make changes to the DM84 settings. The macro recorder can run while connected to a DM or used in offline mode to create command sets in advance of the installation.

## Front Panel



The DM84 is housed in a single space 19" rack mount assembly. The front panel provides input and output level controls to make adjustments manually while the system is operating. Multi-color LEDs indicate activity on each input and output channel. A Mode switch allows booting the unit as a Master when it is configured as a Slave and powered up by itself.

The Status LED indicates steadily in normal operation and blinks in the presence of several different errors. A USB port on the front panel allows easy access for setup or troubleshooting from the front side of the rack. The power switch is a rocker type with positive action.

## Rear Panel

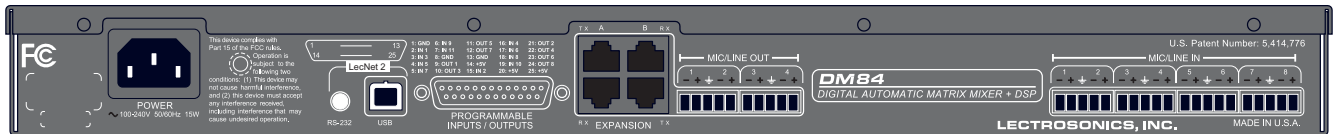

A universal 100-240 VAC power supply with a standard AC receptacle is provided on the rear panel. The USB and RS-232 jacks are used for computerized setup, firmware updates and to control systems during operation. Logic input and output connections are made via a DB-25 jack.

RJ-45 jacks interface with other DM Series components via the DANI bus. The balanced differential inputs and outputs are paired on standard depluggable connectors sharing a ground to reduce the amount of wiring needed.

## Specifications

### Audio inputs

Gain: -10 dB to +60 dB; programmable 1 dB steps  
 Input impedance: 2.5 k Ohm  
 Phantom voltage: 15V, programmable  
 Connector: 5-pin Phoenix

### Audio outputs:

Floating balanced, either side can be grounded  
 Nominal level: 0 dBu all outputs, -40 dBu selectable on outputs 9 through 12  
 Output impedance:  
 • 450 Ohm differential programmable outputs at line level  
 • 5 Ohm differential programmable outputs at microphone level

**Input Dynamic Range:** 96 dB at -50 dBu input level; 102 dB at all other levels (unweighted 20 - 20 kHz)

**Output Dynamic Range:** 105 dB (unweighted 20 - 20 kHz)

### Audio Performance:

IMD + noise: 0.1% max.  
 0.02% nominal input level  
 THD + noise: 0.1% (worst case)  
 0.02% nominal input level  
 EIN: -126 dBu

### Connectors:

Audio I/O: 5-pin Phoenix  
 Expansion: RJ45  
 Logic I/O: DB25  
 Serial: Standard USB and mini TRS

### Digital Audio Network Interface ( DANI):

Physical level: LVDS (Low Voltage Differential Signal) high speed  
 Connector: Four RJ-45  
 Cable quality: Shielded CAT-5  
 Transmission speed: 50 Mbits/s

### Programmable control inputs

Number of inputs: 11  
 Analog voltage range: 0-5V  
 Logic input: TTL, LVTTTL, CMOS, LVCMOS

### Programmable control outputs

Number of logic outputs: 8  
 Logic control: Active low  
 Max sink current: 100 mA  
 Max supply voltage: 40 V  
 Supply voltage for control I/O: 5 V  
 Max current: 750 mA

**Power requirements:** 100-240 VAC, 47-63 Hz

**Power consumption:** 15 Watts



581 Laser Road NE • Rio Rancho, NM 87124 USA • [www.lectrosonics.com](http://www.lectrosonics.com)  
 (505) 892-4501 • (800) 821-1121 • fax (505) 892-6243 • [sales@lectrosonics.com](mailto:sales@lectrosonics.com)

DM84TD - 20 July 2006