



Quam

CIS4/xx

2-Gang, Vandal Resistant Call-In Station, Stainless Steel

CIS2/xx

3-Gang, Vandal Resistant Call-In Station, Stainless Steel

0602 - VANDAL RESISTANT INTERCOM ASSEMBLIES

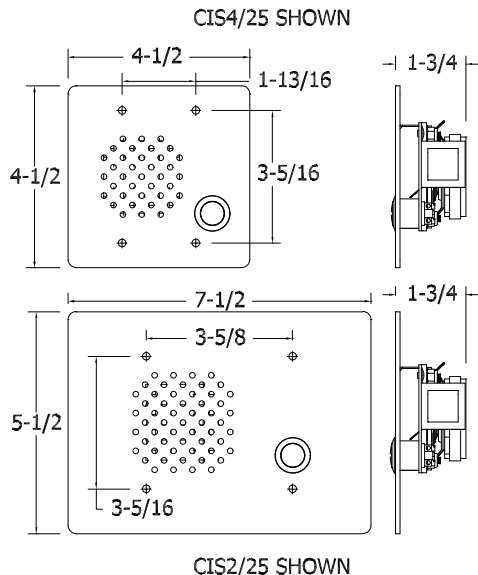

CIS4/x SHOWN

GENERAL DESCRIPTION - All variants

The Quam CISx/xx is a complete vandal-resistant call-in station with integral speaker/microphone and momentary, normally open, push-to-call button. The faceplate is 12 gage, brushed stainless steel with tamper-resistant, #6-32 'pin-in-hex' hardware. An optional, red mushroom button can be substituted at extra cost at the time of order.

The Quam CIS4/xx, as above in 2-gang wide format
 The Quam CIS2/xx, as above in 3-gang wide format

Specify at time of order, one of following:
 8 or 45 Ohm impedance voice coil -or-
 25V multi-tap transformer

Other transformer options available, please contact Factory

INTENDED USE: All variants

Outdoor or indoor environment.
 Program material: Signal tones and voice

SYSTEM COMPONENTS

Loudspeaker	3" weatherproof (CIS2 format) 2-1/2" weatherproof (CIS4 format) Phenolic impregnated cone
Transformer Option: 25V	1W, 3 taps at -3 db levels Order CISx/25
Voice Coil Options: 8 Ω 45 Ω	Order CISx/8 Order CISx/45

RECOMMENDED ADDITIONAL QUAM COMPONENTS

CIS2/xx only:
 0603 SE3GVP Vandal Resistant Surface Mount Enclosure

CIS4/xx only:
 0603 SE6GVP Surface Mount Enclosure
 0603 SE7GVP Hooded Surface Mount Enclosure
 0603 SE8GVP Angled Surface Mount Enclosure

AUDIO SPECIFICATIONS

Speaker Size	3" - CIS2/xx, 2-1/2" - CIS4/xx
Average Sensitivity	87 dB-SPL, 1W / 1M
Power rating	1W RMS, EIA 426A Standard
Frequency Response	150 - 10 kHz, CIS6 200 - 8 kHz, CIS8 EIA 426A Standard
Nominal Coverage Angle	90° Included Angle
Coverage Angle	-6 dB / 2 kHz, half space
Audio Connections	Transformer: 7" long, color-coded tinned wires, Pre-cut 8Ω / 45Ω Speaker: 0.205 spade lug

Recommended construction sequences, installation instructions and A&E Specifications are available in various formats on the Quam Architects' and Engineers' Resources CD or on the web at: www.quamspeakers.com

CORRECTION / DETENTION

06

Quam-Nichols Company

234 East Marquette Road, Chicago, IL 60637
 Phone: (800) NEED NOW Fax: (888) NEED NOW
 (800) 633 - 3669 (888) 633 - 3669
 E-Mail: neednow@qnc.com www.quamspeakers.com

