



Quam



QC 100 Series
0501-Attenuators
0501.1- Attenuators, UL Listed

0501, 0501.1 - ATTENUATORS

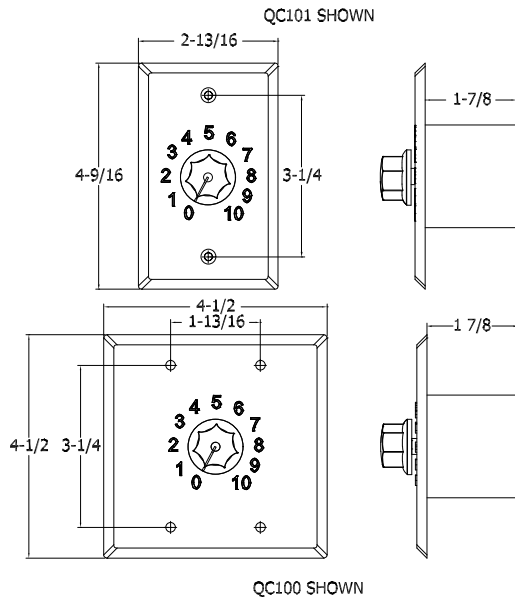

GENERAL DESCRIPTION

The Quam QC100xx is a dual gang, continuous rotary ten-step audio level attenuator with an OFF position.

The Quam QC101xx is a single gang, continuous rotary ten-step audio level attenuator with an OFF position.

Both single gang and dual gang formats are available in: -P (Priority relay), -RM (Rack Mount) and -W (White finish) formats described below.

All variants except the QC10xP are UL Listed 813.

Finish: QC10x, QC10xP- Brushed stainless steel, embossed position

QC10xRM- 2" x 2" dial scale, white on black

QC10xW- White baked hybrid epoxy finish, no position on scale

Knob: QC10x, QC10xP, QC10xRM- Black with white indicator

QC10xW- White molded indicator

INTENDED USE

QC10x, QC10xRM, QC10xW:

Attenuates audio power to any number of loudspeakers up to 100W load. For use with 25V or 70.7V distributed audio systems, indoor environment. UL Listed 813

QC10xP: (No UL Listing)

Attenuates audio power to any number of loudspeakers up to 100W load. For use with 25V or 70.7V distributed audio systems, indoor environment. When internal 24VDC relay is activated, attenuator function is bypassed.

SYSTEM COMPONENTS

N/A

RECOMMENDED ADDITIONAL QUAM COMPONENTS

0403- Surface Mounting Devices

SE4W/2 Double Gang Box- QC100 Only

SE4W Single Gang Box- QC101 Only

AUDIO SPECIFICATIONS

Power Rating	100W Continuous
Attenuation	Steps 1-2, -3 dB
(Ref: 25, 70.7, and 100V line)	Steps 3-10, -1.5 dB
	OFF Position, -36 dB
Insertion Loss	< 0.5 dB

MECHANICAL SPECIFICATIONS

Mounting	QC100, QC100W, QC100P: Dual Gang electrical box, 2-3/4" deep
	QC101, QC101W: Single Gang electrical box, 2-3/4" deep
	QC101P: Single Gang electrical box, 3-1/2" deep
	QC10xRM: 2RU rack panel or greater, 1/8" thick maximum
Relay Actuation	24VDC, 0.15A (QC100P only)
Audio Connection	10" long, color-coded tinned wires, pre-cut

Recommended construction sequences, installation instructions and A&E Specifications are available in various formats on the Quam Architects' and Engineers' Resources CD or on the web at: www.quamspeakers.com

ATTENUATORS

05

Quam-Nichols Company

234 East Marquette Road, Chicago, IL 60637

Phone: (800) NEED NOW Fax: (888) NEED NOW

(800) 633 - 3669 (888) 633 - 3669

E-Mail: neednow@qnc.com www.quamspeakers.com