

Set 820 s

Bedienungsanleitung
Instructions for use
Notice d'emploi
Instrucciones para el uso

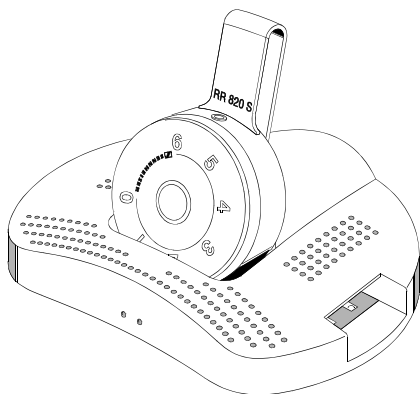

Set 820 S

The Set 820 S is an assistive listening system for your radio, TV, hi-fi system or similar sound sources at the volume you choose.

The transmitter has a range of up to 100 ft which allows you to move around freely – without the constrictions of cables. The system uses RF audio signals for sound transmission.

The RR 820 S is an RF stereo receiver which features an audio socket for connecting a pair of headphones, induction accessories or hearing aids with audio input. The RR 820 S receives music and speech via wireless transmission from a TR 820 RF stereo transmitter.

The EZT 1011 induction neck loop inductively transmits the audio signal from the receiver to hearing aids in T-position.

SWARNING:



Volume up? - No!

When people use headphones, they tend to choose a higher volume than with loudspeakers. However, if your hearing has deteriorated and you need to rely on an assistive listening system, please avoid listening at high volume levels for a long time. Please protect your hearing.

ATTENTION:



Danger of short circuit!

Neither transmitter nor receiver must get wet or excessively moist, e.g. due to spilled liquids or use in damp rooms.

ATTENTION:



Components from other manufacturers (e.g. for power supply or battery) may cause damage to the unit and will invalidate the warranty.

This advice complies with Part 15 of the FCC Rules and with RSS-210 of Industry Canada. Operations is subject to the following two conditions:
(1) this device may not cause harmful interference, and
(2) this device must accept any interference received, including interference that may cause undesired operation.

FCC ID: DMOUSC820

IC: 2099A-USC820

Contents

The Set 820 S consists of the following components and accessories:

- Receiver RR 820 S
- Transmitter TR 820 (charging unit)
- Rechargeable battery BA 151
- Power supply NT 820
- Microphone MKE 800 TV
- Connecting cable for headphone output
- Adapter for RCA socket
- Instruction manual
- Quick Instructions

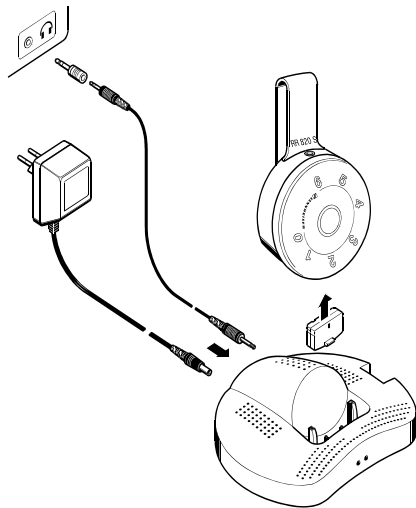
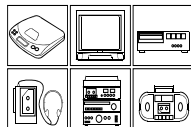

Connecting the transmitter (charging unit)

The rear of the transmitter is fitted with two audio inputs: A socket (LINE) for connection to the LINE OUT socket or the headphone socket on your TV, and a microphone socket (MIC).

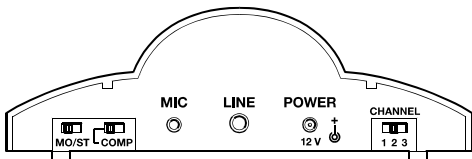

Plug in one end of the connecting cable to the LINE OUT socket or the headphone socket on your TV, and the other end to the LINE socket on the transmitter.

If your TV does not have a headphone or RCA socket, you can use an external microphone which is described in the section "Accessories".

Only use one of the two audio inputs on the transmitter (MIC or LINE).

Connect the power cable to the POWER socket on the transmitter. Plug the power supply into a household electrical outlet.

Pull the power supply unit out of the electrical outlet when the unit will not be used for extended periods of time.

Complete freedom of movement

It is not necessary that the transmitter and receiver are in a direct line of sight, so you can move around freely in the home or outside in the garden. One transmitter can be used to transmit to several receivers on the same frequency. The transmitter's range may decrease due to the surface/composition of walls.

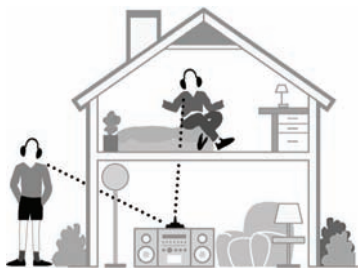

Where to place the transmitter

Choose a suitable place near or on top of your hi-fi system or TV set.

Do not place the transmitter close to metal objects such as shelf bars, reinforced concrete walls, etc.

The transmitter features a convenient automatic on/off function. The transmitter is turned on by the audio signal.

If there is no audio signal for about 3 minutes, the transmitter automatically turns off. The transmitter is now in stand-by mode, its power consumption is very low so that it can remain connected to the mains. Batteries can always be recharged when the transmitter is connected to the mains.

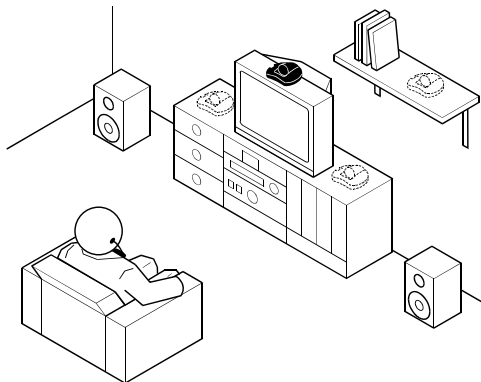

Using the receiver

The receiver is turned on automatically as soon as a 3.5 mm stereo jack plug is inserted into the socket at the top of the receiver.

Affix the receiver to the clothing by means of its integrated attachment clip.

Using the induction neck loop

Put the EZT 1011 induction neck loop around your neck and insert its plug into the socket at the top of the receiver. Set your hearing aid to position "T".

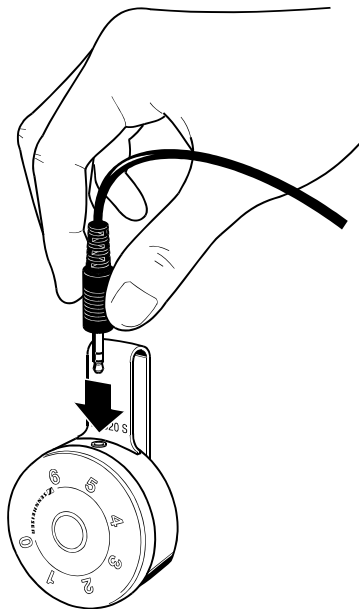

Adjusting the volume

Adjust the receiver's volume with the operating control.

If you are not using the receiver, pull the 3.5 mm stereo jack plug out of the receiver's socket to avoid discharging the battery. The receiver is then turned off.

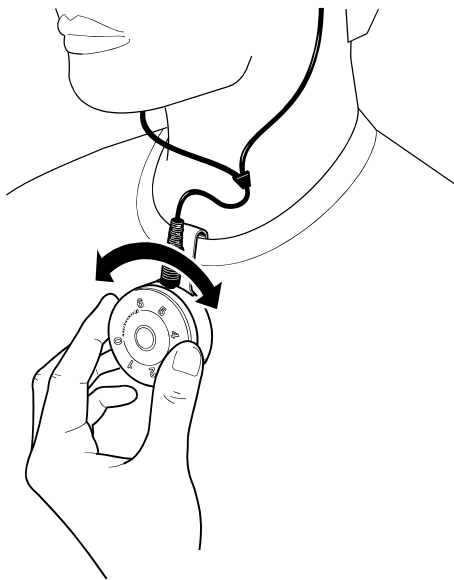

Changing the transmission channel

To avoid interference caused by the simultaneous operation of several transmitters, select a different channel on each transmitter. To select a channel, set the CHANNEL switch at the rear of the transmitter to the desired position. Due

to restrictions on frequency usage, only two channels are available:
Position 1 or 3 = channel 1 Position 2 = channel 2

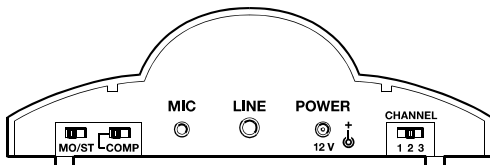

Turning the automatic compression system on

Use the COMP switch (compression) at the rear to turn the automatic compression system on. This system reproduces soft passages louder and decreases loud sounds. Choose the setting that suits your listening preferences.

Use the MO/ST switch to choose between mono and stereo transmission. For mono TVs and when using the MKE 800 TV microphone, the switch must be set to MONO (MO).

Adjusting the receiver channel

First turn on the transmitter (see section “Where to place the transmitter”).

As soon as the receiver is turned on, it automatically tunes itself to the first strong signal found (normally the transmitter frequency). If, for some reason, the selected channel is not the correct one (e.g. because of interference or another nearby system), press the TUNE button at the rear of the receiver until you can hear the audio signal loud and clear. If

you decide to change the transmitter channel (see section “Changing the transmission channel”), the frequency search tuning must be re-started by pressing the TUNE button on the receiver again.

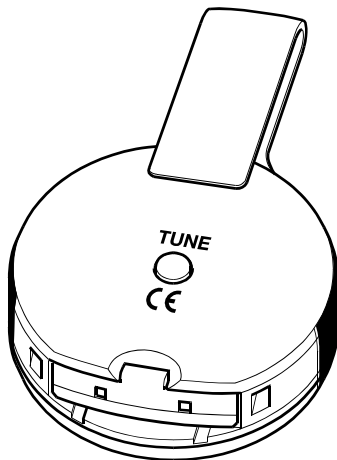

Charging the battery

Place the receiver into the transmitter's charging compartment, with the operating control at the front. Pull the 3.5 mm stereo plug out of the receiver to turn the receiver off. The left LED on the transmitter must light up.

Charge the battery for 24 hours before you use it for the first time. The normal charging time is 4-5 hours. A fully charged battery has an operating time of approx. 4 hours. When charging a spare battery in the small charging compartment at the right of the transmitter, charging time is 10-12 hours.

The transmitter automatically switches to trickle charging so that the battery cannot be overcharged. The receiver can remain in the charging compartment even when the battery has been fully charged.

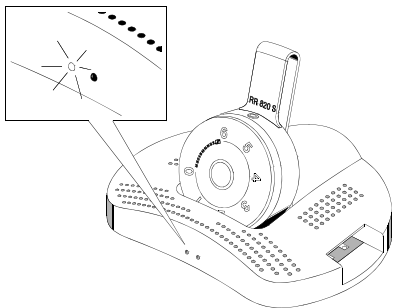

A battery has a service life of 1-2 years and should be replaced if the operating time decreases.

Sennheiser batteries can be recycled. Please dispose of the batteries as special waste or return them to your specialist dealer. To protect the environment, only dispose of totally exhausted batteries which cannot be recharged.

Additional information

The audio transmission technology used with this unit is basically that of a radio. According to today's scientific knowledge, the radio waves emitted by this unit are not harmful to humans or animals.

Varnish or furniture polish may degrade the rubber feet of the transmitter. Place the transmitter on a nonslip pad to avoid potential staining of furniture.

Use a soft cloth for cleaning the units. Do not use abrasive cleaners.

Accessories

Only use original Sennheiser spare parts and accessories.

The following accessories are available from your authorized dealer:

Rechargeable battery	BA 151
Charger	L 151-2
Additional receiver	RR 820 S
External microphone	MKE 800 TV
Induction loop	EZT 1011
Dynamic headphones	HD 25 SP
HZL series connecting cable (for direct connection to hearing aids)	

BA 151 rechargeable battery

By using a spare battery, you can use the receiver for more than four hours of continuous operation. Always store the spare battery in the small charging compartment at the right of the transmitter. The right LED on the transmitter lights up green to show charging is taking place. When charging a battery in the small charging compartment, the charging time is 10-12 hours.

L 151-2 charger

Spare batteries can be charged via the L 151-2 charger.

RR 820 S receiver

One transmitter can transmit to several receivers. Additional RR 820 S receivers are available from your authorized dealer.

MKE 800 TV external microphone

If your TV doesn't have a headphone output or RCA socket, you can use your Set 820 S-9 together with the MKE 800 TV microphone.

Fix the microphone to the loudspeaker of your TV by means of Velcro tape. Connect the microphone connector to the MIC socket on the transmitter and set the transmitter's MO/ST switch to MONO (MO).

HD 25 SP dynamic headphones

Closed dynamic headphones for connection to the RR 820 S.

Any dynamic headphones with a 3.5 mm stereo jack plug and a minimum impedance of 32 ohms can be connected to the RR 820 S receiver.

EZT 1011 induction loop

Induction loop for inductive audio transmission to hearing aids.

If problems occur...

- Are all jack plugs connected correctly?
- Are the receiver and sound source turned on and is the volume of the receiver and sound source sufficient?
- Is the rechargeable battery inserted properly into the receiver?
- Have you charged the rechargeable battery for at least 20 minutes?
- Are you too far from the transmitter? (if so, move closer)
- Choose a different channel.
- Adjust the setting with the TUNE button.
- Should the problem persist, please contact your authorized dealer for assistance.



Never open the unit!

Additional information for hearing aid acousticians

Adjustments for hearing disabilities

Attention:

In order to ensure interference-free reception, only use the potentiometers shown below.

Turn the operating control fully to the left (0). Remove the operating control by carefully lifting it over the "guide notch" on the inside. Use the 4 potentiometers on the circuit board to individually adjust the max. volume and the bass response for the left and right headphone system.

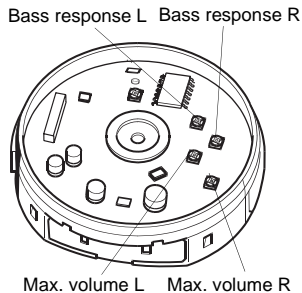

Adjusting the max. volume:

Potentiometer turned fully to the left
Potentiometer turned fully to the right

min.
max.

Adjusting the bass response:

Potentiometer turned fully to the left
Potentiometer turned fully to the right

attenuation of 25 dB at 100 Hz
attenuation 0 dB

The adjustments can also be made when the receiver is being used.

When replacing the operating control, make sure the "projections" on the inside of the operating control point in the direction of the attachment clip.

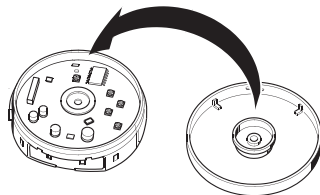

After replacing the operating control, synchronize the operating control with the volume control by once turning it fully in both directions.

Specifications

System

Modulation	FM, stereo
Carrier frequencies	see type plate at the base of the transmitter
AF frequency response	40 Hz 15 kHz
S/N ratio	60 dB A rms

Transmitter

RF output power	typ. up to 0,75 mW
AF input voltage range	50 mV 5 V
Audio input	0,14 inch jack, stereo/mono
Microphone socket	0,1 inch jack, mono
Charging time for battery	approx. 4 h

Charging time (spare battery)	approx. 10-12 h
Power supply	12 V DC via NT 820 mains unit
Power consumption	typ. 55...89 mA, depending on batterie charge state
Weight	approx. 94 g (without battery)
Dimensions	diameter: 5.9 inch, height: 1.9 inch

Receiver

AF frequency response	40 Hz 15 kHz
S/N ratio	60 dB A rms
Power supply	2.4 V via BA 151 battery
Power consumption	typ. 20 mA
Operating time	approx. 4 hours per battery
Weight	approx. 35 g (without battery)
Dimensions	length: 3.7 inch, width: 2.5 inch, height: 1.4 inch
Output voltage	max. 700 mV at 32 Ω

Induction loop

AF frequency response	300 10,000 Hz
Impedance	47 Ω
Magnetic field strength at the hearing aid	100 mA/m at 1 kHz and 10 mVA

Guarantee	2 years
-----------	---------

Manufacturer declarations

CE Declaration of Conformity

This equipment is in compliance with the essential requirements and other relevant provisions of Directives 1999/5/EC, 89/336/EC or 73/23/EC. The declaration is available on the internet site at www.sennheiser.com.

Before putting the device into operation, please observe the respective country-specific regulations!

WEEE Declaration



Your Sennheiser product was developed and manufactured with high quality materials and components which can be recycled and/or reused. This symbol indicates that electrical and electronic equipment must be disposed of separately from normal waste at the end of its operational lifetime.

Please dispose of this product by bringing it to your local collection point or recycling centre for such equipment. This will help to protect the environment in which we all live.

Batteries



The supplied rechargeable batteries can be recycled. Please dispose of rechargeable batteries as special waste or return them to your specialist dealer. In order to protect the environment, only dispose of exhausted batteries.



Sennheiser electronic GmbH & Co.KG
30900 Wedemark, Germany
Phone +49 (5130) 600 0
Fax +49 (5130) 600 300
www.sennheiser.com
Printed in Germany

Publ. 02/06

515833 / A01