

527E Voice Processor

527E



User's Guide

Table of Contents

<i>Chapter 1</i>	Introduction	1
<i>Chapter 2</i>	Operator Safety Summary	2
<i>Chapter 3</i>	Fast Setup	3
<i>Chapter 4</i>	Front Panel Overview	5
<i>Chapter 5</i>	Rear Panel Overview	7
<i>Chapter 6</i>	Using the 527E	8
<i>Chapter 7</i>	Applications	11
<i>Chapter 8</i>	Troubleshooting	13
<i>Chapter 9</i>	Specifications	14
<i>Chapter 10</i>	Block Diagram	16
<i>Chapter 11</i>	Warranty & Service	17
<i>Appendix A</i>	Declaration of Conformity	19

Rev A.00, 1 September, 1999

Symetrix part number 53527-0A00

Subject to change without notice.

©1999, Symetrix, Inc. All right reserved.

Symetrix is a registered trademark of Symetrix, Inc.

Mention of third-party products is for informational purposes only and constitutes neither an endorsement nor a recommendation. Symetrix assumes no responsibility with regard to the performance or use of these products.

Under copyright laws, no part of this manual may be reproduced or transmitted in any form or by any means, electronic or mechanical, including photocopying, scanning, recording or by any information storage and retrieval system, without permission, in writing, from Symetrix, Inc.

 **Symetrix**

14926 35th Ave. West
Lynnwood, WA 98037 USA

Tel (425) 787-3222

Fax (425) 787-3211

Email: symetrix@symetrixaudio.com

527E

 **Symetrix**

The Symetrix 527E traces its heritage back to the Symetrix 528, the first signal processor specifically designed for voice applications. Revered as the rackmount equivalent of a studio console strip, the classic 528E is still the most widely-used voice processor in the broadcast industry. To this benchmark design, we added new controls and connections, and we refined it according to the needs of installed sound applications. The result: An ideal product for installations requiring great sounding key microphones. When used on announcement mics in stadiums and gymnasiums, wireless and lapel mics in church systems, and paging mics in acoustically challenging environments, the 527E provides voice-optimized processing from the company that invented it.

Simply stated, the 527E consists of a high-quality microphone preamp coupled to a three-band parametric equalizer, high and low pass filters, and a dynamic range processor.

The dynamic range processor combines an interactive compressor/limiter and a downward expander. Typically, the downward expander helps reduce background noise as well as the artifacts of close miking. The compressor/limiter gives you overall control over the dynamic range of the output signal and helps maintain a high overall signal level.

The filter section of the 527E features tunable low cut and high cut filters. These 12 db per octave filters allow the user to remove objectionable low frequency noises, such as rumble and muddiness, and high frequency noises, such as sibilance and air conditioning noise.

The three-band parametric equalizer is a reciprocal-curve design. Each band is connected in series with the next to ensure that each filter band sums with its neighbors smoothly.

The 527E accepts both mic and line inputs. The microphone input uses a balanced transformerless design. It works with any phantom-powered condenser microphone or any low-impedance microphone having a balanced, floating output. The line input also uses a balanced transformerless design and its matched resistors permit the 527E to attain a high, wideband, CMRR (common-mode rejection ratio). Multistage RFI filters prevent radio frequency interference problems. The 527E's output section can drive balanced loads at line or mic levels.

We recommend that you read this manual from cover to cover. Somewhere between the confines of the two covers you should find the answers to most (98%) of your questions. Should you have any comments or questions, please do not hesitate to contact us at the numbers/addresses below. Your calls are always welcome.

Phone: (425)787-3222

Fax: (425)787-3211

Email: symetrix@symetrixaudio.com

Website: www.symetrixaudio.com

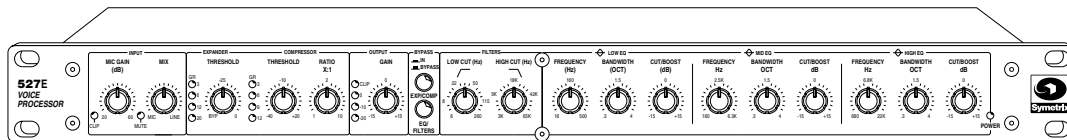

Front panel

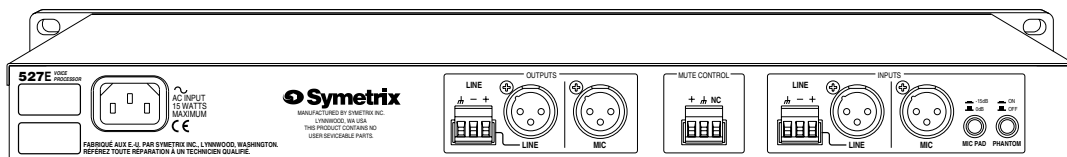

Rear panel

527E



Equipment Markings

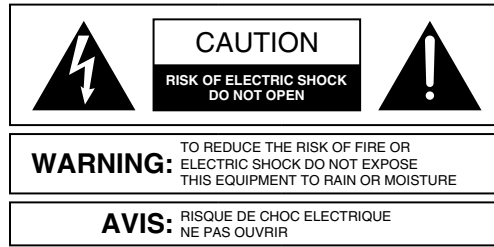

SEE OWNERS MANUAL. VOIR CAHIER D'INSTRUCTIONS.
 No user serviceable parts inside. Refer servicing to qualified service personnel.
 Il ne se trouve à l'intérieur aucune pièce pouvant être réparée l'utilisateur.
 S'adresser à un réparateur compétent.

The lightning flash with arrowhead symbol within an equilateral triangle is intended to alert the user of the presence of uninsulated “dangerous voltage” within the product's enclosure that may be of sufficient magnitude to constitute a risk of electric shock to persons. The exclamation point within an equilateral triangle is intended to alert the user of the presence of important operating and maintenance (servicing) instructions in the literature accompanying the product (i.e. this manual).

Caution *To prevent electric shock, do not use the polarized plug supplied with the unit with any extension cord, receptacle, or other outlet unless the blades can be fully inserted.*

Terms

Several notational conventions are used in this manual. Some paragraphs may use **Note**, **Caution**, or **Warning** as a heading. Certain typefaces and capitalization are used to identify certain words. These are:

- Note** Identifies information that needs extra emphasis. A **Note** generally supplies extra information to help you to better use the 527E.
- Caution** Identifies information that, if not heeded, may cause damage to the 527E or other equipment in your system.
- Warning** Identifies information that, if ignored, may be hazardous to your health or that of others.
- CAPITALS** Controls, switches or other markings on the 527E's chassis.
- Boldface** Strong emphasis.

Important Safety Instructions

Please read and keep these instructions. Heed and follow all warnings and instructions. Install in accordance with the manufacturer's instructions.

Power Source This product is intended to operate from a power source that does not apply more than 120V rms between the power supply conductors or between either power supply conductor and ground. A protective ground

connection, by way of the grounding conductor in the power cord, is essential for safe operation.

Grounding The chassis of this product is grounded through the grounding conductor of the power cord. To avoid electric shock, plug the power cord into a properly wired receptacle before making any connections to the product. A protective ground connection, by way of the grounding conductor in the power cord, is essential for safe operation. **Do not defeat the safety purpose of the grounding plug.** The grounding plug has two blades and a third grounding prong. The third prong is provided for your safety. When the provided plug does not fit your outlet, consult an electrician for replacement of the obsolete outlet.

Danger from Loss of Ground If the protective ground connection is lost, all accessible conductive parts, including knobs and controls that may appear to be insulated, can render an electric shock.

Proper Power Cord Use only the power cord and connector specified for the product and your operating locale. Use only a cord that is in good condition. **Protect the power cord** from being walked on or pinched, particularly at plugs, convenience receptacles, and the point where they exit from the apparatus.

Operating Location Do not operate this equipment under any of the following conditions: explosive atmospheres, in wet locations, in inclement weather, improper or unknown AC mains voltage, or if improperly fused. Do not install near any heat source such as radiators, heat registers, stoves, or other apparatus (including amplifiers) that produce heat. Unplug this apparatus during lightning storms or when unused for long periods of time.

Stay Out of the Box To avoid personal injury (or worse), do not remove the product covers or panels. Do not operate the product without the covers and panels properly installed. Only use accessories specified by the manufacturer. Clean only with a damp cloth.

User-serviceable parts There are no user serviceable parts inside the 527E. In case of failure, refer all servicing to the factory. Servicing is required when the 527E has been damaged in any way, such as when a power supply cord or plug is damaged, liquid has been spilled or objects have fallen into the apparatus, the apparatus has been exposed to rain or moisture, does not operate normally, or has been dropped.

527E

Fast Setup

Follow these instructions to get your 527E up-and-running as quickly as possible. The intent of this section is fast setup. If you need something clarified, then you'll find the answer elsewhere in this manual.

Connections

Connect your input source to the appropriate XLR or Euroblock connector. Connect the 527E's output to line-level input using the line-level XLR or Euroblock output connector. If you need to feed a mic-level input, use the mic-level XLR output connector.

If you are using a condenser microphone, refer to "Phantom Powering Condenser Microphones" in Chapter 6 before depressing the PHANTOM POWER switch.

Caution *Failure to connect the 527E to the proper AC mains voltage may cause fire and/or internal damage. There are no user serviceable parts inside the chassis. Refer all service to qualified service personnel or to the factory.*

Warning **Lethal voltages are present inside the chassis. There are no user serviceable parts inside the chassis. Refer all service to qualified service personnel or to the factory.**

Connect the AC input to an AC power source of the proper voltage and frequency, as marked on the rear of the unit.

Settings for Initial Setup

Set the controls and switches on the front and rear panel as follows:

Front Panel Control	Setting
MIC GAIN	12 o'clock
MIX	12 o'clock
Expander THRESHOLD	0 (max CW)
Compressor Threshold	-10 (12 o'clock)
Compressor RATIO	2:1 (12: o'clock)
GAIN	0 (12 o'clock)
BYPASS EXP/COMP	IN
BYPASS EQ/FILTERS	IN
LOW CUT	22 (10 o'clock)
HIGH CUT	18K (3 o'clock)

Front Panel Control	Setting
EQ Low FREQUENCY	160 (12 o'clock)
EQ Low BANDWIDTH	1.5 octaves (12 o'clock)
EQ Low CUT/BOOST	0 (12 o'clock)
EQ Mid FREQUENCY	2.5K (12 o'clock)
EQ Mid BANDWIDTH	1.5 octaves (12 o'clock)
EQ Mid CUT/BOOST	0 (12 o'clock)
EQ High FREQUENCY	2.5K (11 o'clock)
EQ High BANDWIDTH	1.5 octaves (12 o'clock)
EQ High CUT/BOOST	0 (12 o'clock)



The 527E's controls and switches are now set according to the preceding section. The 527E should now pass signal. The **OUTPUT LEVEL LED** display and the **POWER LED** should be illuminated. Depending upon the signal levels, the compressor's gain-reduction display may be illuminated.

Refining Your Settings

Temporarily put the Exp/Comp and EQ sections into bypass mode, set the **MIC GAIN** control so that the **OUTPUT LED** display indicates a signal level between -10 and 0 VU. The **CLIP LED** should almost never illuminate.

Use the downward expander to reduce background noise and/or mouth noises. Set the **THRESHOLD** control to allow low level speech sounds to pass while still blocking unwanted sounds which are at a lower level than the lowest-level speech audio.

Use the threshold control to vary the amount of gain reduction, as indicated on the compressor's gain-reduction display. Generally, 3 to 6 dB is sufficient, unless you are using a low compression ratio (below 2:1), or you want a special effect. Pick a ratio suited to the task at hand: low ratios and low thresholds for unobtrusive level control, medium ratios for overall level control and consistency, high ratios (> 8:1) for limiting or in-your-face sorts of sounds.

The frequency settings given will work well with male voices. For women, the low-EQ range shifts up to 200 or 300Hz, the mid-EQ range shifts up to 3-5 kHz.

If you are using a microphone that exhibits proximity effect when you close-talk it, then you'll probably need to reduce (cut) the bass (low) response somewhat. 3-6 dB should be fine (don't do this if you want a big, ballsy sound). A bit of mid-EQ will help make voices cut and seem loud. The high-EQ adds brightness and intimacy.

If you are using a microphone that has minimal proximity effect (like the ElectroVoice RE-20), then you'll probably need to increase (boost) the bass response somewhat. 3 to 6 dB should do the job. The same mid- and high- EQ recommendations given previously still apply.

For many applications, setting the output **GAIN** control at 0 dB (12:00 o'clock) works fine. If you are adding a bunch of EQ (which tends to cause an overall level increase), then you may need to decrease the **GAIN** setting. On the other hand, if you are using a fair amount of compression, you may need to add some gain to compensate for the level lost in compression. Pick a setting that gives you enough signal downstream, yet still keeps the **CLIP LED** from illuminating. The output display is peak responding, so you can't quite set levels as if it were a VU meter (which responds more slowly).

The output **CLIP LED** monitors the output stage. Large amounts of boost and/or high signal levels can cause **CLIP** indications. If this occurs, lower the signal level via the **GAIN** control.

Rear Panel	Setting
Output	Connect to input of console, tape recorder, etc.
Mute Control	If you wish to use the mute control, please refer to Chapter 6.
Line Input	Connect line-level source here.
Mic Input	Connect microphone here.
Mic Pad	0dB (Out)
Phantom Power	Depress if mic requires phantom powering.

527E

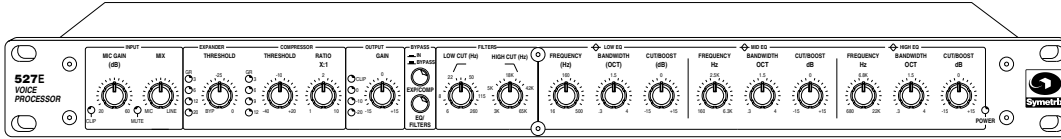

Input

- MIC GAIN** Sets the gain of the mic preamp for best compromise between signal-to-noise ratio and headroom.
- MIX** Selects between the Mic input and Line input, or allows a mix of both inputs.
- CLIP LED** Monitors mic inputs for clipping. Illuminates 3 dB below the actual clip point.
- MUTE LED** Lights when the output of the 527E has been muted by a remote switch connected to the 527E’s rear panel MUTE CONTROL Euroblock connector.

Downward Expander / Compressor

- EXPANDER THRESHOLD** Sets the threshold level for the downward expander. Signals below this threshold are downward expanded (reduced in level).
- COMPRESSOR THRESHOLD** Sets the threshold level for the compressor. Signals above this threshold cause gain reduction in the compressor.
- COMPRESSOR RATIO** Sets the compression ratio of the compressor. This determines the amount by which above-threshold signals will be compressed.
- DOWNWARD EXPANDER LED Display** Indicates the amount of downward expander activity (gain reduction) at any instant in time.
- COMPRESSOR LED Display** Indicates the amount of compressor activity (gain reduction) at any instant in time.

Output Section

- GAIN** Sets the overall gain of the 527E’s output over a ±15 dB range. The actual adjustment point is in the expander/compressor’s VCA, which is pre-EQ.
- OUTPUT LED Display** Indicates the peak output level of the 527E relative to the balanced output. 0 VU on the display corresponds to +4dBu at the balanced output. For unbalanced applications, the actual output level is 6 dB lower than that shown by the display.
- Note** The 527E’s mic output will have an output level of -36dBu when the display indicates 0 VU.

Bypass

- EXP/COMP IN/BYPASS Switch** Defeats the downward expander/compressor. This is not a hard-wire bypass.
- EQ/FILTERS IN/BYPASS Switch** Disengages the EQ and Filter section when set to the Bypass (Out) position. This is a hardwire bypass.



Filters

LOW CUT	Selects the cutoff frequency of the LOW CUT FILTER (variable from 6 Hz to 260 Hz). This filter will uniformly pass frequencies above the cutoff frequency.
HIGH CUT	Selects the cutoff frequency of the HIGH CUT FILTER (variable from 3kHz to 65 kHz). This filter will uniformly pass frequencies below the cutoff frequency.

Parametric EQ Low

FREQUENCY	Varies the center frequency of the low-frequency equalizer from 16Hz to 500 Hz.
BANDWIDTH	Varies the bandwidth of the low-frequency equalizer from 0.3 to 4 octaves. (Q=4.8 to 0.27).
CUT/BOOST	Sets the degree of boost or cut; ± 15 dB.

Parametric EQ Mid

FREQUENCY	Varies the center frequency of the mid-frequency eq from 160 Hz to 6300 Hz.
BANDWIDTH	Varies the bandwidth of the mid-frequency eq from 0.3 to 4 octaves. (Q=4.8 to 0.27).
CUT/BOOST	Sets the degree of boost or cut; ± 15 dB.

Parametric EQ High

FREQUENCY	Varies the center frequency of the equalizer from 680 Hz to 22 kHz.
BANDWIDTH	Varies the bandwidth of the high-frequency equalizer from 0.3 to 4 octaves. (Q=4.8 to 0.27).
CUT/BOOST	Sets the degree of boost or cut; ± 15 dB.
POWERLED	Indicates the presence of AC power.

527E

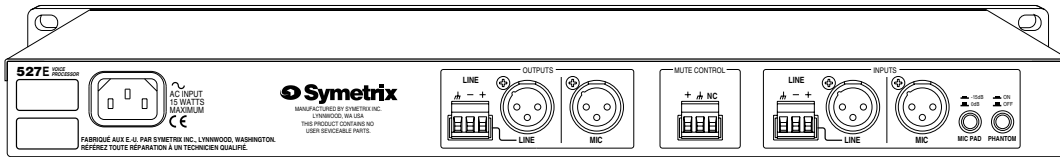

SERIAL NUMBER [Please send us the completed warranty card.]

AC POWER INPUT IEC-power connector. Connect only to appropriate AC power source. Refer to rear-panel marking for correct AC source voltage.

Outputs

LINE OUTPUT XLR connector or a Euroblock connector. Balanced, line-level output. Connections are:

<u>XLR</u>	<u>Euroblock</u>	
Pin 1	⏏	Ground
Pin 2	+	High
Pin 3	-	Low

To feed an unbalanced load, connect the Ground (shield) side to Pin 1 (ground) only, and the Hot (center conductor) side to Pin 2 (+).

MIC OUTPUT XLR connector. Balanced, mic-level output. Connections are Pin 1 ground, Pin 2 high (+), and Pin 3 low (-).

Mute Control

MUTE CONTROL Euroblock terminal connector. Unbalanced muting port for “cough switch” control. A simple contact closure between the + and ground terminals of the MUTE connector will silence the output. Any SPST switch or relay contact will work.

If you would like to use the mute feature as a “push-to-talk” function, use a normally-closed relay or switch contact. When the switch is pushed (or the relay is energized), the contacts will open and un-mute the audio signal.

The open-circuit voltage at the + terminal is about 15 volts DC, limited by a 20,000 Ohm resistor. Take care not to apply any foreign voltage potential to these terminals.

Inputs

LINE INPUT XLR connector or Euroblock connector. 10-kilohm balanced bridging line input intended for signals ranging from -10 dBu to +4 dBu. Connections are Pin 1 ground, Pin 2 high (+), and Pin 3 low (-). For unbalanced connection to the LINE INPUT, we recommend connecting the input cable shield to both Pins 1 and 3, and the center cable conductor to Pin 2.

MIC INPUT XLR connector. Balanced input suitable for low-impedance microphones. 48V phantom powering available. Connections are Pin 1 ground, Pin 2 high (+), and Pin 3 low (-). We do not recommend feeding the MIC INPUT from an unbalanced source.

MIC PAD Pushbutton switch inserts a 15dB pad for strong mic signals.

PHANTOM POWER Pushbutton switch enabling phantom power on MIC INPUT.

527E

Following are some tips and techniques for using the 527E. You should consider any settings given as starting points for developing your own settings.

Metering

The 527E has several LED bargraphs that serve as gain reduction and output meters. The gain-reduction meters indicate the change, from unity gain, for their respective function and the LEDs read (and move) from top to bottom. When operating as a level meter, the LEDs read (and move) from bottom to top. Each meter has its own scale markings, as shown on the front panel.

Gain Setting

There are two places to adjust the gain of the 527E: at the mic input, before any processing, and at the output.

First, the mic input gains. You make best use of the 527E's signal-to-noise ratio by ensuring that your mic-level input signals are adjusted to fit within the headroom of the mic preamp. Doing so ensures optimum dynamic range through the mic preamp and succeeding processors. With the Expander/Compressor, Filter, and EQ sections temporarily set to BYPASS and the OUTPUT GAIN control set to 0 dB (12:00 o'clock), set the MIC GAIN control so that the OUTPUT LEVEL display indicates levels in the -10 to 0 VU range. The CLIP LED should never illuminate on signal peaks. Remember to restore the settings of the various bypass switches.

Finally, the OUTPUT GAIN. After adjusting all of the other processors, set this control so that the 0 VU LED on the OUTPUT LEVEL meter illuminates. The red CLIP LED should never illuminate.

The output CLIP LED also monitors the EQ section. If the CLIP LED illuminates, reduce the OUTPUT GAIN control setting slightly and/or reduce the amount of boost that you are applying in the EQ section. You may need to increase the gain of some device following the 527E to achieve the same overall level.

Downward Expander

Expander operation is easily misunderstood unless it's remembered that what's being expanded is the dynamics, or changes, of signals passing through the circuit. Expanders come in two very different types: linear, and downward.

Linear expanders increase the dynamic range of all signals, no matter what their actual level. The linear expander simply makes all changes greater by some ratio, which is sometimes user adjustable. In the real world, linear expanders aren't too practical because clipping occurs when signals just below maximum output level are expanded.

For instance, an unprocessed signal 3 dB below clipping that increases 2 dB won't distort, because it's still 1 dB below maximum. But if that same signal is passed through an expander operating at a 1:2 ratio, the same 2 dB change at the expander's input becomes a 4 dB change at its output. However, that signal would be 1 dB over maximum, causing distortion. Linear expanders must be used with care, because very few systems have enough headroom to handle the upward dynamic range increase they produce.

The kind of processor most commonly called an expander is really a downward expander, because it only affects signals below threshold. This gives the operator control over the expander's activities, allowing it to be used to expand the usable dynamic range of the system without running out of headroom. The 527E uses a downward expander.

The lower limit restriction of a system is the noise floor, which is usually well below the 527E's lowest expander threshold. It's important to keep in mind that while the signal levels may change greatly, the noise usually doesn't change very much. The action of the expander increases the dynamic range of all signals below threshold. This action increases the apparent loudness of signals, while decreasing the apparent loudness of the noise.

527E

For example, an expander operating at a ratio of 1:2 will cause an input signal that falls 10 dB below threshold to fall 20 dB at its output. The downward action of the expander reduces the noise floor by the same ratio applied to the signal. Since the relationship between the signal and the noise stays the same, the noise is reduced 20 dB by the action of expander, which is responding to a 10 dB drop in the signal with its 1:2 ratio.

Think about using the expander when you are faced with a noisy signal (not necessarily hiss) or when heavily compressing a voice and you want to remove some of the less desirable artifacts (false teeth rattling, lip smacking, tongue noise, etc.) You can also use the expander to help remove microphone leakage from a signal.

Start by setting the threshold so that the expander causes gain reduction (left LED meter) as the signal falls in level. Increasing threshold levels (less negative numbers) cause further reductions in the overall gain as the signal level falls.

Compression

The compressor generally controls peak levels and helps to maintain a high overall average signal level. Used in this manner, the compressor's action is generally inaudible. Compressors can also be used creatively, to make a source sound louder than it really is, or to create a special effect.

For most level control applications, moderate settings yield the best results. We recommend a starting point of: COMP THRESHOLD control setting sufficient to cause about 6 to 8 dB of gain reduction on peaks using a COMP RATIO setting of 4:1.

For a highly compressed sound (you know, the used car salesman during the 3AM movie), use a 10:1 ratio setting and 10 dB or more of gain reduction.

Filtering

The filter section of the 527E features a low cut filter, useful for cleaning up muddiness and eliminating rumble, and a high cut filter, for removal of objectionable high frequency noises, such as sibilance and tape hiss. The low cut filter is tunable and reduces frequencies below the user-selected cutoff frequency by 12 dB per octave. The high cut filter is tunable and reduces frequencies above the user-selected cutoff frequency by 12 dB per octave.

Equalization

The 527E's parametric equalizer has three overlapping bands. Each band can operate as a peaking or dipping equalizer. The boost and cut range for each band is ± 15 dB. The bandwidth may be varied from 0.3 to 4-octaves wide.

Since the bands overlap, it is possible to apply equalization at the same frequency in two places. Doing so could conceivably increase the signal level by 30 dB at one frequency. You may need to reduce the INPUT or OUTPUT GAIN to avoid distortion. Likewise, large amounts of boost in any one band may require reducing the setting of the OUTPUT GAIN control to prevent overload. Let the OUTPUT CLIP LED be your guide.

A parametric equalizer offers perhaps the greatest flexibility of any type of equalizer, however it can be more difficult to arrive at a setting than with other equalizers. A good strategy for setting any equalizer is to set the level control for maximum boost, then vary the Frequency and Bandwidth until you locate the portion of the spectrum that you wish to modify. Then refine the setting of the Level control for that band. Next refine the setting of the Bandwidth control. You may have to go back and forth between Level and Bandwidth to find the magic setting. Toggling the EQ Bypass switch between in and out can help too.

As a rule, it is much easier to hear changes in amplitude (level) than it is to hear bandwidth changes. It is also easier to hear the abundance of something rather than the absence of the same thing. Even if you intend to apply cut (negative level) to a particular frequency, it is still easier to find that frequency by boosting first, tuning second, and resetting the boost/cut last according to

527E

taste or need. Finally, you may find that more natural sounds result when you use wider bandwidths for boosting, narrower bandwidths for cutting. Regardless, there are no hard and fast rules and in the end, whatever works for you is best.

It's generally easier to apply boost to a sound for shaping (and that's how many engineers start). Many times, however, you may want to experiment with removing an offending sound (as opposed to drowning it out with something else). In a complex mix, this may work better because it may require less overall EQ to remove the offending sound; the end result will sound more natural.

Phantom Power

In a nutshell, here are the do's and don'ts of phantom powering:

DO: Verify that your microphone can be phantom powered (if it is a condenser mic).

Ensure that your microphone's output is low impedance, balanced and floating. This is especially important for ribbon mics.

Turn the phantom power off when connecting vintage ribbon microphones.

Mute your monitor speakers or headphones when turning the phantom power on or off. If you don't, there will be a loud, nasty pop.

Mute your monitor speakers or headphones whenever you plug in or unplug a phantom powered microphone. If you don't, there will be a loud, nasty pop.

DON'T: Plug in an A-B powered microphone without a suitable adapter.

Worry about your dynamic or ribbon microphones, as long as they are wired so that the output is balanced and floating.

Use the microphone input for line-level sources, especially those that are transformerless.

Use the microphone input with unbalanced sources. Use a direct box to convert the unbalanced source to balanced. Then, connect the balanced direct box output to the 527E's microphone input.

Worry about your tube condenser mics. They are compatible (although they cannot be phantom powered).

Mute Control

A contact closure between the positive and ground terminals of the 527E's rear-panel MUTE CONTROL will mute the output by at least 60dB. Any SPST switch or relay contact will work.

Note Do not apply any external power source to the mute connector. Do not use the ground terminal for any purpose other than mute switching.

The open-circuit voltage at the positive terminal is 5 V (DC limited by approximately 20k Ohms).

527E

The 527E Voice Processor was designed to make the same kind of specialized processing that's applied to voice-overs and vocal tracks in recording studios available for use in paging, public address and sound reinforcement. Typical applications will include a range of installations from stadiums to churches. For example, use the 527E on stadium announcement mics where extra vocal processing is required to help overcome the inherent acoustic problems that hinder intelligibility in large venues. Churches often have key mics needing extra processing, such as lapel or wireless mics. Adding the 527E to a key mic prior to the automatic mixer in churches yields significant control advantages.

The following discussions illustrate some of the more useful applications for the 527E. As a result of its versatility, combinations of the applications described here will normally be used.

Microphones - Compressing, Limiting, Expanding

The 527E's dynamic range processor is used to control both over-modulation and noise. Noise, in this case, may be electrically induced (hum, buzz, etc.), or acoustically transferred (paper rattling, air conditioning, etc.), since the downward expander attenuates all below-threshold signals without regard to origin. Careful adjustment of the two threshold controls allows the operator to put the 527E to work on any portion of the dynamic range. The expand threshold control governs the 527E's activity in the lower part of the dynamic range, while the comp threshold governs activity in the upper part of the range.

For smooth overall dynamic range processing that will tend to "homogenize" the sound and remove only very low level noises, use a gentle compression ratio with a relatively high comp threshold, and a relatively low expand threshold.

The soft-knee transition characteristic of the interactive processor allows the use of much higher compressor/limiter ratios with much lower thresholds. The expander's rapid rise below its threshold, combined with the compressor's smooth transition through its threshold, makes processing go unnoticed. Use this application to "tighten up" voice signals. The expander eliminates noise and adds "punch."

Use the expander to remove background noise whether or not the compressor is being used. Be sure the expander threshold is set low enough to allow even the lowest level speech sounds to pass. If set correctly, the threshold will attenuate whenever a mic is not in use, eliminating extraneous pickup of stage sounds and reducing feedback. To remove the compressor, set the compression ratio to 1 (essentially out of the circuit).

Likewise, the compressor/limiter may be used without the expander to control only the upper end of the dynamic range. For general purpose overall gain control, use compression. Set the ratio between 2:1 and 3:1, with a comp threshold setting that results in 6dB to 10dB attenuation.

Limiting is used for very definite control of the maximum level. As the name implies, limiting sets the upper limit, but is not intended for general purpose overall gain control. For limiting, set the ratio at 10:1, with the comp threshold control set to provide no more than 3dB to 6dB attenuation.

Bear in mind that limiting is an extreme dynamic control action intended to prevent overload farther down the line. Limiting may be more pleasing to the ear than clipping distortion, but it doesn't generally sound good enough to be used for more than 6dB attenuation.

Increasing Gain Before Feedback

To optimize a PA system's response for minimum feedback, tune out the feedback using the parametric equalizer. To find and eliminate resonances that can become feedback problems, turn the system on, with the microphone(s) and speaker(s) in place as they will normally be used, then follow the sequence below. Gain before feedback should increase about 6dB (perhaps as much as 15dB) with this technique.



-
1. Note the settings of each of the compressor controls.
 2. Temporarily set the compressor ratio to 10:1. Increase system gain very carefully until a feedback frequency becomes slightly audible.
 3. With the bandwidth set at about .3 octave, and the cut/boost control set for about -15dB, tune the frequency control of one section until the feedback is no longer audible.
 4. Increase system gain until feedback becomes slightly audible again.
 - A. If it's the same frequency that was heard first, readjust the same frequency and bandwidth controls until it again subsides.
 - B. If it's a new frequency, repeat Step 2 using another of the EQ sections.
 5. Increase gain again to find the third most prominent feedback frequency. Repeat Step 2 using yet another of the EQ sections.
 6. Reduce system gain to normal operating levels.

The high cut and low cut filters may also be used to eliminate feedback that falls within their ranges. However, using the filters in this manner may result in a larger amount of the frequency spectrum being removed than if you used the parametric EQ (depending on the setting of the parametric EQ's bandwidth controls).

High Level Paging and Public Address Systems - Dynamic Processing

Public address and sound reinforcement situations that require compression/limiting are often plagued by feedback problems. Usually the "make up gain" used with compression causes an overall increase in level which in turn, can cause feedback in the absence of signal, when the compressor releases and brings the gain back up to normal.

The 527E's interactive dynamics processor allows the use of large amounts of comp/limiting without serious side effects. When compression is applied to "normal" signal levels, the compressor returns to unity gain when the signal goes away. This action increases overall system gain. The 527E's expander, on the other hand, decreases gain whenever signals fall below threshold. Careful setting of the two threshold controls tells the 527E how and when to adjust the gain.

Pages and announcements can be made much "tighter" with compression, but in high-sound-level situations, feedback problems may make even gentle, low-ratio compression impossible. The 527E's interactive processor performs exceedingly well in this situation, because the expander decreases gain to compensate for the gain increase that results from compression.

Careful adjustment of the expander threshold control will prevent feedback in the absence of signal, even with substantial compression. Note that in most cases the expander threshold must be set lower than the compressor threshold.

527E

Troubleshooting Chart

<u>SYMPTOM</u>	<u>PROBABLE CAUSE</u>
No output	<p>Check cables and connections.</p> <p>Are inputs driven by outputs, and outputs driving inputs?</p> <p>Verify cables, source and load by patching input and output connections together at the unit.</p> <p>Check for AC power presence. Power LED on?</p> <p>Check output by plugging headphones into output connector (use an adapter).</p> <p>Are the LED displays operating?</p> <p>Did you use the correct output (mic or line-level)?</p> <p>Is the MIX CONTROL set correctly?</p>
Hum or buzz in output	<p>Check input and output connector wiring.</p> <p>Ground loop. Check related system equipment grounding. Are all system components on the same AC ground?</p>
Distortion	<p>Check input signal. Is it too hot, or is it already distorted?</p> <p>Is the OUTPUT display indicating clipping ?</p> <p>Is the input clipping?</p> <p>Check output loading. Should be above 600 ohms.</p> <p>Are the power amplifiers clipping?</p> <p>Is something else clipping?</p>
Noise (hiss)	<p>Check input signal levels and level control settings.</p> <p>The OUTPUT display should indicate signal up to but not including the CLIP LED.</p> <p>Check gain settings on upstream equipment.</p> <p>Is the input signal already noisy?</p> <p>The system gain structure should be such that the 527E operates at or near unity.</p> <p>Is the 527E set for mic-level output, driving a line-level input, with the 527E's gain set fairly high and upstream devices contributing a significant amount of gain?</p>
No LED displays	<p>Is the unit plugged in and turned on?</p> <p>Is the AC outlet OK?</p>
No nothing	<p>If you are using a condenser microphone, is the phantom power switched on?</p> <p>Did you connect to the proper input and output?</p> <p>Is everything downstream really live?</p> <p>Is the DOWNWARD EXPANDER THRESHOLD set too high?</p>

527E

527E Specifications

Inputs

Microphone Input Clip LED	Fires at 1 dB below clipping of mic preamp
Microphone Input Type	Balanced Transformerless, Low Impedance
Phantom Power	+48V nominal
Microphone Preamp Gain	20 to 60 dB (pad out), 5 to 45 dB (pad in)
Microphone Input Maximum Input Level	0 dBu (pad out)
Equivalent Input Noise (EIN)	-126 dBu (60 dB gain, 20 kHz noise bandwidth)
THD+Noise (Preamp only)	0.02% (1 kHz, 50 dB gain, +10 dBu output)
Microphone Preamp CMRR	> 60 dB (40 dB gain, 20 Hz to 20 kHz)
Line Input Type and Impedance	10k Ohms Transformerless, Balanced Bridging
Line Input Maximum Input Level	+20 dBu
Line Input Nominal Input Level	+4 dBu
Line Input CMRR	> 50 dB (0 dBu, 20 Hz to 20 kHz)

Filters

Low Cut Filter Slope	12 dB/octave
Cutoff Frequency Range	6 Hz to 260 Hz @ -3dB
High Cut Filter Slope	12 dB/octave
Cutoff Frequency Range	3 kHz to 65 kHz @ -3dB

Parametric Equalizer

Type	Three-band Parametric Equalizer
Frequency Ranges of Bands	Low: 16 to 500 Hz Mid: 160 to 6300 Hz High: 680 Hz to 22 kHz
Peak/Dip Bandwidth	0.3 to 4 octaves, measured at maximum boost
Maximum Boost/Cut	±15 dB

Metering

Type	Multi-segment LED bar graph
Output Level	-20, -10, 0, Clip (0 VU = +4 dBu), VU calibrated, peak responding
Expander Gain Reduction	3, 6, 12, 20 dB
Compressor Gain Reduction	3, 6, 9, 12 dB

Overall Performance Data

Frequency Response	20 Hz to 20 kHz (+0, -0.5 dB), EQ out compressor out, downward expander out
THD+Noise	<0.08%, 20 Hz to 20 kHz, +4 dBm output
Noise Floor	-89 dBu (all functions enabled) -95 dBu (with EQ function bypassed)

Dynamic Range Processor

Type	Interactive Comp/Limiter-Downward Expander
Comp/Limiter Ratio	1:1 to 10:1
Downward Expansion Ratio (max)	1:1.8

Outputs

Output Section Type	Balanced, Transformerless
Maximum Output Level	+21 dBu Balanced
Output Clip LED	Fires 3 dB below clipping
Output Source Impedance	200 Ohms, Balanced
Minimum Load Impedance	600 Ohms Balanced or Unbalanced
Output Gain	±15 dB

Physical

Size (hwd)	1.72 x 19 x 6 inches, 4.37 x 48.26 x 15.24 centimeters
Weight	5.1 lbs (2.3kg) net

Electrical

Power Requirements	115V nominal, 105 to 125V AC, 50 to 60 Hz, 15 watts maximum 230V nominal, 205 to 253V AC, 50 to 60 Hz, 15 watts maximum
--------------------	--

Note The maximum operating ambient temperature is 25 degrees C. Specifications subject to change without notice.

527E

527E Architects and Engineers Specifications

The voice processor shall be capable of microphone signal preamplification, line input buffering, downward expansion, compression/limiting, filtering, and parametric equalization.

The unit shall have a low-noise, low distortion microphone preamplifier with variable gain (20 dB to 60 dB) and switchable (on/off) +48V phantom power. A 15 dB pad shall be provided to accommodate high output microphone signals. A balanced-bridging line input suitable for +4 dBu input signals shall also be provided along with a mix control to select either the microphone or line inputs, or a combination of both inputs.

The dynamics processing section shall contain an interactive compressor/limiter and downward expander. There shall be front panel controls for compression ratio (1:1 to 10:1), compressor threshold (-50 dBm to +20 dBm), expander threshold (-30 dBm to 0 dBm), and a bypass switch.

There shall be a 12 dB/Oct high cut filter with a user-adjustable cutoff frequency range 3 kHz to 65 kHz, and a 12 dB/Oct low cut filter with a cutoff frequency range from 6 Hz to 260 Hz.

There shall be a three-band parametric equalizer. Each band shall have ± 15 dB maximum boost/cut, and continuously variable bandwidth (.3 octaves to 4 octaves). The equalizer bands shall have substantially overlapping frequency ranges, with a combined range of 16 Hz to 22 kHz. There shall be a front panel bypass switch.

The voice processor shall be equipped with the following LED displays: A four-segment LED display that monitors the overall output level, a four-segment LED display that monitors the compressor/limiter, and a four-segment LED display that monitors the downward expander. All displays shall be independent. There shall also be a single LED clip indicator to indicate clipping within the mic preamplifiers.

The microphone input shall be an active balanced bridging design terminated with 3-pin XLR-female connector (AES/IEC standard wiring). The microphone preamp shall be capable of an equivalent input noise specification of at least -126 dBu (60 dB gain, 20 kHz noise bandwidth). The line input shall be a balanced, transformerless design using a 3-pin XLR-female connector (AES/IEC standard wiring) and a Euroblock terminal connector. All input circuitry shall incorporate RFI filters of the LC or RC low-pass type.

The line output shall be an active balanced design terminated with a 3-pin XLR-male connector (AES/IEC standard wiring) and a Euroblock terminal connector. The mic output shall terminate with a 3-pin XLR-male connector (AES/IEC standard wiring).

The voice processor shall be capable of operating by means of its own built-in power supply connected to 115V AC nominal (105 to 130V), 50 to 60 Hz or 230V AC nominal (207 to 253V), 50 to 60Hz.

The unit shall be a Symetrix Incorporated model 527E Voice Processor.

527E

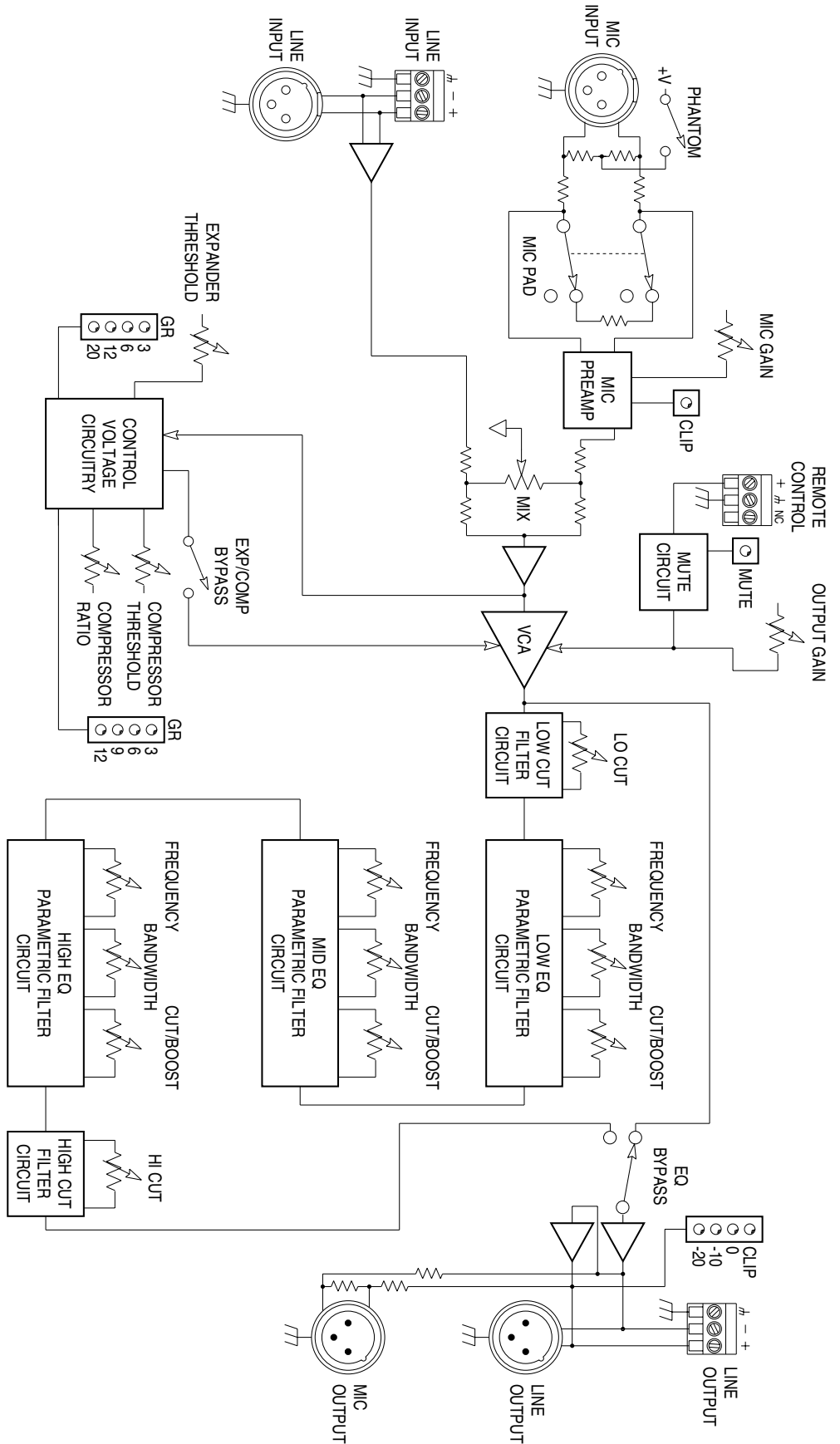

52E

527E Limited Warranty

Symetrix, Inc. expressly warrants that the product will be free from defects in material and workmanship for one (1) year. Symetrix's obligations under this warranty will be limited to repairing or replacing, at Symetrix's option, the part or parts of the product which prove defective in material or workmanship within one (1) year from date of purchase, provided that the Buyer gives Symetrix prompt notice of any defect or failure and satisfactory proof thereof. Products may be returned by Buyer only after a Return Authorization number (RA) has been obtained from Symetrix. Buyer will prepay all freight charges to return the product to the Symetrix factory. Symetrix reserves the right to inspect any products which may be the subject of any warranty claim before repair or replacement is carried out. Symetrix may, at its option, require proof of the original date of purchase (dated copy of original retail dealer's invoice). Final determination of warranty coverage lies solely with Symetrix. Products repaired under warranty will be returned freight prepaid by Symetrix via United Parcel Service (surface), to any location within the Continental United States. At Buyer's request the shipment may be returned via airfreight at Buyer's expense. Outside the Continental United States, products will be returned freight collect.

The foregoing warranties are in lieu of all other warranties, whether oral, written, express, implied or statutory. Symetrix, Inc. expressly disclaims any IMPLIED warranties, including fitness for a particular purpose or merchantability. Symetrix's warranty obligation and buyer's remedies hereunder are SOLELY and exclusively as stated herein.

This Symetrix product is designed and manufactured for use in professional and studio audio systems and is not intended for other usage. With respect to products purchased by consumers for personal, family, or household use, Symetrix **expressly disclaims all implied warranties, including but not limited to warranties of merchantability and fitness for a particular purpose.**

This limited warranty, with all terms, conditions and disclaimers set forth herein, shall extend to the original purchaser and anyone who purchases the product within the specified warranty period.

Warranty Registration must be completed and mailed to Symetrix within thirty (30) days of the date of purchase.

Symetrix does not authorize any third party, including any dealer or sales representative, to assume any liability or make any additional warranties or representation regarding this product information on behalf of Symetrix.

This limited warranty gives the buyer certain rights. You may have additional rights provided by applicable law.

Limitation of Liability

The total liability of Symetrix on any claim, whether in contract, tort (including negligence) or otherwise arising out of, connected with, or resulting from the manufacture, sale, delivery, resale, repair, replacement or use of any product will not exceed the price allocable to the product or any part thereof which gives rise to the claim. In no event will Symetrix be liable for any incidental or consequential damages including but not limited to damage for loss of revenue, cost of capital, claims of customers for service interruptions or failure to supply, and costs and expenses incurred in connection with labor, overhead, transportation, installation or removal of products or substitute facilities or supply houses.

527E

If you have determined that your 527E requires repair services and you live *outside* of the United States please contact your local Symetrix dealer or distributor for instructions on how to obtain service. If you reside in the U.S. then proceed as follows:

At the Symetrix factory, Symetrix will perform in-warranty or out-of-warranty service on any product it has manufactured for a period of five years from date of manufacture.

Before sending anything to Symetrix, contact our Customer Service Department for a return authorization (RA) number. The telephone number is (425) 787-3222, Monday through Friday, 8AM (800 hours) through 4:30 PM (1630 hours), Pacific Time.

In-warranty Repairs

To get your 527E repaired under the terms of the warranty:

1. Call us for an RA number.
2. Pack the unit in its original packaging materials.
3. Include your name, address, daytime telephone number, and a brief statement of the problem.
4. Write the RA number on the outside of the box.
5. Ship the unit to Symetrix, freight prepaid.

We do *not* accept freight collect shipments.

Just do these five things, and repairs made in-warranty will cost you only one-way freight charges. We'll prepay the return (surface) freight.

If you choose to send us your product in some sort of flimsy packaging, we'll have to charge you for proper shipping materials. If you don't have the factory packaging materials, then do yourself a favor by using an oversize carton, wrap the unit in a plastic bag, and surround it with bubble-wrap. Pack the box full of Styrofoam peanuts. Be sure there is enough clearance in the carton to protect the rack ears (you wouldn't believe how many units are returned with bent ears). We won't return the unit in anything but Symetrix packaging for which we will have to charge you. Of course, if the problem turns out to be operator inflicted, you'll have to pay for both parts and labor. In any event, if there are charges for the repair costs, you will pay for the return freight. All charges will be COD unless you have made other arrangements (prepaid, Visa or Mastercard).

Out-of-warranty Repairs

If the warranty period has passed, you'll be billed for all necessary parts, labor, packaging materials, and freight charges. Please remember, you must call for an RA number before sending the unit to Symetrix.

527E

Declaration of Conformity

We, **Symetrix Incorporated**,
14926 35th Ave. West, Lynnwood, Washington, USA,
declare under our sole responsibility that the product:

527E Voice Processor

to which this declaration relates,
is in conformity with the following standards:

EN 60065
Safety requirements for mains operated electronic and related apparatus for household and similar general use.

EN 55103-1
Electromagnetic compatibility - Generic emission standard
Part 1: Residential, commercial, and light industry.

EN 55103-2
Electromagnetic compatibility - Generic immunity standard
Part 1: Residential, commercial, and light industry.

The technical construction file is maintained at:

Symetrix, Inc.
14926 35th Ave. West
Lynnwood, WA, 98037-2303
USA

The authorized representative located within the European Community is:

World Marketing Associates
P.O. Box 100
St. Austell, Cornwall, PL26 6YU, U.K.

Date of issue: July 20, 1999
Place of issue: Lynnwood, Washington, USA
Authorized signature:



Dane Butcher, President, **Symetrix Incorporated**.

527E

527E

 **Symetrix**



Symetrix, Inc.

14926 35th Ave. West
Lynnwood, WA, 98037-2303

USA

Tel: (425) 787-3222

Fax: (425) 787-3211

Website: <http://www.symetrixaudio.com>

Email: symetrix@symetrixaudio.com