

R93 DYNAMIC MICROPHONE CARTRIDGE

The Model R93 Dynamic Microphone Cartridge is a direct replacement for Shure SM1, SM2, SM10, SM12, SM14 and other head-worn microphones.

R93 MICROPHONE CARTRIDGE REPLACEMENT

1. Unscrew (turn counterclockwise) the end cap from the microphone housing. See Figure 1. This operation can be performed with the fingers; the end cap is only installed finger tight.

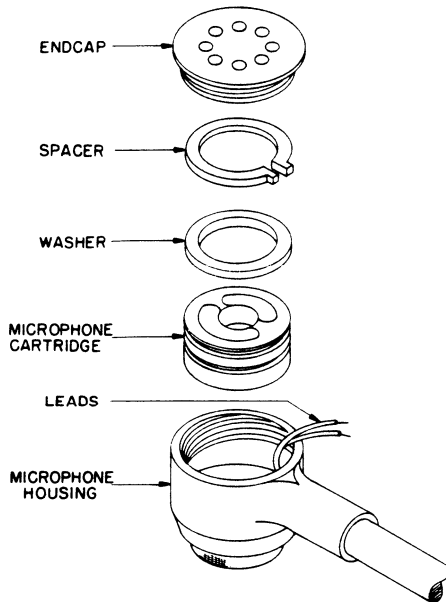
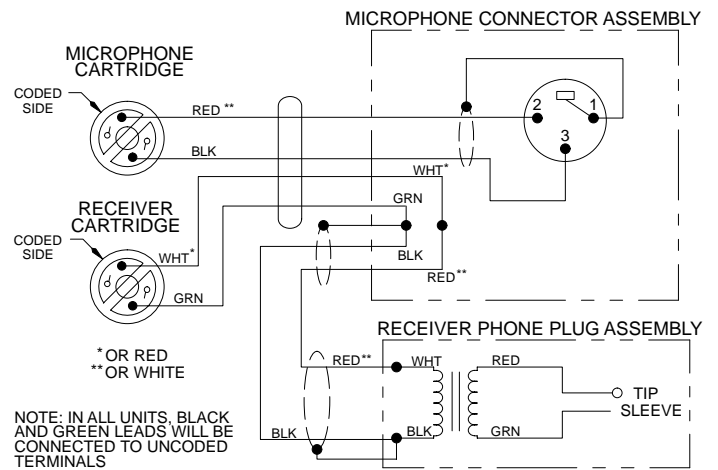

FIGURE 1

2. Unsolder the RED and BLACK leads from the cartridge terminals.
3. Pry up and remove the white spacer and black washer from the housing.
4. Hold the housing open side down and tap to remove the cartridge.
5. Insert the replacement cartridge into the housing. Place the black washer on the cartridge and the

white spacer on the black washer. The two projections on the spacer should be located in the sealant and on either side of the leads that emerge from the boom.

6. Solder the RED and BLACK leads to the copper terminals (RED lead to the coded terminal.) See Figure 2.



(MICROPHONE ONLY IN SM10)
INTERNAL CONNECTIONS

FIGURE 2

CAUTION: Take care not to solder to the existing soldered areas nor to disturb the existing solder. Solder quickly and efficiently using minimum heat.

7. Reinstall the end cap finger tight.

For additional service or parts information, please contact Shure's Service department.

