



Redbox User Handbook No 2

Matching Converters, Distribution Amplifiers & Headphone Amplifiers

- | | |
|-----------------|--|
| RB-UL1 | Single stereo unbalanced to balanced converter |
| RB-UL2 | Dual stereo unbalanced to balanced converter |
| RB-UL4 | Quad stereo unbalanced to balanced converter |
| RB-LU4 | Quad stereo balanced to unbalanced converter |
| RB-BL2 | Single stereo bi-directional matching converter |
| RB-BL4 | Dual stereo bi-directional matching converter |
| RB-PA2 | Dual stereo RIAA phono amplifier |
| RB-LI2 | Stereo line isolation unit |
| RB-PLI6 | 6 way mono passive line isolation unit |
| RB-DA6 | 6 way stereo distribution amplifier |
| RB-DA6G | 6 way stereo distribution amplifier with output gain control |
| RB-DA4x5 | 4 input, 4 x 5 output distribution amplifier/mixer |
| RB-DDA6A | 6 way stereo AES/EBU digital distribution amplifier |
| RB-DDA6S | 6 way stereo S/PDIF digital distribution amplifier |
| RB-DDA6W | 6 way word clock digital distribution amplifier |
| RB-HD1 | Stereo headphone amplifier |
| RB-HD2 | Dual stereo headphone amplifier |
| RB-HD6 | 6 way stereo headphone distribution amplifier |
| RB-DHD6 | Digital 6 way stereo headphone distribution amplifier |

SONIFEX





Revision 2.02 June, 2007

©Sonifex Ltd, 2000-7

All Rights Reserved

**Sonifex Ltd, 61, Station Road, Irthlingborough,
Northants, NN9 5QE, England.**

Tel : +44 (0)1933 650 700

Fax : +44 (0)1933 650 726

Email : sales@sonifex.co.uk or technical.support@sonifex.co.uk

Web : <http://www.sonifex.co.uk>

Information in this document is subject to change without notice and does not represent a commitment on the part of Sonifex Ltd. Sonifex Ltd shall not be liable for any loss or damage whatsoever arising from the use of information or any error contained in this manual.

No part of this manual may be reproduced or transmitted in any form or by any means, electronic or mechanical, including photocopying, recording, or information storage and retrieval systems, for any purpose other than the purchaser's personal use, without the express written permission of Sonifex Ltd.

Unless otherwise noted, all names of companies, products and persons contained herein are part of a completely fictitious adaptation and are designed solely to document the use of Sonifex products.



CONTENTS



CONTENTS

Warranty		i
Warranty and Liability - important the purchaser is advised to read this clause		i
Unpacking the Redbox		ii
Returning the Warranty Card		iii
Safety Information		iii
Safety of Mains Operated Equipment		iii
Voltage Setting Checks		iii
Fuse Rating		iii
Power Cable and Connection		iv
Ordering the Correct Mains Lead		iv
Installation Information		iv
Atmosphere		iv
Electromagnetic Radiation		iv
Fitting Redboxes		iv
WEEE & RoHS Directives - Sonifex Statement		vi
MATCHING CONVERTERS		
1 RB-UL1 Single, RB-UL2 Dual & RB-UL4 Quad Stereo Unbalanced To Balanced Converters		1
Introduction		1
System Block Diagram		1
Rear Panel Connections and Operation		2
RCA Phono Inputs (Left and Right)		3
Outputs (Left and Right)		3
Output Level Adjustment		3
Technical Specifications		4
2 RB-LU4 Quad Stereo Balanced To Unbalanced Converter		5
Introduction		5
System Block Diagram		6
Rear Panel Connections and Operation		7
Inputs 1-4 (Left and Right)		7
RCA Phono Outputs 1-4 (Left and Right)		7
Output Level Adjustment		7
Technical Specifications		8
3 RB-BL2 Single & RB-BL4 Dual Bi-Directional Matching Converter		9
Introduction		9
System Block Diagram		10
Rear Panel Connections and Operation		10
Balanced to Unbalanced Connections		11
Inputs 1 (& 3) (Left & Right)		11
Output Level Adjustment		11
Unbalanced to Balanced Connections		11
RCA Phono Inputs 2 (& 4) (Left & Right)		11
Technical Specifications		12
4 RB-PA2 Dual Stereo RIAA Phono Amplifier		13
Introduction		13
System Block Diagram		13
Rear Panel Connections and Operation		14

CONTENTS



CONTENTS

RCA Phono Inputs (Left and Right)	14
Outputs (Left and Right)	14
Output Level Adjustment	14
Pick-up Grounding Post	14
Technical Specifications	15

5 RB-LI2 Stereo Line Isolation Unit 16

Introduction	16
System Block Diagram	16
Rear Panel Connections and Operation	17
Inputs	17
Isolated Outputs	17
Loop Outputs	17
Output Level Adjustment	17
Internal Jumpers	18
Technical Specifications	18

6 RB-PLI6 6 Way Mono Passive Line Isolation Unit 19

Introduction	19
System Block Diagram	19
Rear Panel Connections and Operation	20
Inputs	20
Outputs	20
Ground-link Internal Jumpers	20
Technical Specifications	21

AUDIO DISTRIBUTION AMPLIFIERS

7 RB-DA6 & RB-DA6G 6 Way Stereo Distribution Amplifier 22

Introduction	22
System Block Diagram	23
Connections and Operation	24
Stereo Outputs 1-6 (Mono Outputs 1-12)	24
Input Gain Control (RB-DA6)	24
Output Gain Control (RB-DA6G)	24
Stereo/Mono Operation	25
Technical Specifications	25

8 RB-DA4x5 4 Input 4 x 5 Output Distribution Amplifier/Mixer 26

Introduction	26
System Block Diagram	27
Rear Panel Connections and Operation	27
Audio Inputs 1-4	27
D-Type Audio Output Groups 1-4	28
Monitor LEDs	28
Input Level Adjustment	28
Output Level Adjustment	28
Routing Selection	28
Alignment Test Tone	29
Technical Specifications	29

9 RB-DDA6A 6 Way Stereo AES/EBU Digital Distribution Amplifier and RB-DDA6S 6 Way Stereo S/PDIF Digital Distribution Amplifier 30

Introduction	30
System Block Diagrams	31-32



CONTENTS



CONTENTS

Rear Panel Connections and Operations	33
AES/EBU Input	33
AES/EBU Outputs	33
S/PDIF Input	33
S/PDIF Outputs	33
Technical Specifications	34

10 RB-DDA6W 6 Way Word Clock Distribution Amplifier 35

Introduction	35
System Block Diagram	36
Rear Panel Connections and Operations	37
Word Clock Input	37
Word Clock Outputs	37
Technical Specifications	37

HEADPHONE DISTRIBUTION AMPLIFIERS

11 RB-HD1 Stereo Headphone Amplifier & RB-HD2 Dual Headphone Amplifier 38

Introduction	38
System Block Diagrams	39
Front Panel Connections and Controls	40
Stereo Outputs 1-2 (Mono Outputs 1-2)	40
Volume Level Control	40
Stereo Outputs 1-2 (Mono Outputs 1-2)	40
Channel Volume Controls	40
Rear Panel Connections and Operation	41
Main Stereo Inputs (Left and Right)	41
Stereo Input Gain Adjustment (RB-HD1)	41
Stereo/Mono Operation	42
Mono Mix Input (RB-HD1)	42
Mono Mix Input Gain Adjustment (RB-HD1)	42
Local/Remote Control Operation (RB-HD1)	42
Remote Connector (RB-HD1)	42
Technical Specifications	43

12 RB-HD6 6 Way Headphone Distribution Amplifier 44

Introduction	44
System Block Diagram	45
Rear Panel Connections and Operation	46
Stereo Input (Left and Right)	46
Stereo/Mono Operation	46
Channel Insertion Inputs/Parallel Outputs	46
Removing the Equipment Covers	46
Configuring Insert Inputs/Parallel Outputs	47
Front Panel Connections and Controls	47
Stereo Outputs 1-6 (Mono Outputs 1-6)	47
Master Level Control	48
Channel Volume Controls	48
Technical Specifications	48

13 RB-DHD6 Digital 6 Way Headphone Distribution Amplifier 49

Introduction	49
System Block Diagram	49

CONTENTS



CONTENTS

Front Panel Indicators & Controls	49
Introduction	49
Sync & Power Indicator	50
Headphone Outputs	50
Volume Control	50
Rear Panel Connections and Operation	50
AES/EBU Input	50
S/PDIF Input	50
Status Select Switches	50
Digital Input Select Button	51
Technical Specifications	51

14 Connectors & Cabling **52**

XLR 3 Pin Connectors	52
RCA Phono Connectors	52
D-Type Connectors	53

15 Glossary **54**



FIGURES

Figures

Fig A: Packing List.	ii
Fig B: Mains Cable Wire Colours	iv
Fig C: Mains Lead Table.	iv
Fig D: RB-RK1 Small Redbox Front Rack-mount Kit .	v
Fig E: RB-RK2 Small Redbox Rear Rack-mount Kit.	v
Fig F: RB-RK3 Large Redbox Rear Rack-mount Kit.	v
Fig 1-1: RB-UL1 & RB-UL2 Front Panel.	1
Fig 1-2: RB-UL4 Front Panel.	1
Fig 1-3: Block Diagram For a Single Channel (x2 for RB-UL2, x4 for RB-UL4).	1
Fig 1-4: RB-UL1 Rear Panel.	2
Fig 1-5: RB-UL2 Rear Panel.	2
Fig 1-6: RB-UL4 Rear Panel.	2
Fig 2-1: RB-LU4 Front Panel.	5
Fig 2-2: RB-LU4 Block Diagram.	6
Fig 2-3: RB-LU4 Rear Panel.	7
Fig 3-1: RB-BL2 Front Panel.	9
Fig 3-2: RB-BL4 Front Panel.	9
Fig 3-3: RB-BL2/BL4 Block Diagram Single Stereo Channel.	10
Fig 3-4: RB-BL2 Rear Panel.	10
Fig 3-5: RB-BL4 Rear Panel.	11
Fig 4-1: RB-PA2 Front Panel.	13
Fig 4-2: RB-PA2 Block Diagram For a Single Stereo Channel.	13
Fig 4-3: RB-PA2 Rear Panel.	14
Fig 5-1: RB-LI2 Front Panel.	16
Fig 5-2: RB-LI2 System Block Diagram.	16
Fig 5-3: RB-LI2 Rear Panel.	17
Fig 6-1: RB-PLI6 Front Panel.	19
Fig 6-2: RB-PLI6 System Block Diagram.	19
Fig 6-3: RB-PLI6 Rear Panel.	20
Fig 6-4: RB-PLI6 Ground-link Jumper Settings.	20
Fig 7-1: RB-DA6 Front Panel.	22
Fig 7-2: RB-DA6G Front Panel.	22
Fig 7-3: RB-DA6 Block Diagram.	23
Fig 7-4: RB-DA6G Block Diagram.	23
Fig 7-5: RB-DA6 & RB-DA6G Rear Panel.	24
Fig 7-6: RB-DA6 Front Panel.	24
Fig 7-7: RB-DA6G Front Panel.	25
Fig 8-1: RB-DA4x5 Front Panel.	26
Fig 8-2: RB-DA4x5 Block Diagram.	27
Fig 8-3: RB-DA4x5 Rear Panel.	27
Fig 8-4: RB-DA4x5 Audio Output Group 15-Way D-Type Plug.	28



FIGURES

FIGURES



FIGURES

Fig 8-5: RB-DA4x5 Pinout for Audio Output Group Connector.	28
Fig 8-6: RB-DA4x5 Routing Selection Switch.	28
Fig 8-7: RB-DA4x5 Routing Selection Switch Functions.	29
Fig 9-1: RB-DDA6A/S Front Panel.	30
Fig 9-2: RB-DDA6A System Block Diagram.	31
Fig 9-3: RB-DDA6S System Block Diagram.	32
Fig 9-4: RB-DDA6A Rear Panel.	33
Fig 9-5: RB-DDA6S Rear Panel.	33
Fig 10-1: RB-DDA6W Front Panel.	35
Fig 10-2: RB-DDA6W System Block Diagram.	36
Fig 10-3: RB-DDA6W Rear Panel.	37
Fig 11-1: RB-HD1 Front Panel.	38
Fig 11-2: RB-HD2 Front Panel.	38
Fig 11-3: RB-HD1 Block Diagram.	39
Fig 11-4: RB-HD2 Block Diagram.	39
Fig 11-5: RB-HD1 Front Panel Controls.	40
Fig 11-6: RB-HD2 Front Panel Controls.	40
Fig 11-7: RB-HD1 Rear Panel.	41
Fig 11-8: RB-HD2 Rear Panel.	41
Fig 11-9: RB-HD1 Remote Connector	42
Fig 12-1: RB-HD6 Front Panel.	44
Fig 12-2: RB-HD6 Block Diagram.	45
Fig 12-3: RB-HD6 Rear Panel.	46
Fig 12-4: RB-HD6 Jumper Assignments.	47
Fig 12-5: RB-HD6 Jumper Positions.	47
Fig 12-6: RB-HD6 Front Panel Controls.	47
Fig 12-7: RB-HD6 Master Level Control.	48
Fig 13-1: RB-DHD6 Front Panel.	49
Fig 13-2: RB-DHD6 System Block Diagram.	49
Fig 13-3: RB-DHD6 Front Panel Controls.	49
Fig 13-4: RB-DHD6 Rear Panel.	50
Fig 13-5: RB-DHD6 Status Select Switches.	50
Fig 14-1: XLR Connectors.	52
Fig 14-2: RCA Phono Connector.	52
Fig 14-3: ¼" Jack Connector.	52
Fig 14-4: 25 Way D-Type Connectors.	53
Fig 14-5: 15 Way D-Type Connectors.	53
Fig 14-6: 9 Way D-Type Connectors.	53



Warranty

Warranty and Liability - important the purchaser is advised to read this clause

- (a) The Company agrees to repair or (at its discretion) replace Goods which are found to be defective (fair wear and tear excepted) and which are returned to the Company within 12 months of the date of despatch provided that each of the following are satisfied:
- (i) Notification of any defect is given to the Company immediately upon its becoming apparent to the Purchaser;
 - (ii) The Goods have only been operated under normal operating conditions and have only been subject to normal use (and in particular the Goods must have been correctly connected and must not have been subject to high voltage or to ionising radiation and must not have been used contrary to the Company's technical recommendations);
 - (iii) The Goods are returned to the Company's premises at the Purchaser's expense;
 - (iv) Any Goods or parts of Goods replaced shall become the property of the Company;
 - (v) No work whatsoever (other than normal and proper maintenance) has been carried out to the Goods or any part of the Goods without the Company's prior written consent;
 - (vi) The defect has not arisen from a design made, furnished or specified by the Purchaser;
 - (vii) The Goods have been assembled or incorporated into other goods only in accordance with any instructions issued by the Company;
 - (viii) The defect has not arisen from a design modified by the Purchaser;
 - (ix) The defect has not arisen from an item manufactured by a person other than the Company. In respect of any item manufactured by a person other than the Company, the Purchaser shall only be entitled to the benefit of any warranty or guarantee provided by such manufacturer to the Company.
- (b) In respect of computer software supplied by the Company the Company does not warrant that the use of the software will be uninterrupted or error free.
- (c) The Company accepts liability:
- (i) For death or personal injury to the extent that it results from the negligence of the Company, its employees (whilst in the course of their employment) or its agents (in the course of the agency);



WARRANTY

WARRANTY



WARRANTY

- (ii) For any breach by the Company of any statutory undertaking as to title, quiet possession and freedom from encumbrance.
- (d) Subject to conditions (a) and (c) from the time of despatch of the Goods from the Company's premises the Purchaser shall be responsible for any defect in the Goods or loss, damage, nuisance or interference whatsoever consequential economic or otherwise or wastage of material resulting from or caused by or to the Goods. In particular the Company shall not be liable for any loss of profits or other economic losses. The Company accordingly excludes all liability for the same.
- (e) At the request and expense of the Purchaser the Company will test the Goods to ascertain performance levels and provide a report of the results of that test. The report will be accurate at the time of the test, to the best of the belief and Knowledge of the Company, and the Company accepts no liability in respect of its accuracy beyond that set out in Condition (a).
- (f) Subject to Condition (e) no representation, condition, warranty or other term, express or implied (by statute or otherwise) is given by the Company that the Goods are of any particular quality or standard or will enable the Purchaser to attain any particular performance or result, or will be suitable for any particular purpose or use under specific conditions or will provide any particular capacity, notwithstanding that the requirement for such performance, result or capacity or that such particular purpose or conditions may have been known (or ought to have been known) to the Company, its employees or agents.
- (g)
 - (i) To the extent that the Company is held legally liable to the Purchaser for any single breach of contract, tort, representation or other act or default, the Company's liability for the same shall not exceed the Price of the Goods.
 - (ii) The restriction of liability in Condition (g)(i) shall not apply to any liability accepted by the Seller in Condition (c).
- (h) Where the Goods are sold under a consumer transaction (as defined by the Consumer Transactions (Restrictions on Statements) Order 1976) the statutory rights of the Purchaser are not affected by these Conditions of Sale.

Unpacking the Redbox

The Redbox is shipped with the following equipment. Please check your packaging to ensure that you have all of the items below. If anything is missing, please contact the supplier of your equipment immediately.

Item	Quantity
Redbox audio interface	1
IEC Mains lead fitted with moulded mains plug	1
Handbook and warranty card	1

Fig A: Packing List.



Each Redbox is shipped in protective packaging and should be inspected for damage before use. Where an item is found to have transit damage, notify the carrier immediately with all the relevant details of the shipment. Packing materials should be kept for inspection and also for if the product needs to be returned.

Returning the Warranty Card

In order to register the date of purchase so that we can keep you informed of any design improvements or modifications, it is important to complete the warranty registration document that is enclosed and return it to Sonifex Ltd in the UK, or register online at www.sonifex.co.uk/register

For your own records you should write down the serial number (which can be found on the rear of the Redbox.

Serial Number
---------------	-------



SAFETY & INSTALLATION INFORMATION

Safety Information

Safety of Mains Operated Equipment



This equipment has been designed to meet the safety regulations currently advised in the country of purchase and it conforms to the safety regulations specified by use of the CE Mark.

Warning : There are no user serviceable parts inside the equipment. If you should ever need to look inside the unit, always disconnect the mains supply before removing the equipment covers.

Voltage Setting Checks

Ensure that the machine operating voltage is correct for your mains power supply by checking the rear panel of your Redbox. The available voltage settings are 115V, or 230V. Please note that all Redboxes are either switchable between 115V and 230V, or have a universal power supply.

Fuse Rating

The Redboxes are supplied with a single fuse in the live conducting path of the power infeed at the power supply. For reasons of safety it is important that the correct rating and type of fuse is used. Incorrectly rated fuses could present a possible fire hazard, under equipment fault conditions. See the Technical Specifications of each product for the fuse rating. The active fuse is fitted on the outside rear panel of the unit.

SAFETY & INSTALLATION INFORMATION



Power Cable and Connection

An IEC power connector is supplied with the Redbox, which has a moulded plug, attached – this is a legal requirement. If no moulded plug has been supplied with your Redbox, please contact your supplier, because an IEC connector is always supplied from the Sonifex factory. If for any reason, you need to use the Redbox with a different power cable, you should use the following wiring guidelines:

Wire Colour	Connection
Green, or green and yellow	Earth (E)
Blue, or Black	Neutral (N)
Brown, or Red	Live (L)

Fig B: Mains Cable Wire Colours

Ordering the Correct Mains Lead

When ordering a Redbox from Sonifex, it is helpful if you can specify your required operating voltage and mains lead. After the product code add:





UK, for 230V, UK 3 pin to IEC lead	
EC, for 230V, European Schuko 2 pin to IEC lead	
US, for 115V, 3 pin to IEC lead	
AU for 230V, Australasian 3 pin to IEC lead	

Fig C: Mains Lead Table.

E.g. order RB-BL2 UK for a UK IEC lead to be supplied.

Installation Information

Atmosphere

The units should be installed in an area that is not subject to excessive temperature variation (<0°C, >50°C), moisture, dust or vibration.

Electromagnetic Radiation

The cover is connected to earth by means of the fixing screws. It is essential to maintain this earth ground connection to ensure a safe operating environment and provide electromagnetic shielding.

Fitting Redboxes

Redboxes can be fixed to the underside of a mixing desk, or other surfaces using 4.2mm holes in the sides and fixed with 2 x M4 screws or 2 x No. 6 countersink wood screws.

They can also be rack-mounted, with either the front, or rear of the Redbox positioned at the front of the rack:

Front Mounting Redboxes: For rack mounting smaller (28cm) units the optional **RB-RK1** (Red) or **RB-RK1B** (Black) kit can be used (which include 4 off M6 panel fixing screws).



Fig D: RB-RK1 Small Redbox Front Rack-mount Kit.

Wherever you see this symbol an RB-RK1 front panel rack kit can be used :



Rear Mounting Redboxes: For rear panel mounting you can use either the RB-RK2, or RB-RK3, depending on the size of your Redbox.

RB-RK2 1U rear panel rack kit for small Redbox range, e.g., RB-BL2



Fig E: RB-RK2 Small Redbox Rear Rack-mount Kit.

e.g. for fitting an RB-BL2:



Wherever you see this symbol an RB-RK2 small Redbox rear panel 19" rack kit can be used :



RB-RK3 1U rear panel rack kit for large Redbox range, e.g., RB-DA6



Fig F: RB-RK3 Large Redbox Rear Rack-mount Kit.

e.g. for fitting an RB-DA6:



Wherever you see this symbol an RB-RK3 large Redbox rear panel 19" rack kit can be used :



Note: When fitting the rear-mounting rack-kits, a notch has been left on the inside of the right-hand rack-piece for the mains cable to pass through. Make sure that the mains cable has been put through the notch before attaching the right hand rack-piece.



SAFETY & INSTALLATION INFORMATION

WEEE & RoHS Directives - Sonifex Statement



The Waste Electrical and Electronic Equipment (WEEE) Directive was agreed on 13 February 2003, along with the related Directive 2002/95/EC on Restrictions of the use of certain Hazardous Substances in electrical and electronic equipment (RoHS).

The **Waste Electrical and Electronic Equipment Directive (WEEE)** aims to minimise the impacts of electrical and electronic equipment on the environment during their life times and when they become waste. It applies to a huge spectrum of products. It encourages and sets criteria for the collection, treatment, recycling and recovery of waste electrical and electronic equipment. All products manufactured by Sonifex Ltd have the WEEE directive label placed on the case. It gives a contact for individuals who are unsure about the correct procedure when the product has reached its “end of use”.

Sonifex Ltd will be happy to give you information about local organisations that can reprocess the products, or alternatively all products that have reached “end of use” can be returned to Sonifex and will be reprocessed correctly free of charge.

Sonifex Ltd has phased out the use of certain hazardous substances identified in the European Union's **Restriction of Hazardous Substances (RoHS)** directive. The RoHS directive limits the use of certain hazardous substances currently used in EEE manufacture, including lead, mercury, cadmium, hexavalent chromium, and halide-containing compounds PBB (polybrominated biphenyl) and PBDE (polybrominated diphenyl ether). Elimination of these substances will result in more environmentally friendly recycling of electronic equipment. For the products which Sonifex manufacture, the main area where products were affected was in the use of lead for manufacturing and assembling electronics circuit boards.

Sonifex Ltd practices lead-free (LF) manufacturing processes. LF solder is used on the surface-mount PCB manufacturing processes and for hand soldering. The printed circuit boards (PCBs) used are either gold plated, or immersion tin plated, both of which use no lead. Historically the PCBs were hot air solder levelled (HASL) PCBs which used tin/lead based solder.

The manufacturing processes include the assembly of purchased components from various sources. Product is offered as RoHS compliant, or LF, only after sufficient evidence is received from the component manufacturers that their components are RoHS compliant. Sonifex Ltd relies solely on the distributor, or manufacturer, of the components for identification of RoHS compliance. Thus whilst every effort is made to ensure compliance, Sonifex Ltd makes no warranty, or certification, or declaration of compliance concerning said components.

Sonifex Ltd defines “Lead Free” as pertaining to any product, which has been manufactured by Sonifex Ltd using components which have been declared by the manufacturers as “Lead Free”. All statements by Sonifex Ltd of RoHS compliance are based on component manufacturer documentation.

1 RB-UL1 Single, RB-UL2 Dual & RB-UL4 Quad Stereo Unbalanced To Balanced Converters

Introduction



Fig 1-1: RB-UL1 & RB-UL2 Front Panel.



Fig 1-2: RB-UL4 Front Panel.

The RB-UL1 single, RB-UL2 dual & RB-UL4 quad stereo units are used for interfacing domestic, or semi-pro unbalanced equipment to professional balanced line levels.

All connections are on the rear panel. The RCA unbalanced inputs have an impedance of 10kΩ bridging and are routed to the balanced XLR-3 outputs with an output impedance of <math><50\Omega</math>.

The RB-UL1 has two inputs & outputs, the RB-UL2 has four inputs & outputs and the RB-UL4 has eight inputs & outputs.

The output gain can be individually adjusted for left and right channels by using pre-set potentiometers accessible through the rear panel. A LED power indicator on the front panel displays the power supply connection.

System Block Diagram

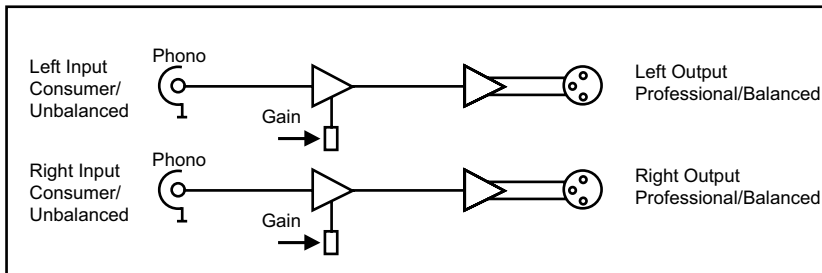

Fig 1-3: Block Diagram For a Single Channel (x2 for RB-UL2, x4 for RB-UL4).



MATCHING CONVERTERS - RB-UL1, RB-UL2, RB-UL4



Rear Panel Connections and Operation

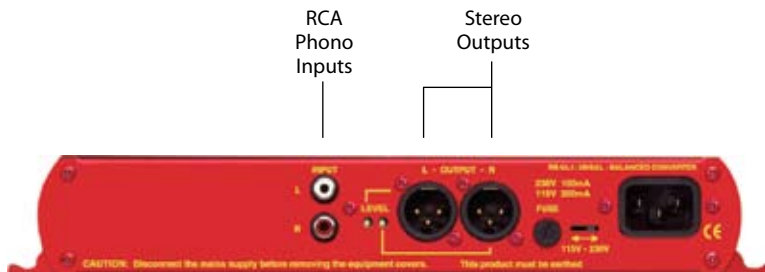

Output Level Adjustment

Fig 1-4: RB-UL1 Rear Panel.

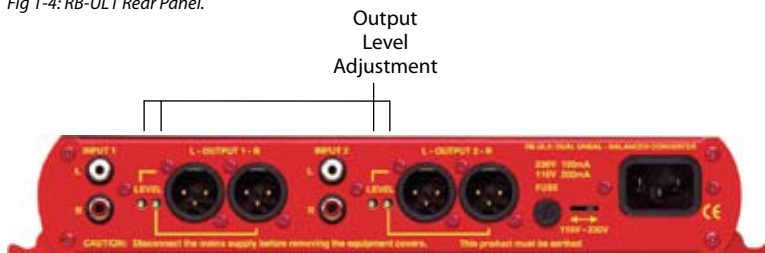

RCA Phono Inputs

Stereo Balanced Outputs

Fig 1-5: RB-UL2 Rear Panel.

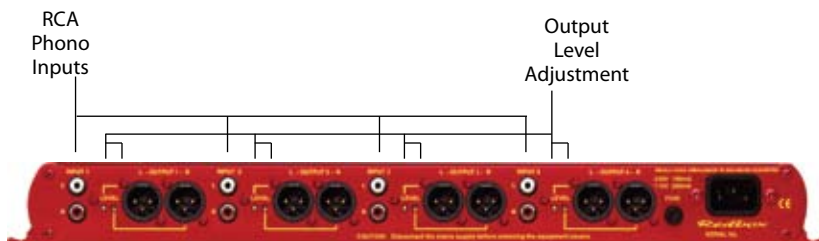

Stereo Balanced Outputs

Fig 1-6: RB-UL4 Rear Panel.



RCA Phono Inputs (Left and Right)

The stereo left and right RCA inputs are unbalanced and have an impedance of 10k Ω . They are routed to the stereo balanced XLR 3 pin output connectors.

Outputs (Left and Right)

The XLR 3 pin output plug connectors are electronically balanced with an output impedance of <50 Ω . They have the following connections:

Pin 1: Screen

Pin 2: Phase

Pin 3: Non-phase

Output Level Adjustment

The output gain can be individually adjusted for left and right channels through pre-set potentiometers which are accessible through the rear panel. The gain range of the unbalanced to balanced converter is -15dBu to +15dBu ref -15dBu into the unbalanced input.



MATCHING CONVERTERS - RB-UL1, RB-UL2, RB-UL4



Technical Specifications

Audio Specifications

Maximum Input Level:	+28dBu
Input Impedance:	>10k Ω
Output Impedance:	<50 Ω
Maximum Output Level:	+28dBu
Distortion:	0.01% THD @ 1kHz ref +8dB output
Noise:	-100dB unity gain, ref +8dB output
Common Mode Rejection:	>66dB typically
Frequency Response:	20Hz to 20kHz \pm 0.1dB (600 Ω load, ref 1kHz)
Gain Range:	Balanced output: -15dBu to 15dBu, ref -15dBu into unbalanced RCA input

Connections

Inputs:	2, 4 (RB-UL2) or 8 (RB-UL4) x RCA phono (unbalanced)
Outputs:	2, 4 (RB-UL2) or 8 (RB-UL4) x XLR 3 pin male (balanced)
Mains Input:	Filtered IEC, 110V-120V, or 220-240V switchable, fused, 6W maximum
Fuse Rating:	Anti-surge fuse 100mA 20 x 5mm (230VAC) Anti-surge fuse 250mA 20 x 5mm (115VAC)

Equipment Type

RB-UL1:	Single stereo unbalanced to balanced converter
RB-UL2:	Dual stereo unbalanced to balanced converter



RB-UL4:	Quad stereo unbalanced to balanced converter
---------	--



Physical Specifications

RB-UL1 & RB-UL2:

Dimensions (Raw):	28cm (W) x 10.8cm (D) x 4.2cm (H) (1U)		
Dimensions (Boxed):	36cm (W) x 20.5cm (D) x 6cm (H)		
Weight RB-UL1:	Nett: 1.00kg	Gross: 1.45kg	
Weight RB-UL2:	Nett: 1.05kg	Gross: 1.5kg	

RB-UL4:

Dimensions (Raw):	48cm (W) x 10.8cm (D) x 4.2cm (H) (1U)		
Dimensions (Boxed):	53cm (W) x 20.5cm (D) x 6cm		
Weight:	Nett: 1.3kg	Gross: 1.9kg	

2 RB-LU4 Quad Stereo Balanced To Unbalanced Converter

Introduction



Fig 2-1: RB-LU4 Front Panel.

The RB-LU4 is a quad stereo unit for interfacing professional balanced equipment to domestic, or semi-pro unbalanced line levels.

All connections are on the rear panel. The eight XLR-3 electronically balanced inputs have an impedance of $20k\Omega$ bridging and are routed to eight unbalanced RCA phono outputs with an output impedance of $<50\Omega$.

The output gain can be individually adjusted for left and right channels by using pre-set potentiometers accessible through the rear panel. An LED power indicator is situated on the front panel, which displays the power supply connection.



2

MATCHING CONVERTERS



MATCHING CONVERTERS - RB-LU4

System Block Diagram

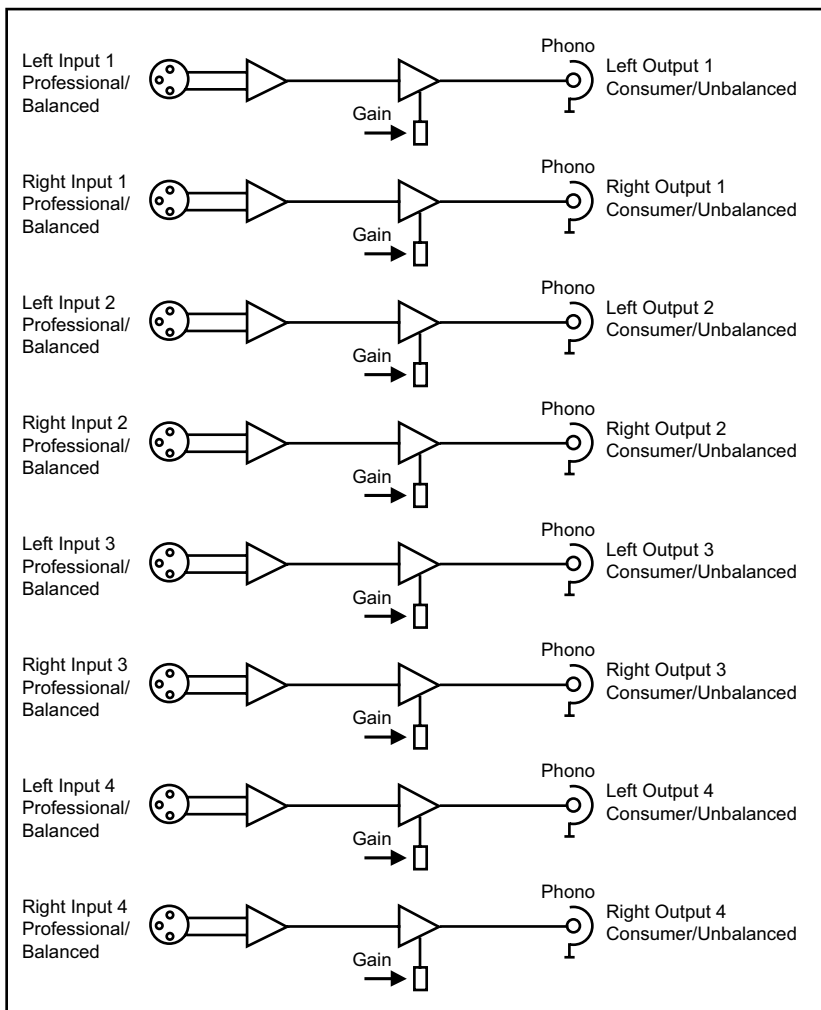

Fig 2-2: RB-LU4 Block Diagram.

Rear Panel Connections and Operation

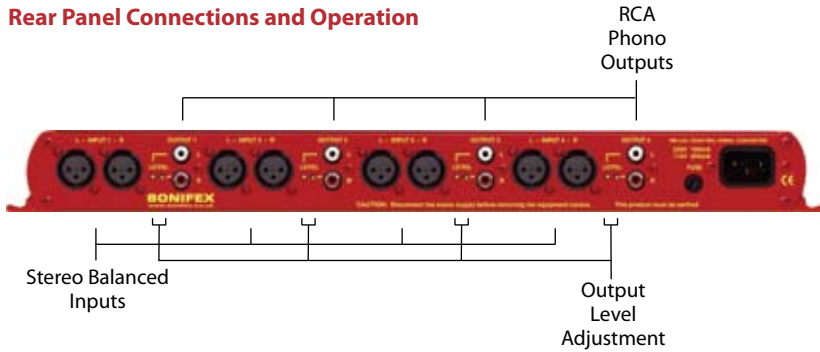

Fig 2-3: RB-LU4 Rear Panel.

Inputs 1-4 (Left and Right)

The XLR 3 pin sockets used for the left and right channel inputs of Input 1 are electronically balanced and have an impedance of 20k Ω bridging. They are routed to an unbalanced RCA (phono) output with an output impedance of <50 Ω . Each XLR has the following connections:

- Pin 1: Screen
- Pin 2: Phase
- Pin 3: Non-phase

RCA Phono Outputs 1-4 (Left and Right)

These RCA (phono) outputs are unbalanced and have an output impedance of <50 Ω .

Output Level Adjustment

The output gain can be individually adjusted for left and right channels through pre-set potentiometers which are accessible through the rear panel. The gain of the balanced to unbalanced converter is variable within a range of -28dBu to +15dBu ref. -15dBu into the balanced input.



Technical Specifications

Audio Specifications

Maximum Input Level:	+28dBu
Input Impedance (XLR):	>20k Ω balanced bridging
Output Impedance (RCA) :	<50 Ω
Maximum Output Level:	+22dBu
Distortion:	0.01% THD @ 1kHz, ref +8dBu output
Noise:	-100dB, unity gain, ref +8dBu output
Common Mode Rejection:	>66dB typically
Frequency Response:	20Hz to 20kHz \pm 0.1dB (600 Ω load, ref 1kHz)
Gain Range:	Unbalanced Output: -28dBu to +15dBu, ref -15dBu into balanced XLR input

Connections

Inputs:	8 x XLR 3 pin female (Balanced)
Outputs:	8 x RCA phono (Unbalanced)
Mains Input:	Filtered IEC, 110V-120V, or 220-240V switchable, fused, 6W maximum
Fuse Rating:	Anti-surge fuse 100mA 20 x 5mm (230VAC) Anti-surge fuse 250mA 20 x 5mm (115VAC)

Equipment Type

RB-LU4: Quad stereo balanced to unbalanced converter



Physical Specifications

Dimensions (Raw):	48cm (W) x 10.8cm (D) x 4.2cm (H) (1U)
Dimensions (Boxed):	53cm (W) x 20.5cm (D) x 6cm (H)
Weight:	Nett: 1.3kg Gross: 1.9kg

3 RB-BL2 Single & RB-BL4 Dual Bi-Directional Matching Converter

Introduction



Fig 3-1: RB-BL2 Front Panel.



Fig 3-2: RB-BL4 Front Panel.

The RB-BL2 is a bi-directional stereo unit for interfacing domestic, or semi-pro unbalanced equipment to professional balanced line levels, and vice-versa. The RB-BL4 has dual bi-directional stereo capability.

All connections are on the rear panel. The XLR-3 electronically balanced inputs have an impedance of 20k Ω bridging and are routed to unbalanced RCA (phono) outputs with an output impedance of <50 Ω .

The RCA unbalanced inputs have an impedance of 10k Ω bridging and are routed to balanced XLR-3 outputs with an output impedance of <50 Ω .

The output gain can be individually adjusted for left and right channels by using pre-set potentiometers accessible through the rear panel. An LED power indicator on the front panel displays the power supply connection.



3

MATCHING CONVERTERS



MATCHING CONVERTERS - RB-BL2 & RB-BL4

System Block Diagram

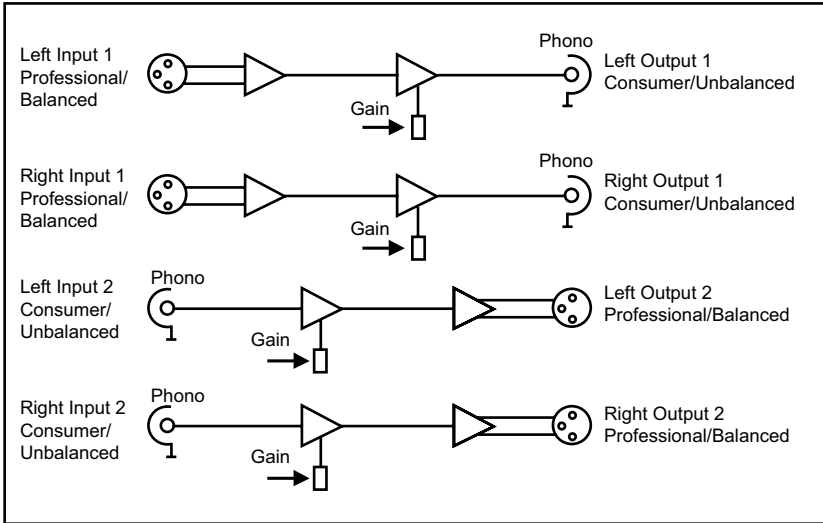

Fig 3-3: RB-BL2/BL4 Block Diagram Single Stereo Channel.

(Note RB-BL4 contains 2 of these circuits)

Rear Panel Connections and Operation

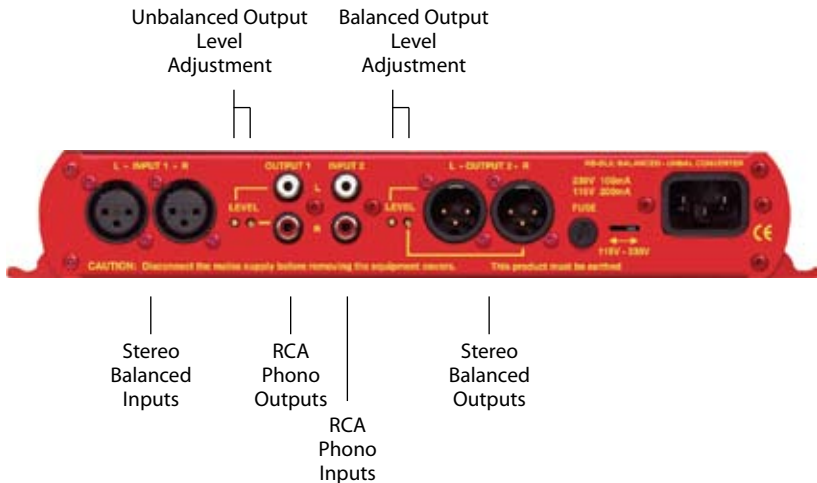

Fig 3-4: RB-BL2 Rear Panel.

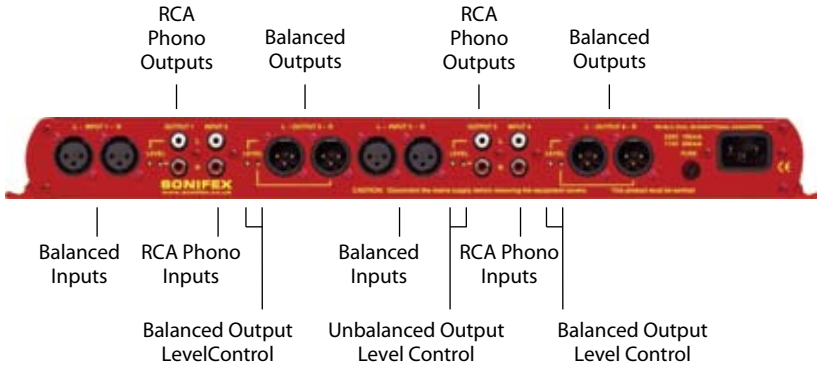

Fig 3-5: RB-BL4 Rear Panel.

Balanced to Unbalanced Connections

Inputs 1 (& 3) (Left & Right)

The XLR 3 pin sockets used for the left and right channel signals of Inputs 1 & 3 are electronically balanced and have an impedance of 20kΩ bridging. They are routed to unbalanced RCA (phono) outputs with an output impedance of <50Ω. Each XLR has the following connections:

- Pin 1: Screen.
- Pin 2: Phase.
- Pin 3: Non-phase.

RCA Phono Outputs 1 (& 3) (Left & Right)

These RCA (phono) outputs are unbalanced and have an output impedance of <50Ω.

Output Level Adjustment

The output gain can be individually adjusted for left and right channels through pre-set potentiometers which are accessible through the rear panel. The gain of the balanced to unbalanced converter is variable within a range of 0dBu to -28dBu ref -0dBu into the balanced input.

Unbalanced to Balanced Connections

RCA Phono Inputs 2 (& 4) (Left & Right)

The left and right RCA inputs 2 & 4 are unbalanced and have an impedance of 10kΩ. They are routed to the balanced XLR 3 pin outputs 2 & 4.

Outputs 2 (& 4) (Left & Right)

The XLR 3 pin output plug connectors are electronically balanced with an output impedance of <50Ω. They have the following connections:

- Pin 1: Screen.
- Pin 2: Phase.
- Pin 3: Non-phase.

3 MATCHING CONVERTERS



MATCHING CONVERTERS - RB-BL2 & RB-BL4

Technical Specifications

Audio Specifications

Maximum Input Level:	+28dBu
Maximum Output Level:	+28dBu
Input Impedance (RCA) :	>10k Ω unbalanced
Input Impedance (XLR) :	>20k Ω balanced bridging
Output Impedance (RCA) :	<50 Ω
Output Impedance (XLR) :	<50 Ω
Distortion:	0.01% THD @ 1kHz, ref +8dBu output
Noise:	-100dB, unity gain, ref +8dBu output
Common Mode Rejection:	>66dB typically
Frequency Response:	20Hz to 20kHz \pm 0.1dB (600 Ω load, ref 1kHz)
Gain Range:	Unbalanced Output: -28dBu to +15dBu, ref -15dBu into balanced XLR input
Gain Range:	Balanced Output: -15dBu to +15dBu, ref -15dBu into unbalanced RCA input

Connections

Inputs:	2 (4 on RB-BL4) x XLR 3 pin female (balanced), 2 (4 on RB-BL4) x RCA phono (unbalanced)
Outputs:	2 (4 on RB-BL4) x XLR 3 pin male (balanced), 2 (4 on RB-BL4) x RCA phono (unbalanced)
Mains Input:	Filtered IEC, 110V-120V, or 220-240V switchable, fused, 6W maximum
Fuse Rating:	Anti-surge fuse 100mA 20 x 5mm (230VAC) Anti-surge fuse 250mA 20 x 5mm (115VAC)

Equipment Type

RB-BL2: Single stereo bi-directional matching converter



RB-BL4: Dual stereo bi-directional matching converter



Physical Specification

RB-BL2:

Dimensions (Raw):	28cm (W) x 10.8cm (D) x 4.2cm (H) (1U)
Dimensions (Boxed):	36cm (W) x 20.5cm (D) x 6cm (H)
Weight:	Nett: 1.0kg Gross: 1.4kg

RB-BL4:

Dimensions (Raw)	48cm (W) x 10.8cm (D) x 4.2cm (H) (1U)
Dimensions (Boxed)	53cm (W) x 20.5cm (D) x 6cm (H)
Weight	Nett: 1.3kg Gross: 1.9kg

4 RB-PA2 Dual Stereo RIAA Phono Amplifier

Introduction



Fig 4-1: RB-PA2 Front Panel.

The RB-PA2 is a dual stereo RIAA equalised phono amplifier. This record player preamp amplifies the small signal from your pick up cartridge (either moving magnet or high output moving coil magnetic) and provides the necessary RIAA equalisation required for vinyl records, to match it to a line input of your mixer, or amplifier. It uses a clean RIAA response making it ideal for use with broadcast turntables and DJ decks and where vinyl records are being archived to CD for high quality transfers, or for converting albums to mp3.

It operates with phono cartridges with a nominal output of 1mV to 25mV and has been specifically tested to work with the Technics SL-1200™ and 1210™ range of turntables. Quality high specification components have been used together with low noise, fast acting operational amplifiers to produce a superbly transparent signal path. Additionally, the RB-PA2 runs without a rumble filter to produce a powerful bass response.

The RB-PA2 is a dual stereo unit to interface up to two turntables. The inputs are phono connectors with Neutrik XLR connectors for the balanced outputs, which may be wired unbalanced if required. Output gain is individually adjustable for left and right channels in the range 35dB to 65dB by using pre-set potentiometers. Frequency response is held within 0.5dB of the RIAA curve and noise is typically better than -84dB RMS A weighted at 40dB gain.

System Block Diagram

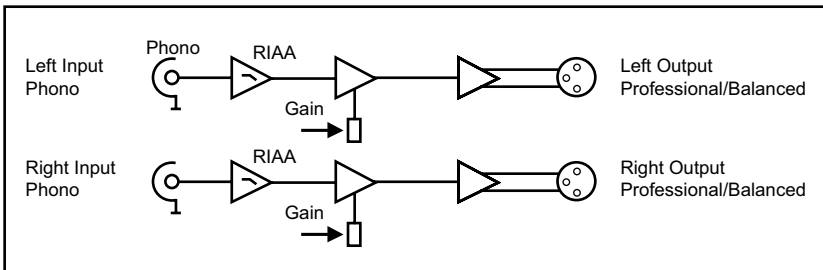

Fig 4-2: RB-PA2 Block Diagram For a Single Stereo Channel.

MATCHING CONVERTERS - RB-PA2

4

MATCHING CONVERTERS



MATCHING CONVERTERS - RB-PA2

Rear Panel Connections and Operation

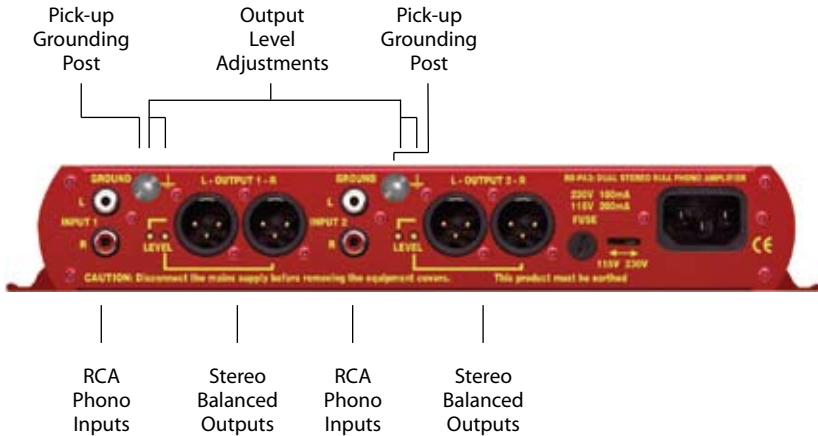

Fig 4-3: RB-PA2 Rear Panel.

RCA Phono Inputs (Left and Right)

The stereo left and right RCA inputs are unbalanced and have an impedance of 47k Ω . They are routed to the stereo balanced XLR 3 pin output connectors.

Outputs (Left and Right)

The XLR 3 pin output plug connectors are electronically balanced with an output impedance of 50Ω. They have the following connections:

- Pin 1: Screen
- Pin 2: Phase
- Pin 3: Non-phase

Output Level Adjustment

The output gain can be individually adjusted for left and right channels through pre-set potentiometers which are accessible through the rear panel. The gain range of each channel is adjustable between 30dB gain and 58dB gain.

Pick-up Grounding Post

This acts as an earth ground connection to connect to a turntable pick-up ground point.

Technical Specifications

Audio Specifications

Maximum Input Level:	+28dBu
Input Impedance:	>47kΩ
Input Sensitivity Range:	1mV to 25mV (ref 1kHz)
Maximum Output Level:	+28dBu
Output Impedance:	<50Ω
Output Gain Range:	Adjustable 38dB to 58dB gain via 4 multi-turn pots
Crosstalk:	Better than -80dBu at 1kHz
Frequency Response:	10Hz-150kHz (-3dB)
RIAA Accuracy:	Within 0.5dB of RIAA curve
Distortion:	0.01% THD @ 1kHz, ref +8dBu output
Noise:	-77dB (CCIR Q-Pk, 20Hz-20kHz)
Headroom:	27dB for 3mV input
Dynamic Range:	90dB

Connections

Inputs:	4 x RCA phono (unbalanced)
Outputs:	4 x XLR 3 pin male (balanced)
Earth Tag:	Grounding turret tag
Mains Input:	Filtered IEC, 110V-120V, or 220-240V switchable, fused 6W maximum
Fuse Rating:	Anti-surge fuse 100mA 20 x 5mm (230VAC) Anti-surge fuse 250mA 20 x 5mm (115VAC)

Equipment Type

RB-PA2: Dual stereo phono amplifier and RIAA gram amplifier



Physical Specifications

Dimensions (Raw):	28cm (W) x 10.8cm (D) x 4.2cm (H) (1U)
Dimensions (Boxed):	36cm (W) x 20.5cm (D) x 6cm (H)
Weight RB-PA2	Nett: 1.1kg Gross: 1.5kg



5 MATCHING CONVERTERS

5 RB-LI2 Stereo Line Isolation Unit

Introduction



Fig 5-1: RB-LI2 Front Panel.

The RB-LI2 stereo line isolation unit is used to isolate audio signals from inter area ground hum loops, which could be caused by equipment being powered by different mains power supplies, or different phases on the same supply. The input and output are connected together through a transformer, which has internal jumpers allowing the outputs to be balanced about ground.

There is also a loop-through output, so that the RB-LI2 can be inserted into a line, forming a transformer balanced distribution point.

This unit is useful where audio is required to be driven over a relatively long length of cable. By isolating the signal using transformers, ground loop currents that can be present in non-isolated signals, are eradicated completely.

System Block Diagram

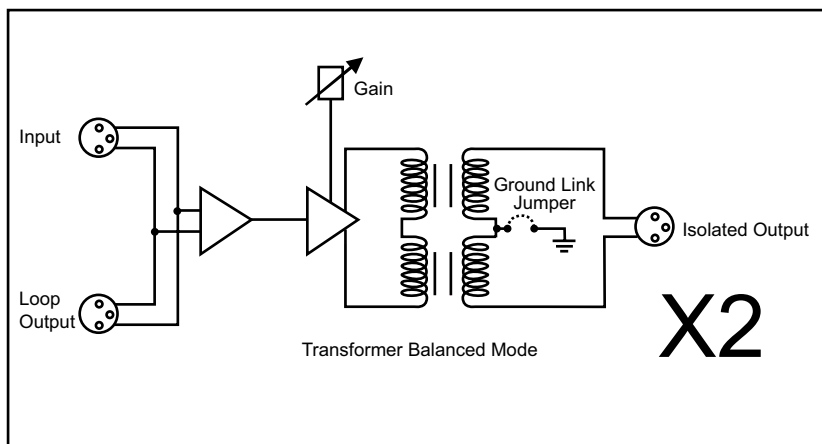

Fig 5-2: RB-LI2 System Block Diagram.

Rear Panel Connections and Operation

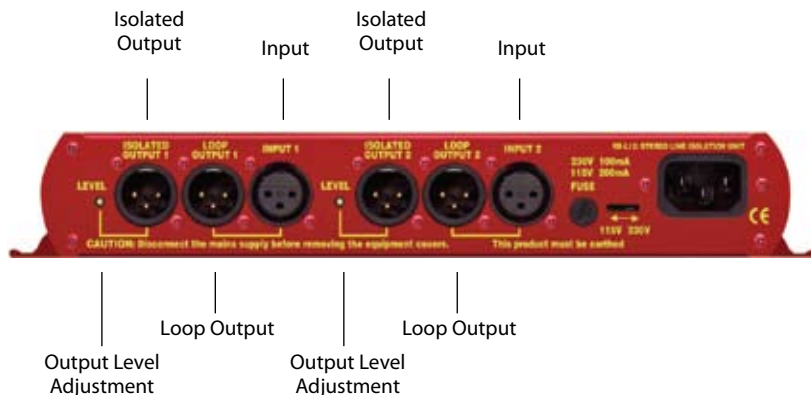

Fig 5-3: RB-LI2 Rear Panel.

Inputs

There are 2 input XLR 3 pin sockets. They have the following connections:

- Pin 1: Screen
- Pin 2: Phase
- Pin 3: Non-phase

Isolated Outputs

Each of the 2 inputs has a corresponding isolated output, an XLR 3 pin plug with the following connections:

- Pin 1: Screen
- Pin 2: Phase
- Pin 3: Non-phase

Loop Outputs

Each of the 2 inputs has a corresponding loop-through output, an XLR 3 pin plug with the following connections:

- Pin 1: Screen
- Pin 2: Phase
- Pin 3: Non-phase

Output Level Adjustment

The isolated outputs can be individually adjusted using pre-set potentiometers, which are accessible through the rear panel. The gain range of the stereo line isolation unit is -15dB to +13.5dB (28.5dB).



5 MATCHING CONVERTERS



MATCHING CONVERTERS - RB-LI2

Internal Jumpers

The unit has jumpers that are used to balance the output about ground. By default these are not fitted when the unit leaves the factory.

To get inside the RB-LI2, first ensure that it has been disconnected from the mains power and that the mains IEC lead to the unit has been removed. Observing anti-static precautions, undo the four-crosshead screws on the back panel at the far left and far right of the panel (2 at each end). Also undo the small brass screws, which hold the top and bottom panels to the rear panel. The rear panel should slide backwards out of the unit together with the main circuit board.

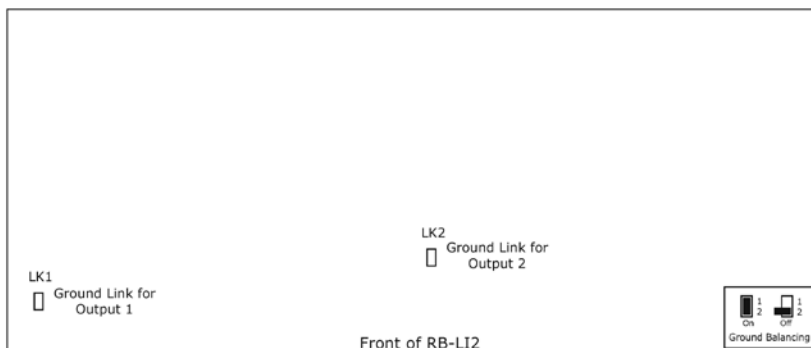

Fig 5-4: RB-LI2 Jumper Positions on the PCB.

Technical Specifications

Audio Specification

Output Impedance:	<150Ω
Frequency Response:	10Hz to 36kHz ±0.5dB
Common Mode Rejection:	<64dB
Distortion:	0.5% THD @ 40Hz, ref +17dBu output
Noise:	-100dB unity gain ref +8dB
Gain Range:	-15dB to +13.5dB (28.5dB)

Connections

Inputs:	2 x XLR 3 pin female
Isolated Outputs:	2 x XLR 3 pin male
Loop Outputs:	2 x XLR 3 pin male
Fuse Rating:	Anti-surge fuse 100mA 20 x 5mm (230VAC) Anti-surge fuse 250mA 20 x 5mm (115VAC)

Equipment Type

RB-LI2:	Stereo line isolation unit
---------	----------------------------



Physical Specifications

Dimensions (Raw):	28cm (W) x 10.8cm (D) x 4.2cm (H) (1U)
Dimensions (Boxed):	36cm (W) x 20.5cm (D) x 6cm (H)
Weight:	Nett: 1.10kg Gross: 1.50kg

6 RB-PLI6 6 Way Mono Passive Line Isolation Unit

Introduction



Fig 6-1: RB-PLI6 Front Panel.

The RB-PLI6 6 way mono passive line isolation unit is used to isolate audio signals from inter area ground hum loops, which could be caused by equipment being powered by different mains power supplies or phases on the same supply.

The input and output are connected together through a transformer and the unit has internal jumpers allowing the inputs and/or outputs to be balanced about ground. The unit requires no mains power for operation.

This unit is useful where audio is required to be driven over a relatively long length of cable. By isolating the signal using transformers, ground loop currents that can be present in non-isolated signals, are eradicated completely.

System Block Diagram

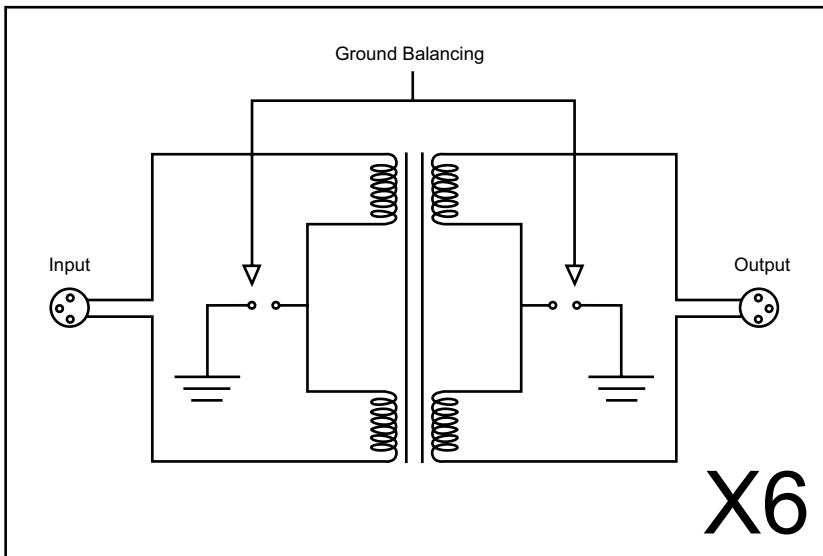
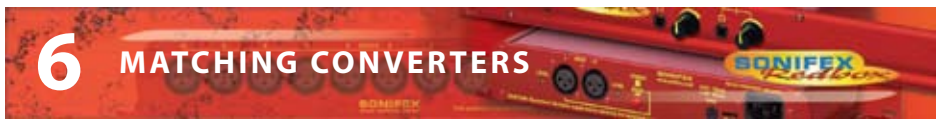

Fig 6-2: RB-PLI6 System Block Diagram.

6

MATCHING CONVERTERS



MATCHING CONVERTERS - RB-PLI6

Rear Panel Connections and Operation

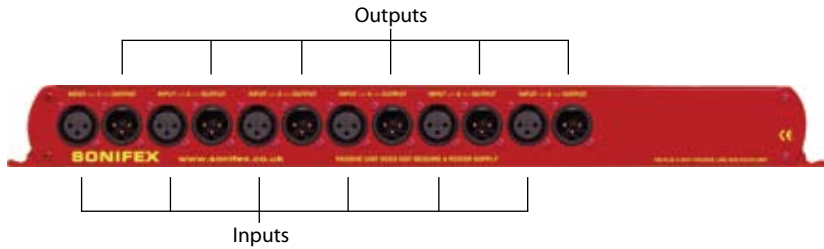

Fig 6-3: RB-PLI6 Rear Panel.

Inputs

There are 6 off XLR 3 pin socket inputs. They have the following connections:

- Pin 1: Screen
- Pin 2: Phase
- Pin 3: Non-phase

Outputs

There are 6 off XLR 3 pin plug outputs. They have the following connections:

- Pin 1: Screen
- Pin 2: Phase
- Pin 3: Non-phase

Ground-link Internal Jumpers

The unit has jumpers that are used to balance either the input, or the output, about ground. By default these are not fitted when the unit leaves the factory.

To get inside the RB-PLI6, observing anti-static precautions, undo the four crosshead screws on the back panel at the far left and far right of the panel (2 at each end). Also undo the small brass screws, which hold the top and bottom panels to the rear panel. The rear panel should slide backwards out of the unit together with the main circuit board.

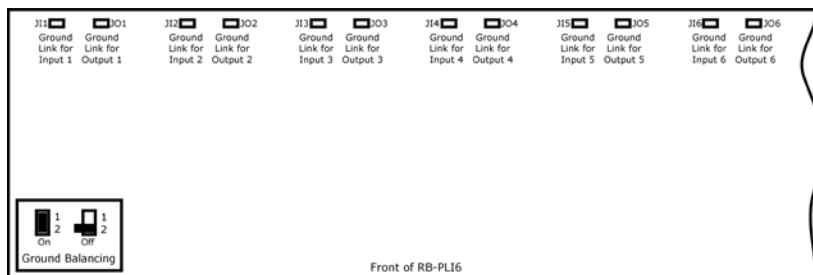

Fig 6-4: RB-PLI6 Ground-link Jumper Settings.

Technical Specifications

Audio Specification

Output Impedance:	<150Ω
Distortion:	0.5% THD @ 40Hz, ref +17dBu output
Common Mode Rejection:	<64dB typically
Frequency Response:	10Hz to 36kHz ±0.5dB

Connections

Inputs:	6 x XLR 3 pin female (balanced)
Outputs:	6 x XLR 3 pin male (balanced)

Equipment Type

RB-PLI6:	6 way mono passive line isolation unit
----------	--



Physical Specifications

Dimensions (Raw):	48cm (W) x 10.8cm (D) x 4.2cm (H-1U nominally)		
Dimensions (Boxed):	53cm (W) x 20.5cm (D) x 6cm		
Weight:	Nett: 1.5kg	Gross: 1.9kg	



7 AUDIO DISTRIBUTION AMPLIFIERS



7 RB-DA6 & RB-DA6G 6 Way Stereo Distribution Amplifier

Introduction



Fig 7-1: RB-DA6 Front Panel.



Fig 7-2: RB-DA6G Front Panel.

The RB-DA6 and RB-DA6G are high performance 6 way stereo analogue distribution amplifiers for splitting a source to a number of different outputs. The RB-DA6 has 1 stereo input and 6 stereo outputs with gain control on both inputs. It can also be configured so that 1 mono input can be distributed to 12 outputs. As a variant of the RB-DA6, the RB-DA6G, has an individual gain control on every output.

The XLR-3 inputs and outputs are electronically balanced and can be wired unbalanced. Each output is individually buffered so that a short circuit on one won't affect the others. The outputs can be wired unbalanced.

The RB-DA6 has master left and right gain controls which are pre-set potentiometers accessible through the front panel. On the RB-DA6G each channel has an individual output gain control (normalising) which are all pre-set potentiometers, also accessible through the front panel. The 1-12 mono, 1-6 stereo switch is recessed on the front panel to prevent accidental knocking. An LED power indicator on the front panel displays the power supply connection.

System Block Diagrams

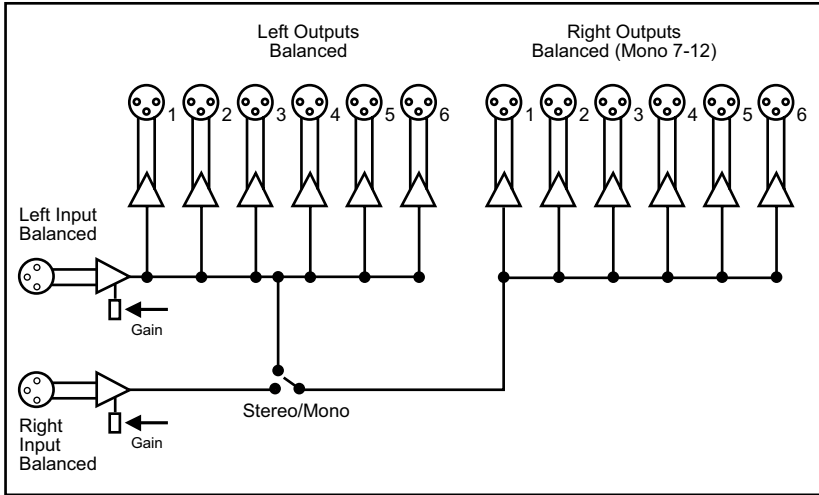

Fig 7-3: RB-DA6 Block Diagram.

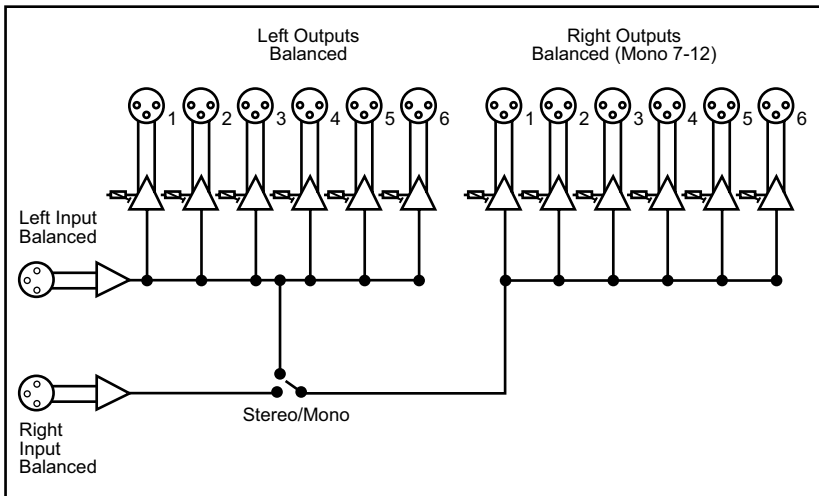

Fig 7-4: RB-DA6G Block Diagram.



AUDIO DISTRIBUTION AMPLIFIERS - RB-DA6 & RB-DA6G

7 AUDIO DISTRIBUTION AMPLIFIERS



Connections and Operation



Fig 7-5: RB-DA6 & RB-DA6G Rear Panel.

Inputs (Left and Right)

The XLR-3 input connectors can take balanced professional levels, or unbalanced by using the front panel gain controls, and by connecting the non-phase to the signal ground. The input can be configured as either a stereo input with six stereo outputs or a mono input with twelve outputs. The XLR 3 pin input has the following connections:

- Pin 1: Screen
- Pin 2: Phase
- Pin 3: Non-phase

Stereo Outputs 1-6 (Mono Outputs 1-12)

The XLR 3 pin outputs are electronically balanced, and can be wired unbalanced. Each output is individually buffered so that a short circuit on one output will not affect the others. They have the following connections:

- Pin 1: Screen
- Pin 2: Phase
- Pin 3: Non-phase

Input Gain Control (RB-DA6)

The input gain on the RB-DA6 can be varied -8dB to 18dB by adjusting the pre-set potentiometers. These are accessible through the holes in the front panel. The RB-DA6 has separate left and right master gain controls.

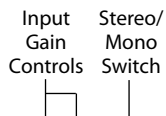

Fig 7-6: RB-DA6 Front Panel.

Output Gain Control (RB-DA6G)

The output gain on the RB-DA6G can be varied -8dB to 18dB by adjusting the pre-set potentiometers. These are accessible through the holes in the front panel. The RB-DA6G has output gain controls on every output.

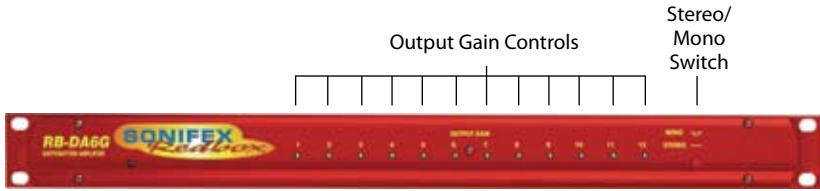

Fig 7-7: RB-DA6G Front Panel.

Stereo/Mono Operation

The mode of operation may be switched between a stereo distributed channel to 6 stereo channels, and a mono channel to 12 mono channels, by the push button on the front panel, which is recessed to prevent accidental switching.

Technical Specifications

Audio Specifications

Input Impedance	>20kΩ bridging
Output Impedance	<50Ω
Maximum Input Level	+28dBu
Maximum Output Level	+28dBu
Frequency Response	20Hz to 20kHz ± 0.1 dB (600Ω load, ref 1 kHz)
Gain Range	Adjustable 8dB loss to 18dB gain
Common Mode Rejection	>66dB typically
Distortion	0.01% THD @ 1kHz, ref +8dBu output
Noise	-100dB unity gain ref +8dB (RB-DA6) -88dB unity gain ref +8dB (RB-DA6G)

Connections

Inputs	2 x XLR 3 pin female (Balanced, can be unbalanced)
Outputs	12 x XLR 3 pin male (Balanced, can be unbalanced)
Mains Input	Filtered IEC, 110V-120V, or 220-240V, fused, 6W maximum
Fuse Rating:	Anti-surge fuse 100mA 20 x 5mm (230VAC) Anti-surge fuse 250mA 20 x 5mm (115VAC)

Equipment Type

RB-DA6:	6 way stereo distribution amplifier
RB-DA6G:	6 way stereo distribution amplifier with output gain



Physical Specifications

Dimensions (Raw):	48cm (W) x 10.8cm (D) x 4.2cm (H) (1U)
Dimensions (Boxed):	53cm (W) x 20.5cm (D) x 6cm (H)
Weight:	Nett: 1.3kg Gross: 1.9kg





8 RB-DA4x5 4 Input 4 x 5 Output Distribution Amplifier/Mixer

Introduction

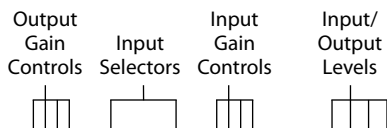

Fig 8-1: RB-DA4x5 Front Panel.

The RB-DA4x5 is a 1U rack-mount combined distribution amplifier and mixer. It has 4 mono analogue audio inputs on female XLR and 4 groups of 5 outputs on 15 way D-type connectors. Each output group has a five way front-panel DIP switch assigned to it which is used to select the input(s) to send to the output group. This enables each of the four inputs, and a 1kHz 0dBu tone, to be mixed to the output group.

The inputs and outputs are electronically balanced and can be wired unbalanced. Each input has adjustable gain using a preset potentiometer, providing a gain range of -8dB to +18dB. Each output is individually buffered so that a short circuit on one output will not affect the others. The output gain of each group can similarly be adjusted between -8dB and +18dB using preset potentiometers.

The DIP switch settings and gain controls are recessed beneath a front-mounting screw-on cover so that settings can not be accidentally altered, for secure applications. Four bright front-panel signal present LEDs show the levels of either the inputs or the output groups by pressing the AUDIO PRESENCE button. The LEDs will show green illumination from -12dBu through to 0dBu, amber from 0dBu through to +6dBu and red for inputs and outputs at +6dBu and over.

System Block Diagram

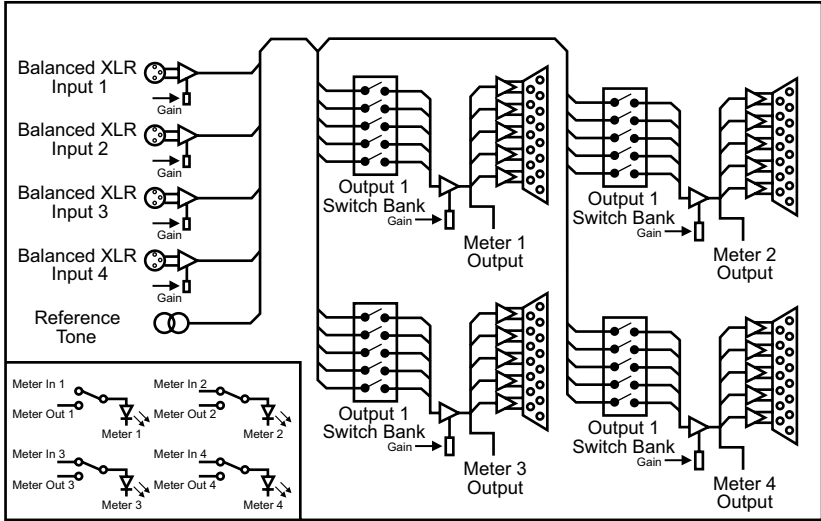

Fig 8-2: RB-DA4x5 Block Diagram.

Rear Panel Connections and Operation

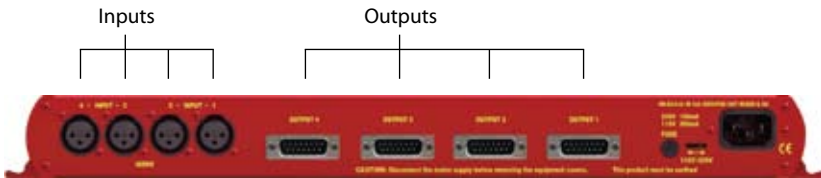

Fig 8-3: RB-DA4x5 Rear Panel.

Audio Inputs 1-4

The XLR 3 pin sockets used for the audio inputs are electronically balanced and have an impedance of 20kΩ bridging. They are routed to the switch matrix. Each XLR has the following connections:

- Pin 1: Screen
- Pin 2: Phase
- Pin 3: Non-phase





D-Type Audio Output Groups 1-4

Each output group connector has 5xDA driven balanced audio outputs on a D-type connector outputs each with an output impedance of $<50\Omega$.

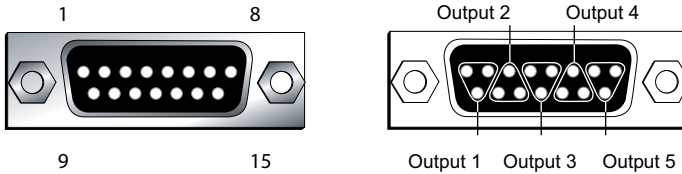

Fig 8-4: RB-DA4x5 Audio Output Group 15-Way D-Type Plug.

Function	Output 1	Output 2	Output 3	Output 4	Output 5
Out + Pin No.	1	3	4	6	7
Out - Pin No.	9	10	12	13	15
Signal Ground Pin No.	2	11	5	14	8

Fig 8-5: RB-DA4x5 Pinout for Audio Output Group Connector.

Monitor LEDs

There are 4 LEDs on the front panel that indicate the relative levels of the audio signals at the inputs or outputs. A pushbutton switch on the front panel toggles the function of these LEDs between input and output. These LEDs indicate the levels of the signals by illuminating green for signals between -12 and 0dBu , illuminating yellow for signals between 0 and $+6\text{dBu}$, and illuminating red for signals over $+6\text{dBu}$.

Input Level Adjustment

The gain for each input can be adjusted through pre-set potentiometers that are accessible from behind the removable plate on the front panel. The gain of each balanced input is variable within a range of -8dB to $+18\text{dB}$ into the router input.

Output Level Adjustment

The gain for each output group can be adjusted through pre-set potentiometers that are accessible from behind the removable plate on the front panel. The gain of each output group is variable within a range of -8dB to $+18\text{dB}$ from the router output.

Routing Selection

Each output group is capable of selecting its signal from any combination of inputs and the test tone. Set the appropriate dip-switch for that group & that input to the on position to include the signal in the group's output.

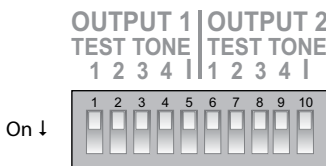

Fig 8-6: RB-DA4x5 Routing Selection Switch.

Function	Group 1 Routing	Group 2 Routing	Group 3 Routing	Group 4 Routing
Input 1	SW1-1 On	SW1-6 On	SW2-1 On	SW2-6 On
Input 2	SW1-2 On	SW1-7 On	SW2-2 On	SW2-7 On
Input 3	SW1-3 On	SW1-8 On	SW2-3 On	SW2-8 On
Input 4	SW1-4 On	SW1-9 On	SW2-4 On	SW2-9 On
Test Tone	SW1-5 On	SW1-10 On	SW2-5 On	SW2-10 On

Fig 8-7: RB-DA4x5 Routing Selection Switch Functions.

Alignment Test Tone

Each of the output groups has the capability of selecting a 1kHz, 0dBu test tone. This signal can be used as a reference to set the output gain levels. Once these values are known then the input gains can be set by providing a known tone to the input and adjusting the input gain to the required level. It is possible to use this test tone as a reference level for the input gain by adjusting the output gains to unity and then looping back any output to the input connector. The on-board oscillator is temperature sensitive and in cold conditions may take a short time to start oscillating. In any case you should always allow the unit to fully come to its normal operating temperature before adjusting the gains.

Technical Specifications

Audio Specifications

Maximum Input Level:	+28dBu
Input Impedance (XLR):	>20kΩ balanced bridging
Output Impedance:	<50Ω
Maximum Output Level:	+28dBu
Distortion:	0.01% THD @ 1kHz, ref +8dBu output
Noise:	-100dB, unity gain, ref +8dBu output
Common Mode Rejection:	>66dB typically
Frequency Response:	20Hz to 20kHz ±0.1dB (600Ω load, ref 1kHz)
Input Gain Range:	Adjustable 8dB loss to 18dB gain (channel 1-4 adjust)
Output Gain Range:	Adjustable 8dB loss to 18dB gain (group 1-4 adjust)

Connections

Inputs (4 x mono):	4 x XLR 3 pin female (Balanced)
Outputs (20 x mono):	4 x 15 way D-type (Balanced)
Mains Input:	Filtered IEC, 110V-120V, or 220-240V switchable, fused, 9W maximum
Fuse Rating:	Anti-surge fuse 100mA 20 x 5mm (230VAC) Anti-surge fuse 250mA 20 x 5mm (115VAC)

Equipment Type

RB-DA4x5: 4 input to 20 output distribution amplifier & mixer



Physical Specifications

Dimensions (Raw):	48cm (W) x 15.8cm (D*) x 4.2cm (H) (1U)
Dimensions (Boxed):	53cm (W) x 25.5cm (D*) x 6cm (H)
Weight:	Nett: 1.6kg Gross: 2.2kg

* Note that this product is deeper than standard redboxes.





9 RB-DDA6A 6 Way Stereo AES/EBU Digital Distribution Amplifier and RB-DDA6S 6 Way Stereo S/PDIF Digital Distribution Amplifier

Introduction



Fig 9-1: RB-DDA6A/S Front Panel.

24^{BIT}
192^{kHz}

The RB-DDA6A digital distribution amplifier is used for distributing digital audio data in AES/EBU format, repeating both the audio data and the status information of the input whilst re-normalising to standard digital audio levels.

It has a single XLR-3 female AES/EBU audio input which is distributed to 6 XLR-3 male AES/EBU outputs.

Applications include distributing audio from a digital mixing desk to multiple digital recorders, or feeding multiple studios with an output from a DAT machine.

It can accept input sample rates in the range of 30kHz - 100kHz, and bit rates of 16, 20 and 24 bit. So, it can be used for standard CD signal distribution at 16 bit 44.1kHz, as well as for high quality 24 bit 96kHz recording.

The RB-DDA6S digital distribution amplifier is similar to the RB-DDA6A except that it is used for distributing digital audio data in S/PDIF format.

It has a single S/PDIF audio input which is distributed to 6 x S/PDIF audio outputs at the same level and condition as the input signal. It can accept input sample rates in the range of 30kHz - 100kHz, and bit rates of 16, 20 and 24 bit.

Uses include audio distribution at 16 bit 44.1kHz from a consumer CD player to multiple digital recorders, distribution of high quality 24 bit 96kHz signals from digital mixing desks to recorders and connection of the output of, say, a DVD player to multiple studios.

System Block Diagrams

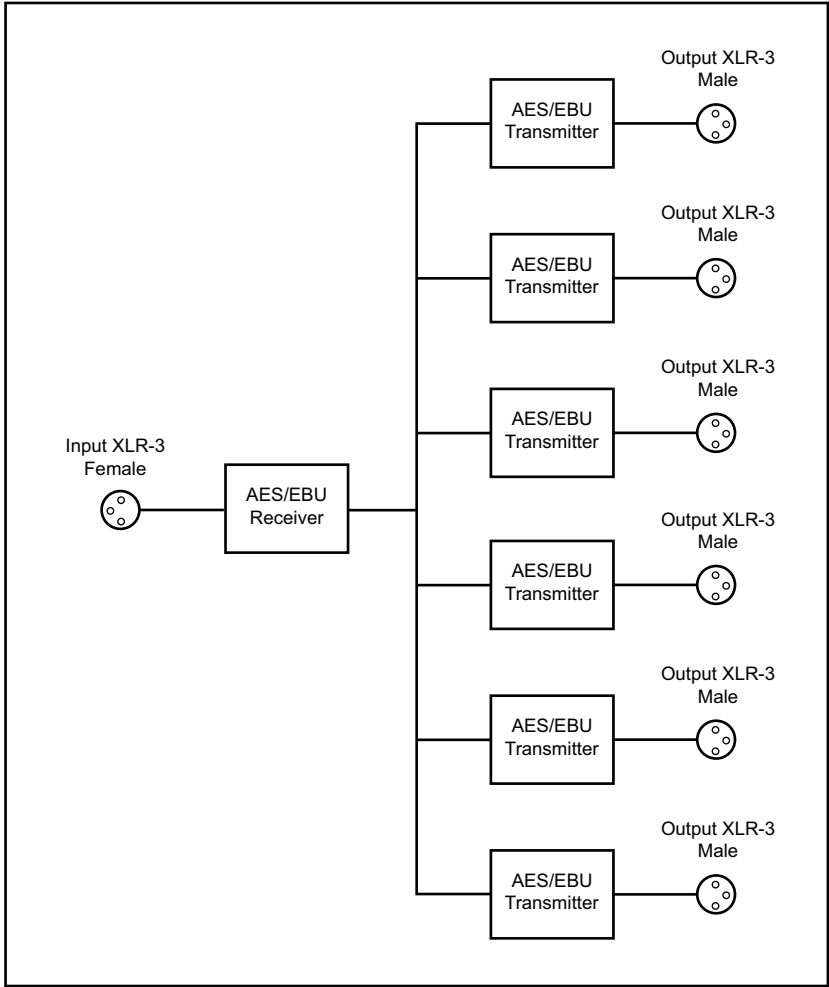

Fig 9-2: RB-DDA6A System Block Diagram.



AUDIO DISTRIBUTION AMPLIFIERS-RB-DDA6A & RB-DDA6S

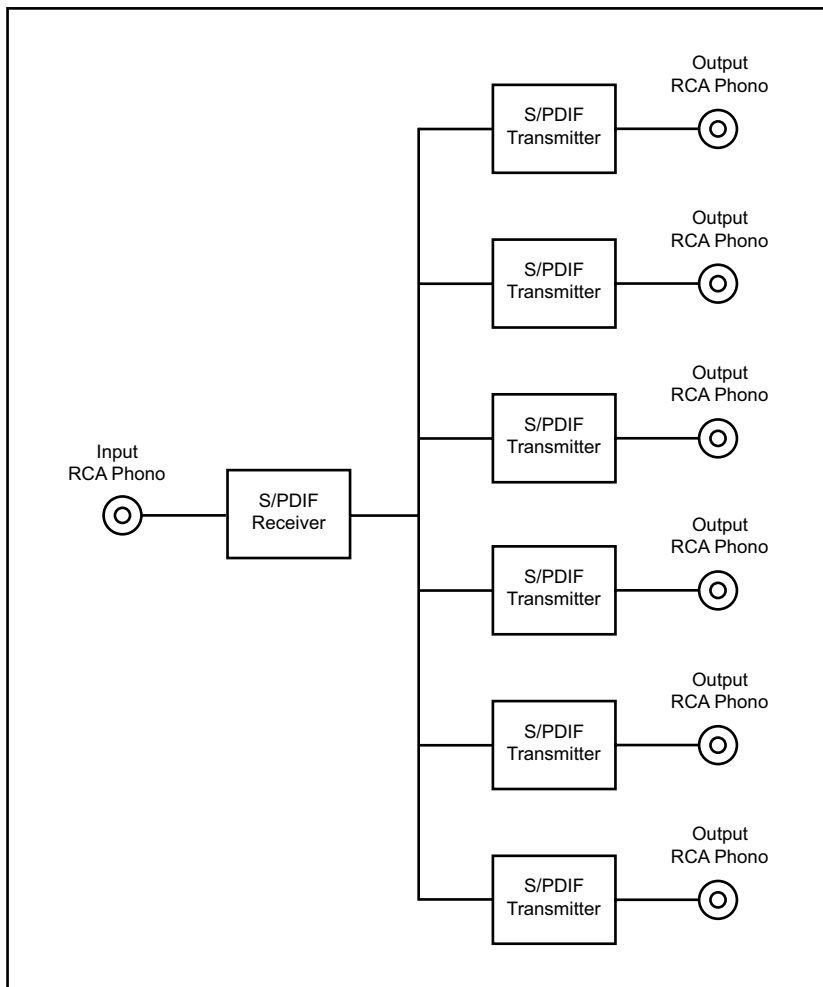

Fig 9-3: RB-DDA6S System Block Diagram.

Rear Panel Connections and Operations

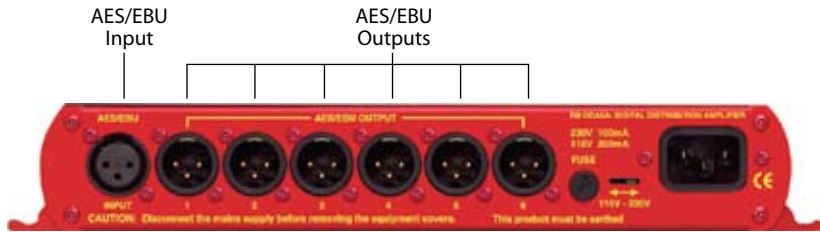

Fig 9-4: RB-DDA6A Rear panel.

AES/EBU Input

The XLR 3 pin socket has an impedance of 110Ω. It has the following connections:

- Pin 1: Screen
- Pin 2: Phase
- Pin 3: Non-phase

AES/EBU Outputs

The XLR 3 pin sockets have an impedance of 110Ω. They have the following connections:

- Pin 1: Screen
- Pin 2: Phase
- Pin 3: Non-phase

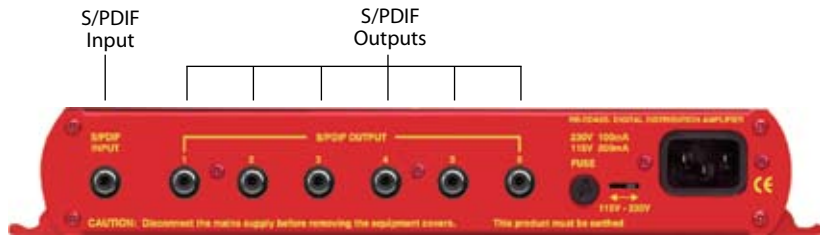

Fig 9-5: RB-DDA6S Rear Panel.

S/PDIF Input

The S/PDIF phono input has an impedance of 75Ω.

S/PDIF Outputs

The S/PDIF phono outputs have an impedance of 75Ω.

9 AUDIO DISTRIBUTION AMPLIFIERS



AUDIO DISTRIBUTION AMPLIFIERS-RB-DDA6A & RB-DDA6S

Technical Specifications

Audio Specifications

RB-DDA6A

Input Impedance:	110Ω ± 20% balanced
Output Impedance:	110Ω ± 20% balanced
Sample Freq Range:	30-100kHz (i.e. including 32kHz, 44.1kHz, 48kHz, 64kHz, 88.2kHz and 96kHz)
Signal Level:	3V/10V peak to peak min/max

RB-DDA6S

Input Impedance:	75Ω ±5% unbalanced
Output Impedance:	75Ω ±5% unbalanced
Sample Freq Range:	30-100kHz (i.e. including 32kHz, 44.1kHz, 48kHz, 64kHz, 88.2kHz and 96kHz)
Signal Level:	Balanced min 0.5V ±20% peak to peak

Connections

RB-DDA6A

Input:	1 x AES/EBU XLR 3 pin female (balanced)
Outputs:	6 x AES/EBU XLR 3 pin male (balanced)
Mains Input	Filtered IEC, 110-120V, or 220-240V switchable, fused, 6W max
Fuse Rating:	Anti-surge fuse 100mA 20 x 5mm (230VAC) Anti-surge fuse 250mA 20 x 5mm (115VAC)

RB-DDA6S

Input (unbalanced):	1 x S/PDIF RCA phono female
Outputs:	6 x S/PDIF RCA phono female (unbalanced)
Mains Input:	Filtered IEC, 110-120V, or 220-240V switchable, fused, 6W max
Fuse Rating:	Anti-surge fuse 100mA 20 x 5mm (230VAC) Anti-surge fuse 250mA 20 x 5mm (115VAC)

Equipment Type

RB-DDA6A	6 way AES/EBU stereo digital distribution amplifier
RB-DDA6S	6 way stereo S/PDIF digital distribution amplifier



Physical Specifications

RB-DDA6A

Dimensions (Raw):	28cm (W) x 10.8cm (D) x 4.2cm (H) (1U)
Dimensions (Boxed):	36cm (W) x 20.5cm (D) x 6cm (H)
Weight:	Nett: 0.95kg Gross: 1.4kg

RB-DDA6S

Dimensions (Raw):	28cm (W) x 10.8cm (D) x 4.2cm (H) (1U)
Dimensions (Boxed):	36cm (W) x 20.5cm (D) x 6cm (H)
Weight:	Nett: 0.9kg Gross: 1.35kg

10 RB-DDA6W 6 Way Word Clock Distribution Amplifier

Introduction



Fig 10-1: RB-DDA6W Front Panel.

The RB-DDA6W 6 Way Word Clock Distribution Amplifier distributes a word clock BNC input signal to 6 word clock BNC outputs re-conditioned. It is used in distributing reference clocks for digital audio systems.

It has a single female BNC input which is distributed to 6 female BNC outputs.

The unit's primary application is to distribute a master TTL word clock source to multiple pieces of equipment that need to be synchronised from the master.



10 AUDIO DISTRIBUTION AMPLIFIERS



AUDIO DISTRIBUTION AMPLIFIERS - RB-DDA6W

System Block Diagram

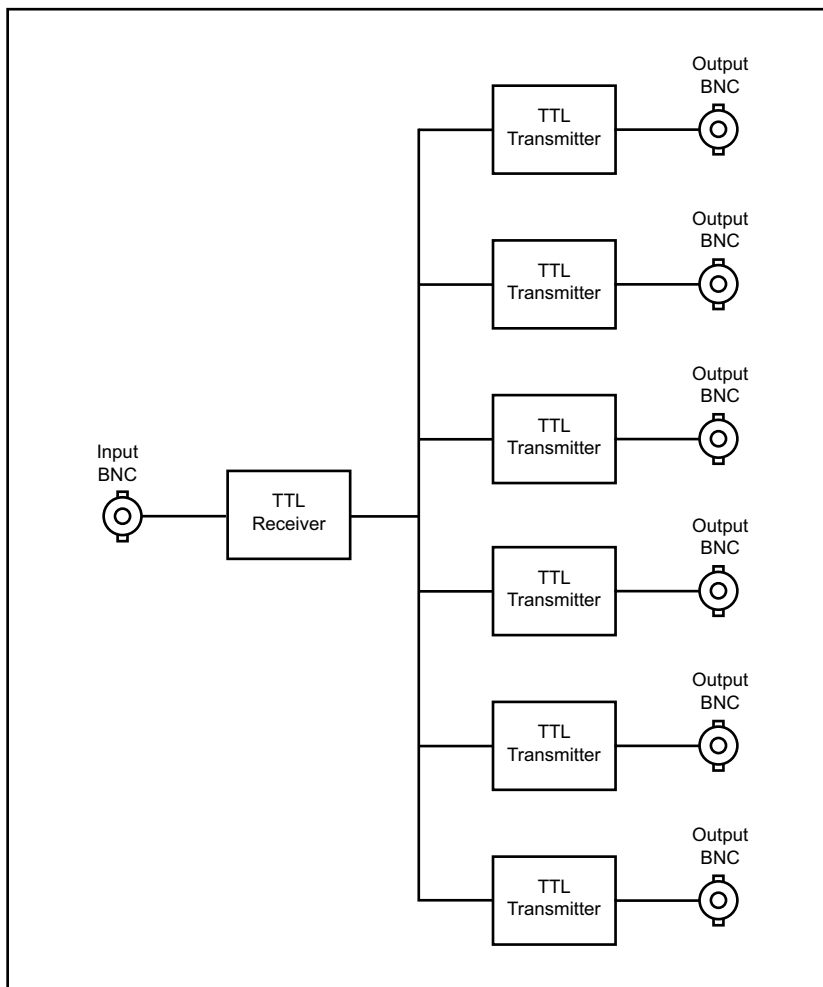

Fig 10-2: RB-DDA6W System Block Diagram.

Rear Panel Connections and Operations

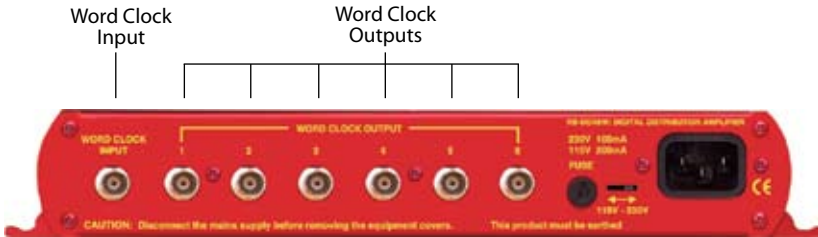



Fig 10-3: RB-DDA6W Rear Panel.

Word Clock Input

The Word Clock BNC input has an impedance of 75 Ω.

Word Clock Outputs

The Word Clock BNC outputs have an impedance of <50 Ω.

Technical Specifications	
Signal Specifications	
Input Impedance	75Ω
Output Impedance	<50Ω
Connections	
Input	1 x BNC female
Outputs	6 x BNC female
Mains Input	Filtered IEC, 110-120V, or 220-240V switchable, fused, 6W max
Fuse Rating:	Anti-surge fuse 100mA 20 x 5mm (230VAC) Anti-surge fuse 250mA 20 x 5mm (115VAC)
Equipment Type	
RB-DDA6W	6 way word clock distribution amplifier
	
Physical Specifications	
Dimensions (Raw)	28cm (W) x 10.8cm (D) x 4.2cm (H) (1U)
Dimensions (Boxed)	36cm (W) x 20.5cm (D) x 6cm (H)
Weight	Nett: 0.9kg Gross: 1.35kg



AUDIO DISTRIBUTION AMPLIFIERS - RB-DDA6W

11

HEADPHONE DISTRIBUTION AMPLIFIERS



11 RB-HD1 Stereo Headphone Amplifier & RB-HD2 Dual Headphone Amplifier

Introduction



Fig 11-1: RB-HD1 Front Panel.

The RB-HD1 is a 1U rack-mount stereo headphone amplifier for driving up to two pairs of professional stereo headphones from a single stereo or mono input. One headphone socket is on the front panel with one on the rear.

The main stereo input uses electronically balanced XLR-3 connectors on the rear panel, which can be wired un-balanced. The output volume for the headphones can be controlled either by a pot situated on the front panel or a VCA signal supplied externally via the remote connector.

A mono input can be mixed into the main headphone feed, for example, for mixing in talkback to the headphones. This has an input level control via a recessed adjustable potentiometer. The mono mix input can also be controlled remotely.

A stereo/mono switch is recessed on the rear panel to prevent accidental knocking. With mono selected, audio is sent to both left and right ear pieces. A LED power indicator on the front panel displays the power supply connection.



Fig 11-2: RB-HD2 Front Panel.

The RB-HD2 is a high performance 2-way stereo headphone distribution amplifier for driving up to 2 pairs of professional stereo headphones from a single stereo or mono input. A switch on the rear panel enables the distribution of a mono signal to all four outputs (i.e. both earpieces of a pair of stereo headphones) via the left channel input. The stereo/mono switch is located on the rear panel to prevent accidental knocking.

The XLR-3 inputs are electronically balanced and can be wired unbalanced. There are two pre-set controls on the rear panel that adjust the level of the master input signal to the outputs.

Each output is on a ¼" stereo jack socket and is designed to drive 150mW into 32 ohm to 600 ohm stereo headphones. The outputs are individually buffered with their own front panel volume control. A LED power indicator on the front panel displays the power supply connection.

System Block Diagrams

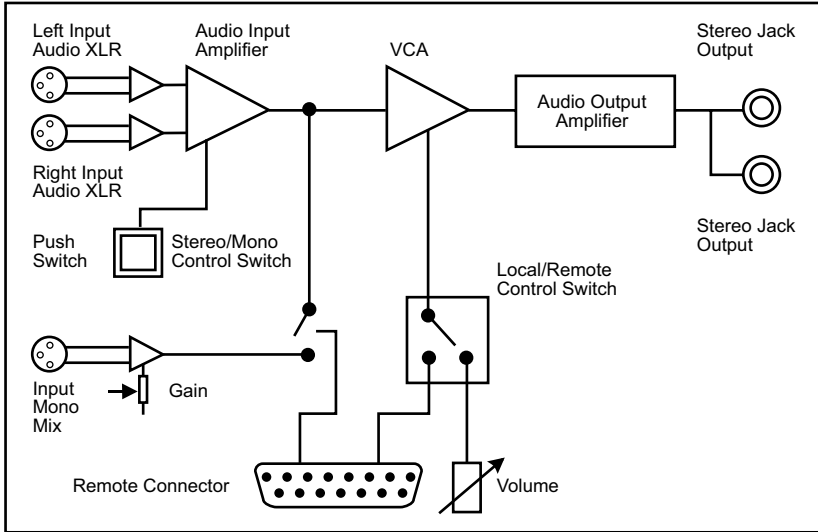

Fig 11-3: RB-HD1 Block Diagram.

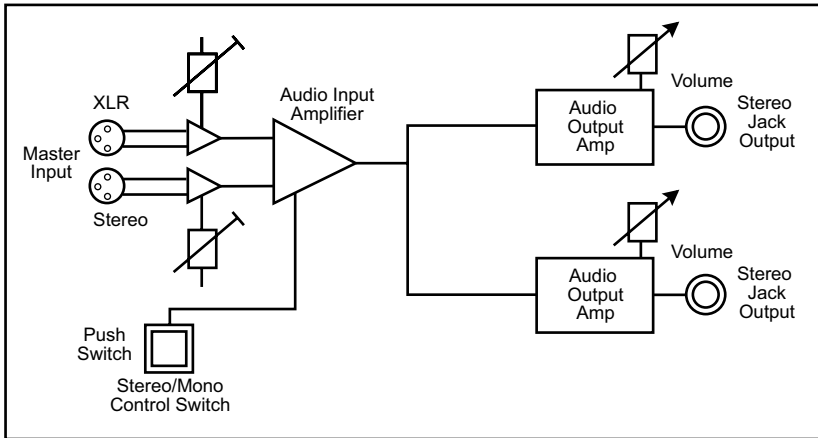

Fig 11-4: RB-HD2 Block Diagram.



HEADPHONE DISTRIBUTION AMPLIFIERS-RB-HD1 & RB-HD2

11 HEADPHONE DISTRIBUTION AMPLIFIERS



Front Panel Connections and Controls

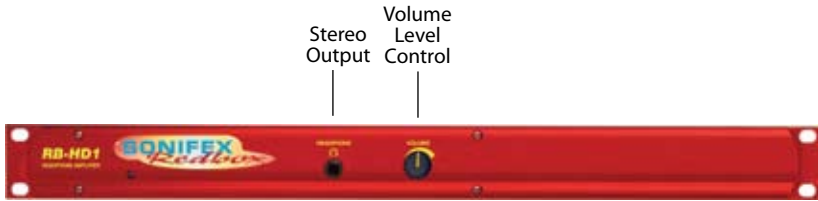

Fig 11-5: RB-HD1 Front Panel Controls.

Stereo Outputs 1-2 (Mono Outputs 1-2)

The outputs available on the front and rear panel through 1/4" stereo jack sockets are push-pull, designed to drive 150 mW into 32Ω to 600Ω professional headphones. Each output is individually buffered.

Volume Level Control

The volume level control sets the output level of the two stereo headphone sockets. The two headphone outputs have a maximum output of +11 dBu.

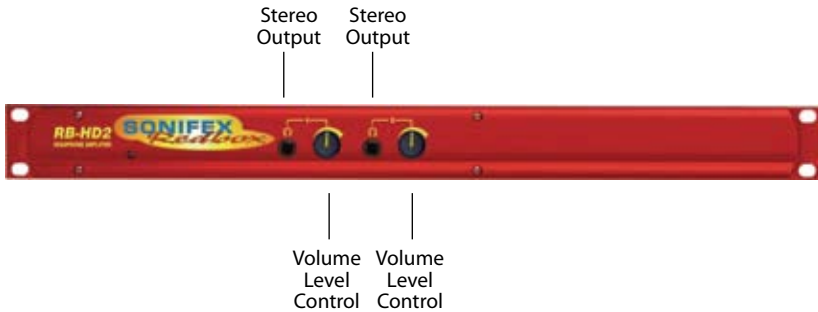

Fig 11-6: RB-HD2 Front Panel Controls.

Stereo Outputs 1-2 (Mono Outputs 1-2)

The outputs available on the front panel through 1/4" stereo jack sockets are push-pull, designed to drive 150 mW into 32Ω to 600Ω professional headphones. Each output is individually buffered.

Channel Volume Controls

Each channel has its own volume control so that you have control of the signal volume to an individual output from the master input.

Rear Panel Connections and Operation

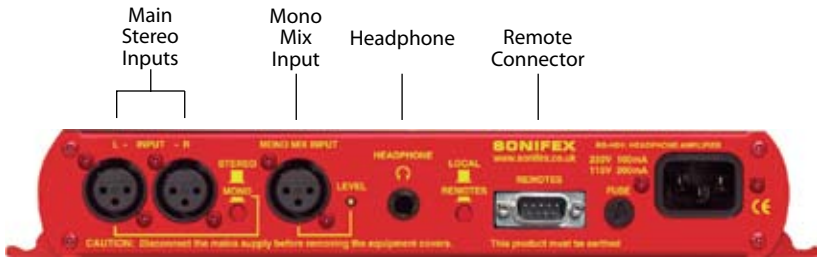

Stereo/ Mono Switch Mono Mix Input Gain Adjustment Local/ Remote Control Switch

Fig 11-7: RB-HD1 Rear Panel.

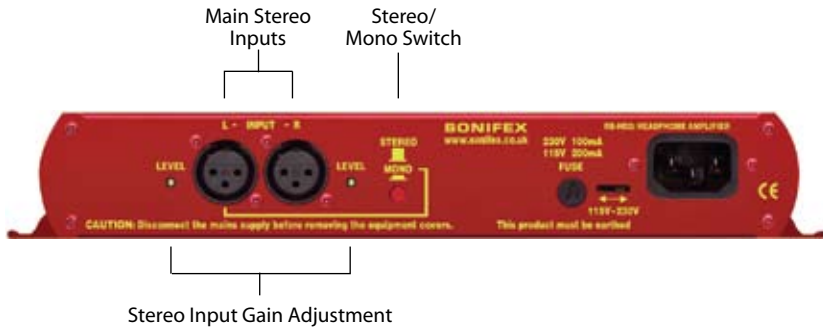

Stereo Input Gain Adjustment

Fig 11-8: RB-HD2 Rear Panel.

Main Stereo Inputs (Left and Right)

The XLR-3 input connectors can take balanced professional levels, or unbalanced by using the volume control to increase the input level, and by connecting the non-phase to the signal ground. The input can be configured as either a stereo input with two stereo outputs or a mono input with two mono paired outputs. The XLR 3 pin input has the following connections:

- Pin 1: Screen
- Pin 2: Phase
- Pin 3: Non-phase

Stereo Input Gain Adjustment (RB-HD1)

There are two preset controls on the rear panel that adjust the level of the master input signal to the outputs from -12dB to +20dB gain.



11 HEADPHONE DISTRIBUTION AMPLIFIERS



Stereo/Mono Operation

The mode of operation may be switched between a stereo distributed channel to 2 stereo channels, or a mono channel to two mono paired outputs (i.e. the same signal to both ear pieces) by using the push button, mounted on the rear panel to prevent accidental switching.

Mono Mix Input (RB-HD1)

The XLR-3 input connector can take balanced professional levels, or unbalanced by connecting the non-phase to the signal ground. This input is used for mixing with the main stereo input, which is controlled by the MIX_EN pin (pin 8 on the remote connector) on the remote connector. While this signal is shorted to the ground pin (pin 9 on the remote connector) mixing is enabled and is only disabled once the signal from MIX_EN to pin 9 is open on the remote connector. The XLR 3 pin input has the following connections:

Pin 1: Screen

Pin 2: Phase

Pin 3: Non-phase

Mono Mix Input Gain Adjustment (RB-HD1)

A rotary pre-set potentiometer can be used to adjust the gain of the mono mix input by 22dBu.

Local/Remote Control Operation (RB-HD1)

The level to the two outputs can be controlled in one of two ways, either locally, by the pot situated on the front panel or remotely, by a VCA signal supplied externally to the remote connector.

Remote Connector (RB-HD1)

The remote connector is a 9-pin D-type socket, which is situated on the rear panel. It has connections as shown below.

Pin No.	Signal	I/O	Description
Pin 1	Pot wiper	I	Volume control signal
Pin 2	Pot top	O	+5V
Pin 3	N/C	-	No connection
Pin 4	N/C	-	No connection
Pin 5	N/C	-	No connection
Pin 6	Pot bottom	-	Ground
Pin 7	N/C	-	No connection
Pin 8	MIX_EN	I	Make to pin 9
Pin 9	0V	-	Ground

Fig 11-9: RB-HD1 Remote Connector



Technical Specifications

Audio Specifications RB-HD1 & RB-HD2:

Maximum Input Level:	+28dBu
Input Impedance:	>20kΩ balanced bridging (main)
Input Gain Range:	-12dB to +20dB (pre-set pots) (RB-HD2)
Output Level:	Drives 150 mW into 32Ω to 600Ω headphones
Volume Control:	-80dB to +11dB gain
Mono Mix Input Gain Range:	22dBu (RB-HD1)

Connections

RB-HD1:

Main Stereo Input:	2 x XLR 3 pin female (Balanced, can be wired unbalanced)
Mono Mix Input:	1 x XLR 3 pin female (Balanced, can be wired unbalanced)
Outputs:	2 x ¼" (6.35mm) A/B gauge 3-pole stereo jack sockets
Remote Control:	9-pin D-type socket
Mains Input:	Filtered IEC, 110V-120V, or 220-240V switchable, fused, 9W maximum
Fuse Rating:	Anti-surge fuse 100mA 20 x 5mm (230VAC) Anti-surge fuse 250mA 20 x 5mm (115VAC)

RB-HD2:

Main Stereo Input	2 x XLR 3 pin female (Balanced, can be wired unbalanced)
Outputs	2 x ¼" (6.35mm) A/B gauge 3-pole stereo jack sockets
Mains Input	Filtered IEC, 110V-120V, or 220-240V, fused, switchable, 9W maximum
Fuse Rating:	Anti-surge fuse 100mA 20 x 5mm (230VAC) Anti-surge fuse 250mA 20 x 5mm (115VAC)

Equipment Type

RB-HD1:	Stereo headphone amplifier
RB-HD2:	Dual stereo headphone amplifier



Physical Specifications

RB-HD1:

Dimensions (Raw):	48cm (W) x 10.8cm (D) x 4.2cm (H) (1U)
Dimensions (Boxed):	53cm (W) x 20.5cm (D) x 6cm
Weight:	Nett: 1.35kg Gross: 2.0kg

RB-HD2:

Dimensions (Raw):	48cm (W) x 10.8cm (D) x 4.2cm (H) (1U)
Dimensions (Boxed):	53cm (W) x 20.5cm (D) x 6cm
Weight:	Nett: 1.35kg Gross: 2.0kg

12 HEADPHONE DISTRIBUTION AMPLIFIERS



12 RB-HD6 6 Way Headphone Distribution Amplifier

Introduction



Fig 12-1: RB-HD6 Front Panel.

The RB-HD6 is a high performance 6-way stereo headphone distribution amplifier for driving up to 6 pairs of professional stereo headphones from a single stereo or mono input. A switch on the rear panel enables the distribution of a mono signal to all twelve outputs (i.e. both earpieces of a pair of stereo headphones) via the left channel input.

Alternatively, the RB-HD6 can be used as six separate stereo headphone amplifiers by using the override (insert-point, or break-jack) input associated with each outlet. A typical application might be to provide common headphone feeds for guests around a table in a radio studio, with a separately derived feed, perhaps including talkback, for the presenter. The over-ride inputs can also be configured as parallel outputs (to the front outputs) by altering jumper settings inside the unit.

The XLR-3 inputs are electronically balanced and can be wired unbalanced. There is a master control that adjusts the level of the master signal to all the outputs. This master control can be disabled by the use of internal jumpers. Each output is designed to drive 150 mW into 32 Ω to 600 Ω stereo headphones and is individually buffered with its own volume control.

The input level and output volume controls are all potentiometers on the front panel. The stereo/mono switch is recessed on the rear panel to prevent accidental knocking. A LED power indicator on the front panel displays the power supply connection.

System Block Diagram

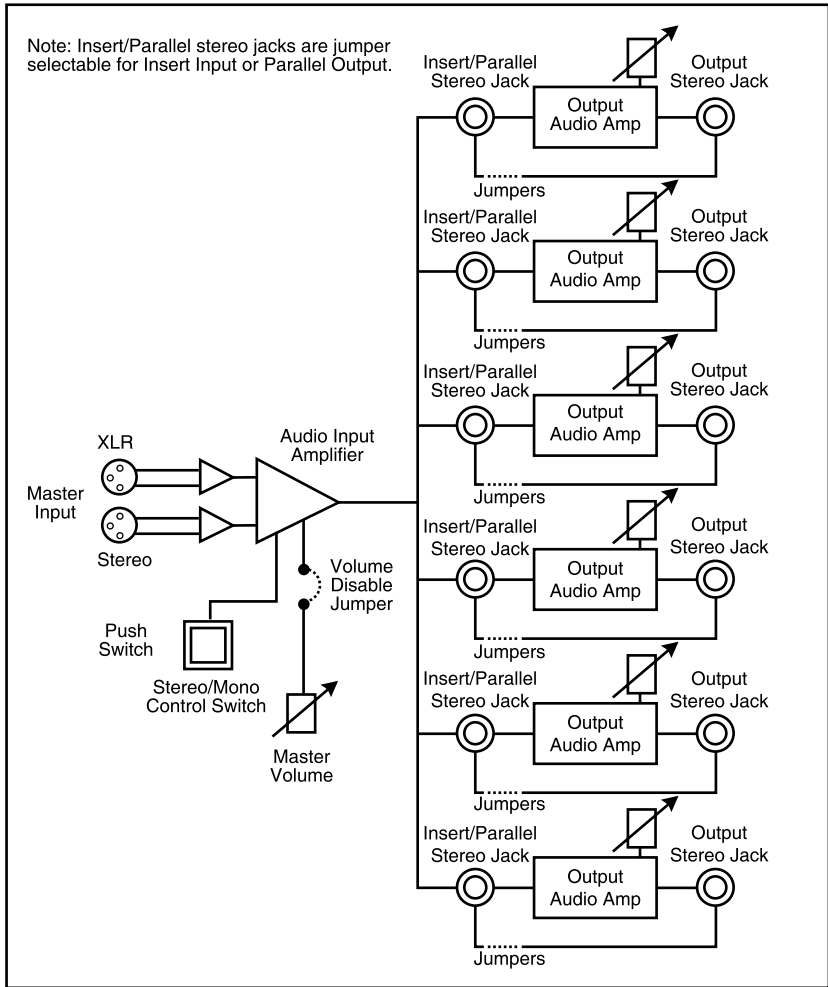

Fig 12-2: RB-HD6 Block Diagram.



HEADPHONE DISTRIBUTION AMPLIFIERS - RB-HD6

12 HEADPHONE DISTRIBUTION AMPLIFIERS



Rear Panel Connections and Operation

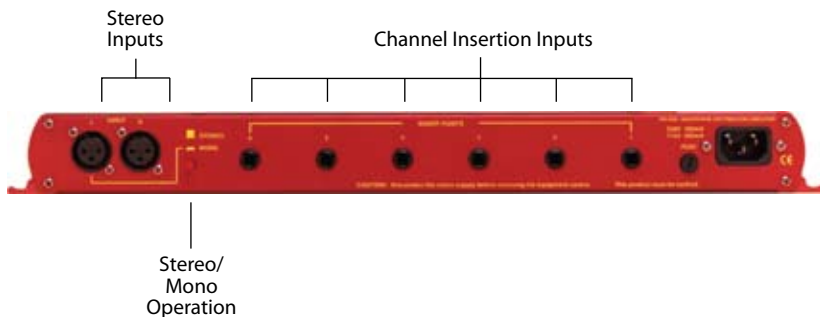

Fig 12-3: RB-HD6 Rear Panel.

Stereo Input (Left and Right)

The XLR-3 input connectors can take balanced professional levels, or unbalanced by using the front panel master control to increase the input level, and by connecting the non-phase to the signal ground. The input can be configured as either a stereo input with six stereo outputs or a mono input with six mono paired outputs. The XLR 3 pin input has the following connections:

- Pin 1: Screen
- Pin 2: Phase
- Pin 3: Non-phase

Stereo/Mono Operation

The mode of operation may be switched between a stereo distributed channel to 6 stereo channels, or a mono channel to six mono paired outputs (i.e. the same signal to both ear pieces), by the push button on the rear panel which is recessed to prevent accidental switching.

Channel Insertion Inputs/Parallel Outputs

Each channel has an unbalanced override/insertion input via a 1/4" stereo audio jack socket on the rear panel, which overrides the master input.

Each connector can also be individually configured as a parallel output providing the same signal as the output on the front of the unit. To configure the jack connector as an output, you'll need to alter some jumper settings inside the unit.

Removing the Equipment Covers

To get inside the RB-HD6, first ensure that it has been disconnected from the mains power and that the mains IEC lead to the unit has been removed. Observing anti-static precautions, undo the four cross-head screws on the back panel at the far left and far right of the panel (2 at each end). Also undo the small brass screws which hold the top and bottom panels to the rear panel. The rear panel should slide backwards out of the unit together with the main circuit board.

Configuring Insert Inputs/Parallel Outputs

On the main circuit board, you'll see some jumpers (small black rectangles), the position of which will define whether a particular jack socket operates as an input or output. The drawings below show the different jumper settings available. Each input/output can be configured individually, so you could have three jacks set as inputs and three as outputs if needed.

Input/Output		1	2	3	4	5	6
Jumpers to Alter	Left	JP1 & 2	JP5 & 6	JP9 & 10	JP13 & 14	JP17 & 18	JP21 & 22
	Right	JP3 & 4	JP7 & 8	JP11 & 12	JP15 & 16	JP19 & 20	JP23 & 24

Fig 12-4: RB-HD6 Jumper Assignments.

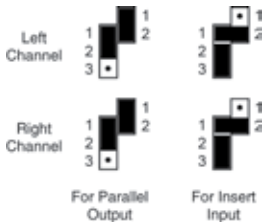

Fig 12-5: RB-HD6 Jumper Positions.

Once you've set up the jumpers, slide the circuit board back into the Redbox housing using the slots along the inside edge of the metalwork as a guide. Replace the screws on the top, bottom and rear panels of the RB-HD6.

Important Note: The screws provide earthing protection to the chassis and grounding protection for CE approval – it is important that you reinsert all the screws provided.

Front Panel Connections and Controls

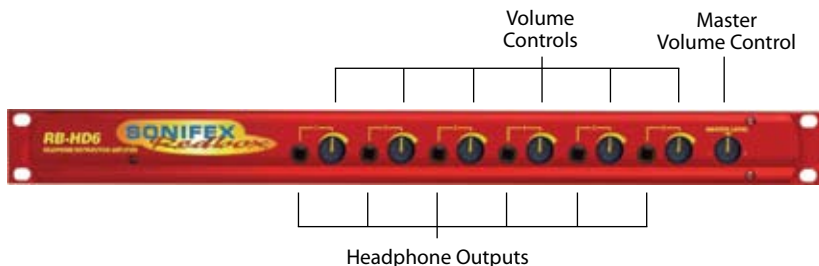

Fig 12-6: RB-HD6 Front Panel Controls.

Stereo Outputs 1-6 (Mono Outputs 1-6)

The outputs available on the front panel through ¼" stereo jack sockets are push-pull, designed to drive 150 mW into 32Ω to 600Ω professional headphones. Each output is individually buffered.



12 HEADPHONE DISTRIBUTION AMPLIFIERS



Master Level Control

The master level control will set the maximum level of all channels and will need to be set high if an unbalanced consumer input level (-10dbu) is used. This level control can be disabled by setting jumpers within the unit. See Page 46 for details on removing the equipment covers. The two jumpers JP25 and JP26 can be found near the volume potentiometer VR1 :

Jumper	JP25	JP26
Enable Master Level Control	On	On
Disable Master Level Control	Off	Off

Fig 12-7: RB-HD6 Master Level Control.

Channel Volume Controls

Each channel has its own volume control so that you have control of the signal volume to an individual output whether it is from the master input or the override input.

Technical Specifications

Audio Specifications

Input Impedance:	>20k Ω balanced bridging (main), >10k Ω unbalanced (insert points)
Maximum Input Level:	+28dBu
Output Level:	Drives 150 mW into 32 Ω to 600 Ω headphones
Override Inputs:	+3dBu for full volume at +18dB gain
Individual Volume Control:	-60dB to +18dB gain
Master Volume Control:	\pm 10dB gain

Connections

Main Stereo Inputs:	2 x XLR 3 pin female (Balanced, can be wired unbalanced)
Insert Inputs & Parallel Outputs:	6 x 1/4" (6.35mm) A-gauge 3-pole stereo jack sockets (unbalanced, jumper configured)
Outputs:	6 x 1/4" (6.35mm) A-gauge 3-pole stereo jack sockets
Mains Input:	Filtered IEC, 110V-120V, or 220-240V switchable, fused, 9W maximum
Fuse Rating:	Anti-surge fuse 100mA 20 x 5mm (230VAC) Anti-surge fuse 250mA 20 x 5mm (115VAC)

Equipment Type

RB-HD6: 6 way stereo headphone distribution amplifier



Physical Specifications

Dimensions (Raw):	48cm (W) x 10.8cm (D) x 4.2cm (H) (1U)
Dimensions (Boxed):	53cm (W) x 20.5cm (D) x 6cm (H)
Weight:	Nett: 1.35kg Gross: 2.0kg

13 RB-DHD6 Digital 6 Way Headphone Distribution Amplifier

Introduction



Fig 13-1: RB-DHD6 Front Panel.

**24 BIT
96 kHz**

The RB-DHD6 digital 6 way headphone distribution amplifier is a 1U rack-mount which receives a digital input signal, as either AES/EBU or S/PDIF and converts it to 6 individually buffered, jack-plug, headphone outputs, each with their own volume control.

Useful for connection to digital mixing desks, digital routers and matrices, the RB-DHD6 connects directly to an AES/EBU or S/PDIF output to provide the highest quality audio directly to the headphones. The input connectors consist of a single balanced XLR-3 for the AES/EBU input and a single unbalanced phono connector for the S/PDIF input.

A button located on the rear panel is used to select either the AES/EBU, or S/PDIF, input and de-emphasis on the output can be controlled via dipswitch. If de-emphasis is selected, the RB-DHD6 will decode 50/15µs emphasis when indicated by certain channel status bits in the incoming digital audio data.

When operating, the front panel power LED flashes red and amber whenever the unit is not synchronised to the incoming digital signal.

System Block Diagram

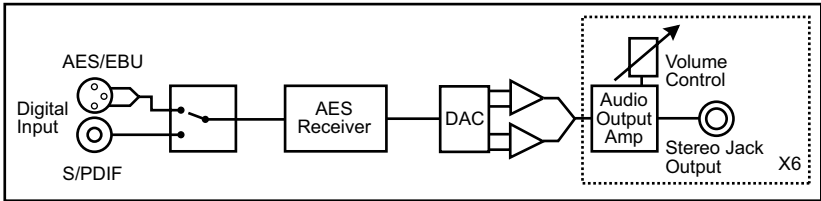

Fig 13-2: RB-DHD6 System Block Diagram.

Front Panel Indicators & Controls

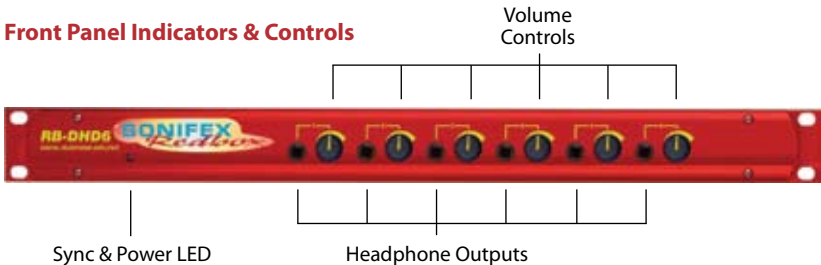

Fig 13-3: RB-DHD6 Front Panel Controls.



AUDIO DISTRIBUTION AMPLIFIERS - RB-DHD6

13 AUDIO DISTRIBUTION AMPLIFIERS



Sync & Power Indicator

The LED on the front panel is normally red to indicate that power is present on the unit. However, it also has a secondary role to indicate the status of the digital inputs

Flashing between red and amber – indicates a loss of a valid digital input signal.

Headphone Outputs

The headphone outputs on the front panel consist of six ¼" stereo jack sockets, designed to drive 150 mW into 32Ω to 600Ω professional headphones.

Volume Control

The headphone outputs each have their own volume control and have a maximum output level of +12dBu.

Rear Panel Connections and Operation

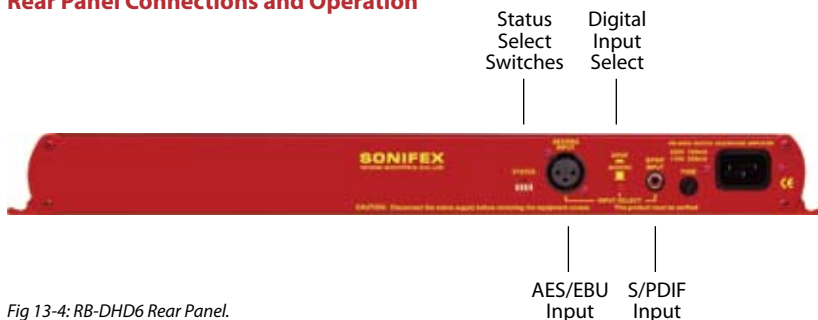

Fig 13-4: RB-DHD6 Rear Panel.

AES/EBU Input

The digital input XLR 3 pin socket has an impedance of 110Ω. It has the following connections:

- Pin 1: Screen
- Pin 2: Phase
- Pin 3: Non-phase

The signals on this connector should meet the IEC 60968 specification

S/PDIF Input

The S/PDIF digital phono input has an impedance of 75Ω.

Status Select Switches

Status		
1	On	De-emphasis On
1	Off	De-emphasis Off
2		Reserved
3		Reserved
4		Reserved

Fig 13-5: RB-DHD6 Status Select Switches.

If de-emphasis is 'on' (switch 1) the RB-DHD6 will decode 50/15µs emphasis when indicated by certain channel status bits in the incoming digital audio data. When 'off', no de-emphasis is applied. The switch is 'on' when it is down.

Digital Input Select Button

This button is used to switch the digital input between the AES/EBU XLR connector (button out) and the S/PDIF phono connector (button in).



Technical Specifications

Audio Specification

Input Impedance:	110Ω ± 20% AES/EBU 75Ω ± 5% S/PDIF
Sample Freq. Range:	30kHz – 100kHz
Dynamic Range:	>100dB
Headphones:	Drives 150 mW into 32Ω to 600Ω headphones
Max Output Level:	+12dBu
Headphone Gain Range:	-80dBu to +12dBu

Connections

Digital Inputs:	1 x AES/EBU XLR 3 pin female 1 x S/PDIF RCA phono
Headphone Outputs:	6 x ¼" (6.35mm) A/B gauge 3-pole stereo jack sockets
Mains Input:	Filtered IEC, 110-120V, or 220-240V switchable, fused 10W max
Fuse Rating:	Anti-surge fuse 100mA 20 x 5mm (230VAC) Anti-surge fuse 250mA 20 x 5mm (115VAC)

Operational Controls

Digital Input Select:	AES/EBU or S/PDIF, via push-switch
De-emphasis:	DIP switch

Equipment Type

RB-DHD6	Digital 6 way stereo headphone distribution amplifier
---------	---



Physical Specifications

Dimensions (Raw)	48cm (W) x 10.8cm (D) x 4.2cm (H) (1U)	
Dimensions (Boxed)	53cm (W) x 20.5cm (D) x 6cm (H)	
Weight	Nett: 1.6kg	Gross: 2.2kg

14 CONNECTORS & CABLING



CONNECTORS & CABLING

14 Connectors & Cabling

Many of the problems associated with installing and maintaining studio equipment are due to the use of poor cables or faulty connections. It is recommended that, wherever possible, pre-wired cables are purchased from recommended manufacturers. If you need bespoke cables making, please ensure that a qualified engineer carries out the work.

The main types of connectors used with the Redboxes are the following:

XLR 3 Pin Connectors

The following diagram shows the pin details for the 3 pin XLR sockets and plugs:

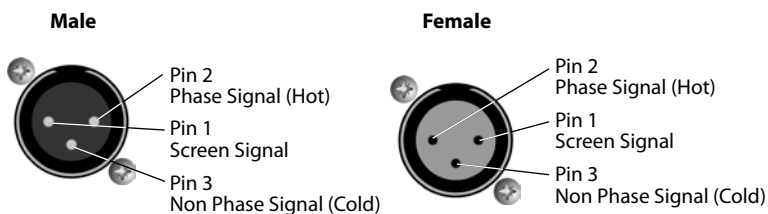

Fig 14-1: XLR Connectors.

RCA Phono Connectors

The following diagram shows the connection details for the RCA phono connectors:

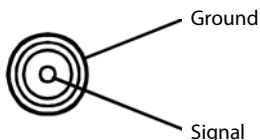

Fig 14-2: RCA Phono Connector.

1/4" Jack Connector

The following diagram shows the connection details for the jack connector:

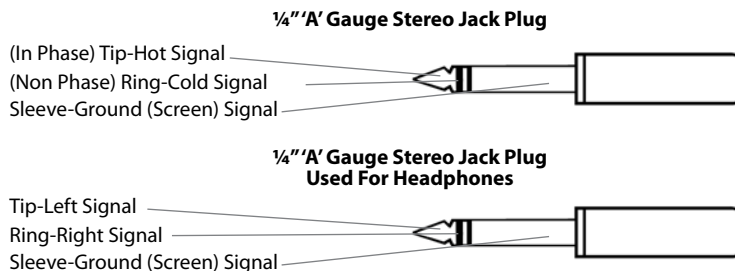

Fig 14-3: 1/4" Jack Connector.

D-Type Connectors

The following diagram shows the connection details for the D-type connectors as viewed from the rear of a Redbox :

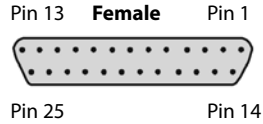
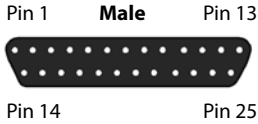

Fig 14-4: 25 Way D-Type Connectors.

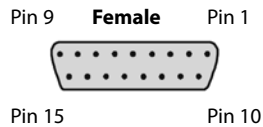
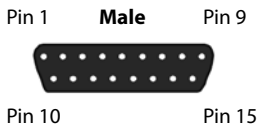

Fig 14-5: 15 Way D-Type Connectors.

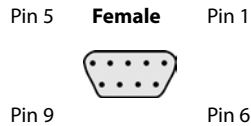

Fig 14-6: 9 Way D-Type Connectors.



15 GLOSSARY



GLOSSARY

15 Glossary

1kHz	1000Hz or 1 kilohertz tone of 1kHz is often used for line-up and testing.
ADSL	Asynchronous Digital Subscriber Link - a broadband delivery system over standard telephone lines (between the exchange and the user).
AES	Audio Engineering Society.
AES/EBU	Professional digital audio standard covering frame format, connections and interfaces. Interface is usually on XLR sockets and plugs.
AM	Amplitude Modulation - older analogue modulation standard used on long, medium and short wave.
APT-X	Data reduction process for reducing the amount of storage or bit-rate need for audio.
ATRAC	Adaptive Transform Acoustic Coding - the data reduction of compression scheme used in Mini-disk machines.
Attenuation	The reduction of a signal level. Attenuation is usually measured in dB.
B-Channel	Bearer Channel - the main carrier channels used in ISDN.
Balance	The relative levels of the left and right channels of a stereo signal.
Balanced Audio	A way of sending audio over cable that protects it from induced interference.
CAR	See racks room.
CAT 5	Category 5 - type of cabling/connectivity standards used in computer networking.
CD	Compact Disc.
Cleanfeed	A cleanfeed is a signal produced by a telco module on a mixer which is used as the output to be fed back to a caller on a telephone line. The cleanfeed is a sum of all the other signals which constitute the programme output, except for the caller's audio. A cleanfeed signal will generally be of a better quality than a mix-minus signal.
Clipping	The onset of severe distortion in the signal path, usually caused by the peak signal voltage being limited.
CMRR	Common Mode Rejection Ratio. This is the ratio of the extent to which a differential amplifier will cancel noise, which is present on both inputs, compared to its ability to amplify the signal.
CODEC	COder-DECoder - used to change a signal from one format to another and back again.
Codecs	Using digital circuits being offered by telecom providers, usually ISDN (Integrated Services Data Networks) or other data transfer methods, audio can be transferred with good to excellent quality over what almost amount to dial-up telephone lines. The units operate by Coding the audio into a digital data stream that can be transferred over the digital circuit which is Decoded at the receiving end (Thus CoDec). By using single or multiple circuits, very high quality audio can be transferred from one place to another, even internationally.
Cross-talk	This is the amount of a signal from a bus which appears, or is induced, on a different signal. The problem is usually most prevalent with adjacent channels.
DA	Distribution Amplifier.
DAB	Digital Audio Broadcasting = now called Digital Radio.

DAT	Digital Audio Tape.
dB (decibel)	A ratio of two voltages or signal levels, expressed by the equation $dB=20\text{LOG}(V1/V2)$ Adding the suffix "u" denotes that the signal is relative to 0.775V RMS. Adding the suffix "v" denotes that the signal is relative to 1V RMS.
DCF	This is radio code signal sourced from Mainflingen, near Frankfurt in Germany, which can be used to automatically synchronize the Sentinel+ audio logger and PC time to an accurate atomic clock, European Time.
DDS & DDS-2	DDS and DDS-2 are world-wide standards established by Sony and Hewlett-Packard which introduce many levels of error checking as data is written to a DAT tape. DDS(-2) drives and tapes are used in security products all over the world. 120m DDS-2 DAT tapes are more accurate and reliable than DDS tapes and are able to store twice as much audio data.
DI	Direct Inject - a means of driving audio, usually from an instrument such as a guitar, to allow the audio signal to be fed directly into a sound desk input.
DLS	Dynamic Label segment - a text message scheme used in digital radio, usually to carry information about the programme. Like the radio-text scheme used in RDS.
DSP	Digital Signal Processing.
EBU	European Broadcasting Union.
EIN	Equivalent input noise. It is the ratio of output noise to the gain. It describes the level of noise which would need to be fed into an ideal amplifier to produce the measured output noise.
ENG	(Electronic news gathering). Machines that can record audio and video information digitally.
EON	(RDS) Enhance Other Networks - a scheme for switching a listener's radio to another Effective Radiated Power.
EQ	(Equalisation). This is a method of cutting or boosting selected bands of frequencies in a signal.
FM	Frequency Modulation - a way of sending audio or data over a radio carrier, the 88 - 108 Broadcast Band is often known as the FM Band.
FSD	Full Scale Digits - This is the analogue representation of the maximum digital value that the converter in question can see before digital clipping occurs.
3G	Third generation mobile telephone system that may allow broadband transmission of Global Positioning System.
Gain	The degree of amplification, or attenuation, applied to a signal.
GRAM	Gramophone Reproducer - a turntable with a 'pick-up' amplifier and remote start interface.
HDLC	High Speed Data Link.
Hybrid	See TBU
IEC	International Electrotechnical Commission - often used to refer to a mains connectivity standard, i.e. A type of plug/socket similar to that of a kettle, used on most pro-audio equipment.
ISDN	Integrated Services Digital Network - a system for sending high bandwidth material over standard telephone lines.



GLOSSARY



GLOSSARY

kbps	Kilo-bits per second - the number of 1s or 0s transmitted or transferred in one second.
kHz	Kilo Hertz (samples per second).
LAN	Local Area Network - scheme where several computers on the same premises are connected together so that they can exchange data.
LCD	Liquid Crystal Display (grey displays e.g. on calculators).
LED	Light Emitting Diode (small lights e.g. on computers).
LNB	Low Noise Block - the RF amplifier attached to a satellite dish.
MCR	See racks room.
MDU	Mains Distribution Unit - a panel of mains outlets for power distribution.
MF	Medium Frequency - another name for Medium Wave - roughly frequencies between 300kHz and 3MHz.
MHz	Mega-hertz - One million cycles per second.
Mix-minus	A mix-minus is similar to a cleanfeed except that the caller's voice is removed from the signal electronically. Due to phasing problems at the signal band edges, the mix-minus method often produces a lower grade signal.
Mono	Monophonic sound (system of broadcasting, recording or reproducing sound) using only one channel between source and loudspeaker.
MP3	MPEG 1 Layer 3 - see MPEG.
MPEG	(ISO MPEG) Motion Picture Experts Group. For audio, this is used to refer to a framing format standard. There are several layers and variants. Most common ones are listed below. MPEG 1 Layer 1 Used for Digital Compact Cassette. MPEG 1 Layer 2 (Musicam) used in digital radio, digital terrestrial television, ISDN and many hard-disk storage systems. MPEG 1 Layer 3 Known as MP3. A more elaborate version of MPEG 1 Layer 2 that allows for audio storage using low bit-rates.
MSF	This is radio code signal sourced from Rugby in England, which can be used to automatically synchronize the Sentinel+ audio logger and PC time to an accurate atomic clock, UK Time.
Musicam	Masking Pattern Universal Sub-Band Encoding.
MUX	Short for Multiplex - a 'package' of digital radio services.
Pan	This controls the levels sent to the left and right outputs and is an abbreviation of 'panorama'.
PFL	(Pre Fade Listen, or Cue). This is a method of auditioning audio material independently of the programme output, without routing the signal to air. The PFL button on each channel routes the signal to the PFL bus, where it can be monitored.
PI Code	(RDS) Programme Information Code used to identify an FM RDS station.
PPM	Peak Performance Meter (BBC Specification).
Promo	Something used to promote a product.
PS Name (RDS)	Programme Service Name - 8 characters used for naming an FM RDS station.
PSU	Power Supply Unit.
PTY	(RDS and DAB) Programme Type. A code transmitted to describe the overall programme content of a radio station (Static PTY) and/or the moment by moment content (Dynamic PTY). RDS has 32 codes although 3 are used in special circumstances only.



Racks Room	Often called the Master Control Room (MCR) or Central Apparatus Room (CAR), the racks room is an engineering area containing studio routing to transmitter equipment. Outside sources, phone-in equipment, off-air and transmitter status monitoring and logging equipment (or the transmitter itself!) are stored here with limited access.
RDS	Radio Data System.
Reverb	An echo (in very basic terms).
RF	Radio Frequency.
RJ-45	A connection standard used in computer networking.
S/PDIF	Sony/Phillips Digital Interface. Domestic digital audio interface standard using phono connectors or optically using fibre-optic connectors.
SPL	Sound Pressure Level.
TA	Traffic Announcement (flag) - a means of signalling to a radio with FM RDS indicating that traffic/travel news is being broadcast.
T/B	Talk-back (and reverse talk-back). This is the ability for two or more studios to communicate with each other off-air.
TBU	See Telephone Balance Unit
TCP/IP	Transmission Control Protocol / Internet Protocol. Computer interconnection methodology used on the internet and LANs.
Telephone Balance Unit (TBU) or Hybrid	Telephone hybrids provide the interface between professional audio equipment and the public telephone network. They provide protection for your equipment and the public telephone lines, allowing for varying line signals and line conditions. Automatically cancelling out the unwanted signal they also facilitate two-way communication down a single telephone line. In most European countries, including the UK, the TBU must be approved for connection to telephone company lines. Sonifex TBUs carry British Telecom and pan European approval.
THD	The Total Harmonic Distortion is the percentage presence of signals outside the measured reference frequency.
TMC	(RDS) Traffic Message Channel.
TP	Traffic Programme (flag) - a means of indicating to an RDS radio that a station will carry traffic announcements.
U	A height measurement for rack-mount equipment: 1U = 1.75 inches 2U = 3.5 inches 3U = 5.25 inches 4U = 7 inches
UPS	Uninterruptible Power Supply. A device which maintains power to equipment when the electricity supply fails.
VHF	Very High Frequency - frequencies between 30MHz and 300MHz.
VP	Vertical Polarisation i.e. of FM radio transmission.
VSWR	Voltage Standing Wave Ratio
VU	Voltage units
WAP	Wireless Application Protocol - a system for delivering mini-web pages to mobile phones from the Internet.
X21	A data communications protocol used in synchronous connections.
XLR	Professional, robust lockable audio connector - sometimes known as a 'Canon' after one of the earlier manufacturers.

SONIFEX

www.sonifex.co.uk

t:+44 (0)1933 650 700

f:+44 (0)1933 650 726

sales@sonifex.co.uk

