

General Description

The Rane HC 6 is one of the most indispensable products in today's audio industry. Featuring six stereo headphone amplifiers, the HC 6 performs a number of necessary tasks, not all of which are headphone related.

The HC 6 provides Master stereo Inputs which can be used to drive any or all of the 6 stereo headphone amplifiers. A Mono switch is provided on the front panel to drive both channels of all 6 amplifiers from a common mono source. Six individual unbalanced stereo Inputs are available to drive any individual amplifier from a separate stereo source. These Inputs can be converted to mono balanced Inputs through internal jumpers if required. Outputs for all six channels are provided on the front panel and on the rear panel so that

headphones may be connected on either side based on the requirements of a given installation. Two pairs of headphones may be driven from each channel, one pair connected to the front and one to the rear.

The HC 6 is capable of delivering up to 450 milliwatts into headphones with rated impedances between 32-600 ohms. The precise amount of power depends on the exact impedance of the headphone in use and the number of headphones connected to the unit. Under most conditions, the HC 6 produces sound pressure levels in excess of 120 dB. This level is above the threshold of pain and is suitable for most listeners.

See the RaneNote, "Understanding Headphone Power Requirements" for further information.

Features

- Six Stereo Headphone Amplifiers
- Master Balanced/Unbalanced Stereo Inputs
- Six Unbalanced Stereo Inputs
- Six Output Level Controls
- Master Input Level Controls
- Stereo/Mono Switch
- Drives 32-600 ohm Headphones
- Front and Rear Output Jacks
- UL/CSA Remote Power Supply (120 VAC)
- CE (Low Voltage & EMC) Remote Power Supply (230 VAC)

Features and Specifications

Parameter	Specification	Limit	Units	Conditions/Comments
Power Output:	1 Ch. Driven			Max Avg (RMS) Power, 20-20 kHz
	450	5%	mW	32 ohm Headphones
	390	5%	mW	50 ohm Headphones
	285	5%	mW	100 ohm Headphones
	150	5%	mW	200 ohm Headphones
	100	5%	mW	300 ohm Headphones
	80	5%	mW	600 ohm Headphones
	6 Ch's Driven			
	240	5%	mW	32 ohm Headphones
	250	5%	mW	50 ohm Headphones
	180	5%	mW	100 ohm Headphones
	130	5%	mW	200 ohm Headphones
	100	5%	mW	300 ohm Headphones
	75	5%	mW	600 ohm Headphones
	(Note: Above values produce loudness levels of 120 dB in most headphones)			
Headphone Impedance Range	32-600	10%	ohms	For Best Performance
Inputs: Type	Active Balanced/Unbalanced			
.....Connectors	¼" TRS			
.....Impedance	20k	1%	ohms	
.....Maximum Level	+20	1	dBu	
Outputs: Type	(6) Stereo Amplifiers			(6) Outs Front + (6) Outs Rear
.....Connectors	¼" Tip = Left, Ring = Right			
.....Impedance	7.5	5%	ohms	Headphone Outputs
Overall Gain Range	Off to +28	1	dB	
LED Threshold: Signal Present	-20	1	dBu	Input Level
Ultrasonic Filter	20 kHz, 6 dB/Oct	5%	Hz	Linear Phase
Frequency Response	20-20 kHz	+0/-3	dB	
THD+Noise	0.005	.002	%	150 mW/200 ohms, 1 kHz, 1 Ch
	0.1	.02	%	150 mW/200 ohms, 20-20 kHz, 1 Ch
IM Distortion (SMPTE)	0.05	.01	%	60 Hz/7 kHz, 4:1, 150 mW/200 ohms
Signal-to-Noise Ratio	-94(main)/-104(channel)	2	dB	re 150 mW/200 ohms, 20 kHz BW
Mean Time Between Failure	20,500		Hrs	Mil Hdbk-217D, Section V
Unit: Agency Listing				
.....120 VAC model	Class 2 Equipment UL 813 Exempt CSA Exempt			National Electrical Code Class 2 Class 2
.....230 VAC model	VDE, SELV CE-EMC CE-Safety Exempt			Safety Extra-Low Voltage EMC Directive 89/336/EEC Per Article 1 of LV directive 73/23/EEC
Power Supply: Agency Listing				
.....120 VAC model	UL Listed CSA Certified			File no. E88261 File no. LR58948
.....230 VAC model	CE-EMC CE-Safety			EMC Directive 89/336/EEC LV directive 73/23/EEC
.....Requirement	18 VAC with Center Tap	10%	Vrms	Rane RS 1 Supplied
.....Maximum Current	750		mA	RMS Current From Remote Supply
Unit: Construction	All Steel			
.....Size	1.75"H x 19"W x 5.3"D (1U)			(4.4 cm x 48.3 cm x 21.6 cm)
.....Weight	6 lb			(2.7 kg)
Shipping: Size	4.25" x 20.3" x 13.75"			(11 cm x 52 cm x 35 cm)
.....Weight	12 lb			(5.4 kg)
Note: 0 dBu = 0.775 Vrms				

Block Diagram

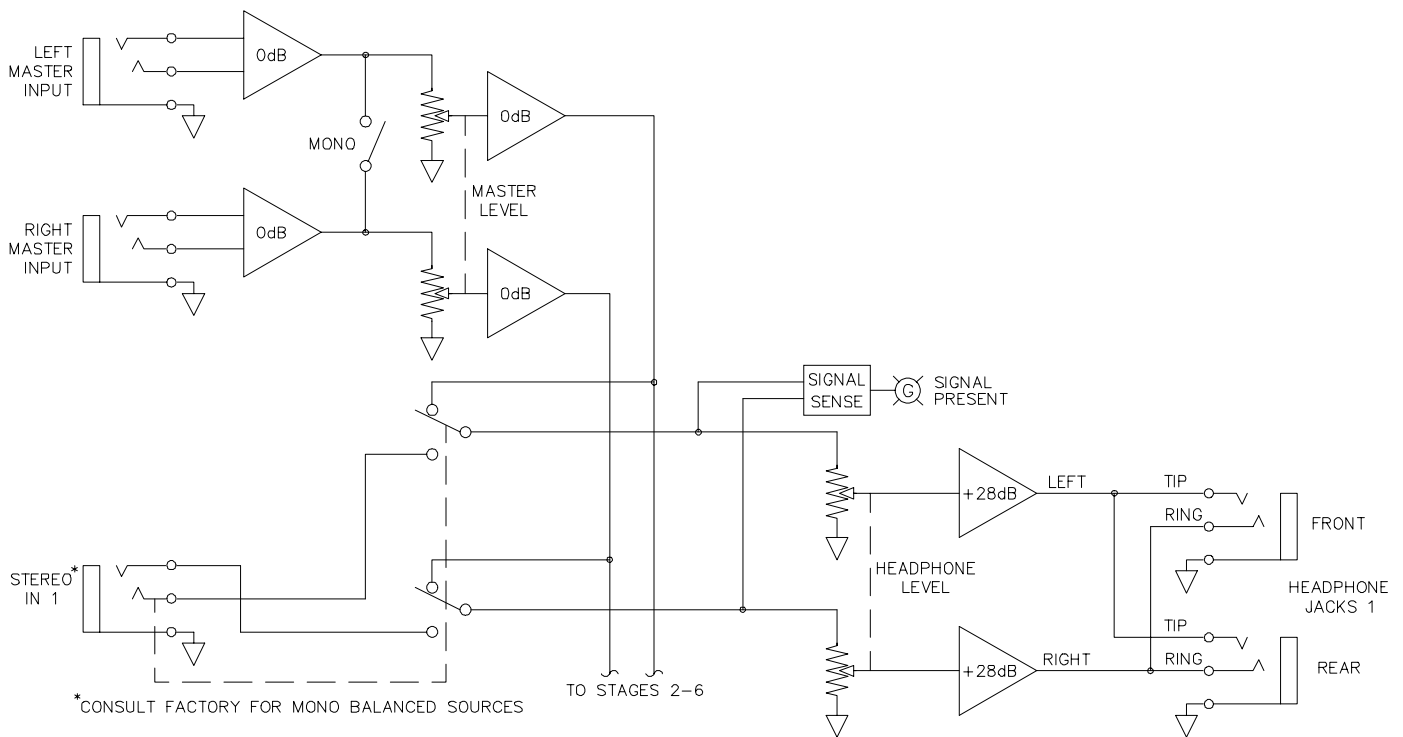

Application Information

At first glance the HC 6 looks like any other headphone distribution amplifier. Indeed, it performs superbly all the basic functions of such an instrument. Two balanced Inputs provide a master stereo signal to six stereo headphone amplifiers, with individual stereo Level controls. The Master Level control allows adjustment of the main stereo Input level for proper matching to any source. In addition, a Stereo/Mono switch converts the stereo Inputs to mono operation when required.

However, several unique features of the HC 6 allow performance well beyond the limits of standard headphone distribution amplifiers. Besides the stereo Master Inputs, the HC 6 provides separate stereo Inputs for each of the six headphone amplifiers. Whenever a signal is plugged into the individual stereo Input, the Master stereo signal automatically disconnects from that amplifier, allowing the remaining stages to be fed either from the Master stereo Inputs or likewise from another separate input. This feature opens new applications for the HC 6, allowing operation as either a standard distribution amplifier or as six separate amplifiers, or any combination of both. By connecting the six Inputs to a monitor mixing console, or to sub-master sends, or even to a patch bay, the HC 6 converts any size studio to a custom headphone monitor mixing system. You now can give each vocalist more of their voice for increased clarity; or add more kick drum to the bassist (without giving everyone else a headache); or let the producer monitor the straight mix all at

the same time. This feature proves equally valuable to broadcast facilities, video production studios, language labs and other educational facilities.

The HC 6 provides Output jacks on both the front and rear panels. The front jacks (paralleled with the rear jacks) add considerable flexibility and ease of operation. This feature allows permanent rack-mounting while maintaining instant access to any of the Outputs. Cueing becomes a snap; a must for monitor mix adjustments, and allows additional monitoring or routing without the use of a patch bay. Or, for language labs and other demo purposes, this feature means up to 12 headphones may be driven simultaneously.

The HC 6 makes a valuable tool for any band wanting to practice anywhere, anytime, at any volume, without disturbing a soul. By connecting the HC 6 directly to the mixer outputs and using headphones instead of amps and speakers, the entire band can perform at ear shattering levels, with no feedback, with amazingly cleaner, clearer sound. The HC 6 is a very cost-effective alternative to renting a practice studio for every rehearsal.

And finally, everyone wants to know how much power the HC 6 puts out. The output power depends on the impedance of the headphones; but, how much *power* the HC 6 puts out is the wrong question. How *loud* will the HC 6 make my headphones is the right question. See the RaneNote "Understanding Headphone Power Requirements" for the answer.

Rear Panel

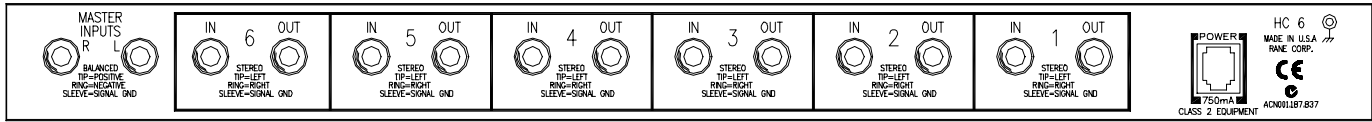

Architectural Specifications

The headphone console shall have six (6) stereo inputs and two (2) master inputs driving six (6) stereo amplifiers wired to six (6) outputs on the front panel, in parallel with six (6) outputs on the rear chassis. Sufficient output power shall be provided to drive most stereo headphones to levels of 120 dB SPL.

Automatic switching shall be included such that driving any of the separate inputs disconnects that one channel from the main stereo driving bus internally, allowing separate program material to be processed through the driven channel.

Input level controls shall be provided on all inputs with a gain range from off to +28 dB. A stereo/mono switch shall be

located on the front panel.

The master inputs shall be active balanced/unbalanced designs terminated with 1/4" TRS (tip-ring-sleeve) connectors. The outputs shall be 1/4" TRS connectors wired tip-left, ring-right, sleeve-common.

Ultrasonic filters shall be built-in, and LEDs provided to indicate Signal Present conditions on all amplifier inputs.

The unit shall be powered from a U.L. Listed, C.S.A. Certified, (120 VAC) external power supply, or a (230 VAC) supply meeting CE requirements. This external supply shall be provided with each unit.

The unit shall be a Rane Corporation Model HC 6.

References

1. D. Bohn, "Understanding Headphone Power Requirements," *Rane Note 100*, (1983).