

## General Description

The Rane ME 60 Stereo Interpolating Constant-Q Equalizer is a two Channel, 1/3-octave design, housed in a two rack-space unit. The ME 60 evolved by combining two ME 30B equalizers in one unit and then embellishing both. Two adjustable band limiting filters add to each channel's versatility, as well as the increased flexibility gained from the additional RCA input and output connectors. These extra features nicely complement the proven ME 30B design.

The active filter sections feature the GE 30's innovative interpolating constant-Q (constant bandwidth) design. Constant-Q means the bandwidth of each individual filter is guaranteed to be narrow enough to prevent unwarranted interaction between filters, yet wide enough to produce exactly the type of correction curve needed. This differs dramatically from proportional-Q designs encumbered with the unfortunate characteristic of changing bandwidth for every boost/cut level.

Aside from being a constant-Q device, the ME 60 also provides what Rane has dubbed "interpolating" performance. This means that when two adjacent bands are boosted or cut

to the same level, the response of the equalizer peaks (or interpolates a response) at a frequency centered between the filters. Interpolating performance allows effective control between ISO centers.

ME 60 front panel controls and indicators include an overall rotary Level control for each Channel as well as Overload indicators. Passive pushbutton Bypass switches feature LED indicators, avoiding ambiguity by being *on* when the unit is Bypassed. (A *passive* Bypass switch requires no power to operate. This allows restoration of the audio path should power fail in the ME 60.)

The rear of the ME 60 provides an unusually flexible array of connector choices. Inputs and Outputs are electronically balanced designs, capable of unbalanced operation when required. They accept and drive all possible signal levels into normal load impedances. Balanced applications choose between the 3-pin (XLR) or 1/4" Tip-Ring-Sleeve balanced connectors, while consumer products normally use the unbalanced RCA phono jacks. Unbalanced sources also may tie to the ME 60 through mono 1/4" connectors (no ring connection).

## Features

- Stereo 1/3-Octave Design
- $\pm 12$  dB Boost & Cut Range
- Interpolating Constant-Q Bandwidth
- Sweepable Low & High Cut Filters
- Channel 1 & 2 Level Controls
- Passive Bypass Switches
- 20 mm Filter Slide Controls
- Grounded Center Detents
- RFI Filters
- Balanced 3-Pin, 1/4" TRS, and Unbalanced RCA Connectors
- UL Listed for USA, cUL Listed for Canada (120 VAC)
- Meets CE Requirements for EMC and Safety (230 VAC)



Parameter	Specification	Limit	Units	Conditions/Comments
Equalizer:				
.....Channels	Two			
.....Bands	(2x30) 1/3-Octave ISO Spacing			From 25 Hz to 20 kHz
.....Type	Interpolating Constant-Q			Smooth Combining
.....Accuracy	3		%	Center Frequency
.....Travel	20		mm	Positive Grounded Center Detent
.....Range	±12	1	dB	
Inputs:				
.....Type	Active Balanced/Unbalanced			
.....Connectors	3-Pin, ¼" TRS & RCA			
.....Impedance	>20k Balanced	1%	ohms	
.....Maximum Level	+21	1	dBu	
Outputs:				
.....Type	Active Balanced/Unbalanced			
.....Connectors	3-Pin, ¼" TRS & RCA			
.....Impedance	200 Bal; 100 Unbalanced	1%	ohms	
.....Maximum Level	+21 Bal; +15 Unbalanced	1	dBu	2k ohms
	+19 Bal; +13 Unbalanced	1	dBu	600 ohms
Overall Gain Range	Off to +8 (Balanced Out)	min	dB	Sliders Centered
RFI Filters	Yes			
Passive Bypass Switches	Yes			
Overload LED Threshold	4	1	dB	Below Clipping
Low Cut Filter	10-250 Hz, 12 dB/Octave	3%	Hz	Butterworth
High Cut Filter	3k-40 kHz, 12 dB/Octave	3%	Hz	
Frequency Response	20-20 kHz	±0.5	dB	
	10-40 kHz	+0/-3	dB	
THD & Noise	0.008	.002	%	+4 dBu, 20-20 kHz
IM Distortion (SMPTE)	0.005	.003	%	60 Hz / 7 kHz, 4:1, +4 dBu
Signal-to-Noise Ratio	re +20 dBu / +4 dBu			20 kHz Noise BW; Balanced Out
	112 / 96	2	dB	Sliders Centered, Unity Gain
Channel Separation	75	3	dB	1 kHz
Common Mode Rejection	46	1	dB	1 kHz
Maximum Power	12		W	
Line Voltage:				
.....Domestic	105-130 VAC, 50/60 Hz			
.....Export	205-250 VAC, 50 Hz			
Unit: Agency Listing				
.....120 VAC model	UL cUL (Canada)			UL 813 (file E104174) C22.2 (file E104174)
.....230 VAC model	CE-EMC Certified (EN55013 and EN55020) CE-Safety Certified (EN60065)			EMC directive 89/336/EEC LV directive 73/23/EEC
.....Construction	All Steel			
.....Size	3.5" H x 19" W x 8.5" D (2U)			(8.9 cm x 48.3 cm x 21.6 cm)
.....Weight	9 lb			(4.1 kg)
Shipping:				
.....Size	4.5" x 20.3" x 13.75"			(11.5 cm x 52 cm x 35 cm)
.....Weight	12 lb			(5.0 kg)
Note: 0 dBu=0.775 Vrms				

### Block Diagram

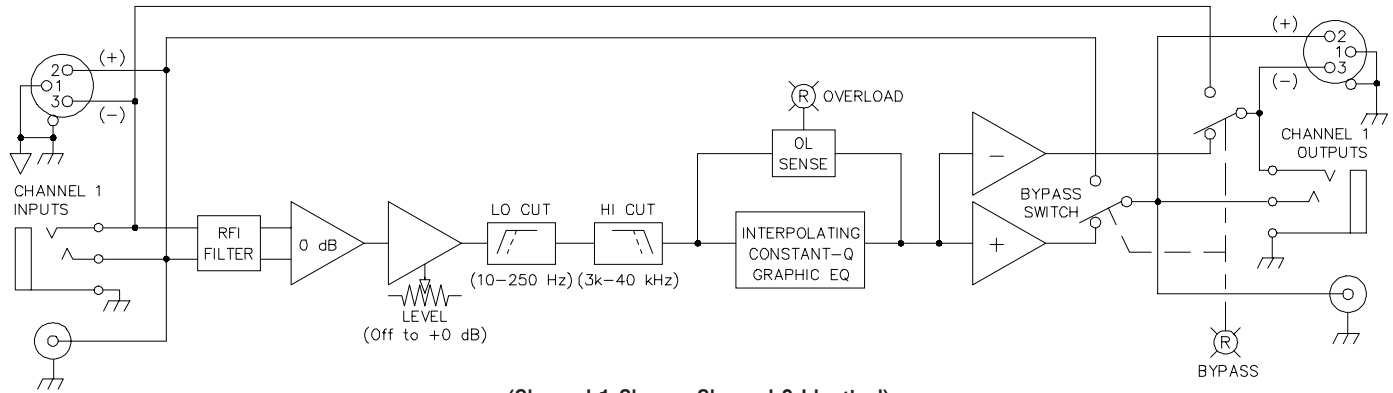

(Channel 1 Shown, Channel 2 Identical)

### Application Information

The ME 60 offers the same high quality interpolating constant-Q performance as its relative, the GE 30. No compromises or trade-offs exist in selecting the ME 60. It is constructed using only precision audio-grade components and advanced integrated circuits, all assembled onto mil-spec glass-epoxy printed circuit boards.

The adjustable filters are useful when it is desirable to band limit the audio signal. For instance, restricting high frequencies to match the incoming signal usually produces the most quiet system. And a common use for the Low Cut filter is limiting the signal going to 70 volt speaker systems. Often low frequencies saturate the loudspeaker transformers. Restricting these signals greatly improves system intelligibility. Full bandwidth use requires positioning both sliders to their lower limits. This effectively removes the filters and guarantees 20-20 kHz  $\pm 0.5$  dB performance.

The interpolating constant-Q performance of the ME 60 arose from the sound professional's need for greater control with less interaction than previously possible with conventional equalizers. Truth in slider position became a requirement. The curve traced out by the slider positions on constant-Q designs indeed represents the actual changes to the frequency response. On conventional designs they do not. Combine this feat with the Rane-developed "interpolating" characteristic and you have a tool without peer.

The ME 60 goes one step further toward being the best device for any application. It offers the choice of all common audio input and output connectors. The inclusion of 3-pin XLR, 1/4" TRS and RCA Input and Output connectors ensures acceptance in all installations.

### CONSTANT-Q DETAILS

Traditional equalizer designs present a problem in that the filter's level control is actually a part of the filter. Consequently, whenever the slider is moved, the bandwidth changes. The output exhibits the desired bandwidth only at full boost or cut. It degrades to as much as two octaves at moderate slider settings. Responding to this dilemma, Rane developed a topology ensuring constant filter bandwidth ("Q") at all slider positions.

Another important advantage of constant bandwidth is reduction of adjacent filter overlap. Conventional designs exhibit excessive overlap at moderate slider settings. Adjusting one slider affects the adjacent neighbors, requiring readjustments to each. Filter overlap in Rane equalizers is dramatically less, reducing the need for constant readjustment of adjacent sliders. This means more effective equalization in significantly less time.

### INTERPOLATING DETAILS

Today's sophisticated acoustic measurement tools show exact trouble spots. Often these lie between ISO centers. An interpolating equalizer allows correction for these response errors by producing a smooth peak or dip between (i.e., it interpolates, or inserts between) any two adjacent frequency sliders when they are raised or lowered the same amount. Non-interpolating responses exhibit a slight dip (ripple) under similar conditions.

## Rear Panel

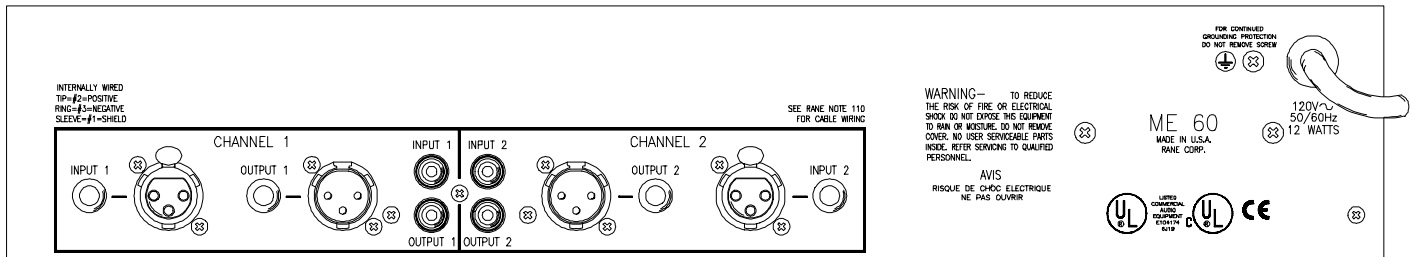

## Architectural Specifications

The graphic equalizer shall be a two channel model of interpolating constant-Q design to minimize interactions between adjacent bands, and shall occupy two rack spaces (2U). Each channel shall have thirty (30) frequency bands located on standard ISO center frequencies. Each band shall have a bandwidth of 1/3-octave. A detented and positively grounded 0 dB point shall be provided on 20 mm linear sliders with dust dams.

Low and high cut filters shall be provided with 12 dB/octave slopes and adjustable corner frequencies. A rotary overall level control shall be provided with a range from off to +8 dB of gain when used in balanced mode.

The inputs shall be active balanced/unbalanced designs terminated with 3-pin, 1/4" TRS (tip-ring-sleeve), and RCA connectors. The outputs shall be active balanced/unbalanced with equal output impedances terminated with 3-pin, 1/4" TRS, and RCA connectors. RFI filters shall be provided. The unit shall provide a passive bypass feature for each channel requiring no power to operate. LEDs shall be provided to indicate overload and bypass conditions.

The 120 VAC 50/60 Hz model shall be UL and cUL listed and operate by means of its own built-in power supply. The 230 VAC 50 Hz model shall meet the European requirements for EMC and safety and carry the CE mark of compliance. The unit shall be constructed entirely from cold-rolled steel.

*The unit shall be a Rane Corporation ME 60 microGraphic Equalizer.*

## Available Accessories

- SC 3.5 Security Cover

## References

1. D. Bohn, "Constant-Q Graphic Equalizers," *Rane Note 101*, (1982).
2. D. Bohn, "A New Generation of Filters," *Sound and Video Contractor*, vol. 2, pp. 36-39 (Feb. 1984).
3. T. Pennington, "Constant-Q," *Studio Sound*, vol.27, pp. 82-85 (Oct. 1985).
4. D. Bohn, "Constant-Q Graphic Equalizers," *J. Audio Eng. Soc.*, vol. 34, pp. 611-626 (September 1986).
5. D. Bohn, "Exposing Equalizer Mythology," *Rane Note 115*, (1986).
6. D. Bohn, "Operator Adjustable Equalizers," *Rane Note 122*, (1990).