

# Mojo Cans Amp

**MH 4**

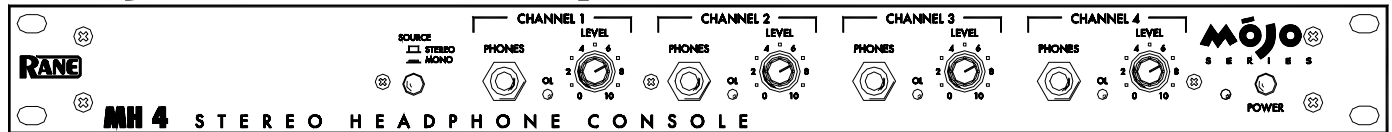

## STEREO HEADPHONE AMPLIFIER

### General Description

Very simple. You and up to three other friends want to listen to the same mix under headphones. Just take the MH 4, plug in, turn on, adjust your individual volumes, and groove.

The MH 4 provides master stereo Inputs which can be used to drive the four stereo headphone amplifiers. A Mono switch is provided on the front panel to drive both channels of all four amplifiers from a common mono source.

The MH 4 is capable of delivering up to 200 milliwatts into headphones with rated impedances between 32-600 ohms. The precise amount of power depends on the exact impedance of the headphone in use and the number of

headphones connected to the unit. Under most conditions, the MH 4 produces sound pressure levels in excess of 120 dB. This level is above the threshold of pain and is suitable for most listeners. See the RaneNote, "Understanding Headphone Power Requirements" for further information.

The Rane Mojo Series maintains sonic and construction quality not found (until now) in this price range. Designed for the working musician...simple operation...reduced features...without compromise in audio quality or dependability.

### Features

- Four Stereo Amplifiers
- Balanced 1/4" Stereo Master Inputs
- Extremely Low Noise
- Stereo/Mono Switchable
- Master Balanced/Unbalanced 1/4" TRS Stereo Inputs
- Individual Level Controls and Overload Indicators
- Drives 32-600 ohm Headphones
- Drives Most Phones to 120 dB SPL
- UL/CSA Remote Power Supply (120 VAC)
- CE (Low Voltage & EMC) Remote Power Supply (230 VAC)

## MH 4 Stereo Headphone Amplifier Features and Specifications

Parameter	Specification	Limit	Units	Conditions/Comments
Headphone Impedance Range	32-600	10%	ohms	For Best Performance
Inputs: Type	Active Balanced/Unbalanced			
.....Connectors	¼" TRS			
.....Impedance	20k	1%	ohms	
.....Maximum Level	+20	1	dBu	
Outputs: Type	(4) Stereo Amplifiers			
.....Connectors	¼" Tip = Left, Ring = Right			
.....Impedance	1	max.	ohm	
Power	200	min.	mw	32 to 150 ohms
Overall Gain Range	Off to +26	±0.5	dB	
LED Overload	3	min.	dB	Before Clipping
Frequency Response	10-45 kHz	+0/-3	dB	
Common Mode Rejection Ratio	40	min.	dB	20 Hz-20 kHz
THD+Noise	0.1	max.	%	re 200 mW/150 ohms
Crosstalk, Left to Right	-50	max.	dB	re 200 mW/150 ohms, 20 Hz-20 kHz
Signal-to-Noise Ratio	94	min.	dB	re 200 mW/150 ohms, 20 kHz BW
Unit: Agency Listing				
.....120 VAC model	Class 2 Equipment UL 813 Exempt CSA Exempt			National Electrical Code Class 2 Class 2
.....230 VAC model	VDE, SELV CE (EMC) CE (Safety) Exempt			Safety Extra-Low Voltage EMC Directive 89/336/EEC Article 1 of LV directive 73/23/EEC
Power Supply: Agency Listing				
.....120 VAC model	UL Listed CSA Certified			File no. E88261 File no. LR58948
.....230 VAC model	CE (EMC) CE (Safety)			EMC Directive 89/336/EEC Article 1 of LV directive 73/23/EEC
.....Requirement	18 VAC with Center Tap	10%	Vrms	Rane RS 1 Supplied
.....Maximum Current	750		mA	RMS Current From Remote Supply
Unit: Construction	All Steel			
.....Size	1.75"H x 19"W x 5.3"D (1U)			(4.4 cm x 48.3 cm x 13.5 cm)
.....Weight	6 lb			(2.7 kg)
Shipping: Size	4.5" x 20.3" x 13.75"			(11.4 cm x 52 cm x 35 cm)
.....Weight	12 lb			(5.4 kg)
Note: 0 dBu = 0.775 Vrms				

## MH 4 Block Diagram

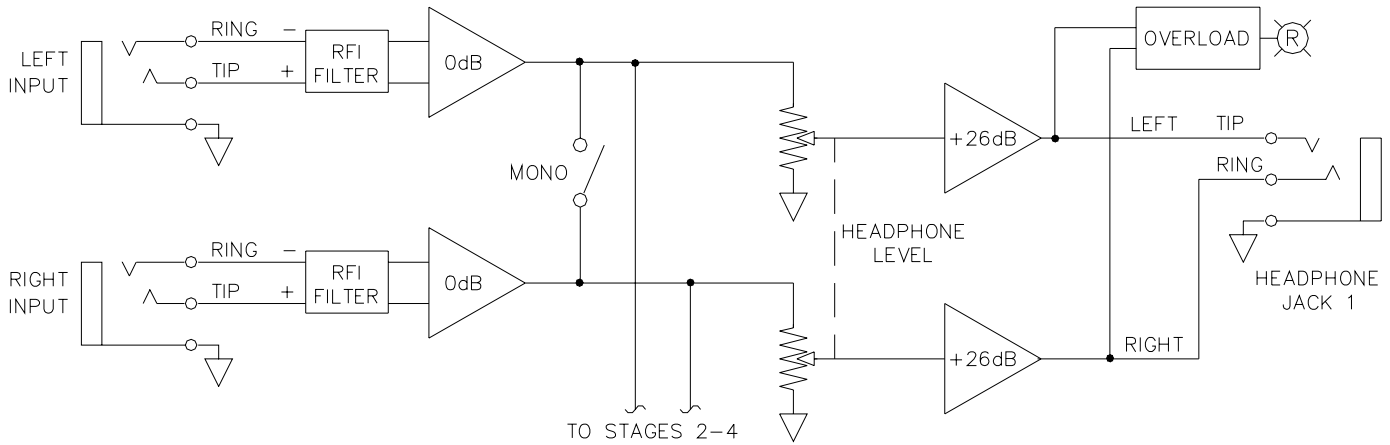

## Application Information

Two balanced Inputs provide a master stereo signal to four stereo headphone amplifiers, with individual stereo Level controls and Overload indicators. The Master Level control allows adjustment of the main stereo Input level for proper matching to any source. In addition, a Stereo/Mono switch converts the stereo Inputs to mono operation when required.

The MH 4 makes a valuable tool for any band wanting to practice anywhere, anytime, at any volume, without disturbing a soul. By connecting the MH 4 directly to the mixer outputs and using headphones instead of amps and speakers, the entire band can perform at ear shattering levels,

with no feedback, with amazingly cleaner, clearer sound. The MH 4 is a very cost-effective alternative to renting a practice studio for every rehearsal.

And finally, everyone wants to know how much power the MH 4 puts out. The output power depends on the impedance of the headphones; but, how much *power* the MH 4 puts out is the wrong question. How *loud* will the MH 4 make my headphones is the right question. See the RaneNote “Understanding Headphone Power Requirements” for the answer.

## MH 4 Rear Panel

<p>POWER 1750mA CLASS 2 EQUIPMENT</p>	<p><b>WARNING—</b> TO REDUCE THE RISK OF ELECTRICAL SHOCK DO NOT EXPOSE THIS EQUIPMENT TO MOISTURE. DO NOT REMOVE COVER. NO USER SERVICEABLE PARTS INSIDE. REFER SERVICING TO QUALIFIED PERSONNEL.</p>	<p>CONNECTION INFORMATION</p> <p>INPUT - 1/4" INCH PHONE JACKS, BALANCED SLEEVE = SHIELD, TIP = POSITIVE (+), RING = NEGATIVE (-) 1/4" INCH PHONE JACKS, UNBALANCED TIP = HOT (SIGNAL), RING = GROUND, SLEEVE = GROUND</p> <p>OUTPUT - 1/4" INCH HEADPHONE JACKS (FRONT PANEL) TIP = LEFT, RING = RIGHT, SLEEVE = GROUND</p> <p>PLEASE REFER TO OWNERS MANUAL FOR MORE INFORMATION</p>	<p>INPUTS</p> <table border="0"> <tr> <td data-bbox="917 535 998 619"> <p>LEFT BAL/UNBAL</p> </td> <td data-bbox="1047 535 1128 619"> <p>RIGHT BAL/UNBAL</p> </td> </tr> </table>	<p>LEFT BAL/UNBAL</p>	<p>RIGHT BAL/UNBAL</p>	<p>MH 4 MADE IN U.S.A. RANE CORP. CE ACN001187837</p>
<p>LEFT BAL/UNBAL</p>	<p>RIGHT BAL/UNBAL</p>					

## Architectural Specifications

The headphone console shall have two (2) master inputs driving four (4) stereo amplifiers wired to four (4) outputs on the front panel. Sufficient output power shall be provided to drive most stereo headphones to levels of 120 dB SPL.

Input level controls shall be provided on all inputs with a gain range from off to +26 dB. A stereo/mono switch shall be located on the front panel.

The master inputs shall be active balanced/unbalanced designs terminated with 1/4" TRS (tip-ring-sleeve) connectors.

The outputs shall be 1/4" TRS connectors wired tip-left, ring-right, sleeve-common.

LEDs shall be provided to indicate overload conditions on each amplifier input.

The unit shall be powered from a U.L. Listed, C.S.A. Certified, (120 VAC) external power supply, or a (230 VAC) supply meeting CE requirements. This external supply shall be provided with each unit.

*The unit shall be a Rane Corporation Model MH 4.*