

General Description

The Rane MLM 103 Mic/Line mixer features six balanced, studio-grade microphone inputs and two balanced, stereo line-level inputs. The microphone preamplifiers feature direct outputs. These can monitor the signal ‘pre’ or ‘post’ the mix Level control via rear panel switches. Each microphone and *stereo* line input features three-band EQ and mix level controls. Input overload indicators are peak detecting and illuminate 4 dB before clipping. Three balanced outputs are provided. A and B outputs may be used as a stereo pair in a single zone or as two independent mono zones. The AUX output is mono. All connections are via Euroblock connectors.

Inputs 1 through 6 may be individually switched between Mic or Line level via rear panel switches. Inputs operate in Mic mode with a gain range of +15.5 dB to 60 dB. Each *pair* of inputs may operate with or without 12 volt phantom power via rear panel switches. When Inputs are operated in Line

mode, the gain range is 0 to 12 dB. When Line mode is selected, phantom power is defeated. Each input may be assigned to the A, B or AUX output.

Stereo Line Inputs 7 through 10 accommodate +24 dBu signal levels. The gain range is $-\infty$ to +12 dB. The A/B assign switch for inputs 7/8 assigns 7 to output A and 8 to output B. The A/B assign switch for inputs 9/10 assigns 9 to output A and 10 to output B. The mono switch sends the *sum* of inputs 7 and 8 (or 9 and 10) to bus A and bus B. Assigning 7/8 or 9/10 to AUX sends the *sum* of input 7 and 8 (or 9 and 10) to the AUX output.

The A, B and AUX outputs feature independent level controls and 10 segment meters with peak hold. Each balanced output provides an additional 6 dB of gain and delivers a minimum signal level of +24 dBu into a 10k ohm load.

The MLM 103 features an *internal* high efficiency, universal voltage power supply.

Features

- **Six Studio-grade Mic Preamplifiers**

- Mic or Line-level Operation
- +12 volt Phantom Power
- Continuously Variable Gain Trim
- Direct Outputs (pre- or post- mix level)
- A/B/AUX Assign Switches
- Input Overload Indicator

- **Two Balanced Stereo Line-level Inputs**

- Mono Switch
- A/B/AUX Assign Switch
- Input Overload Indicator

- **A/B/AUX Balanced Outputs**

- Independent Level Control
- 10-Segment Meter with Peak Hold

- **85-260 VAC Universal Power Supply**



Features and Specifications

Parameter	Specification	Limit	Units	Conditions/Comments
Mic Inputs: Type	Active balanced			
.....Connectors	Euroblock			
.....Input Impedance Mic Mode	1.49 k	1%	ohms	745 ohms each leg, 1 kHz
.....Input Impedance Line Mode	8 k	1%	ohms	4 k ohms each leg, 1 kHz
.....Gain Range Mic Mode	15.5 to 60	2	dB	Min/max, 1 kHz
.....Max Input Mic Mode	+4.5 / -40		dBu	Min/max gain, 1 kHz
.....Gain Range Line Mode	-0.7 / +12	1	dB	Min/max, 1 kHz
.....Max Input Line Mode	+20.7 / +8		dBu	Min/max gain, 1 kHz
.....Frequency Response	10 Hz-50 kHz	+5,-3	dB	Mic gain=60 dB
	30 Hz-50 kHz	+5,-3	dB	Mic gain=15.5 dB
.....Equivalent Input Noise	-128	max	dBu	Mic gain 60 dB, Rs=150 ohms, 20Hz-20kHz
.....Common Mode Rejection	60	min	dB	1 kHz, Rs=150 ohms
.....THD+N	0.01	typ	%	Mic gain=40 dB, +4 dBu, 20 Hz-20 kHz
.....Phantom Power	12	5%	VDC	Disabled in Line mode
Stereo Line Inputs: Type	Active balanced			
.....Connectors	Euroblock			
.....Input Impedance	10 k	1%	ohms	Each leg, common mode or differential
.....Gain Range	-infinity to +12	typ.	dB	1 kHz
.....Maximum Input	+24 / +12		dBu	Min/max gain, 1 kHz
.....Frequency Response	10 Hz-50 kHz	+5/-3	dB	
.....Common Mode Rejection	40	min	dB	1 kHz, Rs=150 ohms
.....THD+N	0.005	typ	%	20 Hz-20 kHz, +4 dBu, Load=10 k ohms
Tone Controls: Type	Baxandall			2 stage, bass and treble shelving
.....Boost/Cut Range	±12	typ	dB	All filters
.....Low	±6	typ	dB	Boost/cut at 300 Hz
.....Mid	±6	typ	dB	Boost/cut at 300 Hz & 3.3 kHz, center 1 kHz
.....High	±6	typ	dB	Boost/cut at 3.3 kHz
Outputs: Type	Active balanced			
.....Connector	Euroblock			
.....Output Impedance	200	1%	ohms	100 ohms each leg, 1 kHz
.....Maximum Output	+24	min	dBu	Load=10 k ohms, 1 kHz
.....Noise Floor	-100	typ	dB	No inputs assigned
	-89	typ	dB	Any line-level input assigned, output levels at max, 20 Hz to 20 kHz, re +4 dBu
.....Crosstalk	-80	max	dB	Any input to any output @ 1 kHz
.....Control Feed-through	-80	max	dB	All front panel assign and level controls
Meters: Type	Average dBu			
.....Range	-20 to +10		dBu	
.....Number of Segments	10			
.....Peak Hold	1 sec			
Power Supply Requirement				85 to 260 VAC, 50/60 Hz, .24 amp
Unit: Agency Listing				UL/CSA/CE pending
Unit: Construction	All Steel			
.....Size	5.25"H x 19"W x 5.3"D (3U)			13.3 cm x 48.3 cm x 13.5 cm
.....Weight	TBD			TBD
Shipping: Size	11" x 23" x 16"			27.9 cm x 58.4 cm x 40.6 cm
.....Weight	TBD			TBD

Note: 0 dBu=0.775 Vrms

Block Diagram

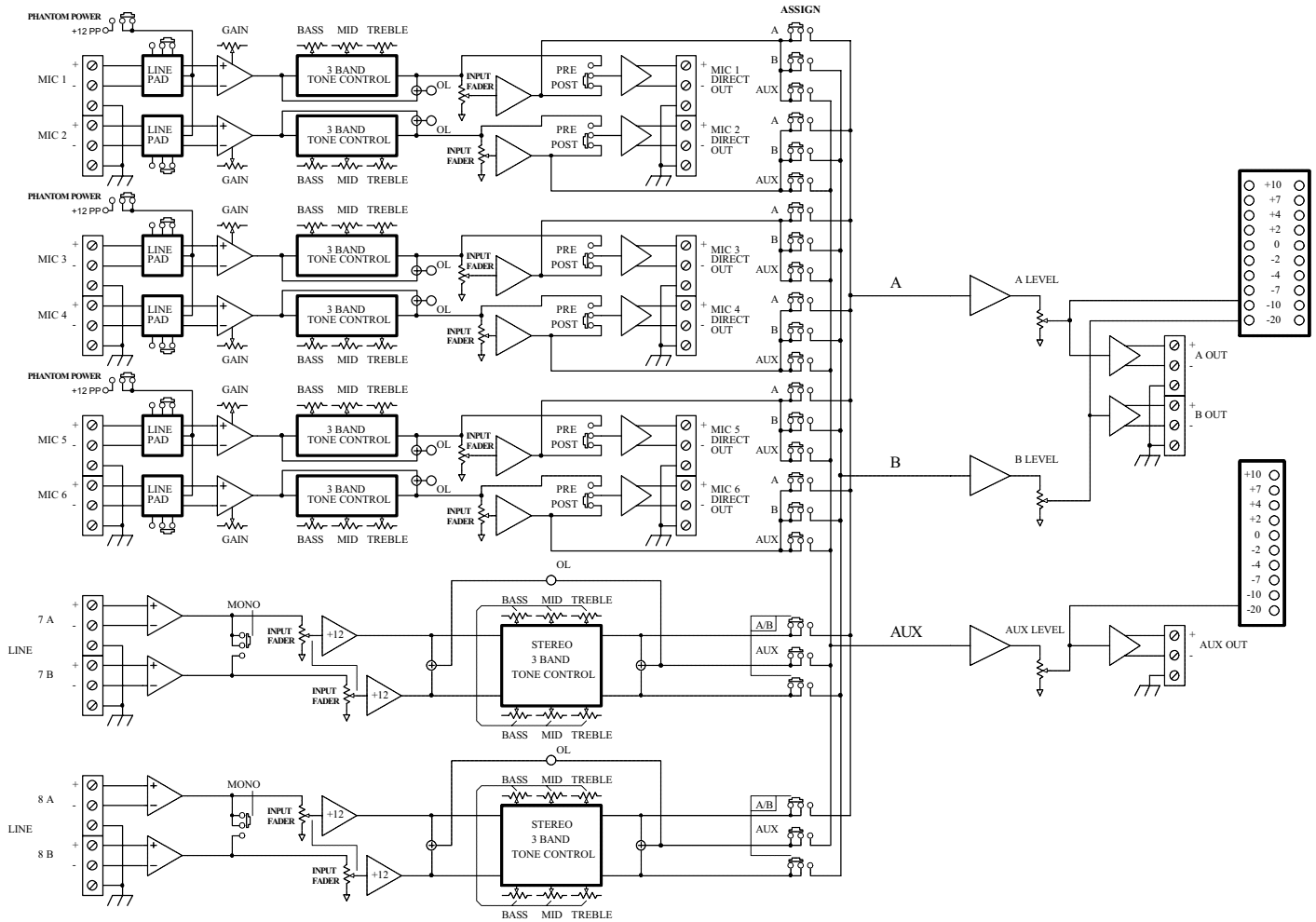

Applications

Applications include, but are not limited too, hotels, churches, conference rooms, schools and rental sound systems. The direct outputs may be used with the Rane SRM 66 Splitter/Router/Mixer for applications requiring room combining and/or flexible zone distribution. The studio-grade specifications of the MLM 103 allow many other applications such as sub-mixing, recording and post-production.

Rear Panel

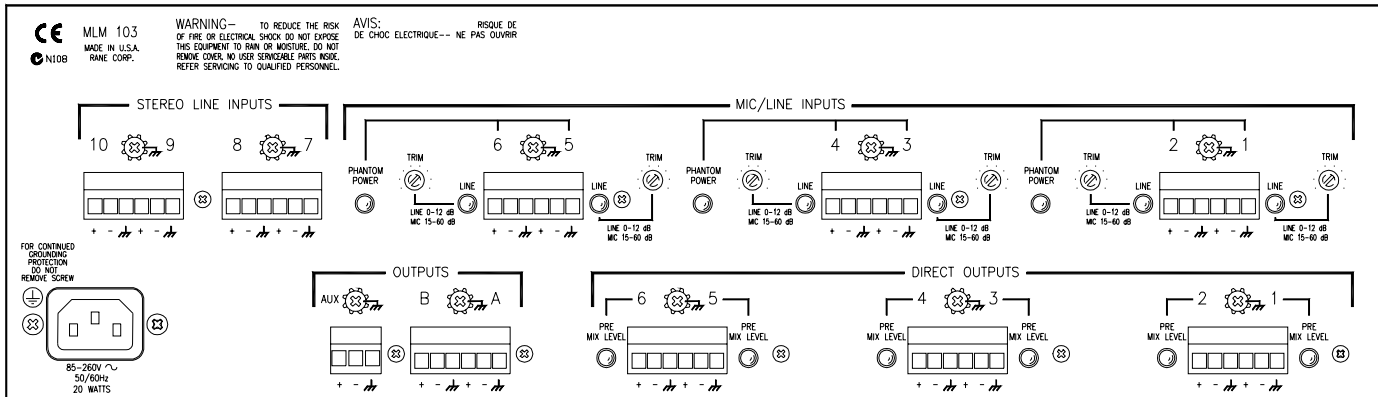

Architectural Specifications

The Mixer shall be a high performance Mic/Line Mixer featuring six balanced, studio-grade microphone inputs and two balanced, stereo line-level inputs. The microphone preamplifiers shall feature direct outputs able to monitor the signal pre- or post- the mix Level control. Each microphone and *stereo* line input shall feature three-band EQ and mix level controls. Peak detecting input overload indicators shall be provided. The Mixer shall have A, B and AUX outputs with independent level controls and 10 segment level meters with peak hold. Each balanced output shall provide an additional 6 dB of gain and deliver a minimum signal level of +24 dBu into a 10k ohm load. All connections shall be via Euroblock connectors.

Microphone inputs shall operate in Mic mode with a gain range of +15.5 dB to 60 dB. Each *pair* of microphone inputs

may operate with or without 12 volt phantom power. Each microphone input shall be capable of line-level operate with a gain range of 0 to 12 dB. If Line mode is selected, phantom power is defeated. Each microphone input may be assigned to the A, B or AUX output bus.

Stereo Line inputs shall accommodate +24 dBu signal levels with a gain range is - to +12 dB. Each stereo line input shall feature a mono switch, A-B and AUX assign switch.

The Mixer shall feature a high efficiency, universal voltage power supply capable of operating from 85 to 260 VAC, 50-60 Hz. The unit shall feature an IEC socket and line cord. The unit shall meet UL/CSA and CE safety requirements. The unit shall be constructed of cold-rolled steel and mount into a standard 19" 3U EIA rack.

The unit shall be a Rane MLM 103 Mic/Line Mixer.

Available Accessories

- MLM 103 EQ/Assign security cover
- SC 3.5 Double Space Security Cover