



RRVE320DHC

CASE FOR MIDAS VENICE 320 MIXING BOARD W/ CASTERS & DOGHOUSE



Rugged Road Ready Features

- * Beefy, Stackable Ball Corners
- * Double Anchor Industrial Rivets
- * Recessed, Industrial Grade Latches
- * Recessed Industrial Grade Handle
- * Industrial Grade Rubber Feet
- * Premium 3/8" Vinyl Laminated Plywood
- * Tongue and Groove Locking Fit
- * Low Profile Base
- * Doghouse
- * Beefy 3 1/2" Caster
- * ATA 300 Rating
- * Road Ready Limited Lifetime Warranty

Product Dimensions

Shipping Dimensions (inch): 39.1 x 36.6 x 11.8

Shipping Weight (lbs): 69

Product Dimensions (inch): 38.5 x 36 x 11

Product Weight (lbs): 64.7

Shipping Dimensions (cm): 99.5 x 93 x 30

Shipping Weight (kg): 31.4

Product Dimensions (cm): 98 x 91.5 x 28

Product Weight (kg): 29.4

Created for the Pro's, the RRVE320DHC mixer case is made for the journey and built to hold strong in high stress situations. Designed to fit the Midas Venice 320 Mixing Board, the RRVE320DHC features a heavy-duty, removable, cover crafted with our no-pressure design to protect your mixer controls and our unique low profile base that allows you to access the mixer's controls with ease. We also included a doghouse so you could get a grip on all your connections and throw in a rugged 3 1/2" caster for easy mobility. Tougher than the pavement! That's the idea.

Road Ready Cases

1226 Corral Place * Santa Fe Springs, CA 90670

ph: 562.906.6185 * fax: 562.906.6186

WWW.ROADREADYCASES.COM

RRVE320DHC

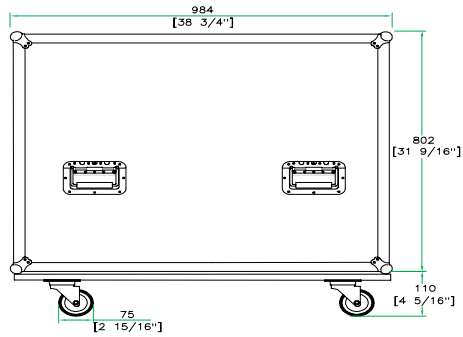

FRONT VIEW

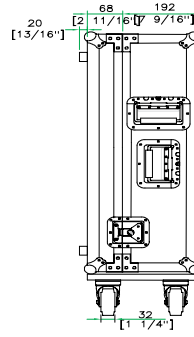

LEFT VIEW

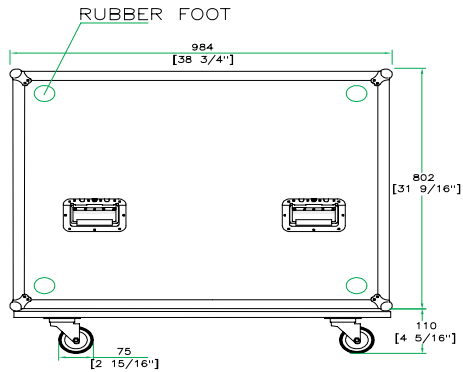

BACK VIEW

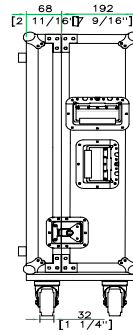

RIGHT VIEW

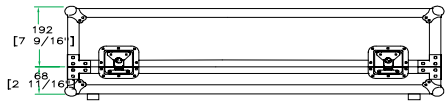

TOP VIEW



A-A VIEW

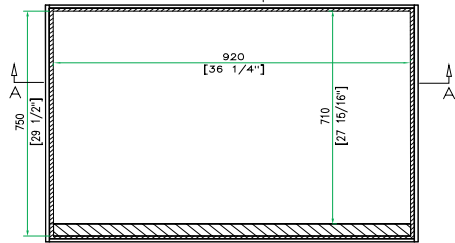

TOP VIEW OF COVER

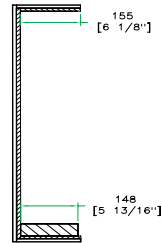

B-B VIEW

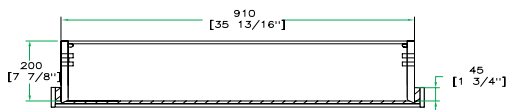

C-C VIEW

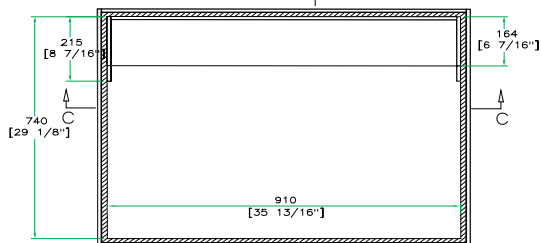

TOP VIEW OF COVER

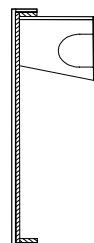

D-D VIEW

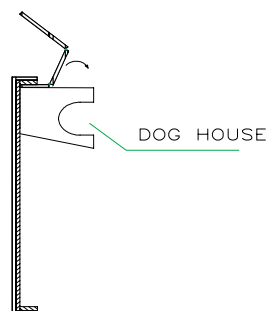

DOG HOUSE