

0102 - SURFACE MOUNTED SPEAKER SYSTEMS

01

LOUDSPEAKER ASSEMBLIES

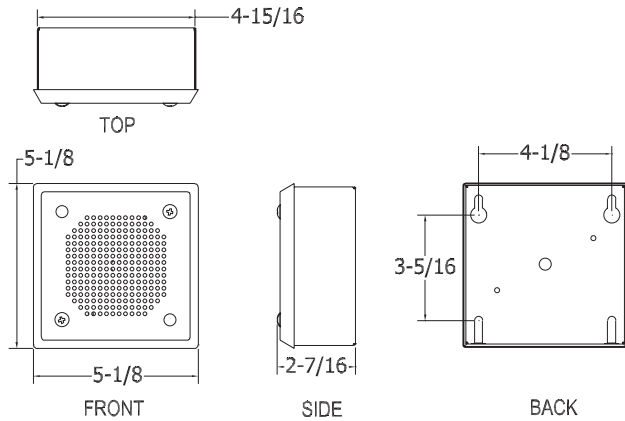

GENERAL DESCRIPTION

The Quam SYSTEM 7DT is a complete loudspeaker assembly, with 4" frame loudspeaker - 8 Ohm operation and steel enclosure. Finish: Black baked epoxy hybrid.

INTENDED USE

Drive-thru menu board, vertical surface mount, in an indoor or protected outdoor environment. Program Material: Signal tones and voice

SYSTEM COMPONENTS

Loudspeaker	4C3Z8OT
Enclosure	SYSTEM 7DT

RECOMMENDED ADDITIONAL QUAM COMPONENTS

None required

AUDIO SPECIFICATIONS

Speaker Size	4" Frame
Average Sensitivity	91 dB SPL, 1W / 1M
Power Rating	10W RMS, EIA 426A Standard
Calculated Output	98 dB SPL, 5W / 1M
Frequency Response	130 Hz - 9 kHz EIA 426A Standard
Nominal Coverage Angle	90° Included Angle, -6 dB / 2 kHz, Half Space
Audio Connection	15" Long Tinned Wires, Pre-cut

Recommended construction sequences, installation instructions and A&E Specifications are available in various formats on the Quam Architects' and Engineers' Resources CD or on the web at www.quamspeakers.com

Quam-Nichols Company

234 East Marquette Road, Chicago, IL 60637
 Phone (800) NEED NOW Fax (888) NEED NOW
 (800) 633-3669 (888) 633-3669
 E-Mail: neednow@qnc.com www.quamspeakers.com

