

LIMITED WARRANTY

This product is warranted to the original consumer purchaser to be free from defects in materials and workmanship under normal installation, use and service for a period of one (1) year from the date of purchase as shown on the purchaser's receipt.

The obligation of Rolls Corporation under this warranty shall be limited to repair or replacement (at our option), during the warranty period of any part which proves defective in material or workmanship under normal installation, use and service, provided the product is returned to Rolls Corporation, TRANSPORTATION CHARGES PREPAID. Products returned to us or to an authorized Service Center must be accompanied by a copy of the purchase receipt. In the absence of such purchase receipt, the warranty period shall be one (1) year from the date of manufacture.

This warranty shall be invalid if the product is damaged as a result of defacement, misuse, abuse, neglect, accident, destruction or alteration of the serial number, improper electrical voltages or currents, repair, alteration or maintenance by any person or party other than our own service facility or an authorized Service Center, or any use violative of instructions furnished by us.

This one-year warranty is in lieu of all expressed warranties, obligations or liabilities. ANY IMPLIED WARRANTIES, OBLIGATIONS, OR LIABILITIES, INCLUDING BUT NOT LIMITED TO THE IMPLIED WARRANTIES OF MERCHANTABILITY AND FITNESS FOR A PARTICULAR PURPOSE, SHALL BE LIMITED IN DURATION TO THE ONE YEAR DURATION OF THIS WRITTEN LIMITED WARRANTY. Some states do not allow limitations on how long an implied warranty lasts, so the above limitation may not apply to you.

IN NO EVENT SHALL WE BE LIABLE FOR ANY SPECIAL, INCIDENTAL OR CONSEQUENTIAL DAMAGES FOR BREACH OF THIS OR ANY OTHER WARRANTY, EXPRESSED OR IMPLIED, WHATSOEVER. Some states do not allow the exclusion or limitation of special, incidental or consequential damages so the above limitation or exclusion may not apply to you. This warranty gives you specific legal rights, and you may also have other rights which vary from state to state.

ADB2 Active Direct Box

- Uses standard 9 - 48 volt phantom power for supply
- Ground Lift for "hum" reduction
- Attenuator switch for connection to line level or speaker level signals

The ADB2 is an active direct box for converting a high impedance signal such as a direct out from a bass amplifier, to a low impedance signal such as a snake input and a mixer's microphone input. The Ground Lift is provided to reduce possible ground hum or buzz.



Rolls Corporation
Salt Lake City, UT
9/95

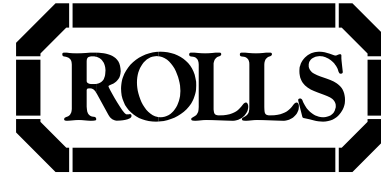

ADB2 PHANTOM Direct Box

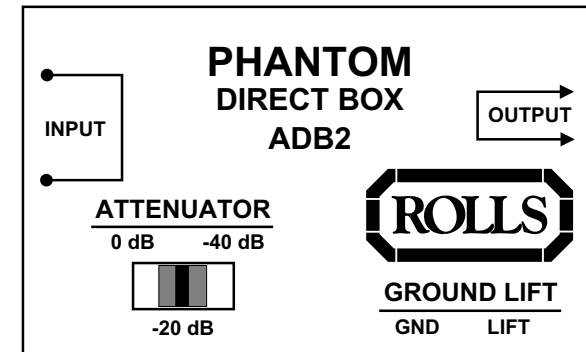

Owners Manual

Congratulations and thank you for your purchase of the ADB2 Phantom. The ADB2 is designed to provide lasting value and usefulness. It is intended for sending unbalanced signals (up to +40 dB) to a mixing console or other professional input device. The unit has no transformer, so stray field pickup is nonexistent. The ADB2 is powered by standard microphone phantom power from 9 - 48 VDC and uses discrete low-noise differential drivers to make it very quiet. The unit has two 1/4" input jacks wired in parallel, a male XLR output jack, a ground lift switch, and a three-position attenuator switch.

DESCRIPTION

INPUTS: Two 1/4" unbalanced jacks - wired together in parallel. For connection to line or instrument level signals.

OUTPUT: One male XLR jack for connection to mixing console or other input device carrying phantom power.

ATTENUATOR SWITCH: Decreases the input signal by the indicated amount. At 0 dB the signal is not attenuated, at the 20 and 40 dB settings, the signal is dropped by that amount.

GROUND LIFT: Removes the ground connection of the 1/4" and XLR jacks from the chassis ground.

INSTALLATION

In order for the ADB2 to function it must be connected to a microphone phantom power source with a balanced XLR cord. The input may be anything from a speaker source such as a music amplifier, VCR or projector, to an instrument such as a guitar or High-impedance microphone. Care should be taken to overdrive the ADB2 or there will be a distorted sound from the unit. Use the lowest attenuator setting that gives distortion free sound. The ground lift switch should be in the position that yields the lowest noise.

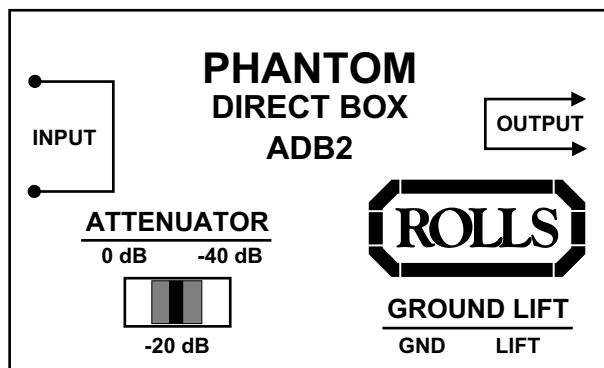

SPECIFICATIONS

Input Level: -10 to +40 dB unbalanced
 Output Level: -10 to +2 dB balanced XLR Male (pin 2 +)
 Bandwidth: 1 Hz to 50 kHz
 S/N Ratio: 100 dB
 Jacks: (2) 1/4" phone, (1) XLR male
 Conrols: Attenuator switch, Ground Lift switch,
 Power: 9 - 48 VDC Phantom Powered
 Size: 2" x 3.5" x 5"

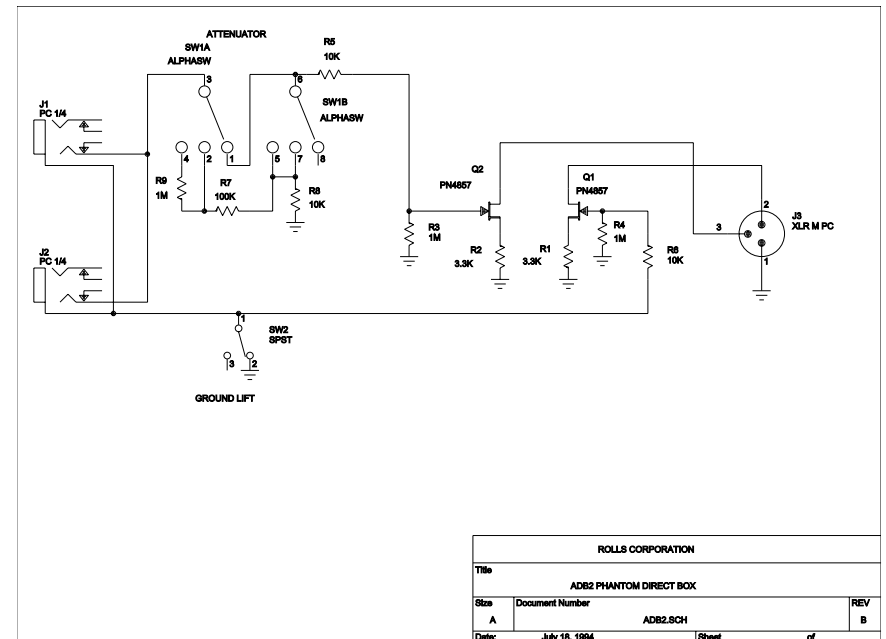

ROLLS CORPORATION			
Title	ADB2 PHANTOM DIRECT BOX		
Size	Document Number	ADB2.SCH	REV
A			B
Date:	July 18, 1994	Sheet	of