



Quam

SSB-2

SPEAKER SUPPORT BRIDGE

For 8" O.D. Loudspeaker Assemblies

GENERAL DESCRIPTION

The **SSB-2** is a rust resistant steel, load bearing support for round or square loudspeaker assemblies in a drop-tile ceiling grid. Easy "mark & cut" "square" hole design for fast and efficient installation. Multiple seismic tie-off points are provided. Tinnerman clips provide easy screw threading, quick mount tabs hold the back box in place without screws, and locating tabs provide secure mounting positions in ceiling tiles.

INTENDED USE - Indoor Environment

Installation	Parallel to floor plane in a suspended ceiling structure; maximum span of 24" in one dimension.
---------------------	---

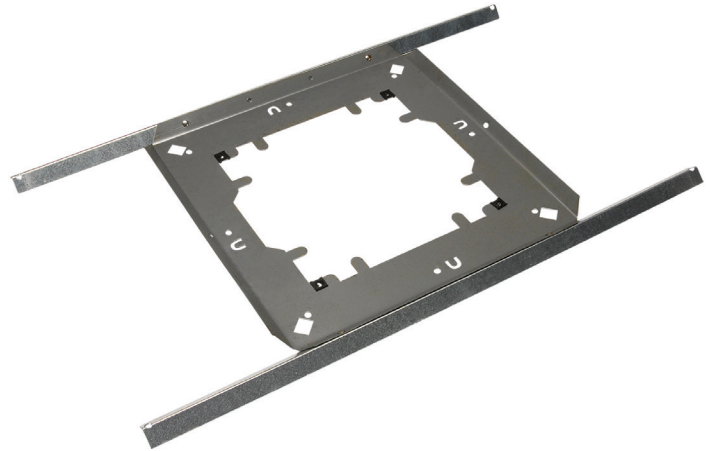

RECOMMENDED QUAM COMPONENTS

Baffles	BR8VP, BR8W, BR8WS, BS8VP, BS8W, and BS8WS
Enclosures	ERD-8, ER8DU

