

Esfera

SPM 8000

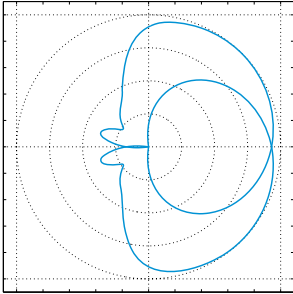

Instruction manual

A

— 0.0

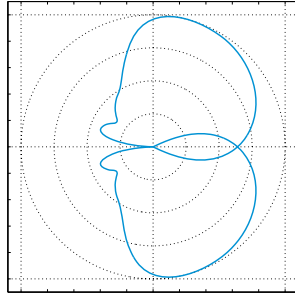

— 0.5

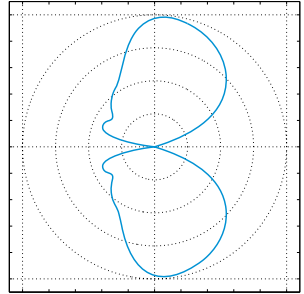

— 1.0

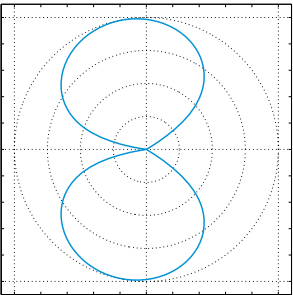
B

— 0.0

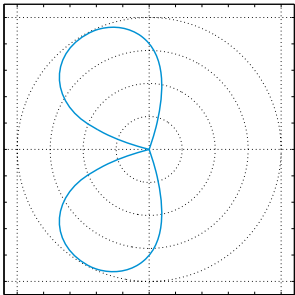

— 0.4

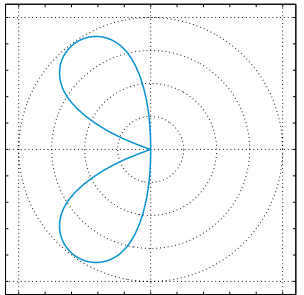

— 1.0

C

Input [dBFS]

- Compressor Ratio = 1
- Compressor Ratio = 2
- Compressor Ratio = 4

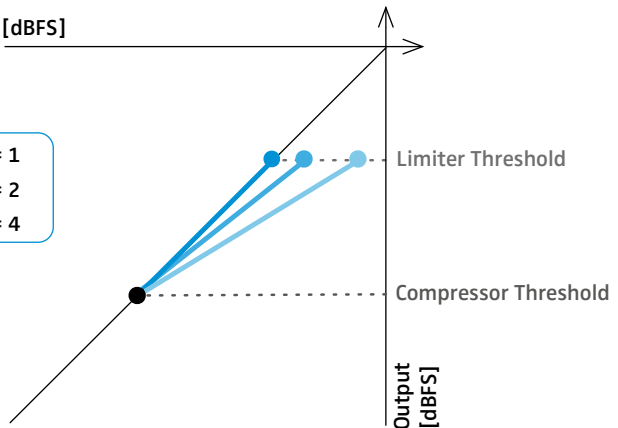

Output [dBFS]

The Esfera surround microphone system

Esfera is a surround microphone system which is easy to install and very easy to use. Esfera provides 5.1 surround sound from just two channels, making complicated surround mic installations a thing of the past. The system consists of the SPM 8000 stereo microphone – supplied complete with basket windshield, suspension with pistol grip, “hairy” cover and cable – and the SPB 8000 central unit that converts the signals of the microphones into a complete 5.1 audio signal.

The SPM 8000 stereo microphone

Two RF condenser microphone capsules in XY configuration are at the core of the SPM 8000 stereo microphone. When used in conjunction with the SPB 8000 central units, the two microphones can create a complete 5.1-channel surround sound effect. The microphone is supplied complete with basket windshield, suspension with pistol grip, “hairy” cover and stereo cable (XLR-5 to 2x XLR-3).

- Can be used as a high-quality stereo microphone or – with the SPB 8000 – as a compact 5.1 microphone
- Very natural, detailed sound
- Weather-proof and rugged
- Exceptionally low inherent self-noise prevents masking of delicate sound structures
- Symmetrical transducer technology ensures extremely low distortion
- Transformerless and fully floating balanced microphone outputs: no coupling of spurious signals
- High output signal voltage ensures interference-free signal paths
- Supplied complete with basket windshield, suspension with pistol grip, “hairy” cover and stereo cable (XLR-5 to 2x XLR-3)

Package contents

- 1 SPM 8000 stereo microphone, consisting of 2 microphone capsules and a suspension with pistol grip
- 1 basket windshield
- 1 “hairy” cover
- 1 Y-adapter cable (XLR-5 socket to 2x XLR-3 connector)
- 1 instruction manual

Product overview

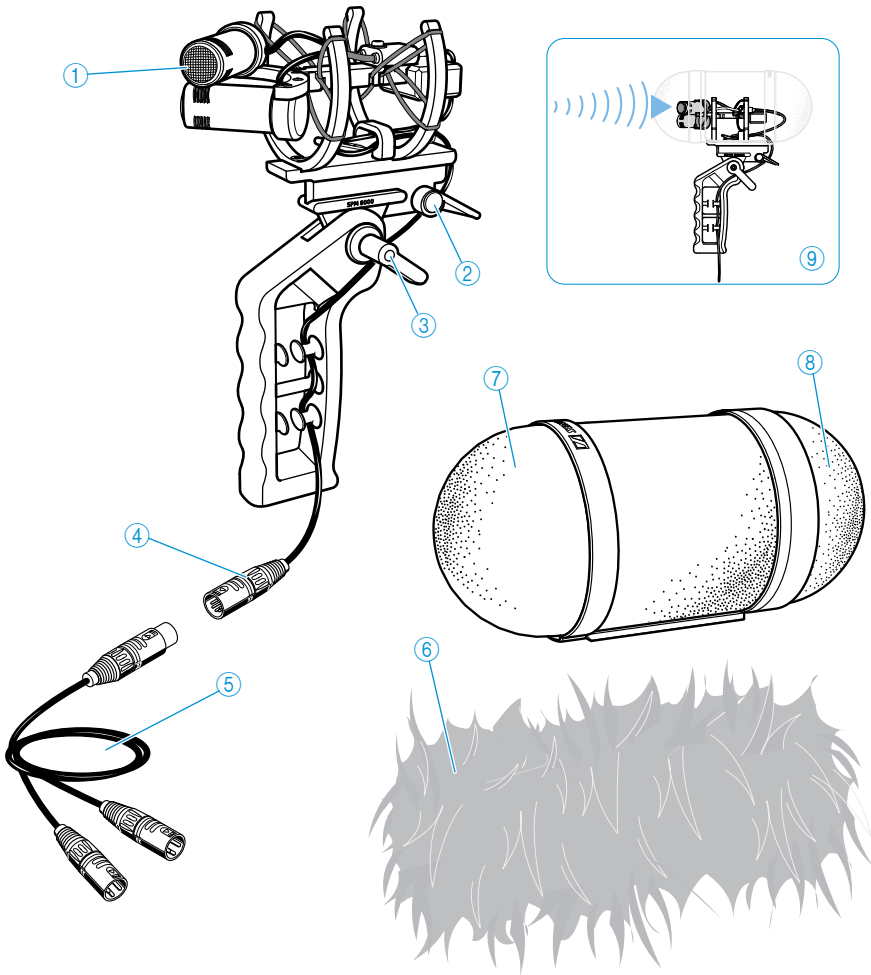

- ① SPM 8000 stereo microphone
- ② Locking lever for windshield
- ③ Locking lever for adjusting the inclination
- ④ XLR-5 connector
- ⑤ Y-adapter cable
XLR-5 socket to 2x XLR-3 connector
red connector: right channel
yellow connector: left channel
- ⑥ "Hairy" cover
attenuation of wind noise: approx. 30 dB
- ⑦ Basket windshield, front basket
- ⑧ Basket windshield, rear basket
- ⑨ Pick-up direction

Putting the SPM 8000 into operation

The SPM 8000 is shipped with a transport safety device.

- ▶ Loosen the transport safety device **before** putting the SPM 8000 into operation (see diagram).

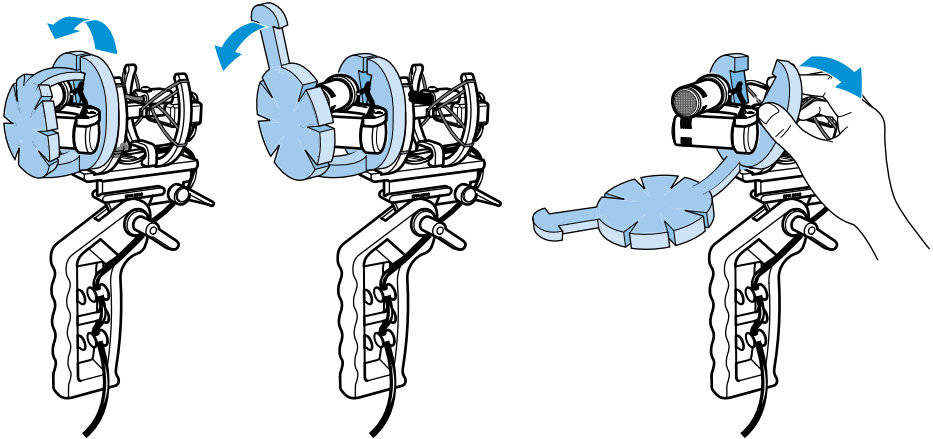

Removing and attaching the windshield

- i** The windshield changes the sound only slightly, but – in combination with the “hairy cover” – attenuates wind noise by approx. 30 dB.

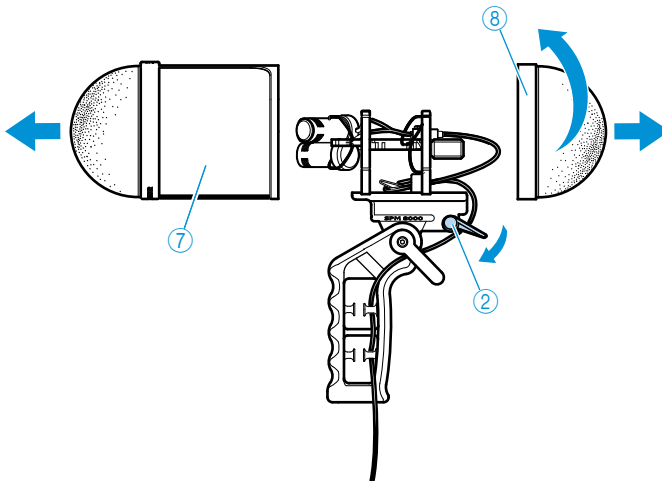

To remove the basket windshield:

- ▶ Remove the “hairy” cover ⑥ by unfastening its snap fasteners and pulling it away from the windshield.
- ▶ Unscrew the rear part ⑧ of the windshield by turning it counter-clockwise.
- ▶ Loosen the locking lever ② by pushing it down.
- ▶ Remove the front part ⑦ of the windshield by pulling it away from the suspension/pistol grip.

To attach the basket windshield:

- ▶ Make sure that the microphone cable is guided correctly (see diagram on page 3).
- ▶ Slide the front part ⑦ of the windshield over the shock-mount.
- ▶ Screw the rear part ⑧ of the windshield to the front part of the windshield by turning it clock-wise.
- ▶ Lock the windshield by pushing the locking lever ② up.
- ▶ Replace the “hairy” cover ⑥ by sliding it over the basket windshield and fastening its snap fasteners.

Inclining the SPM 8000

- ▶ Loosen the locking lever ③, adjust the desired angle and tighten the locking lever ③ again.

Connecting the SPM 8000 to the SPB 8000/to audio devices

Connection data of the SPM 8000:

- 48 V \pm 4 V phantom power (P48, IEC 61938)
- XLR-5 connector or
- 2x XLR-3 connector via Y-adapter cable

To connect the SPM 8000 to a camera/audio device with **XLR-5 input**:

- ▶ Connect the XLR-5 connector ④ of the SPM 8000 to the camera or audio device.

To connect the SPM 8000 to the SPB 8000 central unit or to an audio device with 2 analog **XLR-3 inputs**:

- ▶ Connect the XLR-5 connector ④ of the SPM 8000 to the Y-adapter cable ⑤ (supplied).
- ▶ Connect the two XLR-3 connectors of the Y-adapter cable ⑤ (red = right channel, yellow = left channel) to the inputs of the SPB 8000 central unit or of the audio device. The inputs of the central unit are also marked red and yellow.



If you want to use the SPM 8000 digitally, you have to use an A/D converter.

Cleaning and maintaining the SPM 8000

CAUTION

Damage to the product due to liquids!

Liquids can damage the electronics of the product!

Liquids entering the product can cause a short-circuit and damage the electronics.

- ▶ Keep all liquids away from the product.
 - ▶ Do not use any cleansing agents or solvents.
-
- ▶ Before cleaning, disconnect the product from audio devices connected to the mains power supply.
 - ▶ Only use a soft, slightly damp cloth to clean the product.

Cleaning the basket windshield

- ▶ Remove the windshield as described on page 4.
- ▶ Use a slightly damp cloth to clean the windshield from the inside and outside or scrub with a brush and rinse with clear water.
- ▶ Dry the windshield.
- ▶ Attach the windshield as described on page 4.

Specifications

Pick-up pattern	cardioid (XY-stereo, 90° offset)
Frequency response	35 Hz to 20 kHz
Sensitivity	-34 dBV/Pa (20 mV/Pa)
Max. sound pressure level	142 dB SPL
Equivalent noise level	13 dB(A) (DIN-IEC 651) 22 dB (CCIR 268-3)
Phantom power	48 V ± 4 V (P48, IEC 61938)
Current consumption	3.3 mA
Diameter	approx. 106 mm
Length	approx. 237 mm
Weight	approx. 595 g (670 g with "hairy" cover)

Operating conditions

Ambient temperature	0 °C to +45 °C
Relative humidity	max. 85 % at 40 °C (non-condensing)

Storage and transport conditions

Ambient temperature	-10 °C to +70 °C
Relative humidity	max. 95 % at 40 °C

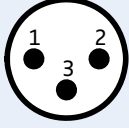

Connector assignment

XLR-5 connector	Assignment
	Pin 1: ground Pin 2: left+ Pin 3: left- Pin 4: right+ Pin 5: right-

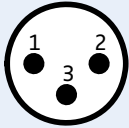
XLR-3 connector (yellow)	Assignment
	Pin 1: ground Pin 2: left+ Pin 3: left-

XLR-3 connector (red)	Assignment
	Pin 1: ground Pin 2: right+ Pin 3: right-

In compliance with

Europe	 EMC: EN 55103-1/-2 Safety: EN 60065
USA	FCC 47 CFR 15 subpart B
Canada	Industry Canada ICES_003
China	
Australia/ New Zealand	

Polar diagram

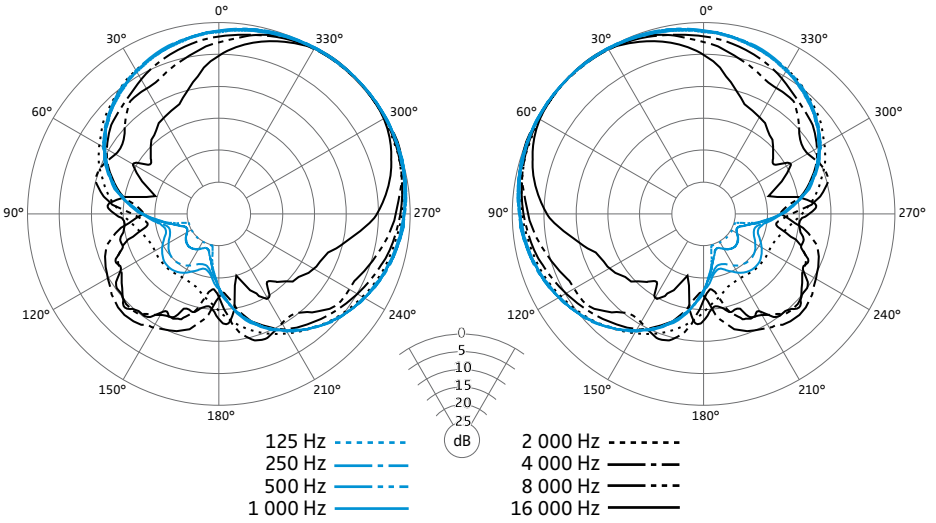

Frequency response curve

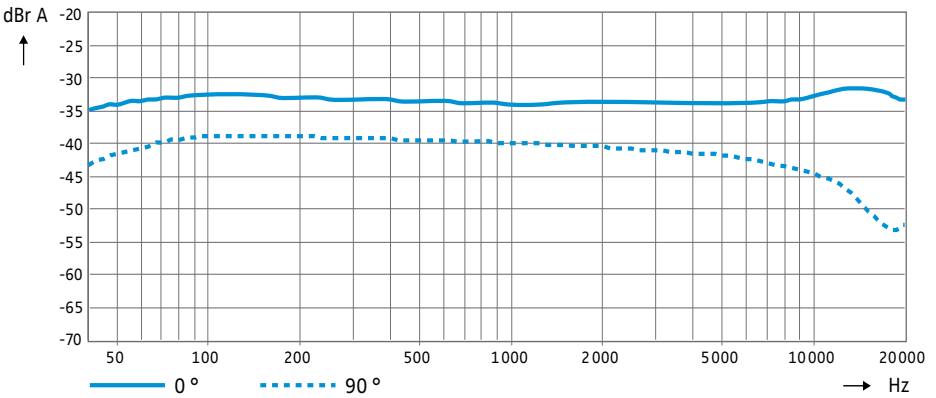

Manufacturer Declarations

Warranty

Sennheiser electronic GmbH & Co. KG gives a warranty of 24 months on this product.

For the current warranty conditions, please visit our website at www.sennheiser.com or contact your Sennheiser partner.

In compliance with the following requirements

- WEEE Directive (2012/19/EU)
Please dispose of these products by taking them to your local collection point or recycling center for such equipment.



CE Declaration of Conformity

- RoHS Directive (2011/65/EU)
- EMC Directive (2014/30/UE)

The declaration is available at www.sennheiser.com.

Before putting the product into operation, please observe the respective country-specific regulations.



Sennheiser electronic GmbH & Co. KG

Am Labor 1, 30900 Wedemark, Germany
www.sennheiser.com

Publ. 06/13, A01