

DA-60_{MKII} PRELIMINARY

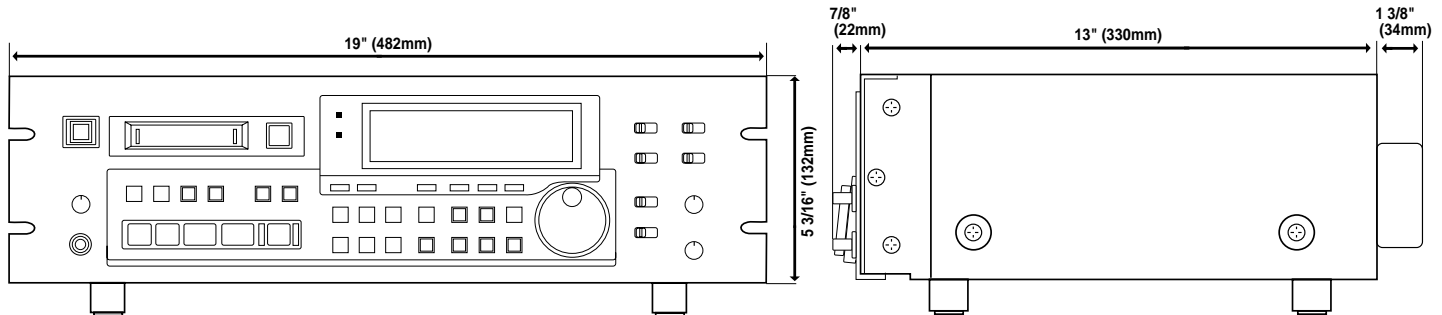

The DAT for production and post-production

What do you look for in a production-quality DAT? Great sound? Transfer convenience? Editing capabilities? Synchronization? 4-Heads with confidence monitoring? More? Until now, the price for a DAT recorder of this caliber has been out of reach except to those studios with unlimited budgets! No more! TASCAM delivers these features and more with the DA-60_{MKII} production-quality 4-head synchronizable DAT. All at a price your studio can afford.

The DA-60_{MKII} is a synchronizable 4-head DAT powerhouse that's perfect for both production and post-production environments. It delivers superior sound quality, full-featured functionality and durability that studio pros expect from TASCAM.

Rugged TASCAM Construction

Combining pristine sound and superior engineering, the DA-60_{MKII}'s rugged construction, intuitive design and rock-solid reliability are all encased in its tempered metal 19" 3U rack case. There you'll find a read/write system comprised of 4 independent direct drive motors, an auto-calibrating 4-head drum and the best sounding, state-of-the-art A/D and D/A converters available anywhere. Even more important, the DA-60_{MKII} features help you maintain a periodic maintenance schedule thanks to a Time Spun indicator which gives you an instant readout of your DA-60_{MKII}'s total head operating time.

Versatility and Features Mean the Best DAT Performance

The DA-60_{MKII} delivers transparent, natural sounding audio recordings and reproductions. It produces up to 94dB of clear, quality audio employing 64 times oversampling 1 bit Delta-Sigma A/D conversion with an incredibly wide 5Hz ~ 22kHz frequency range. Signal-to-noise ratio is an amazing 94dB, and wow and flutter is virtually unmeasurable. At the output stage, the DA-60_{MKII} uses 8 times oversampling 20 bit Sign-Magnitude D/A conversion which virtually eliminates zero-cross distortion. And because program material is captured digitally, the physical imperfections of tape and their effect on sound quality are negligible. The result is the best sounding DAT available anywhere! The DA-60_{MKII} operates at two primary sampling rates: 44.1kHz (the CD reference standard) and 48kHz when the highest-quality audio for post-production is your goal. Of course with a DAT recorder of this caliber, standard pull up and pull down rates of 44.056kHz, 44.144kHz, 47.952kHz and 48.048kHz are fully supported.

And audio reproduction is of remarkably high quality, even when the $\pm 12\%$ varispeed function is used to slow or speed the transport.

The DA-60_{MKII} shines at preparing master tapes for mass CD production and delivers frame-accurate film/video scoring for post production. It's easy to enter start IDs for each track, renumber the tracks, post-stripe timecode or place professional sounding fade in/outs to your program material through the intuitive, easy-to-understand feature menus of the recorder's full-function LED control panel.

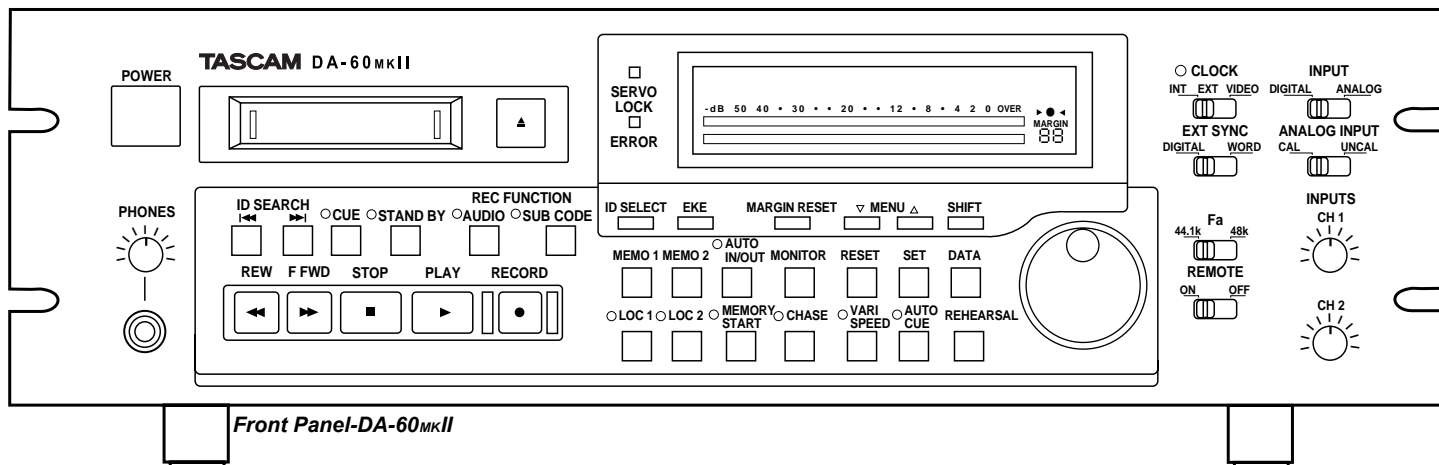

Front Panel-DA-60mkII

Perfectly Synchronized Audio/Visual Soundtracks

The DA-60mkII has a highly accurate digital clock, and its clock source is switchable to meet your synchronization needs. For working with DAWs, you'll find WORD CLOCK IN, OUT and THRU, and when doing sound for picture, the unit's VIDEO sync port will keep you right where you need to be!

The TASCAM DA-60mkII also supports IEC958 Type II data input more commonly recognized as S/PDIF. This enables the DA-60mkII to digitally communicate with most consumer level DATs, CDs and other equipment. All this means the DA-60mkII gives you the freedom to interact with just about any digital audio product imaginable.

In a "sound for picture" environment, the DA-60mkII accepts Video Sync from an external source and resolves to picture. Additionally, the DA-60mkII fully supports Sony P2 protocol and

will behave like a common VTR to video editors and other system controllers. Also known as Sony 9-Pin, this capability enables the DA-60mkII to integrate seamlessly into any post-production environment.

Command Control for Audio and Subcode Data

The DA-60mkII features an intuitive, highly informative LED panel that gives users complete control over all production functions. Stereo peak hold meters ensure that you're capturing proper signal levels. MARGIN readings display "headroom" in dB increments up to 39 — between your highest peaks and the onset of digital saturation. Twin timecode indicators constantly update SMPTE position for both external and internal TC in a master/slave, multiple machine environment.

What's more, it's easy to reveal programmable parameter values for selected menu items including Copy ID, memo point capture and trim, and auto cue sensitivity levels. Plus, you can capture

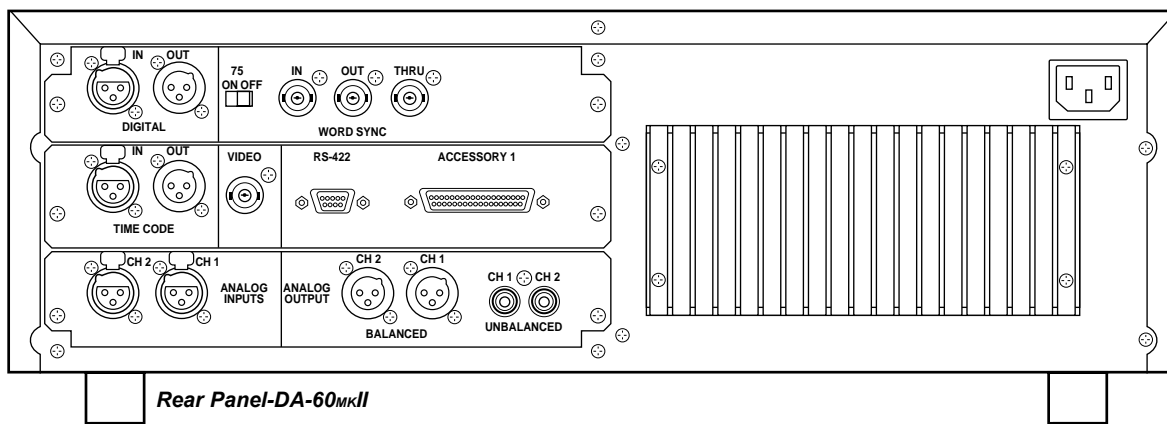

Rear Panel-DA-60mkII

offsets, jam sync while generating timecode for smooth, continuous SMPTE under non-contiguous conditions, or adjust cross-fade time to accommodate smooth punch-ins – all with remarkable ease. Users will appreciate the DA-60MKII's rotary data wheel. It makes editing offsets or memory start points quick and effortless. And, each function has its own corresponding menu display or LED indicator light, so you're sure to know the status of the DA-60MKII at a glance. Once you've configured the machine to your liking, a unique memory feature lets you save up to three different setups (snapshots) which can be recalled at any time with a few simple keystrokes.

Dual Autolocation Makes Editing Foolproof

The DA-60MKII offers three ways to navigate through your tapes to find editing points for punch-ins, overdubs and other post-production tasks. The simplest is using the ID Search button to locate to the exact beginning of the next/previous program selection. And, to mark a tape position during a program, you can capture locate points on the fly by pressing the MEMO key. Or, if you wish to trim that position or directly enter a known timecode address, simply enter the location using the DA-60MKII's H: M: S: F display and the rotary data wheel.

Confidence Monitoring & Instant Playback for Those Tight Cues

If confidence monitoring is critical to your work, then a 4-head DAT like the DA-60MKII is your only choice. With the DA-60MKII, a single keystroke toggles you between Source and Tape, giving you peace of mind as you record — no more guessing about what you "think" you're hearing.

Additionally, the DA-60MKII provides a pair of special cueing and playback features — Auto Cue and Memory Start. They combine to provide instant playback from exact points, without any mechanical delay caused by bringing tape up to speed or realignment of playback heads. With Auto Cue, you can cue to the "first frame of audio". Auto Cue is programmable with four sensitivity levels to accommodate varying types of program material.

Using the DA-60MKII's 3-second RAM buffer, Memory Start provides for instant starts of program material. Used in conjunction with the recorder's MEMO points, the Memory Start function can be trimmed over a range of 30 frames, enabling you to position the start of material with frame accurate precision. There's even a REHEARSAL function that lets you audition the contents of the RAM buffer.

Accepts Digital or Analog Input

Integrating the TASCAM DA-60MKII into your facility couldn't be easier. A quick look at the rear panel reveals easily accessible XLR connectors for incoming digital or balanced analog sources. And, to make reference copies of your master tapes, the DA-60MKII is equipped with both balanced XLR and unbalanced RCA analog outputs.

Rock Solid, No Nonsense Built-in Synchronization

The DA-60MKII's internal clock, combined with its Video and Word Clock capabilities enable the recorder to synchronize with other equipment under virtually any condition you might encounter. Code-only Master? No problem. Just feed timecode and hit CHASE. Sony P2 under control from a video editor? Absolutely! Just feed house (video) sync to the DA-60MKII's Video sync port for clock reference and connect a standard 9-Pin D-Sub connector cable to the RS-422 port and you're ready to make that next great video epic. Digitally transfer audio to or from a DAW? Of course! Run your Word Clock cable for clock reference, and some XLR equipped cables for timecode and digital I/O and you're ready. You'll also find an Accessory 1 port for basic control from non RS-422 equipped controllers.

No matter what type of work you do, you'll appreciate the DA-60MKII's flexibility and its rapid response transport mechanism. Together, they take the hassles out of synchronization. You'll be able to easily set up pinpoint-perfect orchestra hits, sound effect overdubs and other post-production audio magic.

A Quick Review Of The DA-60mkII

- Uses DAT tapes for reliable, compact archival and pristine digital audio
- Audio and Sub Code Record Function switches let you pre or post stripe TC and edit other subcode area parameters
- Find the start of the next/previous track with one-touch ease
- 4-head confidence monitoring
- Intuitive basic recorder controls
- Twin MEMO and LOCate keys let you mark critical tape points for a variety of edit operations
- MEMORY START function with REHEARSAL stores 3 seconds of playback audio for seamless, on-the-fly starts, great for tight cues!
- Full support for Sony P2 protocol — DA-60mkII behaves like a common VTR under editor control
- Video and Word Clock ports for integration with video systems or DAWs
- CAL and UNCAL positions on front panel accommodate virtually any input signal
- Supports both AES/EBU digital I/O & S/PDIF digital input
- Balanced XLR analog inputs and outputs — RCA unbalanced outputs
- Phones jack and level control

Feature-Filled LED Command Control Center

- Display window has a separate lighted indicator for every editable feature: synchronization, subcode editing, tape/program location and more
- Dual peak hold stereo LED meters and MARGIN readings give quality-conscious engineers constant visual information on tape saturation levels
- Rotary data wheel provides fine-tuning control over numerous parameters such as MEMO point trim with visual displays confirmed in the LED Menu area
- Timecode readouts in either ABSolute or SMPTE formats includes Auto function where SMPTE is automatically displayed if present on tape

Optional RC-D6 Remote Control Unit

Your mastering deck is a major part of your recording process, but not the only part. Controlling the DA-60mkII from elsewhere in the studio, such as the mixing console, can be very convenient. The RC-D6 provides basic controls and freedom of movement in a compact form factor. The front panel of the RC-D6 Remote Controller has the same transport buttons as the DA-60mkII so you can control recording, cueing, punch in/out and rehearsal, and ID Search from practically anywhere in the room. Simply connect the RC-D6 Remote Controller to the DA-60mkII with a 15-foot cable and plug it into the rear panel ACCESSORY 1 port.

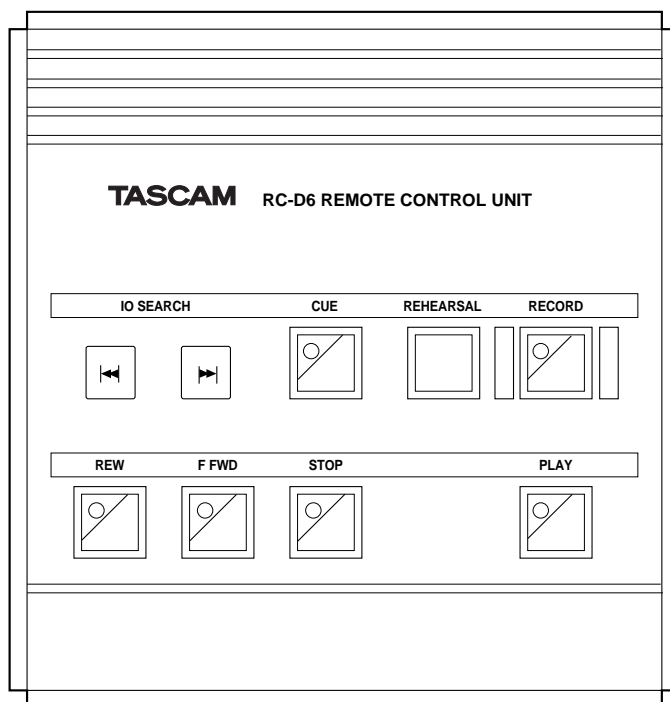

Remote Control-DA-60mkII

SPECIFICATIONS

Type:	Rotary Head Digital Audio Tape Recorder
Tape Speed:	8.15 mm/sec, (12.225 mm/sec.)
Quantization Bit:	16-bit linear
Sampling Rate:	48 kHz, in record (digital or analog)/play 44.1 kHz, in record (digital or analog)/play
Frequency Response (Record/play):	5 - 22,000 Hz \pm 0.5 dB
Signal to Noise Ratio:	Better than 94 dB
Dynamic Range:	Better than 94 dB
Total Harmonic Distortion (THD):	0.004% or less (at 1 kHz, max. input before OVER lights)
Channel Separation:	Better than 90 dB
Wow and Flutter:	Unmeasurable (less than \pm 0.001%)

INPUT/OUTPUT

Analog

Line In:	
Connector:	XLR -3-31 (x2)
Nominal Input Level:	+4 dBm
Input Impedance:	20 kohms, balanced
Line Out:	
Connector:	XLR -3-32 (x2)
Nominal Output Level:	+4 dBm
Output Impedance:	10 ohms, balanced
Monitor Out:	
Connector:	RCA jack (x2)
Nominal Output Level:	-10 dBV
Output Impedance:	1 kohms, unbalanced
Headphone Out:	
Connector:	1/4" jack (x1)
Output Level:	100 mW or more (8-ohm load)

Digital

Input	
Connector:	XLR -3-31 (x2)
Format:	IEC958, TYPE I (AES/EBU)/TYPE II auto switched
Output:	
Connector:	XLR-3-32 (x1)
Format:	IEC958, TYPE I (AES/EBU)

Word Sync

Input:	
Connector:	BNC
Nominal Input Level:	Equivalent to TTL
Input Impedance:	75 ohms, unbalanced

Output:	
Connector:	BNC
Nominal Output Level:	Equivalent to TTL
Output Impedance:	75 ohms, unbalanced

Thru:

Connector:	BNC
Nominal Output Level:	Equivalent to TTL
Output impedance:	75 ohms, unbalanced

Time Code (when SY-D6 installed)

Input	
Connector:	XLR-3-31 (x1)
Input Level:	2Vp-p
Input Impedance:	10 kohms, balanced

Output

Connector:	XLR-3-32 (x1)
Output Level:	2Vp-p
Output Impedance:	75 ohms, balanced

Control I/O Port

Parallel	
Connector:	37-pin D-sub
Input/Output Level:	Equivalent to TTL

Serial (when SY-D6 installed)

Connector:	9-pin D-sub
Protocol:	RS-422

Power Requirements

USA/Canada:	120 V AC, 60 Hz
UK/Australia:	240 V AC, 50 Hz
Europe:	230 V AC, 50 Hz
General Export Model:	120/230/240 V AC, 50/50 Hz, switchable

Power Consumption:	58 W
Weight:	11.5 kg

Specifications and features subject to change without notice or obligation.



For more information about other TASCAM FAXBACK literature, call 1-800-827-2268.

TASCAM®

Take advantage of our experience.