

**N/DYM SERIES WIRELESS  
USER GUIDE  
GEBRAUCHSANWEISUNG  
MODE D'EMPLOI  
INSTRUCCIONES DEL USUARIO**

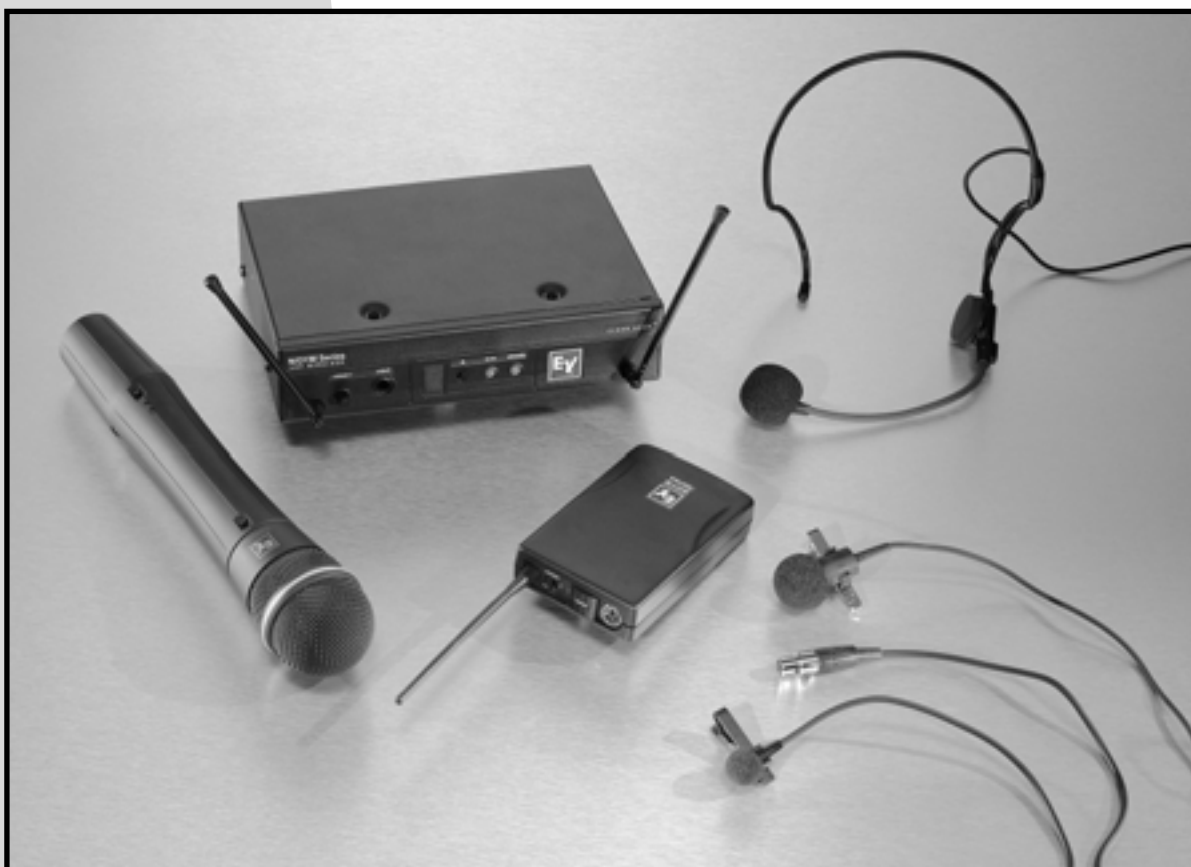

**WIRELESS  
MICROPHONE  
SYSTEM**



**D R A H T -  
L O S E S  
M I K R O F O N -  
S Y S T E M**

**S Y S T E M E D E  
M I C R O P H O N E  
S A N S F I L**

**S I S T E M A D E  
M I C R Ó F O N O  
I N A L Á M B R I C O**

1. Quick System setup guide
2. System Description
3. Detailed system/component setup instructions
  - 3.1 Receiver Setup & Operation
  - 3.2 Handheld Transmitter Setup
  - 3.3 Beltpack Setup
4. Guidelines/Recommendations for best performance
5. Troubleshooting Guide
6. Technical Specifications
7. Certifications
8. Components & Accessories
9. Service/Warranty

## 1. Quick System Setup Guide

### Receiver Setup

1. Plug power supply cord into the back of the receiver and plug the power supply into an outlet. The channel display & red/green "Diversity" light on the receiver front panel should light up.
2. Depress "SET" button on front panel and release when channel display starts to flash (about 3 seconds). This activates "ClearScan™" to find an interference free channel for operation. Note the channel (0 - 9) shown on the receiver front panel channel display.
3. Connect receiver audio output to mixer (or amplifier if using guitar system). Mute or reduce mixer/amp gain.
4. Orient receiver antennas angled up and away from each other (at a 90 degree angle).

### Transmitter Setup

1. Open battery compartment, install 9 Volt battery. Make sure to observe proper battery polarity.
2. Adjust channel setting to match channel number shown on receiver channel display. Replace battery cover.
3. If using beltpack transmitter, plug the microphone into the transmitter connector. If using guitar system, connect 1/4" plug into guitar.

### Operating the system

1. Turn transmitter ON via the ON/OFF switch. Yellow "Tx On" light should illuminate on the receiver front panel.
2. Turn audio switch to the ON position to unmute the audio.
3. Set mixer/amp gain to normal position.
4. Talk/sing into the microphone or play the guitar at a normal volume. You should hear audio coming out of the system.
5. If the signal is distorted, turn the **gain adjust** control on the transmitter down. If the signal level is low, you may need to turn the **gain adjust** control up.
6. If connected to the receiver 1/4" output jack on the front panel, adjust gain (via the control next to the connector) to correspond to the signal level found when singing or playing through a wired system.

## 2. System Description

The Electro-Voice N/DYM Wireless is a series of 10 channel frequency agile UHF wireless systems that combine EV's legendary quality and reliability with high value. The N/DYM Series transmitters and receivers operate in the UHF frequency range on one of ten channels between 800 and 814 MHz. The well-designed audio circuitry ensures excellent signal-to-noise ratio with accurate sound quality.

### System Features

- 10 Channel Frequency Agile UHF system operation.
- Featuring "ClearScan™" which makes for quick and easy system setup.
- Handheld transmitters feature EVs' N/DYM mic elements, for superior sound quality.
- True-diversity system with Secure-Phase™ ensures maximum range and freedom from interference.
- Well-designed companding and audio circuitry insures high signal-to-noise ratio and excellent sound quality.
- Choice of two handheld and four bodypack systems, including a system specifically for guitar.
- Permanently attached antennas make setup quick and easy.
- Receivers may be rack-mounted with optional kit.
- Audio output via 3-pin XLR-type balanced mic level and 1/4-inch unbalanced line level connectors.

## 3 Detailed Setup Instructions

### 3.1 Receiver Setup & Operation

1. Place the receiver where there is a clear line of sight to the area where the transmitter will be used. Rotate the receiver's antennas and separate them 90 degrees (see Figure 1).
2. Connect the power supply cord to the receiver. Plug the power supply into an AC outlet. Confirm that the receiver is ON by checking for the lit red/green **Diversity** light and **channel display** on the front panel.  
**NOTE:** Upon power-up, the receiver will return to the channel it was set to when it was turned off.  
**CAUTION: Please make sure that the AC adapter is the correct voltage for your local requirements.**
- 3 **ClearScan™:** The N/DYM Wireless system features ClearScan™. ClearScan™ automates the process of finding a clear channel to use in setup of your N/DYM Wireless system. To use ClearScan™, depress and hold down the **set** button for 3 seconds. When the channel display begins flashing release the **set** button. The receiver is now searching for a clear frequency, by measuring the RF energy present on each channel. The entire process will take about 5 seconds.

While scanning, the channel display will show the channel number being scanned. When ClearScan™ is complete, the display will stop flashing and it will display the number of the channel recommended for use.

**NOTE:** If using more than one N/DYM system, set up ONE system at a time. Turn on the transmitter for the first system, before using ClearScan™ to set up the second. Please see the "Guideline/Recommendations for best performance" section to setup more than two systems.

4. **Setting the channel.** Changing the channel on the receiver can also be done manually. By momentarily depressing the Set button, the channel number is increased by one.

**NOTE:** When the system is turned off, the channel number is saved in non-volatile memory. When the receiver is turned on, it will return to the same channel number.

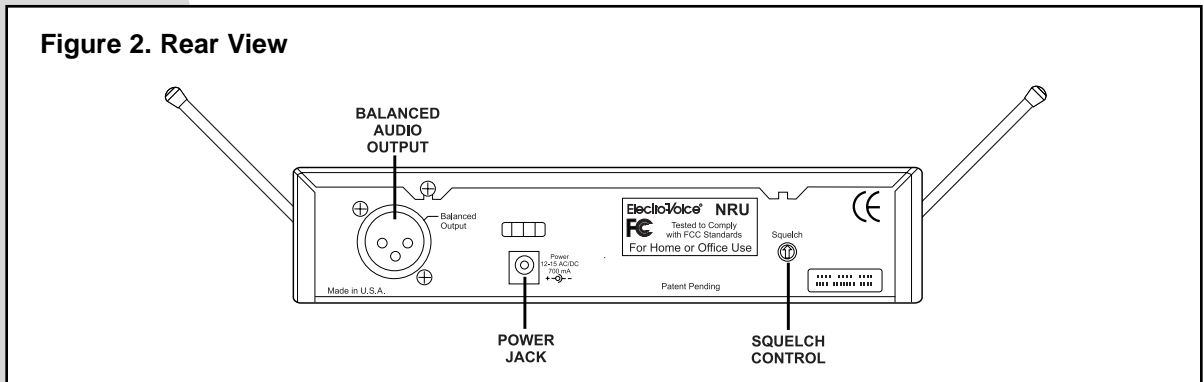
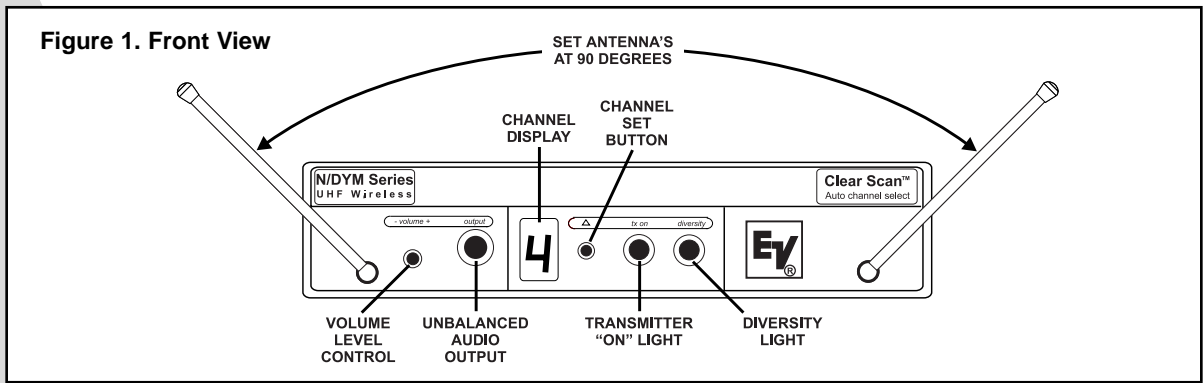

5. **Channel change lock-out.** Once the channel has been set on the receiver, the N/DYM system has the capability to deactivate or lock-out the channel change button. This is done by depressing the **set** button for 10 seconds or more. Lock-out is active when the decimal point illuminates in the lower right corner of the channel display. This will defeat the set button. To override or defeat the lockout function, again depress the set button for 10 seconds. This will reactivate the channel set button to work normally. This function can be useful when the wireless is in a location where unauthorized personnel have access to the receiver.

**NOTE:** If the system is in "lock-out", ClearScan™ will not function.

6. Make sure the gain setting is muted or turned down on the mixer channel or amplifier input you will connect the wireless system to.
7. Plug the audio cable (not supplied) into either output connector.

**NOTE:** The 3-pin XLR-type connector is the preferred choice since the output is balanced. Either connector may be used with good results. If the 1/4-inch connector is being used, turn the volume level control (see Figure 1) on the front panel to the twelve o'clock position (midway in the control's range).

**NOTE:** The 3-pin XLR-type connector output level is fixed, and cannot be adjusted.

**Now refer ahead to details on how to set up the transmitter.**

Once the Transmitter has been set-up, and turned on....

8. Speak into the microphone or play the guitar. Turn up the level on the mixer or preamp until you're able to hear the desired signal.

**NOTE:** If using the 1/4" jack output, it may be necessary to adjust the receiver's output until the volume level from the wireless system approximates the level of an equivalent wired microphone or instrument.

9. "Walk" the expected area of use to check for dropouts or interference. If problems occur, see the troubleshooting section.
10. **Adjust the squelch control if necessary.** The squelch control on the back of the receiver may be adjusted to effectively increase range or to reduce interference. The factory setting is at a midpoint, which should be suitable for most situations. To effectively increase range, turn the control counter-clockwise until you hear noise or interference. Then, turn the squelch clockwise until the noise is muted. To reduce interference, turn the control clockwise.

**NOTE:** If the squelch is being adjusted, the transmitter should be turned off.

**Caution! Increasing the range will make the system more susceptible to outside interference! Reducing interference will also effectively decrease the range, which will make the system more susceptible to dropouts.**

**3.2 Handheld Transmitter Setup**

1. **Insert battery.** Slide open the hinged battery compartment cover by placing your thumb on the indents of the battery door (at the bottom of the transmitter) and gently pushing down (see Figure 3). Insert the battery, terminal end first, into the compartment, with the smaller positive terminal to the right.

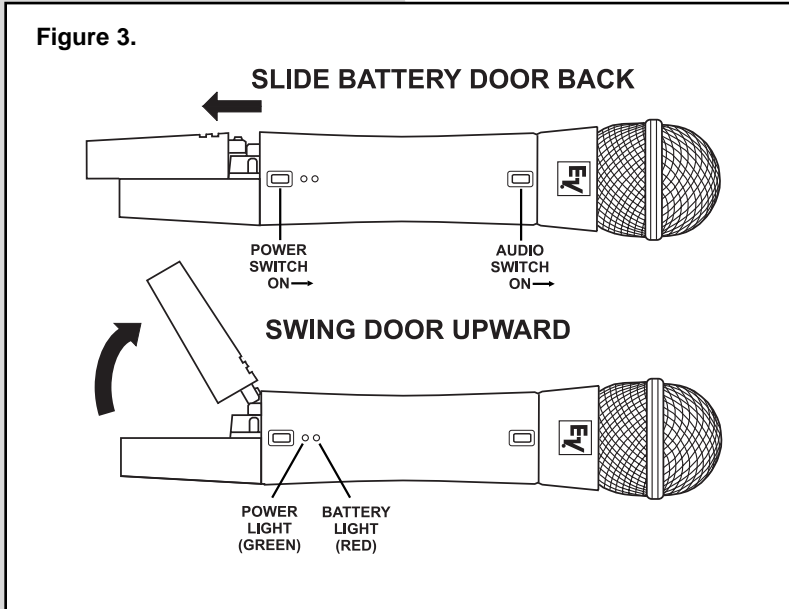

2. **Set handheld transmitter channel** to match the channel setting on the receiver (channel number displayed on front of receiver panel). The channel setting on the handheld transmitter is accessed through the round opening on the side of the mic housing. Numbers 0 - 9 are printed around the opening. The channel setting is determined by which number the arrowed slot is pointing to. Use a small screwdriver (supplied) to change the channel setting. See Figure 4.
3. **Turn on the transmitter** by sliding the power switch (closest to the battery compartment) forward to the ON position (toward the windscreen). The red battery condition light should flash once and then go out. If the red light stays on or illuminates during a performance, the battery should be replaced immediately. The green light will stay lit when the handheld transmitter is on.
 

**NOTE:** Remember to turn the transmitter OFF when not in use. This will conserve battery life.
4. **Verify reception.** When the transmitter is turned on, the yellow "Tx On" light, located on the front panel of the receiver, will illuminate, indicating that the receiver is picking up the signal. If this does not happen, make sure that the transmitter and receiver are set to the same channels.

5. **Unmute the audio** by sliding the audio switch (immediately below the mic element) towards the windscreen. Speak or sing into the microphone and you should hear your voice through the PA / sound system.
6. **Adjustment of the transmitter audio gain - if necessary.** The transmitter audio gain is set to a mid level which should be suitable for most situations. However, for loud or soft speakers or singers, an adjustment may be necessary. First, speak or sing into the microphone and listen closely. If the gain is too high, you will hear distortion, and if the gain is too low, the signal will be low. In either situation, an adjustment may be necessary.

To adjust the transmitter gain, gently insert the provided screwdriver (or other 3/32-in. screwdriver) into the hole near the head of the transmitter (see Figure 4). Turn lightly until the screwdriver tip drops into the slot in the level control. Gently turn counter-clockwise until the control stops (the mic output is attenuated but not "off"). Slowly turn the mic-level control up while listening to the audio. If the audio becomes distorted, turn the mic level control down (counter-clockwise) about 1/8 turn.

**NOTE:** Operate with the transmitter audio gain set as high as possible without distortion, for the best signal to noise ratio.

7. **Test performance.** Check to see that the yellow "Tx On" light on the front panel of the receiver is illuminated, an indication that the receiver is picking up the signal. Then, "walk" the intended area of use and make sure that there are no barriers to reception or sources of interference. If problems are encountered, see Troubleshooting Guide.

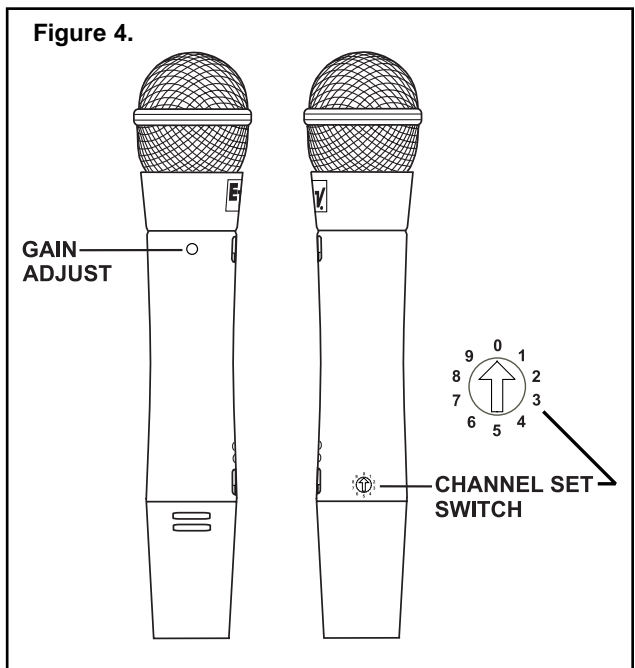

## 3.3 Bodypack Transmitter Setup

1. **Insert battery.** Open the hinged battery compartment by placing your thumb or finger on the indent labeled OPEN on the battery door and pushing down, see Figure 6. When inserting the battery, pay attention to the polarity (+/-) and insert the terminals into the battery compartment first. Close the battery door by sliding the door shut.

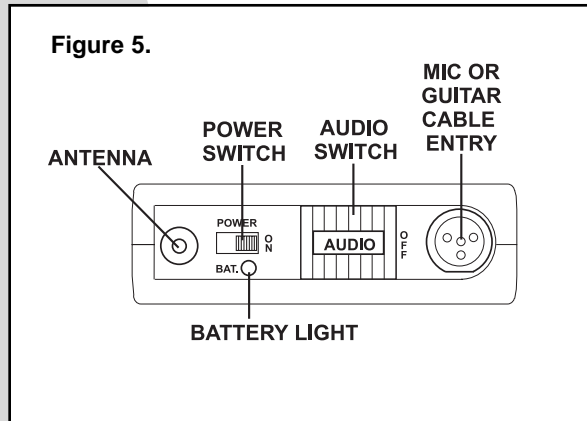

2. **Set the transmitter channel** to match the channel setting on the receiver. The channel switch on the bodypack is located just underneath the battery door, and to the right of the indent labeled OPEN. Note the channel number label (0-9) surrounding the opening. The Bodypack channel must be set to the same number as the receiver channel, which is displayed on the receiver front panel. The channel setting is determined by which number the arrowed slot is pointing to. Use a small screwdriver (supplied) to change the channel setting.
  3. **Turn on the transmitter** by sliding the power switch to its on position. Check the condition of the battery by watching the light below the power switch. The red battery light should flash once and then go out. If the light stays on, the battery is weak and should be replaced.
  4. **Verify** that the transmitter is sending. Observe that the yellow Tx On light on the front panel of the receiver is lit, an indication that the receiver is picking up the signal from the transmitter.
  5. **Connect the audio source.** If using a lavalier or headworn microphone, insert the connector on the end of the mic wire, into the connector on the Bodypack. If using a lavalier mic, use the clip to attach the mic to the users clothing. If using the headworn mic, place the headset on the user's head, positioning the mic at the corner of their mouth. If using a guitar system, connect the 1/4" plug into the instrument.
- NOTE: Keep the audio muted while plugging in and adjusting the microphone or source.** Placement of lavalier and headworn microphones will noticeably change the sound quality, so some testing with the user is necessary. An important point to remember, the closer to the sound source, the stronger or louder the signal.
6. **Unmute the audio**, by sliding the large AUDIO switch located on the Bodypack, to the ON position. Speak or sing into the microphone and you should hear your voice through the PA / sound system.
  7. **Listen carefully to the audio** and be sensitive of overload distortion and low gain.
  8. **Adjust the transmit gain if necessary.** Gently insert the provided screwdriver or other 3/32-in. (2.5 mm) screwdriver into the gain adjustment located at the top edge of the battery compartment under the door. The door has to be opened but not swung upward to make adjustments. Turn lightly until the screwdriver tip drops into the slot on the level control. Gently turn the control counterclockwise until the control stops (the audio output is attenuated but not "off"). Slowly turn the audio level control clockwise while listening to audio; if the audio becomes distorted, turn the mic level control counter-clockwise about 1/8 turn.
  9. **Check reception by** observing that the yellow Tx On light is lit on the receiver's front panel.
  10. **Clip the bodypack to the user's belt, pocket, or guitar strap.** The bodypack can be positioned horizontally or vertically by moving the belt clip attachment. This is done by removing the belt clip attachment screw, rotating the clip to the desired position, and replacing the screw.

**Figure 6.**

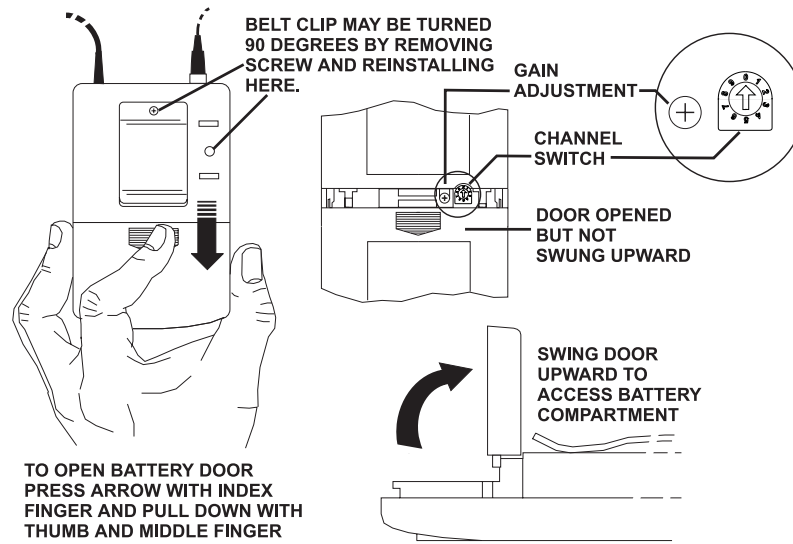

## 4 Guidelines/Recommendations for best performance

### Compatibility

The receiver and transmitter must be set to the same channel to operate together.

### Using Multiple Wireless Systems

If two or more N/DYM Wireless and/or other VHF/UHF wireless systems are being used in the same location, proper frequency coordination is necessary to avoid interference. The following N/DYM System channels will work together:

Channels 0,1,2,3, & 4 or Channel 5,6,7,8, & 9

Contact your dealer or Electro-Voice for assistance, if you are planning to add more wireless systems to be operated simultaneously in the same location.

### Multiple System Setup & ClearScan™

ClearScan™ is most useful for finding operating frequencies for situations where no more than 2 systems will be used simultaneously. When setting up more than 2 systems, use ClearScan™ to choose the first

channel of operation. Set up subsequent systems following the channel groupings listed above in the "Using Multiple Wireless Systems" section.

### Potential Sources of Interference

There are many potential sources of interference for your wireless system. Any electronic product that contains digital circuitry including digital signal processors (reverb/multi-effects units), electronic keyboards, digital lighting controllers, CD players and computers, all emit RF energy that can

adversely affect the performance of your wireless system. It is always best to place your receiver as far away from these devices as possible to minimize this potential source of problems.

### Battery Recommendations

Fresh 9-volt alkaline batteries from a quality manufacturer will yield the best performance from your N/DYM transmitters. Rechargeable 8.4-volt Ni-cad batteries can be used, but will yield much shorter operational time.

When the transmitter switch is turned on, the red battery light will flash once if the battery is good. If

the light does not flash or stays lit continuously, the battery is weak or dead. If the light comes on during use, the battery is weakening and should be replaced as soon as possible.

If sound quality degrades during use, it may be the result of a weakening battery.

### Receiver and Antenna Placement

Do not place the receiver near a large metal object or surface.

Locate the receiver as close as possible to the area where the Transmitter user will be working. Ideally, position the

receiver so that the transmitter is within site of the receiver.

When using multiple systems, do not allow antennas to cross or touch each other.

## 5 Troubleshooting Guide

Problem	Possible Causes	Solutions
No audio & no lights on receiver	Receiver is off	Make sure that power supply is properly connected and providing power to the receiver.
No audio & no Tx ON light on receiver	Transmitter is off.	Turn on transmitter power switch.
	No ( or dead ) battery in transmitter.	Insert fresh battery in transmitter.
	Faulty battery contacts in transmitter.	Clean contacts.
No audio	Transmitter audio switch is off (signal is muted).	Turn on transmitter audio switch.
	Receiver audio cable is damaged or disconnected.	Connect, repair, or replace cable.
	Gain not sufficient on mixer/preamp/amp input.	Increase mixer/preamp/amplifier gain setting.
Low audio signal.	Gain set too low (or muted) on mixer/preamp/amplifier.	Increase gain setting on mixer/preamp/amplifier.
	Receiver audio too low (1/4" output).	Increase receiver audio volume setting.
	Transmitter audio level too low.	Increase transmitter audio gain setting.
Distorted audio signal.	Transmitter audio level too high (overloading transmitter circuit)	Decrease transmitter audio gain setting.
	Receiver audio set too high (1/4" output).	Decrease receiver audio level setting.
	Battery level low in transmitter.	Insert fresh battery in transmitter.
Interference	Another wireless product in the immediate area, operating on the same frequency, or on a frequency that mixes with another RF signal (such as a TV broadcast transmitter).	Change operating frequency. If interference is weak, keep transmitter on at all times (to override interfering signal) whenever receiver is on.
	Receiver placed too close to a digital signal processor or similar device.	Move receiver to a different location.
	Strong electromagnetic field from stage lighting or other source near the transmitter or receiver, which may be producing RF noise on or near the operating frequency.	Change operating frequency. Repair or remove source of interference. Move receiver to a different location.
Short range or drop-outs.	RF reflective metal obstacles between transmitter & receiver.	Move the obstacles, or reposition the receiver.
	Poorly oriented beltpack antenna.	Reorient bodypack so that antenna is positioned vertical (up and down) and facing receiver, if possible.
	Faulty receiving antenna system.	Reposition antennas or receiver.

**6 N/DYM Wireless Series System Technical Specifications**

**UHF Receivers: NRU and NRU-G Receivers**

Receiver Type	Synthesized PLL
Frequency Range (RF)	Between 800 - 814 MHz
Number of Selectable Channels	10
Diversity	True Diversity with Secure-Phase™
RF Sensitivity	< .8 uV for 12 dB SINAD
FCC Data	Approved under part 15
Audio Output,	
Frequency Response	50 – 15 kHz +/- 2 dB
Audio Output, Balanced (XLR)	-20 dBV (600 Ohm Load)
Audio Output, Unbalanced (1/4")	adjustable 8 mv to 0.775V RMS (100 K ohm load)
Distortion	Less than 0.5%
Signal-to-Noise Ratio	>94 dB
Dynamic Range	100 dB

**UHF Transmitters: NBPU, NBPU-G, NHTU-N1, NHTU-N2**

RF Frequency Range	Between 800 - 814 MHz
Number of Selectable Channels	10
Radiated RF Output	10-15 mW typical
Microphone Element NHTU-N1 handheld	EV N/D 167 cardioid N/DYM dynamic
Microphone Element NHTU-N2 handheld	EV N/D 267a cardioid N/DYM dynamic
Standard Bodypack Microphones	
Lavalier: (NRU-L10 system)	EV OLM10 omni-directional condenser
(NRU-L20 system)	EV ULM20 cardioid condenser
Headset: (NRU-H1 system)	EV HM2 cardioid condenser
TA4F Connector Wiring:	Pin 1: Ground; Pin 2: Mic Input; Pin 3: +5 volt bias; Pin 4: +5 volt bias fed through a 3 K ohm resistor for 2-wire electrets
Audio Gain Adjustment Range	40 dB
Battery Life	8 – 10 hours with 9-Volt alkaline
Bodypack Antenna	flexible external 1/4 wave
Handheld Mic Antenna	internal 1/2 wave
Size (Handheld transmitter)	26 cm (10.25 in) long
Size (Bodypack transmitter) HxWxD	4.5 in x 2.6 in x 1.25 in (no antenna) 114 x 66 x 32 mm

## 7 Certifications

### CERTIFICATIONS

**NRU, NRSCU**, Certified to ETS 300 445, Conforms to European Union directives, eligible to bear CE marking.

**NHTU, NBPU**, Certified to I-ETS 300 442 and ETS 300 445, Conforms to European Union directives, eligible to bear CE marking.

**Licensing of Electro-Voice equipment is the user's responsibility and license eligibility depends on the user's classification, and frequency selected. Changes or modifications made by the user could void the user's authority to operate the equipment.**

## 8. Accessories & Parts

Order #:	Description
450131	Plastic clip for bodypack
OLM10	Omni lavalier mic w/windscreen and clip
450563	Windscreen for OLM10
300059000	Clip for OLM10
ULM20	Unidirectional lavalier mic w/ windscreen and clip
879155	ULM20 windscreen
879156	ULM20 clip
HM2	Unidirectional headset condenser mic
450124	Spring-adjusted mic stand adapter
71081001	Rack-mount kit - Single
71081002	Rack-mount kit - Double
730139	120-volt power supply (US/Canada type)
730140	230-volt power supply (EURO type)
730103	230-volt power supply (UK type)

## 9. Service/Warranty

### Factory Service

If factory service is required, ship the unit prepaid in its original carton to:

Telex EVI Audio GmbH  
Hirschberger Ring 45  
D-94315 Straubing  
Telephone: +49 (0) 9421 706 0  
Fax: +49 (0) 9421 706 350

Enclose a note describing the problem along with any other pertinent information.

### Warranty (Limited)

Electro-Voice products are guaranteed against malfunction due to defects in materials or workmanship for a specified period, as noted in the individual product-line statement(s) below, or in the individual product data sheet or owner's manual, beginning with the date of original purchase. If such malfunction occurs during the specified period, the product will be repaired or replaced (at our option) without charge. The product will be returned to the customer prepaid.

**Exclusions and Limitations:** The Limited Warranty does not apply to: (a) exterior finish or appearance; (b) certain specific described in the individual product-line statement(s) below, or in the individual product data sheet or owner's manual; (c) malfunction resulting from use or operation of the product other than as specified in the product data sheet or owner's manual; (d) malfunction resulting from misuse or abuse of the product; or (e) malfunction occurring at any time after repairs have been made to the product by anyone other than Electro-Voice or any of its authorized service representatives.

**Obtaining Warranty Service:** To obtain warranty service, the customer must deliver the product, prepaid, to Electro-Voice or any of its authorized service representatives together with proof of purchase of the product in the form of a bill of sale or receipted invoice. A list of authorized service representatives is available from Electro-Voice.

**Incidental and Consequential Damages Excluded:** Product repair or replacement and return to the customer are the only remedies provided to the customer. Electro-Voice shall not be liable for any incidental or consequential damages including, without limitation, injury to persons or property or loss of use.

**Electro-Voice Wireless Systems** are guaranteed against malfunction due to defects in materials or workmanship for a period of one (1) year from the date of original purchase. The Limited Warranty does not extend to cables or cable connectors. Additional details are included in the Uniform Limited Warranty Statement.

## Service/Warranty – North America

### Factory Service

If factory service is required, ship the unit prepaid in its original carton to:

EV Audio Service  
c/o Telex Communications  
8601 E. Cornhusker Highway  
Tel: 402/467-5321  
Fax: 402/467-3279

Enclose a note describing the problem along with any other pertinent information.

### Warranty (Limited)

Electro-Voice products are guaranteed against malfunction due to defects in materials or workmanship for a specified period, as noted in the individual product-line statement(s) below, or in the individual product data sheet or owner's manual, beginning with the date of original purchase. If such malfunction occurs during the specified period, the product will be repaired or replaced (at our option) without charge. The product will be returned to the customer prepaid.

**Exclusions and Limitations:** The Limited Warranty does not apply to: (a) exterior finish or appearance; (b) certain specific described in the individual product-line statement(s) below, or in the individual product data sheet or owner's manual; (c) malfunction resulting from use or operation of the product other than as specified in the product data sheet or owner's manual; (d) malfunction resulting from misuse or abuse of the product; or (e) malfunction occurring at any time after repairs have been made to the product by anyone other than Electro-Voice or any of its authorized service representatives.

**Obtaining Warranty Service:** To obtain warranty service, the customer must deliver the product, prepaid, to Electro-Voice or any of its authorized service representatives together with proof of purchase of the product in the form of a bill of sale or receipted invoice. A list of authorized service representatives is available from Electro-Voice.

**Incidental and Consequential Damages Excluded:** Product repair or replacement and return to the customer are the only remedies provided to the customer. Electro-Voice shall not be liable for any incidental or consequential damages including, without limitation, injury to persons or property or loss of use.

**Other Rights:** This warranty gives you specific legal rights and you may also have other rights which vary from state to state.

**Electro-Voice Wireless Systems** are guaranteed against malfunction due to defects in materials or workmanship for a period of one (1) year from the date of original purchase. The Limited Warranty does not extend to cables or cable connectors. Additional details are included in the Uniform Limited Warranty Statement.

# Electro-Voice®

Telex Communications Inc., 12000 Portland Ave. South  
Burnsville, MN 55337, USA 800/328-3771, 952/884-4051, Fax: 952/884-0043