



Description

The Crestron® TTK-MP/MPC/IPAC tabletop kit provides a tabletop enclosure for any MP series media presentation button panel, MPC and MPC3-302 series media presentation controller, or IPAC integrated professional automated computer. The device's front panel is angled at a fixed tilt of 45 degrees when installed in the enclosure. The complete assembly may be placed on any flat, level surface, with the option to install the assembly to the surface permanently using screws.

The optional SMK-MP/MPC/IPAC swivel mount kit enables the enclosure to be permanently mounted to a table, desk, or counter top surface, while retaining the ability to rotate. The swivel range may be customized with optional limiting screws.

The installation procedures for both the TTK-MP/MPC/IPAC and SMK-MP/MPC/IPAC are covered in this guide.

Additional Resources

Visit the product pages on the Crestron website (www.crestron.com) for additional information and the latest firmware updates. Use a QR reader application on your mobile device to scan the QR images.



TTK-MP/MPC/IPAC SMK-MP/MPC/IPAC

Prepare the TTK-MP/MPC/IPAC

The TTK-MP/MPC/IPAC provides two options for routing cables through the rear of the enclosure and one option for routing cables through the bottom of the enclosure.

To route a single cable through the rear of the enclosure:

1. Join the plug insert (open rear) and rubber cable grommet.

Joining the Plug Insert and Cable Grommet

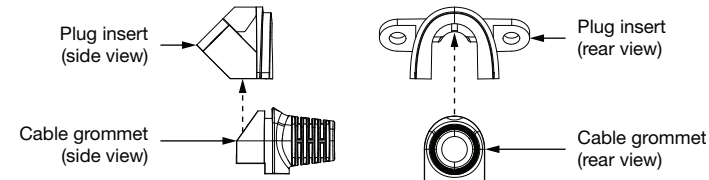

2. Attach the joined assembly to the TTK-MP/MPC/IPAC with the two 4-20 x 1/2" screws.

Attaching the Assembly to the TTK-MP/MPC/IPAC

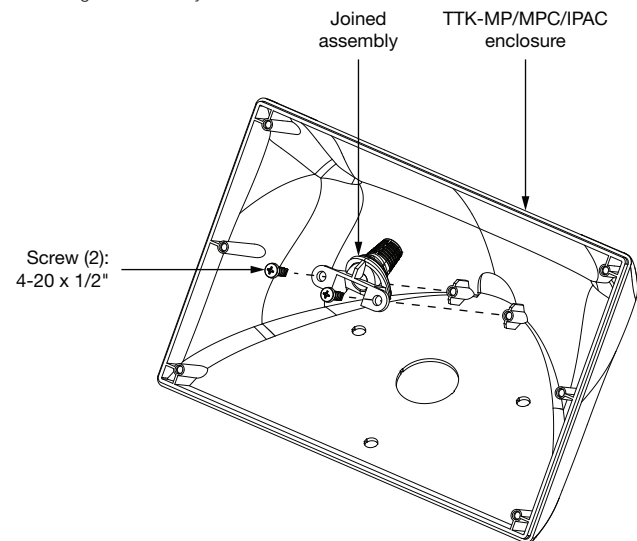

To route multiple cables through the rear of the enclosure, attach the wire capture to the TTK-MP/MPC/IPAC with the two included 4-20 x 1/2" screws.

Attaching the Wire Capture to the TTK-MP/MPC/IPAC

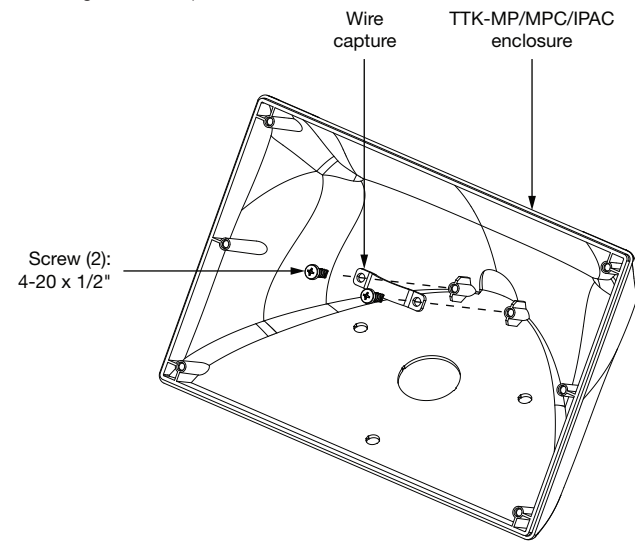

NOTE: The illustration above shows the metal wire capture installed "bow" side up. When fewer cables are routed through the rear of the TTK-MP/MPC/IPAC, install the metal wire capture "bow" side down to better secure the cables.

To route one or more cables through the bottom of the enclosure, attach the plug insert (closed rear) to the TTK-MP/MPC/IPAC with the two 4-20 x 1/2" screws.

Attaching the Plug Insert (Closed Rear) to the TTK-MP/MPC/IPAC

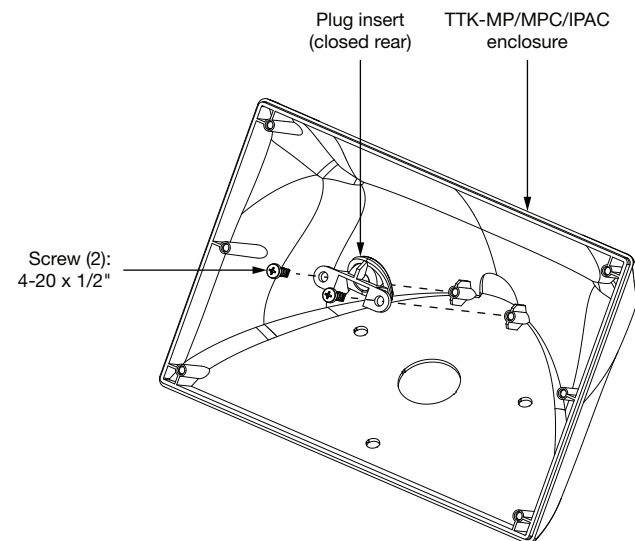

Install the TTK-MP/MPC/IPAC

Attach the TTK-MP/MPC/IPAC to a Flat Surface

To permanently attach the TTK-MP/MPC/IPAC to a table top or other flat surface:

1. If routing cables through the bottom of the TTK-MP/MPC/IPAC, cut an appropriately sized hole in the surface using the hole in the bottom of the TTK-MP/MPC/IPAC as a guide.
2. Use the three 8-16 x 1/2" screws to attach the TTK-MP/MPC/IPAC to the surface. Ensure that the hole in the table is aligned with the hole on the bottom of the TTK-MP/MPC/IPAC.

Attaching the TTK-MP/MPC/IPAC to a Flat Surface

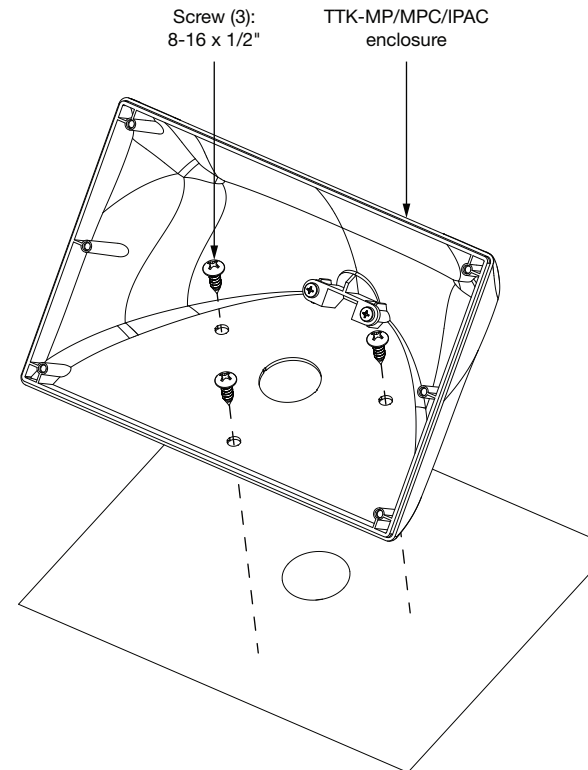

Install an MP/MPC/IPAC Device into the TTK-MP/MPC/IPAC

To install an MP, MPC, or IPAC device into the TTK-MP/MPC/IPAC:

1. If the device's front panel is still attached, remove the four 4-40 x 1/2" screws holding the panel in place, and then detach the panel from the device assembly.
2. Route all necessary cables through the bottom or rear of the TTK-MP/MPC/IPAC, and connect them to the rear of the assembly.
3. Insert two of the six 4-20 x 3/4" screws into the center screw holes on either side of the assembly, and attach the assembly to the TTK-MP/MPC/IPAC.

Attaching the Assembly to the TTK-MP/MPC/IPAC

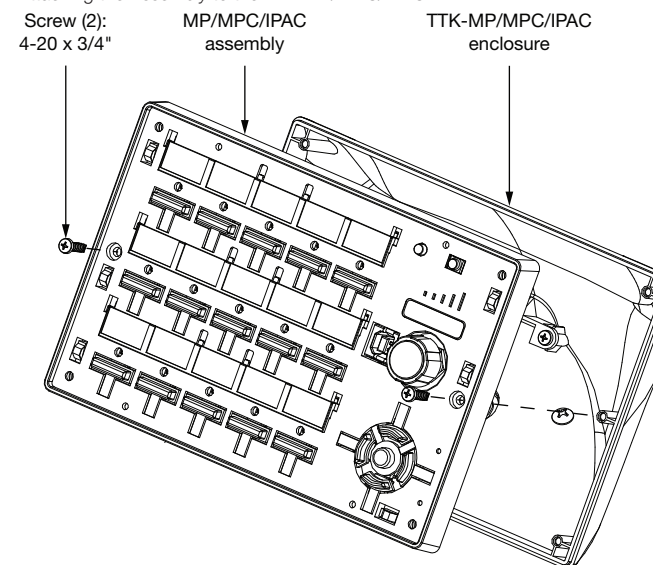

4. If necessary, attach or replace the button holders and button labels on the assembly. For more information refer to the MP, MPC, or IPAC device's documentation at www.crestron.com/manuals.
5. Place the front panel back on the assembly.
6. Insert the four remaining 4-20 x 3/4" screws into the corner screw holes on either side of the front panel, and secure the device to the TTK-MP/MPC/IPAC.

Attaching the Front Panel to the Assembly

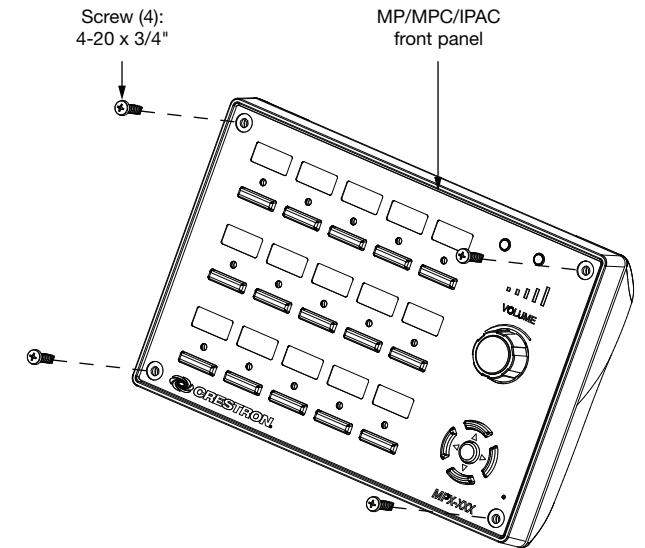

Install an MPC3-302 Device into the TTK-MP/MPC/IPAC

To install an MPC3-302 device into the TTK-MP/MPC/IPAC:

1. If the device's front panel is still attached, grasp both sides of the panel from the bottom, and pull upward firmly until the bottom half of the panel detaches from the assembly. Then, pull the top half of the panel upward firmly until it detaches from the assembly.
2. Route all necessary cables through the bottom or rear of the TTK-MP/MPC/IPAC, and connect them to the rear of the assembly.
3. Insert two of the six 4-20 x 3/4" screws into the center screw holes on either side of the assembly, and attach the assembly to the TTK-MP/MPC/IPAC.

Attaching the Assembly to the TTK-MP/MPC/IPAC

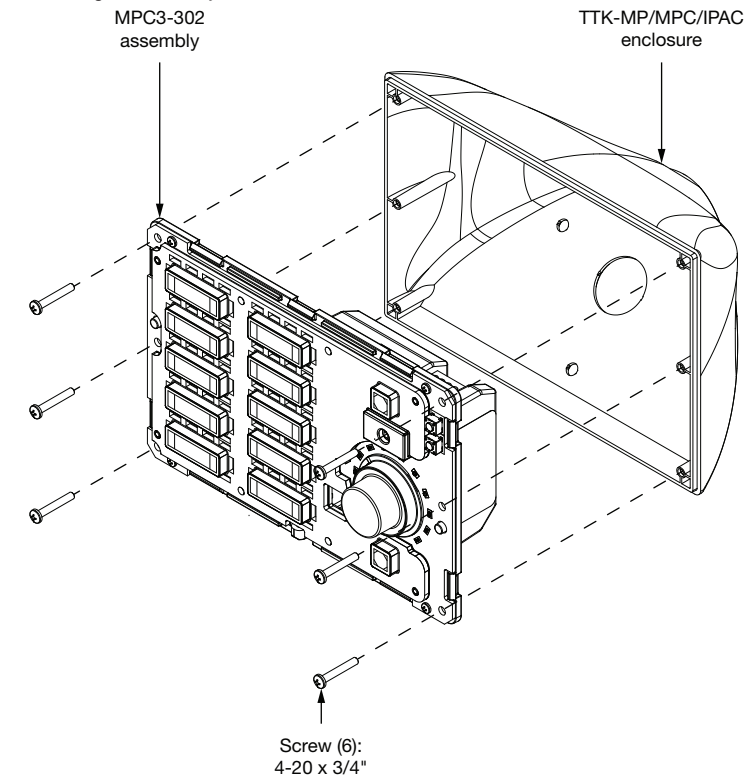

- If necessary, attach or replace the buttons and the button labels on the assembly. For more information, refer to the MPC3-302 DO Guide (Doc. 8249) at www.crestron.com/manuals.

- Align the front panel with the assembly so that all of the buttons align with their respective openings in the panel.

- Press the front panel into the assembly until the panel snaps into place.

Attaching the Front Panel to the Assembly

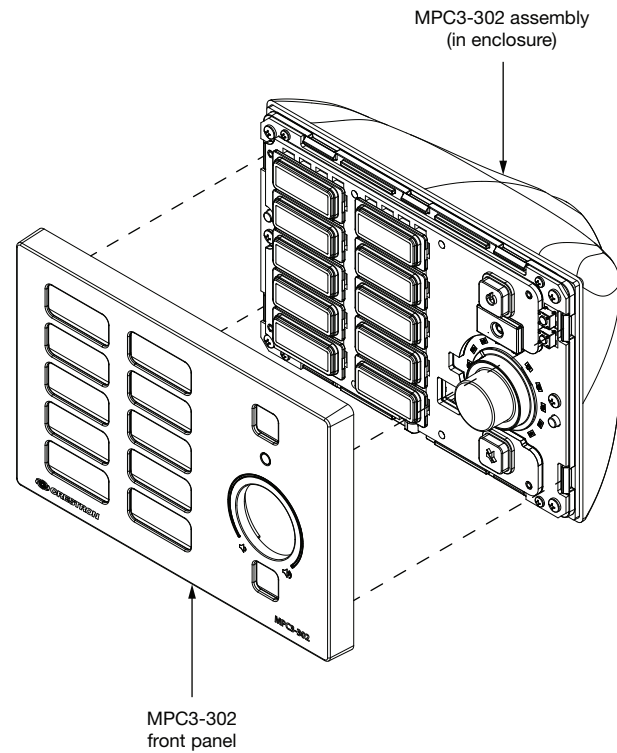

- Test the buttons to ensure that they can be pressed and released without becoming impeded by the front panel, and test the volume knob by rotating it gently. If any buttons are impeded or if the knob does not rotate easily, remove the panel as described in step 1, adjust the button and front panel placement, and then reattach the front panel.

CAUTION: Do not apply force when rotating the knob, and do not attempt to pull the knob away from the assembly.

- Using the drill bit included with the MPC3-302, screw the Torx® security screw included with the MPC3-302 into the screw hole on the bottom of the front panel to secure the panel to the assembly.

Attaching the Security Screw

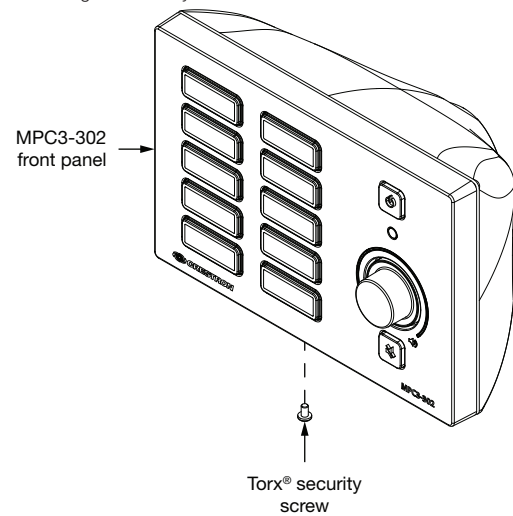

Install the SMK-MP/MPC/IPAC

Assemble the Swivel Mount

NOTE: If the SMK-MP/MPC/IPAC is being added to an existing TTK-MP/MPC/IPAC installation, remove the device's front panel and assembly from the TTK-MP/MPC/IPAC enclosure, and then remove the three 8-16 x 1/2" screws securing the enclosure to the surface.

To assemble the swivel mount:

- Attach the top of the swivel mechanism tube to the bottom of the TTK-MP/MPC/IPAC enclosure with the metal top plate and the three 8-32 nuts.

Attaching the Swivel Mechanism Tube

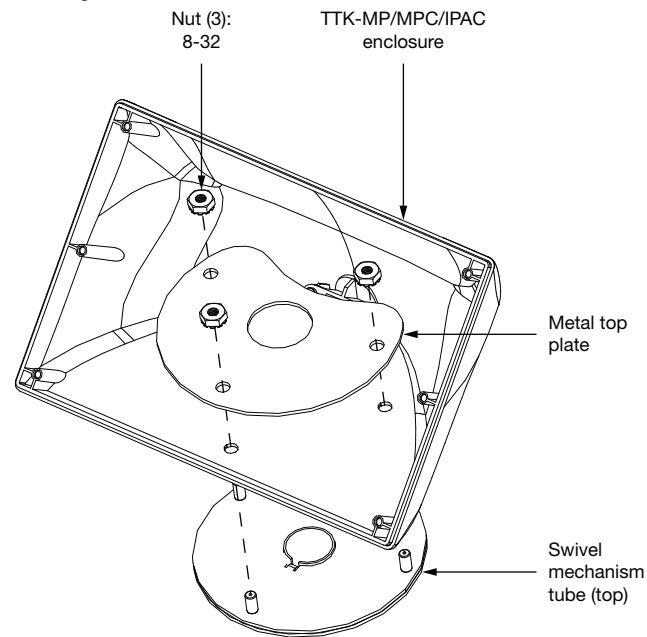

- If cables are to be routed through the bottom of the TTK-MP/MPC/IPAC, feed the full length of the cables through the swivel mechanism tube.
- Prepare the mounting surface using the cutout template provided with the SMK-MP/MPC/IPAC:
 - Ensure that the center hole diameter for the swivel mount is 7/8" minimum (22 mm), 15/16" maximum (24 mm).
 - Position the template so that the edge indicated as the front end of the surface aligns with the front position of the TTK-MP/MPC/IPAC.
 - Observe the dashed line indicating the front edge of the TTK-MP/MPC/IPAC to ensure that the device does not overhang the mounting surface.
- Using the six mounting holes on the swivel stop plate as a template, drill pilot holes 0.09" (2 mm) minimum, 0.12" (3 mm) maximum, and no deeper than 0.35" (9 mm) in the bottom of the mounting surface.
- Attach the swivel stop plate to the bottom of the mounting surface with the six 8-8B x 1/2" screws, then pass the swivel tube down through the mounting hole and stop plate. Refer to the illustration following step 7.

- Slide the provided hardware up onto the swivel tube in the order shown in the illustration following step 7.

NOTE: The keyed metal washer fits onto the swivel tube in one of two orientations. Orient the tab on the washer to face away from the permanently installed limiting screw in the swivel stop plate.

- Tighten and adjust the 7/8"-14 nut onto the swivel tube to achieve the desired resistance in swivel assembly motion.

NOTE: A flat tool (such as a large flat head screwdriver) may be placed in the slot on the bottom of the swivel tube to hold the tube still while tightening the nut.

Completing the Swivel Mount Assembly

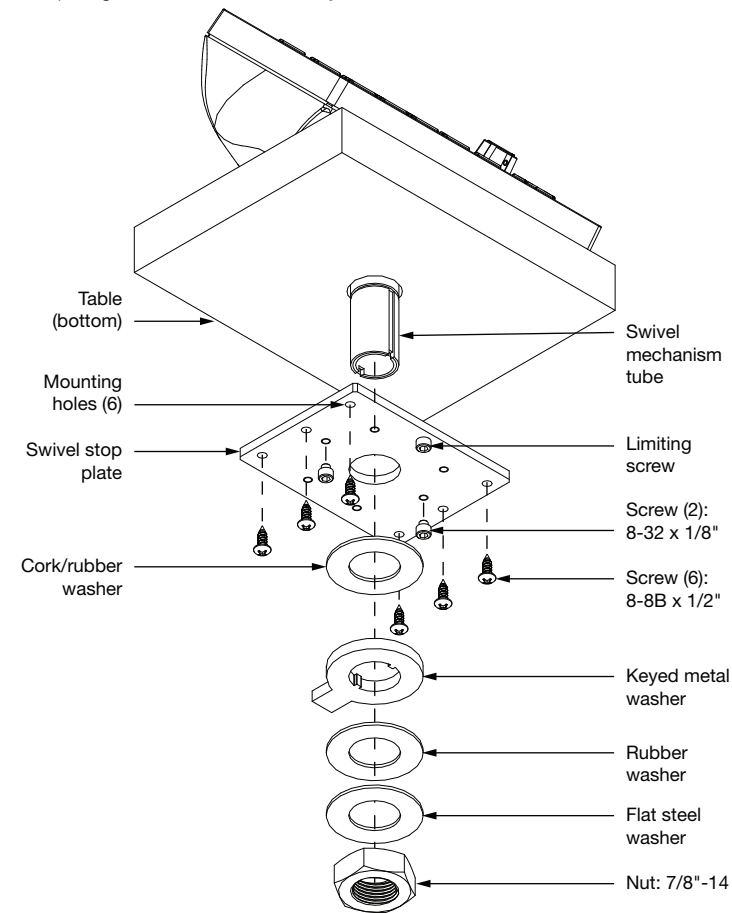

Customize the Swivel Range

Aside from the permanently installed limiting screw that is attached to the swivel stop plate, two additional 8-32 x 1/8" limiting screws can be attached to the swivel mount plate to set a custom range for swivel movement. Refer to the illustrations below.

Limiting Screw Locations in Swivel Stop Plate

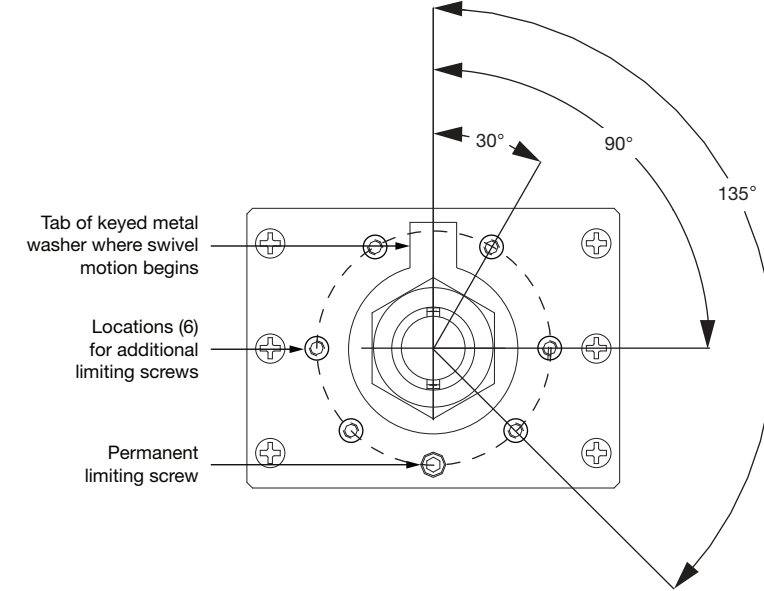

Swivel Stop Plate with Additional Limiting Screws

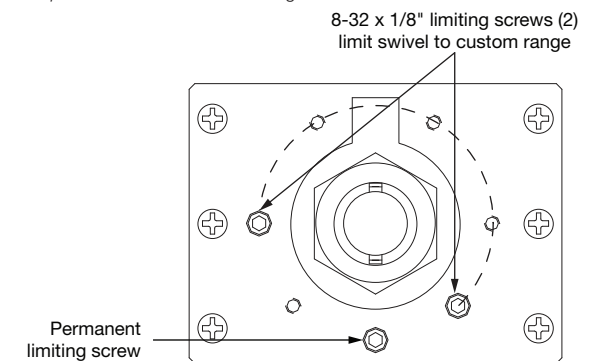

As of the date of manufacture, the product has been tested and found to comply with specifications for CE marking.



The product warranty can be found at www.crestron.com/legal/sales-terms-conditions-warranties. The specific patents that cover Crestron products are listed at www.crestron.com/legal/patents. Certain Crestron products contain open source software. For specific information, please visit www.crestron.com/legal/open-source-software.

Crestron and the Crestron logo are either trademarks or registered trademarks of Crestron Electronics, Inc. in the United States and/or other countries. Torx is either a trademark or a registered trademark of Acument Intellectual Properties, LLC, in the United States and/or other countries. Other trademarks, registered trademarks, and trade names may be used in this document to refer to either the entities claiming the marks and names or their products. Crestron disclaims any proprietary interest in the marks and names of others. Crestron is not responsible for errors in typography or photography.

This document was written by the Technical Publications department at Crestron.
©2018 Crestron Electronics, Inc.

Crestron Electronics, Inc.
15 Volvo Drive, Rockleigh, NJ 07647
Tel: 888.CRESTRON
Fax: 201.767.7576
www.crestron.com

Installation Guide - DOC. 6782D
(2023116)
03.18
Specifications subject to
change without notice.