

General Description

The Empath mixer combines the vision of Grandmaster Flash and Rane technology. Compact size, exceptional performance and advanced features set the Empath mixer apart. The Empath is the most able 3-channel, 10" format mixer available. The name implies: understanding, awareness and sensitivity to the needs of DJs.

The top plate is durable Lexan™, available in 3 versions:

- Original Blue
- Traditional Black on Black
- Grandmaster Flash Gold Signature Edition

All three versions have the same operating features. The Empath meets the requirements of all DJ genres:
trance · progressive · techno · jungle · funk · hip-hop · scratch · house · disco · drum 'n' bass · acid · live music · dance hall · freestyle · reggae · dub · garage · ambient

Features Important to DJs

- **Universal internal power supply.** When traveling, finding power supply adapters is difficult. The Empath accepts 100 to 240 VAC, 50/60 Hz power, for use anywhere in the world without adapters.
- **Auto-Gain** prevents performance-wrecking swings in program level when changing sources. The music is never too soft or clipped.
- **FlexFX™** is a post-fader external stereo effects loop with individual Dry/Wet pan controls for Mic and Input channels 1, 2 and 3.
- **Penny & Giles™** faders are simply the best money can buy. Smooth, accurate and reliable mixing is made possible by employing the most respected name in audio faders.
- **Two kinds of fader caps are provided** for different mixing preferences: soft rubber caps for smooth mixing, and hard plastic caps for fast mixing.
- **Flash-Cue** allows the DJ to rapidly select Crossfader A-Cue-sum or Crossfader B-Cue-sum with the flick of a switch, normally slow or complicated on other mixers.
- **Multiple Outputs.** Nothing is more frustrating than arriving at a club and finding their jacks don't match. Systems may have XLR, TRS or RCA connectors. The Empath provides all three.
- **Low and High headphone tone controls** allow the DJ to match their mixer to their headphones.
- **Both 1/8" and 1/4" headphone jacks** are simultaneously usable. More headphones are compatible with the Empath.
- **Two assignable CD triggers** work with any CD player with fader start ability.
- **Accelerated-Slope™**, full-cut, 3-band tone controls are the most flexible and highest quality available.
- **Crossfader assign switches** allow any Input Channel to be mixed on the A-side, B-side or Post Crossfader.
- **Level meters** view Stereo Cue, Stereo Master Mix, Split Cue or Main Output signals.

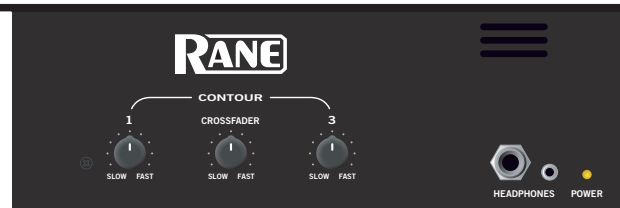
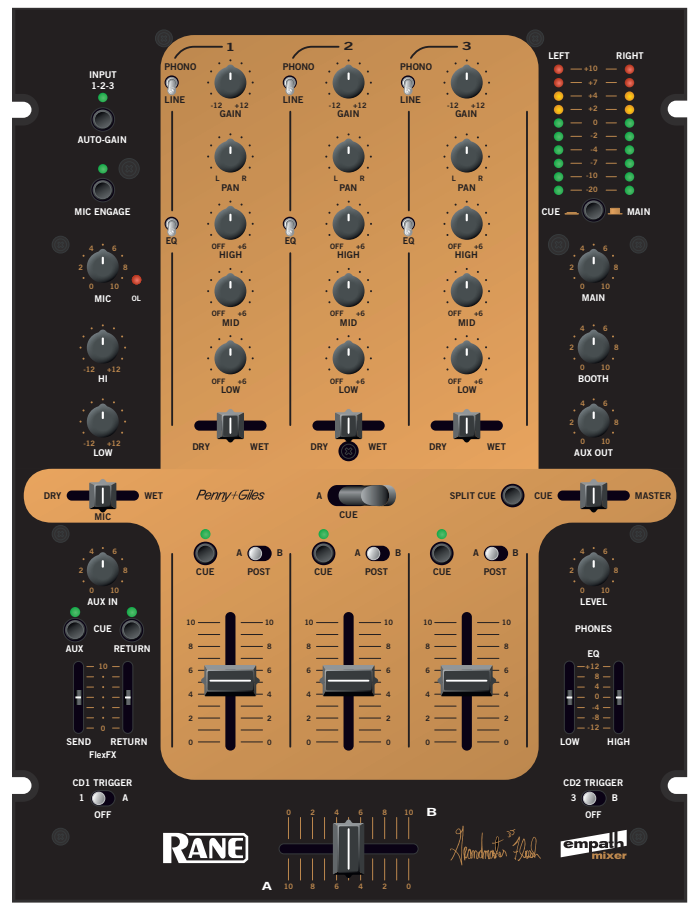

The Signature Edition comes with a rugged road case, including room underneath the mixer for cables and headphones. The case is also available separately.

Parameter	Specification	Conditions/Comments
Phono Inputs:	3 Stereo Unbalanced	RCA jacks
.....Response	RIAA	±1 dB
.....Input Impedance	47.5 kΩ, 200 pF	1 kHz
.....Gain	36 dB	1 kHz
Line Inputs:	3 Stereo Unbalanced	RCA jacks
.....Input Impedance	3.4 kΩ minimum	1 kHz
.....Gain	-12 to +12 dB	1 kHz
.....Tone controls (EQ)	3-band, Accelerated-Slope™	Full cut, see graph
Auxiliary Input:	1 Stereo Unbalanced	RCA jacks
.....Input Impedance	10 kΩ	1 kHz
.....Gain	Off to +10 dB	1 kHz
FlexFx Return:	Stereo Unbalanced	¼" TRS jacks
.....Input Impedance	10 kΩ	1 kHz
.....Gain	Off to +6 dB	1 kHz
Mic Input:	Active balanced	¼" TRS jack
.....Input Impedance	1022 Ω	511 Ω each leg to ground, 1 kHz
.....Gain	Off to +50 dB	1 kHz
.....Frequency Response	20 to 20 kHz	+0, -3 dB, Max gain
.....CMRR	>40 dB	1 kHz, Max gain
.....S/N	76 dB	Re +4 dBu, BW 20 to 20 kHz, gain 50 dB
.....Tone Control	2-band, ±12 dB	See graph
Main Output/Booth Output:	Stereo Balanced	XLR jacks, ¼" TRS jacks
.....Maximum Output	+24 dBu	
.....Output Impedance	100 Ω balanced each leg	
.....Gain	Off to +6 dB	
.....Frequency Response	20 Hz to 30 kHz	+0, -3 dB
.....THD+N	0.05%	Re +4 dBu, 20 to 20 kHz, 20 kHz BW
.....S/N	88 dB	Re +4 dBu, 20 kHz BW, unity gain
Aux Output:	Stereo Unbalanced	RCA jacks
.....Maximum Output	+20 dBu	
.....Output Impedance	300 Ω	1 kHz
.....Gain	Off to 0 dB	
FlexFX Send:	Stereo Unbalanced	¼" TRS jack
.....Output Impedance	300 Ω	1 kHz
.....Gain	Off to +6 dB	
Headphones:	Stereo	⅛" and ¼" TRS jacks
.....Power output	150 mW	150 Ω load
1-2-3 Auto-Gain	Automatic gain for channel 1-3 inputs	max gain adjust range ±12 dB
.....Target	0 dBu (775 mV)	no gain change
.....Threshold	-16 dBu (123 mV)	AGC actions starts, Gain holds indefinitely below threshold
.....Ratio	3:1	Input change : output change
.....Gain Increase	5.33 dB/second	see graph in Manual, page 2
.....Gain Decrease	32 dB/second	see graph in Manual, page 2
Power Supply Requirement	100-240 VAC, ±10%	50/60 Hz, 20 watts
Ambient Temperature	50° C (122° F) maximum	
Agency Listing Safety:UL	UL6500	E193164
.....cUL (Canada)	CAN/CSAE60065-00	
.....CE	LVD 73/23/EEC EN60065	
EMI: CE EMC	Directive 89/336/EEC	
.....FCC Part 15J	Certified Class B Device	
Construction All Steel		
.....Size	14"H x 10"W x 4"D	(35 cm x 25.4 cm x 10.16 cm)
.....Weight:	9 lb	(4 kg)
Shipping: Size:	7"H x 12"W x 19"D	17cm x 30cm x 48cm (prelim)
.....Weight:	11 lb	(5 kg)

Block Diagram

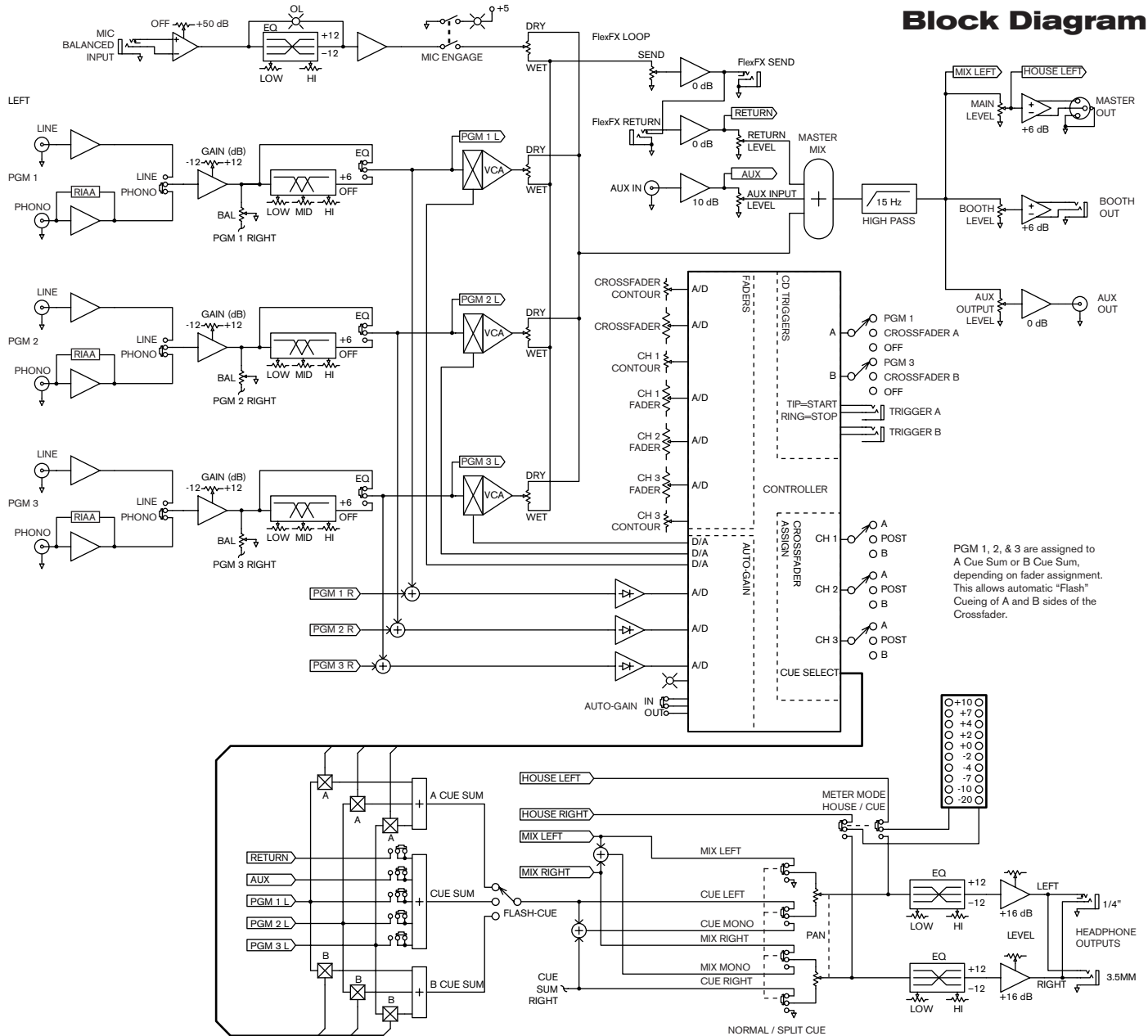

PGM 1, 2, & 3 are assigned to A Cue Sum or B Cue Sum, depending on fader assignment. This allows automatic "Flash" Cueing of A and B sides of the Crossfader.

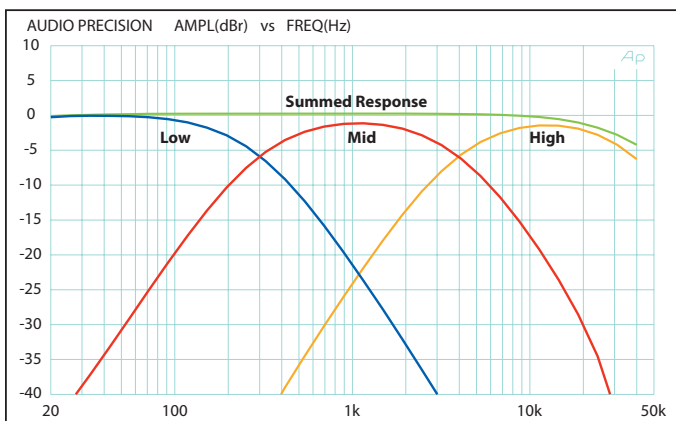

Three Program EQ filter bands and the flat summed response

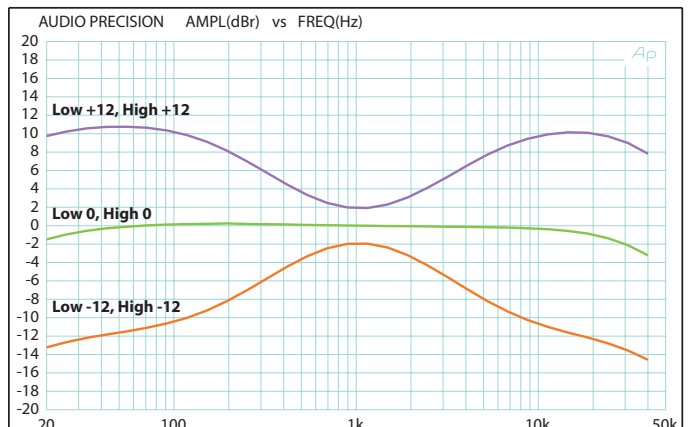

Combined response of the Mic and Headphone Tone controls

Fader Response

These graphs show curves representing upper and lower limits for gain response versus fader position. Contour controls allow smooth and continuous adjustment between the two responses.

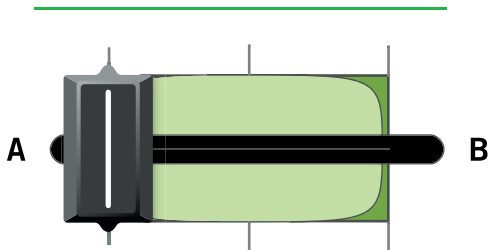
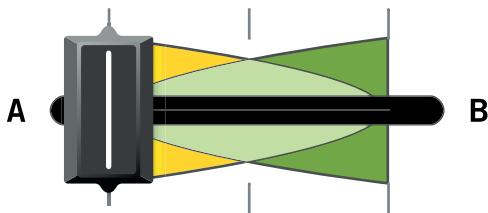
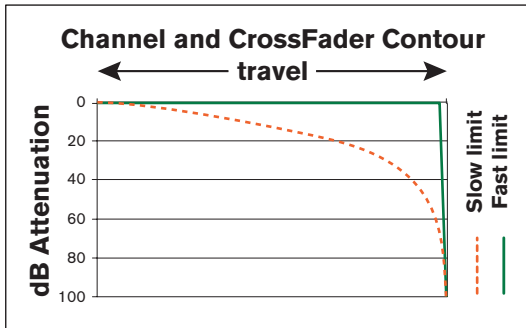

EQ Control Response

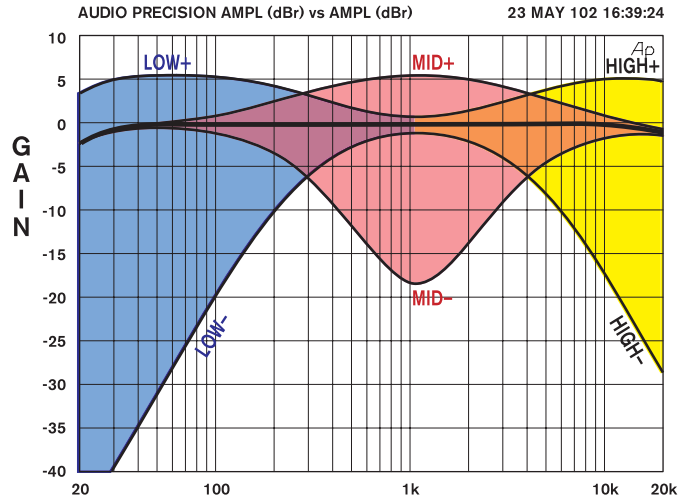

Interactivity of the Accelerated-Slope™ EQ controls

AGC Response

AGC looks at the input signal level (black line) and compares it to the ideal or "Target" level (0 dB). With AGC on, the gain is increased when it's above -16 dB, and decreased when it goes over the 0 dB Target (red line). Once AGC is active and falls below -16 dB, it is held indefinitely (blue line).

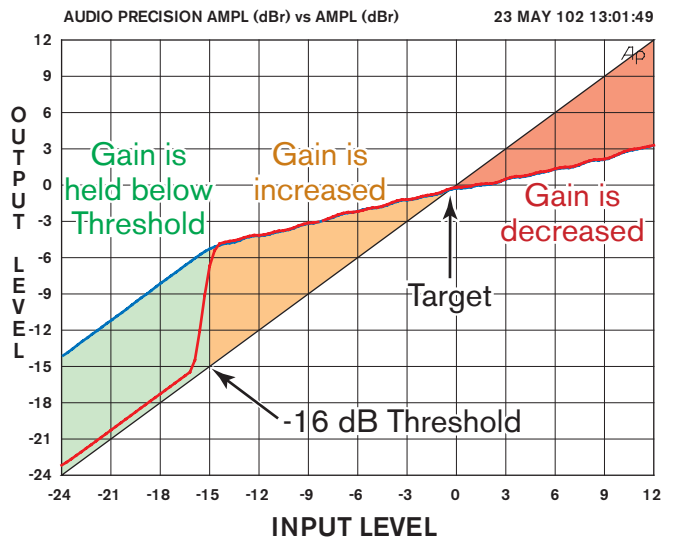

Rear Panel

