



XS-62S

HD VIDEO SWITCHER

Reference Manual

Contents

Menu List	2	Control Using the TALLY/GPIO and RS-422 Connector ...	25
1: VIDEO INPUT	2	Specification of the TALLY/GPI Connector	25
2: VIDEO OUTPUT	5	Inputting a Control Signal	25
3: TRANSITION	7	Outputting Tally Signals or Control Signals	25
4: COMPOSITION	8	Remote Control of a VISCA-compatible Video Camera	26
5: DSK	9		
6: AUDIO INPUT	10	LAN/RS-232 Command Reference	27
7: AUDIO OUTPUT	12	LAN Interface	27
8: AUDIO FOLLOW	14	RS-232 Interface	27
9: AUDIO EMBEDDED	15	Command Format	28
10: AUDIO AUTO MIXING	16	List of Commands	29
11: MODE	17		
12: PRESET MEMORY	18	Limitations in each Operating Mode	32
13: REMOTE	19		
14: LAN CONTROL	20		
15: USB MEMORY	21		
16: CAPTURE IMAGE	22		
17: SYSTEM	23		

Menu List

Pressing the [MENU] button makes the menu appear on the built-in display. If the HDMI OUT 3 connector's OUTPUT ASSIGN (p. 5) is set to "MULTI-VIEW," the OSD menu appears.

Built-in display (Menu)

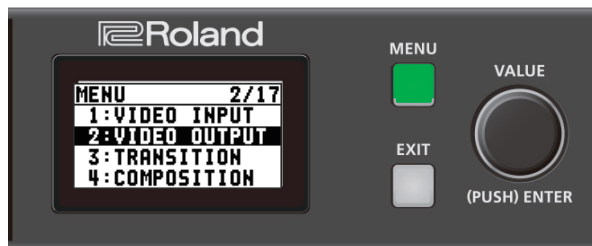

MEMO

- By turning the [VALUE] knob while pressing it, you can change the value more greatly.
- Pressing and holding the [VALUE] knob returns the current menu item you're setting to its default value.

Multi-view monitor (OSD menu)



1: VIDEO INPUT

Menu item	Value (bold text: default value)	Explanation
SDI IN 1-SDI IN 4		
INPUT STATUS	(ENTER)	This displays information about the incoming video (video format, size, etc.).
H FLIP	OFF , ON	Setting this to "ON" flips the output video horizontally.
BRIGHTNESS	-64- 0 -63	This adjusts the brightness.
CONTRAST	-64- 0 -63	This adjusts the contrast.
SATURATION	-64- 0 -63	This adjusts the saturation.
HDMI IN 5		
INPUT STATUS	(ENTER)	This displays information about the incoming video (video format, size, presence or absence of an HDCP signal, etc.).
FLICKER FILTER	OFF , ON	Setting this to "ON" reduces flicker.
ZOOM	10.0- 100.0 -1000.0% (*1)	This adjusts the zoom ratio.
SCALING TYPE	FULL	This always displays the picture expanded to full screen, irrespective of the aspect ratio of the input video.
	LETTERBOX	This enlarges or reduces the incoming video to a full-screen view while keeping the aspect ratio unchanged.
	CROP	This enlarges or reduces the incoming video so that the output picture has no blank margins while keeping the aspect ratio unchanged. Video extending beyond the borders is cut off.
	DOT BY DOT	This performs no scaling.
	MANUAL	Scale according to the "MANUAL SIZE H" and "MANUAL SIZE V" settings below.
MANUAL SIZE H (*2)	-2000- 0 -2000 (*1)	This adjusts the horizontal size.
MANUAL SIZE V (*2)	-2000- 0 -2000 (*1)	This adjusts the vertical size.
POSITION H	-1920- 0 -1920 (*1)	This adjusts the display position in the horizontal direction.
POSITION V	-1200- 0 -1200 (*1)	This adjusts the display position in the vertical direction.
H FLIP	OFF , ON	Setting this to "ON" flips the output video horizontally.
BRIGHTNESS	-64- 0 -63	This adjusts the brightness.
CONTRAST	-64- 0 -63	This adjusts the contrast.
SATURATION	-64- 0 -63	This adjusts the saturation.
RED	-64- 0 -63	This adjusts the red level.
GREEN	-64- 0 -63	This adjusts the green level.
BLUE	-64- 0 -63	This adjusts the blue level.

Menu item	Value (bold text: default value)	Explanation
EDID	INTERNAL , 800 x 600, 1024 x 768, 1200 x 800, 1366 x 768, 1280 x 1024, 1400 x 1050, 1600 x 1200, 1920 x 1200, 720p, 1080i, 1080p	This sets the input format (EDID) for the HDMI IN 5 connector.

(*1) The range of this value varies according to conditions such as the input/output format.

(*2) This is available when "SCALING TYPE" is set to "MANUAL."

Menu item	Value (bold text: default value)	Explanation
HDMI/ANLG IN 6 (*3)		
INPUT STATUS	(ENTER)	This displays information about the incoming video (video format, size, presence or absence of an HDCP signal, etc.).
INPUT 6 ASSIGN	HDMI , RGB/COMPONENT, COMPOSITE	This sets the input connector assigned to channel 6.
AUTO SAMPLING (*4)	(EXEC)	This automatically adjusts the image quality. * Depending on the video, adjusting the image quality might not be possible.
FLICKER FILTER	OFF , ON	Setting this to "ON" reduces flicker.
ZOOM	10.0– 100.0 –1000.0% (*5)	This adjusts the zoom ratio.
SCALING TYPE	FULL	This always displays the picture expanded to full screen, irrespective of the aspect ratio of the input video.
	LETTERBOX	This enlarges or reduces the incoming video to a full-screen view while keeping the aspect ratio unchanged.
	CROP	This enlarges or reduces the incoming video so that the output picture has no blank margins while keeping the aspect ratio unchanged. Video extending beyond the borders is cut off.
	DOT BY DOT	This performs no scaling.
	MANUAL	Scale according to the "MANUAL SIZE H" and "MANUAL SIZE V" settings below.
MANUAL SIZE H (*6)	-2000– 0 –2000 (*5)	This adjusts the horizontal size.
MANUAL SIZE V (*6)	-2000– 0 –2000 (*5)	This adjusts the vertical size.
POSITION H	-1920– 0 –1920 (*5)	This adjusts the display position in the horizontal direction.
POSITION V	-1200– 0 –1200 (*5)	This adjusts the display position in the vertical direction.
H FLIP	OFF , ON	Setting this to "ON" flips the output video horizontally.
BRIGHTNESS	-64– 0 –63	This adjusts the brightness.
CONTRAST	-64– 0 –63	This adjusts the contrast.
SATURATION	-64– 0 –63	This adjusts the saturation.
RED	-64– 0 –63	This adjusts the red level.
GREEN	-64– 0 –63	This adjusts the green level.
BLUE	-64– 0 –63	This adjusts the blue level.
FREQUENCY (*4)	-128– 0 –127	This adjusts the input frequency.
PHASE (*4)	-128– 0 –127	This adjusts the phase.
EDID (*7)	INTERNAL , 800 x 600, 1024 x 768, 1200 x 800, 1366 x 768, 1280 x 1024, 1400 x 1050, 1600 x 1200, 1920 x 1200, 720p (*8), 1080i (*8), 1080p (*8)	This sets the input format (EDID) of the HDMI IN 6 connector or the RGB/CMPNT/CMPST IN connector.

(*3) The settings on the HDMI/ANLG IN 6 menu change in tandem with the assignment made using "INPUT 6 ASSIGN." You can make separate individual settings for the respective menu items for the HDMI IN 6 connector and the RGB/CMPNT/CMPST IN 6 connector.

(*4) This is effective when "INPUT 6 ASSIGN" is set to "RGB/COMPONENT."

(*5) The range of this value varies according to conditions such as the input/output format.

(*6) This is available when "SCALING TYPE" is set to "MANUAL."

(*7) This is available only when "INPUT 6 ASSIGN" is set to "HDMI" or "RGB/COMPONENT."

(*8) This is available only when "INPUT 6 ASSIGN" is set to "HDMI."

Menu item	Value (bold text: default value)	Explanation	
STILL/BKG IN 7/8			
INPUT 7 ASSIGN	STILL IMAGE 1 , STILL IMAGE 2, BACKGROUND	This assigns a still image or monochrome picture (background color) to channel 7 or 8.	
		STILL IMAGE 1 , STILL IMAGE 2	This selects the memory where a still image is saved and assigns the image. A "*" symbol is displayed for memory where a still image is already saved.
INPUT 8 ASSIGN	STILL IMAGE 1, STILL IMAGE 2 , BACKGROUND	BACKGROUND	This assigns a monochrome picture (background color).
		This sets the background color. * The background-color setting is shared by channels 7 and 8.	
BACKGROUND COLOR	BLACK , WHITE, GRAY, RED, GREEN, BLUE, YELLOW		

2: VIDEO OUTPUT

Menu item	Value (bold text: default value)	Explanation
SDI OUT 1, 2		
OUTPUT STATUS	—	This displays the video format. When “HDCP” (p. 23) is set to “ON,” “HDCP MASKED” is displayed and no video is output from the SDI OUT connectors.
OUTPUT ASSIGN	PGM/1, PVW/2, AUX/3 The default values are as follows. SDI OUT 1: PGM/1 SDI OUT 2: PVW/2	This sets the output bus assigned to the SDI OUT connectors.
3G-SDI MAPPING	LEVEL-A, LEVEL-B	This sets the mapping structure for 3G-SDI output.
H FLIP	OFF , ON	Setting this to “ON” flips the output video horizontally.
BRIGHTNESS	-64- 0 -63	This adjusts the brightness.
CONTRAST	-64- 0 -63	This adjusts the contrast.
SATURATION	-64- 0 -63	This adjusts the saturation.
HDMI OUT 1, 2		
OUTPUT STATUS	—	This displays information about the output video (video format and presence or absence of an HDCP signal). When no connection is in effect, “NOT CONNECTED” is displayed.
OUTPUT ASSIGN	PGM/1, PVW/2, AUX/3 The default values are as follows. HDMI OUT 1: PGM/1 HDMI OUT 2: PVW/2	This sets the output bus assigned to the HDMI OUT connectors.
COLOR SPACE	YCC , RGB (0–255), RGB (16–235)	This sets the color space.
DVI-D/HDMI SIGNAL	DVI-D, HDMI	This sets the output mode for HDMI output.
H FLIP	OFF , ON	Setting this to “ON” flips the output video horizontally.
BRIGHTNESS	-64- 0 -63	This adjusts the brightness.
CONTRAST	-64- 0 -63	This adjusts the contrast.
SATURATION	-64- 0 -63	This adjusts the saturation.
RED	-64- 0 -63	This adjusts the red level.
GREEN	-64- 0 -63	This adjusts the green level.
BLUE	-64- 0 -63	This adjusts the blue level.
HDMI OUT 3		
OUTPUT STATUS	–	This displays information about the output video (video format and presence or absence of an HDCP signal). When no connection is in effect, “NOT CONNECTED” is displayed. * If OUTPUT ASSIGN is set to “MULTI-VIEW” for the HDMI OUT 3 connector, the output format is fixed at “1080p.”
OUTPUT ASSIGN	PGM/1, PVW/2, AUX/3, MULTI-VIEW	This sets the output bus assigned to the HDMI OUT 3 connector.
RESOLUTION (*9)	480p, 720p, 1080p, 800 x 600, 1024 x 768, 1280 x 800, 1366 x 768, 1280 x 1024, 1400 x 1050, 1600 x 1200, 1920 x 1200	This sets the output resolution using the scaler.
COLOR SPACE	YCC , RGB (0–255), RGB (16–235)	This sets the color space.
DVI-D/HDMI	DVI-D, HDMI	This sets the output mode for HDMI output.
ZOOM (*9)	10.0- 100.0 -1000.0% (*10)	This adjusts the zoom ratio.

Menu item	Value (bold text: default value)	Explanation
SCALING TYPE (*9)	FULL	This always displays the picture expanded to full screen, irrespective of the aspect ratio of the input video.
	LETTERBOX	This enlarges or reduces the incoming video to a full-screen view while keeping the aspect ratio unchanged.
	CROP	This enlarges or reduces the incoming video so that the output picture has no blank margins while keeping the aspect ratio unchanged. Video extending beyond the borders is cut off.
	DOT BY DOT	This performs no scaling.
	MANUAL	Scale according to the "MANUAL SIZE H" and "MANUAL SIZE V" settings below.
H FLIP (*9)	OFF , ON	Setting this to "ON" flips the output video horizontally.
MANUAL SIZE H (*9) (*11)	-2000- 0 -2000 (*10)	This adjusts the horizontal size.
MANUAL SIZE V (*9) (*11)	-2000- 0 -2000 (*10)	This adjusts the vertical size.
POSITION H (*9)	-1920- 0 -1920 (*10)	This adjusts the display position in the horizontal direction.
POSITION V (*9)	-1200- 0 -1200 (*10)	This adjusts the display position in the vertical direction.
BRIGHTNESS	-64- 0 -63	This adjusts the brightness.
CONTRAST	-64- 0 -63	This adjusts the contrast.
SATURATION	-64- 0 -63	This adjusts the saturation.
RED	-64- 0 -63	This adjusts the red level.
GREEN	-64- 0 -63	This adjusts the green level.
BLUE	-64- 0 -63	This adjusts the blue level.

(*9) This is valid when the HDMI OUT 3 connector's OUTPUT ASSIGN (p. 5) is set to something other than "MULTI-VIEW."























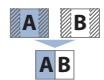

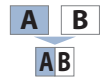
(*10) The range of this value varies according to conditions such as the input/output format.

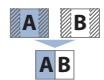
(*11) Only when "SCALING TYPE" is set to "MANUAL."

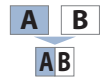
3: TRANSITION

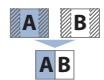
Menu item	Value (bold text: default value)	Explanation
TIME	0.0– 1.0 –4.0 sec	This sets the video transition time.
TYPE	CUT, MIX , WIPE	This sets the type of video transition.
MIX TYPE	MIX , FAM, NAM	This specifies the mix pattern.
WIPE TYPE	H-DOWN, H-UP, V-RIGHT, V-LEFT, H-IN, H-OUT, V-IN, V-OUT, R-DOWN, L-DOWN, R-UP, L-UP, BLOCK, V-GRID, H-GRID, H-DOWN s, H-UP s, V-RIGHT s, V-LEFT s, H-IN s, H-OUT s, V-IN s, V-OUT s, R-DOWN s, L-DOWN s, R-UP s, L-UP s, BLOCK s, V-GRID s, H-GRID s	This specifies the wipe pattern. * Setting values indicated with “s” are soft edge wipe patterns.

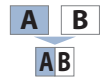
4: COMPOSITION

Menu item	Value (bold text: default value)	Explanation								
COMPOSITION TYPE	PinP, SPLIT	This selects the type of video composition.								
PinP SIZE	1/4, 1/3 , 1/2	This sets the size of the inset screen. The horizontal width (and vertical height) of the inset screen are set to 1/2, 1/3, or 1/4 the size values of the background video.								
PinP POS H	-45.0–45.0% (*12)	This adjusts the horizontal display position of the inset screen.								
PinP POS V	-40.0– -25.0 –40.0% (*12)	This adjusts the vertical display position of the inset screen.								
PinP BDR COLOR	BLACK, WHITE , GRAY, RED, GREEN, BLUE, YELLOW, SOFT EDGE	This sets the color of the border for the inset screen. Setting this to “SOFT EDGE” blurs the edge.								
PinP BDR WIDTH	0– 1 –15	This adjusts the width of the border for the inset screen.								
PinP SHAPE	SQUARE , CIRCLE, HEART, DIAMOND	This specifies the shape of the inset screen. <table border="1" style="margin-left: 20px;"> <thead> <tr> <th>SQUARE</th> <th>CIRCLE</th> <th>HEART</th> <th>DIAMOND</th> </tr> </thead> <tbody> <tr> <td></td> <td></td> <td></td> <td></td> </tr> </tbody> </table>	SQUARE	CIRCLE	HEART	DIAMOND				
SQUARE	CIRCLE	HEART	DIAMOND							
										
PinP ASPECT	16:9 , 1:1	This sets the aspect ratio of the inset screen.								
SPLIT PATTERN	V-CENTER , H-CENTER, V-STRETCH, H-STRETCH	This sets the split composition pattern. <table border="1" style="margin-left: 20px;"> <thead> <tr> <th>V-CENTER</th> <th>H-CENTER</th> </tr> </thead> <tbody> <tr> <td>This vertically crops the center section of the video. </td> <td>This horizontally crops the center section of the video. </td> </tr> <tr> <th>V-STRETCH</th> <th>H-STRETCH</th> </tr> <tr> <td>This stretches the video vertically. </td> <td>This stretches the video horizontally. </td> </tr> </tbody> </table>	V-CENTER	H-CENTER	This vertically crops the center section of the video. 	This horizontally crops the center section of the video. 	V-STRETCH	H-STRETCH	This stretches the video vertically. 	This stretches the video horizontally. 
V-CENTER	H-CENTER									
This vertically crops the center section of the video. 	This horizontally crops the center section of the video. 									
V-STRETCH	H-STRETCH									
This stretches the video vertically. 	This stretches the video horizontally. 									
SPLIT PGM-CTR	-25.0– 0.0 –25.0%	This is applied when “PATTERN” is set to “V-CENTER” or “H-CENTER.” <ul style="list-style-type: none"> When at V-CENTER This horizontally adjusts the display position of the video placed on the left side. When at H-CENTER This vertically adjusts the display position of the video placed above. 								
SPLIT PST-CTR	-25.0– 0.0 –25.0%	This is applied when “PATTERN” is set to “V-CENTER” or “H-CENTER.” <ul style="list-style-type: none"> When at V-CENTER This horizontally adjusts the display position of the video placed on the right side. When at H-CENTER This vertically adjusts the display position of the video placed below. 								

(*12) The range of this value varies according to conditions such as the input/output format.

5: DSK

Menu item	Value (bold text: default value)	Explanation
DSK SOURCE CH	SDI IN 1–SDI IN 4, HDMI IN 5, HDMI/ANLG IN 6 , STILL/BKG IN 7, STILL/BKG IN 8	During DSK compositing, this specifies the channel of the overlaid logo or image. Setting this to “STL/BKG IN 7” or “STL/BKG IN 8” performs DSK composition using a still image saved in the unit.
KEY TYPE	LUMI-WHT, LUMI-BLK, CRM-GRN, CRM-BLU	This specifies the key type (extraction color) used during DSK composition.
		LUMI-WHT This uses a brightness threshold to make white transparent.
		LUMI-BLK This uses a brightness threshold to make black transparent.
		CRM-GRN This uses a color threshold to make green transparent.
CRM-BLU This uses a color threshold to make blue transparent.		
LEVEL	0– 64 –255	This adjusts the degree of extraction (transparency) for the key.
GAIN	0 –255	This adjusts the degree of edge blur (semi-transmissive region) for the key.
MIX LEVEL	0– 255	This adjusts the key’s overall density (output level).
HUE WIDTH (*13)	-128– 0 –127	This adjusts the hue width for the key color.
HUE FINE (*13)	-128– 0 –127	This adjusts the center position of the hue for the key color.
SATURATION WIDTH (*13)	-128– 0 –127	This adjusts the saturation width for the key color.
SATURATION FINE (*13)	0 –255	This adjusts the center position of saturation for the key color.
PGM OUT	OFF , ON	This sets DSK composition on or off. When this is turned on, the results of DSK composition are sent to final output. When the menu is used to turn on DSK composition, the video is composited immediately, regardless of the length of time set for video transitions.
PVW OUT	OFF , ON	Setting this to “ON” makes the DSK compositing results the preview output. The [PVW] button functions as a shortcut for “PVW OUT.”

(*13) This is applied when “KEY TYPE” is set to “CRM-GRN” or “CRM-BLU.”

6: AUDIO INPUT

Menu item	Value (bold text: default value)	Explanation
AUDIO IN 1–AUDIO IN 4		
HEAD AMP GAIN	0 –64dB	This adjusts head amp gain. Head amp gain adjusts analog audio.
DIGITAL GAIN	–42.0– 0.0 –42.0dB	This adjusts digital gain. Digital gain adjusts digital audio internally converted from analog to digital in the XS-62S.
PGM LEVEL	-INF –10.0dB	This adjusts the level that is output to the PGM/1 bus.
PVW LEVEL	-INF –10.0dB	This adjusts the level that is output to the PVW/2 bus.
PGM MUTE	OFF , ON	This turns on/off the mute function for the PGM/1 bus. If this is “ON,” the audio of the PGM/1 bus is muted (silent).
PVW MUTE	OFF , ON	This turns on/off the mute function for the PVW/2 bus. If this is “ON,” the audio of the PVW/2 bus is muted (silent).
PAN	LEFT– CENTER –RIGHT	This adjusts the sound position (pan).
HPF 75Hz	OFF , ON	This sets the high-pass filter on or off. Effect This cuts off unneeded low-band audio. The cutoff frequency is 75 Hz.
DELAY	0.0 –12.0frame	This adjusts the delay time for input audio. Effect This outputs audio with a delay.
GATE	OFF , ON	This sets gate on or off. Effect This mutes audio that is below a specified level.
GATE THLD	–80.0– -50.0 –0.0dB	This sets the level used as the threshold for removing audio. Audio below the level set here is removed.
GATE RELEASE	30– 860 –5000ms	This adjusts the length of time until the audio is fully attenuated after audio falls below the threshold.
COMP	OFF , ON	This sets the compressor on or off. Effect This compresses audio that exceeds a specified level.
COMP THLD	–60.0– -30.0 –0.0dB	This sets the level used as the threshold at which the compressor is applied. Compression is applied to audio that exceeds the threshold.
COMP RATIO	1.00:1, 1.12:1, 1.25:1, 1.40:1, 1.60:1, 1.80:1, 2.00:1, 2.50:1, 3.20:1, 4.00:1, 5.60:1 , 8.00:1, 16.0:1, INF:1	This species the degree of compression applied to the audio. If this is set to “1.00:1,” compression is not applied.
COMP ATTACK	0.2– 1 –100ms	This sets the time until compression starts when audio exceeding the threshold is input.
COMP RELEASE	30– 380 –5000ms	This adjusts the length of time until compression ends after audio falls below the threshold.
COMP AUTO G	OFF, ON	This switches the auto makeup gain feature on and off. When this is set to “ON,” the final output volume level after applying the compressor is automatically adjusted according to the “COMP THLD” and “COMP RATIO” settings. The total of the “COMP MAKE UP G” setting value described below and the value calculated by auto makeup gain becomes the final output volume level (up to +34 dB).
COMP MAKE UP G	–40– 0.0 –40dB	This adjusts the final output volume level after applying the compressor.
EQ Hi	–15.0– 0.0 –15.0dB	This boosts or attenuates the high band.
EQ Hi FREQ	1.00– 10.0 –20.0kHz	This adjusts the center frequency when changing the tone quality in the high band.
EQ Mid	–15.0– 0.0 –15.0dB	This boosts or attenuates the middle band.
EQ Mid FREQ	20.0Hz– 500Hz –20.0kHz	This adjusts the center frequency when changing the tone quality in the middle band.
EQ Mid Q	0.5– 1.0 –16.0	This adjusts the width of the frequency band when boosting or attenuating the middle band.
EQ Lo	–15.0– 0.0 –15.0dB	This boosts or attenuates the low band.
EQ Lo FREQ	20.0– 100 –500Hz	This adjusts the center frequency when changing the tone quality in the low band.

Menu item	Value (bold text: default value)	Explanation
AUDIO IN 5/6, SDI IN 1–SDI IN 4, HDMI IN 5, HDMI IN 6		
DIGITAL GAIN	-42.0– 0.0 –42.0dB	This adjusts digital gain.
PGM LEVEL	-INF –10.0dB	This adjusts the level that is output to the PGM/1 bus.
PVW LEVEL	-INF –10.0dB	This adjusts the level that is output to the PVW/2 bus.
PGM MUTE	OFF , ON	This turns on/off the mute function for the PGM/1 bus. If this is “ON,” the audio of the PGM/1 bus is muted (silent).
PVW MUTE	OFF , ON	This turns on/off the mute function for the PVW/2 bus. If this is “ON,” the audio of the PVW/2 bus is muted (silent).
HPF 75Hz	OFF , ON	This sets the high-pass filter on or off. Effect This cuts off unneeded low-band audio. The cutoff frequency is 75 Hz.
DELAY	0.0 –12.0frame	This adjusts the delay time for input audio. Effect This outputs audio with a delay.
GATE	OFF , ON	This sets gate on or off. Effect This mutes audio that is below a specified level.
GATE THLD	-80.0– -50.0 –0.0dB	This sets the level used as the threshold for removing audio. Audio below the level set here is removed.
GATE RELEASE	30– 860 –5000ms	This adjusts the length of time until the audio is fully attenuated after audio falls below the threshold.
COMP	OFF , ON	This sets the compressor on or off. Effect This compresses audio that exceeds a specified level.
COMP THLD	-60.0– -30.0 –0.0dB	This sets the level used as the threshold at which the compressor is applied. Compression is applied to audio that exceeds the threshold.
COMP RATIO	1.00:1, 1.12:1, 1.25:1, 1.40:1, 1.60:1, 1.80:1, 2.00:1, 2.50:1, 3.20:1, 4.00:1, 5.60:1 , 8.00:1, 16.0:1, INF:1	This species the degree of compression applied to the audio. If this is set to “1.00:1,” compression is not applied.
COMP ATTACK	0.2– 1 –100ms	This sets the time until compression starts when audio exceeding the threshold is input.
COMP RELEASE	30– 380 –5000ms	This adjusts the length of time until compression ends after audio falls below the threshold.
COMP AUTO G	OFF, ON	This switches the auto makeup gain feature on and off. When this is set to “ON,” the final output volume level after applying the compressor is automatically adjusted according to the “COMP THLD” and “COMP RATIO” settings. The total of the “COMP MAKE UP G” setting value described below and the value calculated by auto makeup gain becomes the final output volume level (up to +34 dB).
COMP MAKE UP G	-40– 0.0 –40dB	This adjusts the final output volume level after applying the compressor.
EQ Hi	-15.0– 0.0 –15.0dB	This boosts or attenuates the high band.
EQ Hi FREQ	1.00– 10.0 –20.0kHz	This adjusts the center frequency when changing the tone quality in the high band.
EQ Mid	-15.0– 0.0 –15.0dB	This boosts or attenuates the middle band.
EQ Mid FREQ	20.0Hz– 500Hz –20.0kHz	This adjusts the center frequency when changing the tone quality in the middle band.
EQ Mid Q	0.5– 1.0 –16.0	This adjusts the width of the frequency band when boosting or attenuating the middle band.
EQ Lo	-15.0– 0.0 –15.0dB	This boosts or attenuates the low band.
EQ Lo FREQ	20.0– 100 –500Hz	This adjusts the center frequency when changing the tone quality in the low band.

7: AUDIO OUTPUT

Menu item	Value (bold text: default value)	Explanation						
OUTPUT ASSIGN								
AUDIO OUT (XLR)	PGM/1 , PVW/2, AUX/3	This specifies the audio bus assigned to the AUDIO OUT connectors (XLR), AUDIO OUT connectors (RCA), and PHONES connector.						
AUDIO OUT (RCA)	PGM/1 , PVW/2, AUX/3	<table border="1"> <tr> <td>PGM/1</td> <td>This outputs only the audio on the PGM/1 bus.</td> </tr> <tr> <td>PVW/2</td> <td>This outputs only the audio on the PVW/2 bus.</td> </tr> <tr> <td>AUX/3</td> <td>This outputs only the audio on the AUX/3 bus.</td> </tr> </table>	PGM/1	This outputs only the audio on the PGM/1 bus.	PVW/2	This outputs only the audio on the PVW/2 bus.	AUX/3	This outputs only the audio on the AUX/3 bus.
PGM/1	This outputs only the audio on the PGM/1 bus.							
PVW/2	This outputs only the audio on the PVW/2 bus.							
AUX/3	This outputs only the audio on the AUX/3 bus.							
PHONES OUT	PGM/1 , PVW/2, AUX/3							
MASTER OUTPUT								
OUTPUT LEVEL	-INF -10.0dB	This adjusts the volume level for master out (PGM/1 bus).						
OUTPUT MUTE	OFF , ON	This sets the Mute feature on or off. Setting this to "ON" mutes master out (PGM/1 bus).						
EQ Hi	-15.0- 0.0 -15.0dB	This boosts or attenuates the high band.						
EQ Hi FREQ	1.00- 10.0 -20.0kHz	This adjusts the center frequency when changing the tone quality in the high band.						
EQ Mid	-15.0- 0.0 -15.0dB	This boosts or attenuates the middle band.						
EQ Mid FREQ	20.0Hz- 500Hz -20.0kHz	This adjusts the center frequency when changing the tone quality in the middle band.						
EQ Mid Q	0.5- 1.0 -16.0	This adjusts the width of the frequency band when boosting or attenuating the middle band.						
EQ Lo	-15.0- 0.0 -15.0dB	This boosts or attenuates the low band.						
EQ Lo FREQ	20.0- 100 -500Hz	This adjusts the center frequency when changing the tone quality in the low band.						
MB COMP	OFF , ON	<p>This switches the multi-band compressor on and off.</p> <p>Effect This applies separate compressors in the high, midrange, and low frequency bands.</p>						
MB COMP H THLD	-40.0- -20.0 -0.0dB	These set the individual levels that become the thresholds for the high, midrange, and low bands at which the compressor is applied. Compression is applied to audio that exceeds the threshold.						
MB COMP M THLD	-40.0- -16.0 -0.0dB							
MB COMP L THLD	-40.0- -20.0 -0.0dB							
MB COMP H RATIO	1.00:1, 1.12:1, 1.25:1, 1.40:1, 1.60:1, 1.80:1, 2.00:1, 2.50:1, 3.20:1, 4.00:1, 5.60:1, 8.00:1, 16.0:1, INF:1	These set the amount of compression applied in the high, midrange, and low bands. If this is set to "1.00:1," compression is not applied.						
MB COMP M RATIO	The default values are as follows.							
MB COMP L RATIO	MB COMP H RATIO: 3.20:1 MB COMP H RATIO: 2.50:1 MB COMP H RATIO: 3.20:1							
LIMITER	OFF , ON	<p>This sets the limiter on or off.</p> <p>Effect This limits the output volume so that it does not exceed the set level.</p>						
LIMITER THLD	-40.0- -6.0 -0.0dB	This sets the level that becomes the threshold at which the limiter is applied. Compression is applied to audio that exceeds the threshold. The volume level of audio that is output is limited so as to stay below the threshold.						

Menu item	Value (bold text: default value)	Explanation
PVW		
PVW LEVEL	-INF-10.0dB	This adjusts the volume level for PVW/2 bus.
PVW MUTE	OFF, ON	This sets the Mute feature on or off. Setting this to "ON" mutes PVW/2 bus.
EQ Hi	-15.0- 0.0 -15.0dB	This boosts or attenuates the high band.
EQ Hi FREQ	1.00- 10.0 -20.0kHz	This adjusts the center frequency when changing the tone quality in the high band.
EQ Mid	-15.0- 0.0 -15.0dB	This boosts or attenuates the middle band.
EQ Mid FREQ	20.0Hz- 500Hz -20.0kHz	This adjusts the center frequency when changing the tone quality in the middle band.
EQ Mid Q	0.5- 1.0 -16.0	This adjusts the width of the frequency band when boosting or attenuating the middle band.
EQ Lo	-15.0- 0.0 -15.0dB	This boosts or attenuates the low band.
EQ Lo FREQ	20.0- 100 -500Hz	This adjusts the center frequency when changing the tone quality in the low band.
MB COMP	OFF, ON	This switches the multi-band compressor on and off. Effect This applies separate compressors in the high, midrange, and low frequency bands.
MB COMP H THLD	-40.0- -20.0 -0.0dB	These set the individual levels that become the thresholds for the high, midrange, and low bands at which the compressor is applied. Compression is applied to audio that exceeds the threshold.
MB COMP M THLD	-40.0- -16.0 -0.0dB	
MB COMP L THLD	-40.0- -20.0 -0.0dB	
MB COMP H RATIO	1.00:1, 1.12:1, 1.25:1, 1.40:1,	These set the amount of compression applied in the high, midrange, and low bands. If this is set to "1.00:1," compression is not applied.
MB COMP M RATIO	1.60:1, 1.80:1, 2.00:1, 2.50:1,	
MB COMP L RATIO	3.20:1, 4.00:1, 5.60:1, 8.00:1, 16.0:1, INF:1	
MB COMP L RATIO	The default values are as follows. MB COMP H RATIO: 3.20:1 MB COMP M RATIO: 2.50:1 MB COMP L RATIO: 3.20:1	
LIMITER	OFF, ON	This sets the limiter on or off. Effect This limits the output volume so that it does not exceed the set level.
LIMITER THLD	-40.0- -6.0 -0.0dB	This sets the level that becomes the threshold at which the limiter is applied. Compression is applied to audio that exceeds the threshold. The volume level of audio that is output is limited so as to stay below the threshold.
AUX		
AUX LEVEL	-INF- 0.0 -10.0dB	This adjusts the volume level of audio on the AUX/3 bus.
AUX MUTE	OFF, ON	This sets the Mute feature on or off. Setting this to "ON" mutes the AUX/3-bus audio.
LIMITER	OFF, ON	This sets the limiter on or off. Effect This limits the output volume so that it does not exceed the set level.
THRESHOLD	-40.0- -6.0 -0.0dB	This sets the level that becomes the threshold at which the limiter is applied. Compression is applied to audio that exceeds the threshold. The volume level of audio that is output is limited so as to stay below the threshold.

8: AUDIO FOLLOW

Menu item	Value (bold text: default value)	Explanation
SDI IN 1–SDI IN 4 HDMI IN 5, 6	OFF , ON	This switches the Audio Follow feature on or off. Video channels for which this is set to “ON” are automatically muted when video on another channel is output.
AUDIO IN 1– AUDIO IN 5/6	OFF , SDI IN 1–SDI IN 4, HDMI IN 5, HDMI/ANLG IN 6, STL/BKG IN 7, STL/BKG IN 8	This sets the video channel to interlink with input audio using Audio Follow. Audio from AUDIO IN 1–AUDIO IN 5/6 is muted out for video channels other than what you specified. When this is set to “OFF,” no video channels using Audio Follow are assigned.

9: AUDIO EMBEDDED

Menu item	Value (bold text: default value)	Explanation
AUDIO IN 1– AUDIO IN 5/6	OFF , DRY, WET	This specifies the type of input audio sent to the SDI embedded-audio channels (3–8).
		OFF No audio is sent.
		DRY This sends the source audio with no effects applied.
		WET This sends the effect-applied audio.
		The audio shown below is assigned to the respective channels of SDI embedded audio.
		SDI embedded-audio channel number Assigned audio
		Channel 1 The L-channel of the bus
		Channel 2 The R-channel of the bus
		Channel 3 AUDIO IN 1
		Channel 4 AUDIO IN 2
Channel 5 AUDIO IN 3		
Channel 6 AUDIO IN 4		
Channel 7 AUDIO IN 5/L		
Channel 8 AUDIO IN 6/R		
SDI OUT 1 AUDIO	CH1–2 , CH1–8	This specifies the embedded-audio channel that is output via the SDI OUT 1 connector.
SDI OUT 2 AUDIO	CH1–2 , CH1–8	This specifies the embedded-audio channel that is output via the SDI OUT 2 connector.

10: AUDIO AUTO MIXING

Menu item	Value (bold text: default value)	Explanation
AUTO MIXING	OFF , ON	This switches the Auto Mixing feature on or off.
AUDIO IN 1 SW– AUDIO IN 4 SW	OFF, ON	This specifies whether Auto Mixing is applied (ON) or not applied (OFF).
AUDIO IN 5/6 SW SDI IN 1 SW– SDI IN 4 SW HDMI 5 SW HDMI 6 SW	OFF , ON	
AUDIO IN 1 WT– AUDIO IN 5/6 WT SDI IN 1 WT– SDI IN 4 WT HDMI 5 WT HDMI 6 WT	0– 100%	

11: MODE

Menu item	Value (bold text: default value)	Explanation
MODE	PGM-PST	You can select the preset video (the video to be output next) for the PVW/2 bus, and after checking that video, output it to the PGM/1 bus.
	DISSOLVE	You can select the video that you want to output, and immediately output it to the PGM/1 bus.
	MATRIX	You can individually select the video that is output to each bus (PGM/1, PVW/2, AUX/3 buses).

12: PRESET MEMORY

Menu item	Value (bold text: default value)	Explanation								
LOAD (*14)	MEMORY 1 –MEMORY 8	This selects the preset memory to load. Pressing the [VALUE] knob lets you load the preset memory.								
SAVE	MEMORY 1 –MEMORY 8	<p>This selects a preset memory for saving settings. Pressing the [VALUE] knob lets you save the settings to the preset memory.</p> <p>* The state of the [FREEZE] button and [PHONES] knob are not saved to any preset memory. The [FREEZE] button is always dark at startup.</p> <p>* The state of the [SW MODE] button and the settings shown below are saved as global settings for the unit. They are not saved to preset memories.</p> <table border="1"> <thead> <tr> <th>Category</th> <th>Setting items saved in the unit</th> </tr> </thead> <tbody> <tr> <td>REMOTE</td> <td>All setting items except "CAM AF" and "CAM AE" * "CAM AF" and "CAM AE" are always set to "OFF" at startup.</td> </tr> <tr> <td>LAN CONTROL</td> <td>All menu items</td> </tr> <tr> <td>SYSTEM</td> <td>All setting items except "TEST PATTERN" and "TEST TONE" * "TEST PATTERN" and "TEST TONE" are always set to "OFF" at startup.</td> </tr> </tbody> </table>	Category	Setting items saved in the unit	REMOTE	All setting items except "CAM AF" and "CAM AE" * "CAM AF" and "CAM AE" are always set to "OFF" at startup.	LAN CONTROL	All menu items	SYSTEM	All setting items except "TEST PATTERN" and "TEST TONE" * "TEST PATTERN" and "TEST TONE" are always set to "OFF" at startup.
Category	Setting items saved in the unit									
REMOTE	All setting items except "CAM AF" and "CAM AE" * "CAM AF" and "CAM AE" are always set to "OFF" at startup.									
LAN CONTROL	All menu items									
SYSTEM	All setting items except "TEST PATTERN" and "TEST TONE" * "TEST PATTERN" and "TEST TONE" are always set to "OFF" at startup.									
DELETE	MEMORY 1 –MEMORY 8	This selects a preset memory to delete. Pressing the [VALUE] knob lets you delete the preset memory.								
START UP	LAST MEMORY , MEMORY 1–MEMORY 8	<p>This specifies the settings loaded at startup.</p> <table border="1"> <tbody> <tr> <td>LAST MEMORY</td> <td>This restores the state that was in effect immediately before the power was turned off (Last Memory feature). The current settings (Last Memory values) are saved every 4 seconds, and when you exit a menu.</td> </tr> <tr> <td>MEMORY 1–MEMORY 8</td> <td>These recall the settings at the selected memory number.</td> </tr> </tbody> </table>	LAST MEMORY	This restores the state that was in effect immediately before the power was turned off (Last Memory feature). The current settings (Last Memory values) are saved every 4 seconds, and when you exit a menu.	MEMORY 1–MEMORY 8	These recall the settings at the selected memory number.				
LAST MEMORY	This restores the state that was in effect immediately before the power was turned off (Last Memory feature). The current settings (Last Memory values) are saved every 4 seconds, and when you exit a menu.									
MEMORY 1–MEMORY 8	These recall the settings at the selected memory number.									
MEMORY PROTECT	OFF , ON	When this is set to "ON," the preset memories are protected, and settings cannot be saved to them.								

(*14) When the [SW MODE] button is lit in blue, the cross-point (upper row) [1]–[8] buttons function as shortcuts for loading to preset memories.

13: REMOTE

Menu item	Value (bold text: default value)	Explanation
RS-232	OFF , ON	Setting this to "ON" makes it possible to send and receive RS-232 commands.
RS-232 BAUDRATE	9600 , 38400	This sets the communication speed (bps) of the RS-232 connector.
GPI 1 TYPE– GPI 8 TYPE	N/A , PGM CH SEL 1– PGM CH SEL 8, PST CH SEL 1–PST CH SEL 8, MEMORY LOAD 1– MEMORY LOAD 8, DSK SRC SEL 1– DSK SRC SEL 8	This sets the function assigned to the GPI channel. * When a control signal is input from an external source, the assigned function is executed. The GPI trigger is fixed at the trailing edge (low: ON). For details, refer to "Inputting a Control Signal" (p. 25).
		N/A No function is assigned.
		PGM CH SEL 1– PGM CH SEL 8 This switches the final output video.
		PST CH SEL 1– PST CH SEL 8 This switches the preset video (the video to be output next).
		MEMORY LOAD 1– MEMORY LOAD 8 This loads a preset memory.
		DSK SRC SEL 1– DSK SRC SEL 8 During DSK compositing, this switches the channel of the overlaid logo or image.
GPO 1 TYPE– GPO 4 TYPE	ONE SHOT , ALT	This sets the control method that is used when outputting GPO signals to an external device.
		ONE SHOT When you press a cross-point [1]–[4] button, a GPO signal is output for 0.5 seconds.
		ALT Each time you press a cross-point [1]–[4] button, the GPO signal output turns on/off.
RS-422 BAUDRATE	9600 , 38400	This sets the communication speed (bps) of the RS-422 connector.
CAM ID	CAMERA1 –CAMERA7	This selects the remote camera that is operated.
CAM PAN	LEFT, RIGHT	This pans the remote camera. Operation occurs while you hold down the [VALUE] knob.
CAM TILT	DOWN, UP	This tilts the remote camera. Operation occurs while you hold down the [VALUE] knob.
PAN/TILT SPEED	1– 12 –24	This sets the speed of the pan and tilt operations.
CAM ZOOM	IN , OUT	This zooms the remote camera. Operation occurs while you hold down the [VALUE] knob.
CAM FOCUS	FAR , NEAR	This focuses the remote camera. Operation occurs while you hold down the [VALUE] knob. This is available when "CAM AF" is set to "OFF."
CAM AF	OFF, ON	This sets the auto focus function of the remote camera. The default value depends on the settings of the camera that you're using.
CAM BRIGHT	DOWN, UP	This sets the brightness of the remote camera. Operation occurs while you hold down the [VALUE] knob. This is available when "CAM AE" is set to "OFF."
CAM AE	OFF, ON	This sets the auto exposure function of the remote camera. The default value depends on the settings of the camera that you're using.
CAM RECALL	MEMORY1 –MEMORY8	This recalls settings that are saved in the remote camera.
CAM STORE	MEMORY1 –MEMORY8	This saves settings in the remote camera.
CAM RESET	(EXEC)	This resets the connection settings of the remote camera. If remote cameras are connected in a daisy-chain, the ID of each is reassigned starting with the camera that is closest to the XS-62S.

14: LAN CONTROL

Menu item	Value (bold text: default value)	Explanation										
CONFIGURE	MANUALLY, USING DHCP	This sets whether the IP address and subnet mask are obtained automatically (USING DHCP) or set manually (MANUALLY).										
IP ADDRESS (*15)	192.168.2.254	This sets the IP address.										
SUBNET MASK (*15)	255.255.255.0	This sets the subnet mask.										
INFORMATION	(ENTER)	The LAN INFORMATION screen appears.										
		<table border="1"> <thead> <tr> <th>Indication</th> <th>Explanation</th> </tr> </thead> <tbody> <tr> <td>STATUS</td> <td>This displays the connection status.</td> </tr> <tr> <td>IP ADDRESS</td> <td>This displays the IP address.</td> </tr> <tr> <td>SUBNET MASK</td> <td>This displays the subnet mask.</td> </tr> <tr> <td>MAC ADDRESS</td> <td>This displays the MAC address.</td> </tr> </tbody> </table>	Indication	Explanation	STATUS	This displays the connection status.	IP ADDRESS	This displays the IP address.	SUBNET MASK	This displays the subnet mask.	MAC ADDRESS	This displays the MAC address.
		Indication	Explanation									
		STATUS	This displays the connection status.									
		IP ADDRESS	This displays the IP address.									
SUBNET MASK	This displays the subnet mask.											
MAC ADDRESS	This displays the MAC address.											

(*15) This is available when "CONFIGURE" is set to "MANUALLY."

15: USB MEMORY

Menu item	Value (bold text: default value)	Explanation								
LOAD PRESET	(ENTER)	The USB LOAD screen appears. This loads a settings file (.X62) that is on the USB flash drive into the unit.								
SAVE PRESET	(ENTER)	The USB SAVE screen appears. This saves settings, overwriting the selected settings file (.X62) on the USB flash drive.								
SAVE AS PRESET	(ENTER)	The USB SAVE AS screen appears. This newly saves the unit's settings to the USB flash drive as a single file (.X62). * Any still images that have been imported into the unit are not saved in the file.								
LOAD STILL IMAGE	STILL IMAGE 1 , STILL IMAGE 2	<p>When you are importing a still image that is on a USB flash drive, this specifies the memory to use as the destination for saving the image on the unit.</p> <p>Pressing the [VALUE] knob lets you import the still image.</p> <p>A "*" symbol is displayed for memory where a still image is already saved.</p> <p>File format of the still images that can be loaded</p> <table border="1"> <thead> <tr> <th></th> <th>Explanation</th> </tr> </thead> <tbody> <tr> <td>Format</td> <td>Bitmap (.bmp), 24-bit color, uncompressed</td> </tr> <tr> <td>Resolution</td> <td>In conformity with system format</td> </tr> <tr> <td>File name</td> <td>No more than 8 single-byte alphanumeric characters * Be sure to append the ".bmp" file extension.</td> </tr> </tbody> </table>		Explanation	Format	Bitmap (.bmp), 24-bit color, uncompressed	Resolution	In conformity with system format	File name	No more than 8 single-byte alphanumeric characters * Be sure to append the ".bmp" file extension.
	Explanation									
Format	Bitmap (.bmp), 24-bit color, uncompressed									
Resolution	In conformity with system format									
File name	No more than 8 single-byte alphanumeric characters * Be sure to append the ".bmp" file extension.									
FORMAT	(EXEC)	This formats the USB flash drive.								

16: CAPTURE IMAGE

Menu item	Value (bold text: default value)	Explanation
CAPTURE SOURCE	INPUT 1 –INPUT 6	This specifies the input video to use for still-image capture.
TARGET STORAGE NO	STILL IMAGE 1 , STILL IMAGE 2	This selects the memory to use as the destination for saving the captured still image. * A "*" symbol is displayed for memory where a still image is already saved.
CAPTURE EXECUTE	(EXEC)	This captures a still image. * Capture is not possible if the [FREEZE] button is on.

17: SYSTEM

Menu item	Value (bold text: default value)	Explanation														
HDCP	OFF , ON	This specifies whether HDCP is enabled (ON) or disabled (OFF). When set to "ON," copyright-protected (HDCP) video can be input. HDCP is also added to the video that is output. When "HDCP" is set to "ON," no video is output via the SDI OUT connectors.														
FRAME RATE	59.94Hz , 50Hz	This sets the frame rate.														
SYSTEM FORMAT	720p, 1080i , 1080p	This specifies the system format for the XS-62S. The input and output formats of the respective connectors are determined according to the system format, as shown in the table below. <table border="1" data-bbox="644 607 1442 824"> <thead> <tr> <th rowspan="2">System format</th> <th>Input format</th> <th>Output format</th> </tr> <tr> <th>SDI IN 1–SDI IN 4 connectors</th> <th>SDI OUT 1 and 2 connectors HDMI OUT 1 and 2 connectors</th> </tr> </thead> <tbody> <tr> <td>1080p</td> <td>1080p, 1080i</td> <td>1080p</td> </tr> <tr> <td>1080i</td> <td>1080p, 1080i</td> <td>1080i</td> </tr> <tr> <td>720p</td> <td>720p</td> <td>720p</td> </tr> </tbody> </table> <p>The input format of the HDMI IN 5 connector is set independently by the "EDID" value for "HDMI IN 5" (p. 3), regardless of the system format.</p> <p>The input format of the HDMI IN 6 connector or RGB/COMPONENT IN 6 connector is set independently by the "EDID" value for "HDMI/ANLG IN 6" (p. 5), regardless of the system format.</p> <p>* If OUTPUT ASSIGN (p. 5) is set to "MULTI-VIEW" for the HDMI OUT 3 connector, the output format is fixed at "1080p."</p>	System format	Input format	Output format	SDI IN 1–SDI IN 4 connectors	SDI OUT 1 and 2 connectors HDMI OUT 1 and 2 connectors	1080p	1080p, 1080i	1080p	1080i	1080p, 1080i	1080i	720p	720p	720p
System format	Input format	Output format														
	SDI IN 1–SDI IN 4 connectors	SDI OUT 1 and 2 connectors HDMI OUT 1 and 2 connectors														
1080p	1080p, 1080i	1080p														
1080i	1080p, 1080i	1080i														
720p	720p	720p														
AUTO SCAN	OFF , ON	This turns on/off the function that automatically switches the video of channels 1–6.														
AUTO SCAN TIME	1sec– 5sec –120sec	This sets the time (seconds) of the automatic video switching														
MENU CONTEXT	OFF, ON	This turns on/off the function that switches the menu screen according to the controllers that are operated. * The controllers relevant to this function are the AUDIO MIXER [1]–[5/6] knobs, the cross-point [1]–[8] buttons, the [PinP] button, and the [DSK] button.														
TEST PATTERN	OFF , 75% COLOR BAR, 100% COLOR BAR, RAMP, STEP, HATCH	This specifies the test pattern.														
TEST TONE	OFF , -20dB@1kHz, -10dB@1kHz, 0dB@1kHz	This specifies the test tone.														
PANEL OPERATION	PGM/PST , A/B	This sets the operation mode for video transitions.														

Menu item	Value (bold text: default value)	Explanation																																				
PANEL LOCK	(ENTER)	Pressing the [VALUE] knob displays the PANEL LOCK menu items shown below. These specify whether panel lock is applied (ON) or not applied (OFF) for each individual button and knob.																																				
		<table border="1"> <thead> <tr> <th>Menu item</th> <th>Value</th> <th>Explanation</th> </tr> </thead> <tbody> <tr> <td>MENU+EXIT</td> <td>OFF, ON</td> <td>[MENU] and [EXIT] buttons</td> </tr> <tr> <td>VALUE</td> <td>OFF, ON</td> <td>[VALUE] knob</td> </tr> <tr> <td>CROSS POINT</td> <td>OFF, ON</td> <td>Cross-point [1]–[8] buttons * This is valid when the [SW MODE] button is set to PGM/PST (yellow) or AUX (green).</td> </tr> <tr> <td>SW MODE</td> <td>OFF, ON</td> <td>[SW MODE] button</td> </tr> <tr> <td>FREEZE</td> <td>OFF, ON</td> <td>[FREEZE] button</td> </tr> <tr> <td>PinP</td> <td>OFF, ON</td> <td>[PinP] button</td> </tr> <tr> <td>DSK</td> <td>OFF, ON</td> <td>[DSK] button</td> </tr> <tr> <td>TAKE</td> <td>OFF, ON</td> <td>[TAKE] button</td> </tr> <tr> <td>AUTO MIXING SW</td> <td>OFF, ON</td> <td>[AUTO MIXING] button</td> </tr> <tr> <td>CH VOLUME</td> <td>OFF, ON</td> <td>AUDIO MIXER [1]–[5/6] knobs</td> </tr> <tr> <td>MASTER VOLUME</td> <td>OFF, ON</td> <td>[MASTER] knob</td> </tr> </tbody> </table>	Menu item	Value	Explanation	MENU+EXIT	OFF , ON	[MENU] and [EXIT] buttons	VALUE	OFF , ON	[VALUE] knob	CROSS POINT	OFF , ON	Cross-point [1]–[8] buttons * This is valid when the [SW MODE] button is set to PGM/PST (yellow) or AUX (green).	SW MODE	OFF , ON	[SW MODE] button	FREEZE	OFF , ON	[FREEZE] button	PinP	OFF , ON	[PinP] button	DSK	OFF , ON	[DSK] button	TAKE	OFF , ON	[TAKE] button	AUTO MIXING SW	OFF , ON	[AUTO MIXING] button	CH VOLUME	OFF , ON	AUDIO MIXER [1]–[5/6] knobs	MASTER VOLUME	OFF , ON	[MASTER] knob
		Menu item	Value	Explanation																																		
		MENU+EXIT	OFF , ON	[MENU] and [EXIT] buttons																																		
		VALUE	OFF , ON	[VALUE] knob																																		
		CROSS POINT	OFF , ON	Cross-point [1]–[8] buttons * This is valid when the [SW MODE] button is set to PGM/PST (yellow) or AUX (green).																																		
		SW MODE	OFF , ON	[SW MODE] button																																		
		FREEZE	OFF , ON	[FREEZE] button																																		
		PinP	OFF , ON	[PinP] button																																		
		DSK	OFF , ON	[DSK] button																																		
		TAKE	OFF , ON	[TAKE] button																																		
		AUTO MIXING SW	OFF , ON	[AUTO MIXING] button																																		
CH VOLUME	OFF , ON	AUDIO MIXER [1]–[5/6] knobs																																				
MASTER VOLUME	OFF , ON	[MASTER] knob																																				
		Press and hold the [EXIT] button and the [MENU] button at the same time (for 3 seconds or longer) to turn on panel lock. Buttons and knobs for which panel lock is applied (ON) are locked.																																				
LCD BACKLIGHT	OFF, ON	This illuminates (ON) or darkens (OFF) the backlight for the built-in display. If this is set to "AUTO OFF," the backlight of the unit's display automatically goes dark when ten seconds have elapsed without any operation occurring.																																				
LCD CONTRAST	0– 10 –20	This adjusts the contrast for the built-in display.																																				
LED DIMMER	0– 7	This adjusts the brightness of the LEDs. * When this is set to "0," the LEDs are not completely dark.																																				
MULTI-VIEW LABEL (*16)	OFF, ON	When this is set to "ON," labels are displayed on the multi-view monitor.																																				
MULTI-VIEW TALLY (*16)	OFF, ON	When this is set to "ON," a tally border is displayed on the multi-view monitor. An AUX symbol is also displayed for the video channel selected as the video on the AUX bus.																																				
LEVEL METER (*16)	OFF, ON	When this is set to "ON," an audio level meter is displayed on the multi-view monitor. An A.F symbol is also displayed for video channels for which Audio Follow is turned on.																																				
ON SCREEN MENU (*16)	OFF, UPPER LEFT , UPPER RIGHT, LOWER LEFT, LOWER RIGHT	This specifies the location of the OSD menu displayed on the multi-view monitor. When this is set to "OFF," the OSD menu is always hidden.																																				
DELETE STILL	STILL IMAGE 1 , STILL IMAGE 2	This selects the memory whose still image is to be deleted. Pressing the [VALUE] knob lets you delete the still image. A "*" symbol is displayed for memory where a still image is already saved.																																				
AUTO OFF	OFF, ON	This sets the Auto Off function on or off. The power to the XS-62S turns off automatically when all of the following states persist for 240 minutes. No operation performed on the XS-62S No audio or video input No equipment is connected to the HDMI OUT connectors																																				
FACTORY RESET	(EXEC)	This returns the unit to its factory defaults.																																				
VERSION	—	This displays the version of the system program.																																				

(*16) This is valid when the HDMI OUT 3 connector's OUTPUT ASSIGN (p. 5) is set to something other than "MULTI-VIEW."

Control Using the TALLY/GPIO and RS-422 Connector

In addition to tally signal output functionality, control signal input/output functionality is also provided, allowing you to transmit or receive control signals to or from an external device.

Specification of the TALLY/GPI Connector

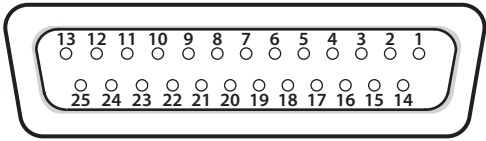
Pin layout		Pin assignments			
 <p>DB-25 type (female)</p>		Pin #	Function	Pin #	Function
		1	TALLY 1 PGM	14	GPO 2
		2	TALLY 1 PST	15	GPO 3
		3	TALLY 2 PGM	16	GPO 4
		4	TALLY 2 PST	17	GND
		5	TALLY 3 PGM	18	GPI 1
		6	TALLY 3 PST	19	GPI 2
		7	TALLY 4 PGM	20	GPI 3
		8	TALLY 4 PST	21	GPI 4
		9	TALLY 5 PGM	22	GPI 5
		10	TALLY 5 PST	23	GPI 6
		11	TALLY 6 PGM	24	GPI 7
		12	TALLY 6 PST	25	GPI 8
		13	GPO 1		

Tally output	
Trigger method	Open collector
Maximum input	12 V/200 mA
Control input	
Trigger method	No-voltage contact (make-contact) triggering
Contact capacity	DC 24 V 0.1 A or higher
Input method	Photocoupler

Inputting a Control Signal

To operate the XS-62S remotely using control-signal input, you first assign the function to a GPI channel (1 through 8).

1. Select the [MENU] button → “REMOTE” → “GPI 1 TYPE” through “GPI 8 TYPE.”

REMOTE	3/27
GPI1 TYPE	N/A
GPI2 TYPE	N/A

2. Use the [VALUE] knob to specify the function to assign to the GPI channel (1 through 8).

Value	Explanation
N/A	No function is assigned.
PGM CH SEL 1–8	This switches the final output video.
PST CH SEL 1–8	This switches the preset video (the video to be output next).
MEMORY LOAD 1–8	This loads a preset memory.
DSK SRC SEL 1–8	During DSK compositing, this switches the channel of the overlaid logo or image.

3. Press the [VALUE] knob to apply the setting.
4. Press the [MENU] button to quit the menu.

When a control signal is input from an external source, the assigned function is executed. The GPI trigger is fixed at the trailing edge (low: ON).

Outputting Tally Signals or Control Signals

Tally signals or GPO control signals can be output from the TALLY/GPIO connector.

Outputting a Tally Signal

A tally signal is output from the connector pin corresponding to the video channel being output, also including video composition and transition effects.

Outputting a GPO Signal

By switching [SW MODE] to GPO/CAMERA mode, you can output control signals by operating cross-point buttons [1]–[4].

1. Select the [MENU] button → “REMOTE” → “GPO 1 TYPE” through “GPO 8 TYPE.”

REMOTE	11/27
GPO1 TYPE	ONE SHOT
GPO2 TYPE	ONE SHOT

2. Use the [VALUE] knob to set the operating mode of the GPO channel.

Value	Explanation
ONE SHOT	When you press a cross-point [1]–[4] button, a GPO signal is output for 0.5 seconds.
ALT	Each time you press a cross-point [1]–[4] button, the GPO signal output turns on/off.

3. Press the [VALUE] knob to apply the setting.
4. Press the [MENU] button to quit the menu.

Remote Control of a VISCA-compatible Video Camera

You can connect a VISCA-compatible video camera to the RS-422 connector on the XS-62S and operate the video camera by remote control.

- * VISCA is sometimes indicated as “standard protocol.”
- * Depending on the specifications of the remote camera, some functionality might be unavailable.
- VISCA is a protocol developed by Sony for controlling a consumer’s camcorder.
- “VISCA” is a trademark of Sony Corporation.

Connecting a Remote Camera

On the XS-62S, you use the RS-422 connector to operate a remote camera.

Connect the pins of the XS-62S’s RS-422 connector and the pins for the remote camera as shown below.

XS-62S		Remote camera
TxD+	————	RxD IN+
TxD-	————	RxD IN-
GND	————	GND
RxD+	————	TxD IN+
RxD-	————	TxD IN-

Connecting Multiple Remote Cameras (Daisy-chain Connection)

The XS-62S supports daisy-chain connections. If the remote cameras also support daisy-chain connections, you can operate up to 7 cameras from a single XS-62S unit. Connect the pins of the RS-422 connector on the XS-62S to the remote cameras as shown below.

XS-62S		Remote camera 1			Remote camera 2			Remote camera 7	
TxD+	————	RxD IN+	TxD OUT+	————	RxD IN+	TxD OUT+	····	RxD IN+	
TxD-	————	RxD IN-	TxD OUT-	————	RxD IN-	TxD OUT-	····	RxD IN-	
GND	————	GND	GND	————	GND	GND	····	GND	
RxD+	————	TxD IN+	RxD OUT+	————	TxD IN+	RxD OUT+	····	TxD IN+	
RxD-	————	TxD IN-	RxD OUT-	————	TxD IN-	RxD OUT-	····	TxD IN-	

RS-422 Connector Specifications

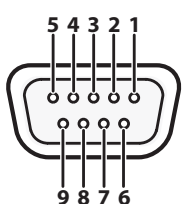
Pin Layout		Pin Assign	
 <p>D-Sub 9-pin (female)</p>		Pin #	Signal name
		1	GND
Transmission method Start-stop synchronization (asynchronous mode), full-duplex		2	TxD+
		3	RxD-
Communication speed (baud rate) 9,600 bps/38,400 bps (Set this according to the status of communication with the remote cameras.)		4	GND
		5	NC
Parity None		6	GND
		7	TxD-
Data length 8-bit		8	RxD+
		9	GND
Stop-bit length 1-bit			
Flow control None			

LAN/RS-232 Command Reference

XS-62S support two types of remote-interface communication: LAN and RS-232.

Using the CONTROL port (LAN) or RS-232 connector to send specific commands to the XS-62S from a controlling device lets you operate the XS-62S remotely.

LAN Interface

This uses the CONTROL port on the XS-62S.

You use Telnet to operate the XS-62S remotely over a LAN (TCP/IP protocol).

Communication standards

Connector	CONTROL port (LAN)
Protocol	TCP
Port number	8023

Setting the IP address of the V-60HD

1. Select the [MENU] button → "LAN CONTROL."
2. Select a menu item, then use the [VALUE] knob to set the IP address.

LAN CONTROL 2/ 4
CONFIGURE
MANUALLY
IP ADDRESS
192.168. 2.254

Menu item	Explanation
CONFIGURE	This sets whether the IP address and subnet mask are obtained automatically (USING DHCP) or set manually (MANUALLY).
IP ADDRESS	This sets the IP address when "CONFIGURE" is set to "MANUALLY." Set this in accordance with the connected network.
SUBNET MASK	This sets the subnet mask when "CONFIGURE" is set to "MANUALLY." Set this in accordance with the connected network.

3. Press the [VALUE] knob to apply the setting.
4. Press the [MENU] button to quit the menu.

Verifying the LAN information

1. Select the [MENU] button → "LAN CONTROL" → "INFORMATION."
2. With the cursor positioned at "ENTER," press the [VALUE] knob.

You can check and verify the following information.

Indication	Explanation
STATUS	This displays the connection status.
IP ADDRESS	This displays the IP address.
SUBNET MASK	This displays the subnet mask.
MAC ADDRESS	This displays the MAC address.

3. Press the [MENU] button to quit the menu.

RS-232 Interface

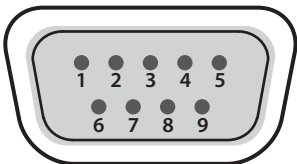
RS-232 connector pin layout	Pin assignments	
	Pin #	Signal
 DB-9 type (male)	1	N.C.
	2	RXD
	3	TXD
	4	DTR
	5	GND
	6	DSR
	7	RTS
	8	CTS
	9	N.C.

Communication standards

Communication method	Synchronous (asynchronous), full-duplex
Communication speed	9600 bps, 38400 bps
Parity	none
Data length	8 bit
Stop bit	1 bit
Code set	ASCII
Flow control	XON/XOFF

Cable wiring diagram

Use an RS-232 crossover cable to connect the XS-62S and the controller (an RS-232-compatible computer or other device).

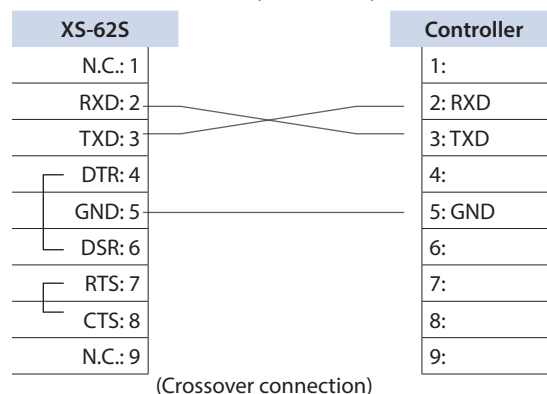

* The connections between 4 and 6 and between 7 and 8 are inside the XS-62S.

Command Format

Commands are formatted using the configuration shown below. Commands are all in ASCII code.

```
stx Command code : Parameter , Parameter ;
```

stx	ASCII code "02H" is a control code indicating the start of a command. "H" indicates that it is a hexadecimal value.
Command code	This specifies the command type (3 letters of the alphabet).
Parameter	This is appended to a command that requires one or more parameter. The command and the parameter portion are separated by a ":" (colon). When there are multiple parameters, they are each separated by "," (comma) characters.
;	This is the code that the XS-62S recognizes as the end of a command.

* The codes of stx (02H), ACK (06H), and XON (11H)/ XOFF (13H) are the control codes.

List of Commands

* When sending a sequence of commands to the XS-62S from a controller, after each one, be sure to verify that an "ACK" response is returned before sending the next command.

Video-related operations

Item	Sent command	Response command	Parameter
Select channel for PGM/1	stxPGM:a;	ACK	a 0 (SDI IN 1), 1 (SDI IN 2), 2 (SDI IN 3), 3 (SDI IN 4), 4 (HDMI IN 5), 5 (HDMI/ANLG IN 6), 6 (STL/BKG IN 7), 7 (STL/BKG IN 8)
Select channel for PVW/2	stxPST:a;	ACK	a: 0 (SDI IN 1), 1 (SDI IN 2), 2 (SDI IN 3), 3 (SDI IN 4), 4 (HDMI IN 5), 5 (HDMI/ANLG IN 6), 6 (STILL/BKG IN 7), 7 (STILL/BKG IN 8)
Select channel for AUX/3	stxAUX:a;	ACK	a 0 (SDI IN 1), 1 (SDI IN 2), 2 (SDI IN 3), 3 (SDI IN 4), 4 (HDMI IN 5), 5 (HDMI/ANLG IN 6), 6 (STILL/BKG IN 7), 7 (STILL/BKG IN 8)
Select transition effect	stxTRS:a;	ACK	a 0 (MIX), 1 (MIX), 2 (WIPE)
Set video transition time	stxTIM:a;	ACK	a 0 (0.0 sec)–40 (4.0 sec)
Use a cut to transition video	stxCUT;	ACK	-
Press the [TAKE] button	stxTAK;	ACK	-
Set the [PinP] button on/off	stxPPS:a;	ACK	a 0 (OFF), 1 (PVW ON), 2 (PGM ON)
Set SPLIT on/off	stxSPS:a;	ACK	a 0 (OFF), 1 (PVW ON), 2 (PGM ON)
Set DSK on/off	stxDSK:a;	ACK	0 (OFF), 1 (ON)
Preview the DSK composited result in the multi-view monitor	stxDVW:a;	ACK	0 (OFF), 1 (ON)
Set the [AUTO MIXING] button on/off	stxATM:a;	ACK	0 (OFF), 1 (ON)
Set the [FREEZE] button on/off	stxFRZ:a;	ACK	0 (OFF), 1 (ON)
Verify the state of a video output channel	stxQVC:a;	strQVC:a,b; ACK	a 0 (PGM/1), 1 (PVW/2), 2 (AUX/3) b 0–7
Set the EDID	stxEDD:a,b;	ACK	a 0 (HDMI IN 5), 1 (HDMI IN 6), 2 (RGB IN 6) b 0 (INTERNAL), 1 (SVGA), 2 (XGA), 3 (WXGA), 4 (FWXGA), 5 (SXGA), 6 (SXGA+), 7 (UXGA), 8 (WUXGA), 9 (720p), 10 (1080i), 11 (1080p) * When a=2 (RGB IN 6), you can select 0–8.
Input scaling type setting	stxVIA:a,b;	ACK	a 0 (HDMI IN 5), 1 (HDMI IN 6), 2 (RGB IN 6) b 0 (FULL), 1 (LETTERBOX), 2 (CROP), 3 (DOT BY DOT), 4 (MANUAL)
Resolution setting for scaler out	stxVOR:a;	ACK	a 0 (480p, 576p), 1 (720p), 2 (1080p), 3 (SVGA), 4 (XGA), 5 (WXGA), 6 (SXGA), 7 (FWXGA), 8 (SXGA+), 9 (UXGA), 10 (WUXGA)
Verify the state of the scaler out resolution	stxQVR;	strQVR:a; ACK	a 0 (480p, 576p), 1 (720p), 2 (1080p), 3 (SVGA), 4 (XGA), 5 (WXGA), 6 (SXGA), 7 (FWXGA), 8 (SXGA+), 9 (UXGA), 10 (WUXGA)
Scaling type of scaler out setting	stxVOA:a;	ACK	a 0 (FULL), 1 (LETTERBOX), 2 (CROP), 3 (DOT BY DOT), 4 (MANUAL)
Select the color space for the HDMI output	stxVOC:a,b;	ACK	a 0 (HDMI OUT 1), 1 (HDMI OUT 2), 2 (HDMI OUT 3) b 0 (YCC), 1 (RGB LMT), 2 (RGB FULL)
Set the signal type for the HDMI output	stxVOD:a,b;	ACK	a 0 (HDMI OUT 1), 1 (HDMI OUT 2), 2 (HDMI OUT 3) b 0 (DVI-D), 1 (HDMI)
When using PinP compositing, adjust the display position of the video	stxPIP:a,b;	ACK	a -450–450 (Horizontal position) b -400–400 (Vertical position)

Item	Sent command	Response command	Parameter
During split composition, adjust the display position of the video	stxSPT:a,b;	ACK	When the split composition pattern is "V-CENTER" This adjusts the display position in the horizontal direction.
			a -250–250 final output video (video on the left)
			b -250–250 preset video (video on the right)
			When the split composition pattern is "H-CENTER" This adjusts the display position in the vertical direction
			a -250–250 final output video (upper video)
			b -250–250 preset video (lower video)
During DSK composition, set the channel of the overlaid logo or image	stxDSS:a;	ACK	a 0 (SDI IN 1), 1 (SDI IN 2), 2 (SDI IN 3), 3 (SDI IN 4), 4 (HDMI IN 5), 5 (HDMI/ANLG IN 6), 6 (STILL/BKG IN 7), 7 (STILL/BKG IN 8)
Adjust the key level (amount of extraction) for DSK composition	stxKYL:a;	ACK	a 0–255
Adjust the key gain (semi-transmissive region) for DSK composition	stxKYG:a;	ACK	a 0–255
Select input connector for channel 6	stxIPS:a;	ACK	a 0 (HDMI), 1 (RGB/COMPONENT)
Query the input connector of video channel 6	stxQIP;	strQIP:a; ACK	a 0 (HDMI), 1 (RGB/COMPONENT), 2 (COMPOSITE)
Set the bus assigned to the video output connector	stxVOS:a;	ACK	a 0 (PGM), 1 (PVW), 2 (AUX)
Query the bus assigned to the video output connector	stxQVS:a;	strQVS:a,b; ACK	a 0 (SDI OUT 1), 1 (SDI OUT 2), 2 (HDMI OUT 1), 3 (HDMI OUT 2), 4 (HDMI OUT 3)
			b 0 (PGM), 1 (PVW), 2 (AUX), 3 (MULTI-VIEW, HDMI OUT 3 only)

Audio-related operations

Item	Sent command	Response command	Parameter
Adjust input volume level for PGM/1 bus audio	stxIL1:a,b;	ACK	a 0 (AUDIO IN 1), 1 (AUDIO IN 2), 2 (AUDIO IN 3), 3 (AUDIO IN 4), 4 (AUDIO IN 5/6), 5 (SDI IN 1), 6 (SDI IN 2), 7 (SDI IN 3), 8 (SDI IN 4), 9 (HDMI IN 5), 10 (HDMI IN 6)
			b -801 (-INF dB), -800 (-80.0dB)–0 (0.0dB)–100 (10.0dB)
Adjust input volume level for PVW/2 bus audio	stxIL2:a;	ACK	a 0 (AUDIO IN 1), 1 (AUDIO IN 2), 2 (AUDIO IN 3), 3 (AUDIO IN 4), 4 (AUDIO IN 5/6), 5 (SDI IN 1), 6 (SDI IN 2), 7 (SDI IN 3), 8 (SDI IN 4), 9 (HDMI IN 5), 10 (HDMI IN 6)
			b -801 (-INF dB), -800 (-80.0dB)–0 (0.0dB)–100 (10.0dB)
Adjust output volume level for master out	stxOL1:a;	ACK	-801 (-INF dB), -800 (-80.0dB)–0 (0.0dB)–100 (10.0dB)
Adjust output volume level for PVW/2 bus audio	stxOL2:a;	ACK	a -801 (-INF dB), -800 (-80.0dB)–0 (0.0dB)–100 (10.0dB)
Adjust output volume level for AUX/3 bus audio	stxOL3:a;	ACK	a -801 (-INF dB), -800 (-80.0dB)–0 (0.0dB)–100 (10.0dB)
Adjust delay time of input audio	stxADT:a,b;	ACK	a 0 (AUDIO IN 1), 1 (AUDIO IN 2), 2 (AUDIO IN 3), 3 (AUDIO IN 4), 4 (AUDIO IN 5/6)
			b 0 (0.0 fps)–120 (12.0 fps)
Acquire information on volume level	stxQAL:a;	stxQAL:b; ACK	a 0 (AUDIO IN 1), 1 (AUDIO IN 2), 2 (AUDIO IN 3), 3 (AUDIO IN 4), 4 (AUDIO IN 5/6), 5 (SDI IN 1), 6 (SDI IN 2), 7 (SDI IN 3), 8 (SDI IN 4), 9 (HDMI IN 5), 10 (HDMI IN 6), 11 (MASTER OUT), 12 (PVW/2), 13 (AUX/3), 14 (ALL)
			b -801 (-INF dB), -800 (-80.0dB)–0 (0.0dB)–100 (10.0dB) When a=14, sends all volume levels. Example: -801, 80, 70, 60, 50, 40, 30, 20, 100, 80, 70, 60, 50;
Assign the bus for an audio output connector	stxAOS:a,b;	ACK	a 0 (AUDIO OUT XLR), 1 (AUDIO OUT RCA), 2 (PHONES)
			b 0 (PGM/1), 1 (PVW/2), 2 (AUX/3)

Item	Sent command	Response command		Parameter
Query the state of the bus for an audio output connector	stxQAS:a;	strQAS:a,b; ACK	a	0 (AUDIO OUT XLR), 1 (AUDIO OUT RCA), 2 (PHONES)
			b	0 (PGM/1), 1 (PVW/2), 2 (AUX/3)

System-related operations

Item	Sent command	Response command		Parameter
Set HDCP on/off	stxHCP:a;	ACK	a	0 (OFF), 1 (ON)
Call up preset memory	stxMEM:a;	ACK	a	0 (1), 1 (2), 2 (3), 3 (4), 4 (5), 5 (6), 6 (7), 7 (8)
GPO output	stxGPO:a,b;	ACK	a	0 (GPO1), 1 (GPO2), 2 (GPO3), 3 (GPO4)
			b	0 (OFF), 1 (ON, This is available when "GPO 1-4 TYPE" is set to "ALT.")
Operation mode for video transition	stxMOD:a;	ACK	a	0 (PGM-PST), 1 (DISSOLVE), 2 (MATRIX)
Camera control	stxCAM:a,b;	ACK	a	0-6 (ID)
			b	0 (MEMORY1), 1 (MEMORY2), 2 (MEMORY3), 3 (MEMORY4), 4 (MEMORY5), 5 (MEMORY6), 6 (MEMORY7), 7 (MEMORY8)
Version information	stxVER;	strVER;a; ACK	a	(The version info is ASCII text strings.)
Acquire status of XS-62S	stxACS;	ACK		-

Commands spontaneously sent from the XS-62S

Item	Sent command	Response command		Parameter
Error detected	-	stxERR:a;	a	0 (syntax error, The received command contains an error.) 4 (invalid, This has no effect because it is controlled by another setting.) 5 (out of range error, An argument of the received command is out of range.)
Flow control	XON	-		-
Flow control	XOFF	-		-

Limitations in each Operating Mode

Depending on the video switching operation mode, there are limitations on the video and audio that can be output, and on the operations that can be performed.

Output Video Buses and Audio Buses

Item \ Operation mode	PGM-PST	DISSOLVE	MATRIX
Output PGM/1 video bus	✓	✓	✓
Output PVW/2 video bus	✓	The same video as the PGM/1 bus is output.	✓
Output AUX/3 video bus	✓	✓	✓
Output PGM/1 audio bus	✓	✓	✓
Output PVW/2 audio bus	The input/output levels are linked with the PGM/1 bus.	The same audio as the PGM/1 bus is output.	✓
Output AUX/3 audio bus	✓	✓	✓

Operation Panel

Item \ Operation mode	PGM-PST	DISSOLVE	MATRIX
Composition (PinP, SPLIT)	✓	✓	-
DSK	✓	✓	-
Video transition (mix, wipe)	✓	✓	Transition by fade-to-black.

Video-related commands

Item	Operation mode Sent command	PGM-PST	DISSOLVE	MATRIX
Select channel for PGM/1	stxPGM:a;	✓	Immediately transits the video when the preset video channel is selected.	Transition by fade-to-black.
Select channel for PVW/2	stxPST:a;	✓	Returns an error (strERR:4;).	Transition by fade-to-black.
Select channel for AUX/3	stxAUX:a;	✓	✓	Transition by fade-to-black.
Select transition effect	stxTRS:a;	✓	✓	Transition by cut or by fade-to-black.
Set video transition time	stxTIM:a;	✓	✓	This sets the fade-to-black time.
Use a cut to transition video	stxCUT;	✓	Returns an error (strERR:4;).	Returns an error (strERR:4;).
Press the [TAKE] button	stxTAK;	✓	Returns an error (strERR:4;).	Returns an error (strERR:4;).
Set the [PinP] button on/off	stxPPS:a;	✓	✓	Returns an error (strERR:4;).
Set SPLIT on/off	stxSPS:a;	✓	✓	Returns an error (strERR:4;).
Set DSK on/off	stxDSK:a;	✓	✓	Returns an error (strERR:4;).
Preview the DSK composited result in the multi-view monitor	stxDVW:a;	✓	✓	Returns an error (strERR:4;).
Set the [AUTO MIXING] button on/off	stxATM:a;	✓	✓	✓
Set the [FREEZE] button on/off	stxFRZ:a;	✓	✓	✓
Verify the state of a video output channel	stxQVC:a;	✓	✓	✓

Item	Operation mode		PGM-PST	DISSOLVE	MATRIX
	Sent command				
Set the EDID	stxEED:a,b;		✓	✓	✓
Input scaling type setting	stxVIA:a,b;		✓	✓	✓
Resolution setting for scaler out	stxVOR:a;		✓	✓	✓
			* Returns an error (strERR:4;) if the HDMI OUT 3 connector's "OUTPUT ASSIGN" (p. 5) is set to "MULTI-VIEW."		
Verify the state of the scaler out resolution	stxQVR;		✓	✓	✓
			* Returns an error (strERR:4;) if the HDMI OUT 3 connector's "OUTPUT ASSIGN" (p. 5) is set to "MULTI-VIEW."		
Scaling type of scaler out setting	stxVOA:a;		✓	✓	✓
Select the color space for the HDMI output	stxVOC:a,b;		✓	✓	✓
Set the signal type for the HDMI output	stxVOD:a,b;		✓	✓	✓
When using PinP compositing, adjust the display position of the video	stxPIP:a,b;		✓	✓	Returns an error (strERR:4;).
When using SPLIT compositing, adjust the display position of the video	stxSPT:a,b;		✓	✓	Returns an error (strERR:4;).
When using DSK compositing, set the channel of the layered text or images	stxDSS:a;		✓	✓	Returns an error (strERR:4;).
Adjust the degree of extraction (transparency) for the key	stxKYL:a;		✓	✓	Returns an error (strERR:4;).
Adjust the degree of edge blur (semi-transmissive region) for the key	stxKYG:a;		✓	✓	Returns an error (strERR:4;).
Select the input connector for video channel 6	stxIPS:a;		✓	✓	✓
Query the state of the input connector for video channel 6	stxQIP;		✓	✓	✓
Assign the bus for a video output connector	stxVOS:a,b;		✓	✓	✓
Query the state of the bus for a video output connector	stxQVS:a;		✓	✓	✓

Audio-related commands

Item	Operation mode		PGM-PST	DISSOLVE	MATRIX
	Sent command				
Adjust input volume level for PGM/1 bus	stxIL1:a,b;		✓	✓	✓
Adjust input volume level for PVW/2 bus	stxIL2:a,b;		The input level of the PGM/1 bus is also adjusted simultaneously.	Returns an error (strERR:4;).	✓
Adjust volume level for master out	stxOL1:a;		✓	✓	✓
Adjust volume level for PVW/2 bus	stxOL2:a;		The input level of the PGM/1 bus is also adjusted simultaneously.	Returns an error (strERR:4;).	✓
Adjust volume level for AUX/3 bus	stxOL3:a;		✓	✓	✓
Adjust delay time of input audio	stxADT:a,b;		✓	✓	✓
Acquire information on volume level	stxQAL:a;		✓	✓	✓
			* The master out's audio level (a:11) and the PVW/2 bus audio level (a:12) will be the same value.		

Item	Operation mode	PGM-PST	DISSOLVE	MATRIX
	Sent command			
Assign the bus for an audio output connector	stxAOS:a,b;	✓	✓	✓
Query the state of the bus for an audio output connector	stxQAS:a;	✓	✓	✓

System-related commands

Item	Operation mode	↻GM-PST	DISSOLVE	MATRIX
	Sent command			
Set HDCP on/off	stxHCP:a;	✓	✓	✓
Call up preset memory	stxMEM:a;	✓	✓	✓
* Returns an error (strERR:5;) if an unsaved memory is recalled.				
GPO output	stxGPO:a,b;	✓	✓	✓
Operation mode for video transition	stxMOD:a;	✓	✓	✓
Camera control	stxCAM:a,b;	✓	✓	✓
Version information	stxVER;	✓	✓	✓
Acquire status of XS-62S	stxACS;	✓	✓	✓

Commands spontaneously sent from the XS-62S

Item	Operation mode	PGM-PST	DISSOLVE	MATRIX
	Sent command			
Error detected		✓	✓	✓
Flow control	stxXON;	✓	✓	✓
Flow control	stxXOFF;	✓	✓	✓

