

HIGH END SYSTEMS

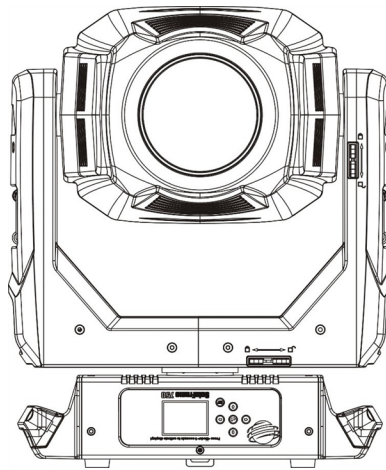

an **ETC.** Company



SolaFrame 750

Professional Moving Head User Manual

Version 1.0.0 --- Revision A

Notice

ETC® and High End Systems® are registered trademarks of Electronic Theatre Controls, Inc. ETC is registered in the United States, China, the European Union, the Madrid Protocol, and Russia. High End Systems is registered in the United States and is pending registration in the European Union, the United Kingdom, and the Madrid Protocol. The High End Systems globe logo is pending registration in the United States, the European Union, and China.

All other trademarks, both marked and not marked, are the property of their respective owners.

Information and specifications in this document are subject to change without notice. High End Systems assumes no responsibility or liability for any errors or inaccuracies that may appear in this manual.

Contents

Welcome	1
Contacting High End Systems	2
FCC Information	5
Patents	6
Terms and Conditions and Warranty Information	6
Product Modification Warning	6
Important Safety Information	7
Fixture Overview	8
Features	9
Optical	9
Mechanical	9
Colors	9
Projection	9
Display	9
Software	10
Additional	10
Safety Considerations	11
General Operation and Use Guidelines	12
Installation Instructions	13
Attachment Instructions	13
Dimensional Drawings	15
Mounting	16
Technical Specifications	17
DMX Control	19
DMX Connector Pinout	19
Terminate DMX512	19
Connect DMX Cables to Fixture	20
DMX Start Address	21
Menu Navigation and Overview	22
Navigation	22
Menu Settings and Programming	23
Current Time	24
Ttl Life Hrs	24
Last Run Hrs	25
LED Hours	25
Timer PIN	25
Clr Last Run	25
LED Time PIN	25
Clear LED Time	26
No DMX Mode	28

Pan Reverse	29
Tilt Reverse	29
Pan Degree	29
Encoders	29
Pan/Tilt Spd	30
Hibernation - Standby mode	30
Defogger	30
Service PIN	31
RDM UID	31
Ethernet IP	31
Ether MaskIP (Subnet Mask)	32
Clr Err Info	32
Shutoff Time	32
Flip Display	33
Key Lock	33
DMX Control Protocol	39
Error Codes	44
Cleaning and Maintenance	47

Welcome

Congratulations on your purchase of the SolaFrame 750 automated framing fixture. The SolaFrame 750 features a compact footprint and a huge feature set that is a perfect fit for smaller to medium-sized venues.

- Small footprint, powerful output
- Four full-curtain framing shutters
- 6°-50° Zoom
- Rotating Gobo Wheel
- Fully-continuous Animation Wheel
- CMY/CTO- linear color mixing
- Replaceable Color Wheel
- Iris, Three-facet Prism, Frost
- Three active cooling modes

This manual provides important information for installation, configuration, and maintenance of your SolaFrame 750. Related reference documentation is available for download from the website: highend.com.

Contacting High End Systems

High End Systems, Inc. is an ETC company.

Headquarters

For Customer Service or Sales support, please contact our company headquarters:

2105 Gracy Farms Lane

Austin, TX 78758 USA

tel: 512.836.2242

fax: 512.837.5290

Toll Free: 800.890.8989

website: highend.com

Technical Support

If you are having difficulties installing, configuring, or operating your SolaFrame 750, your most convenient resources are the references given in this manual. To search more widely, try the High End Systems, Inc. website at highend.com.

24 hour emergency support is available. Contact High End Technical Services at +1 (512)836-2242.



Declaration of Conformity

Manufacturer's name: HAO YEANG ELECTRONIC CO., LTD
Manufacturer's address: No. 109, HaiYong Road, GuanNanYoung Industry Districe, Shiji Town
DanYu Zone, GuanZhou City, China

Distributor's name: High End Systems, Inc.
Distributor's address: 2105 Gracy Farms Lane
Austin, Texas 78758 USA

Product Name: SOLAFRAME 750
Product Options: All

We hereby declare that the above referenced product complies with the essential requirements of Council Directives 2014/30/EU (EMC), 2014/35/EU (LVD) and 2011/65/EC (RoHS) .

Safety: EN 60598-1: 2015
EN 60598-2-17: 1989 A2: 1991
EN62493 (2015)
EN62471 (2008)
EN61347-2-13: 2014;
EN61347-1: 2015
EN62031: 2008+A1; 2013+A2: 2015

EMC: Emission: EN55015:20013+A1:2015,
EN61547:2009
EN 61000-3-2 (2014)
EN 61000-3-3 (2013)

ROHS:	Restricted Substances	Maximum Concentration Value (by weight in homogeneous material)
	Cadmium (Cd)	0.01%
	Lead (Pb)	0.1%
	Mercury (Hg)	0.1%
	Hexavalent Chromium (Cr VI)	0.1%
	Polybrominated Biphenyl (PBB)	0.1%
	Polybrominated Diphenyl Ethers (PBDE)	0.1%

Kenneth S. Hansen



Compliance Engineer

July 10 2017

FCC Information

This equipment has been tested and found to comply with the limits for a Class A digital device, pursuant to part 15 of the FCC rules. These limits are designed to provide reasonable protection against harmful interference when the equipment is operated in a commercial environment. This equipment generates, uses, and can radiate radio frequency energy and, if not installed and used in accordance with the instruction manual, may cause harmful interference to radio communications. Operation of this equipment in a residential area is likely to cause harmful interference, in which case the user will be required to correct the interference at his own expense.

Patents

NOTICE OF INTELLECTUAL PROPERTY RIGHTS

High End Systems, Inc. products are protected by one or more patents listed on the High End Systems, Inc. website: <https://www.highend.com/patents> and/or are subject to one or more pending patents.

Terms and Conditions and Warranty Information

Complete terms and conditions and warranty information can be found on the High End Systems, Inc. website <https://www.highend.com/pub/products/HES-Warranty-Information.pdf>.

Product Modification Warning

High End Systems products are designed and manufactured to meet the requirements of the United States and International safety regulations. Modifications to the product could affect safety and render the product non-compliant to relevant safety standards.

Mise En Garde Contre La Modification Du Produit

Les produits High End Systems sont conçus et fabriqués conformément aux exigences de règlements internationaux de sécurité. Toute modification du produit peut entraîner sa non conformité aux normes de sécurité en vigueur.

Produktmodifikationswarnung

Design und Herstellung von High End Systems entsprechen den Anforderungen der U.S. Amerikanischen und internationalen Sicherheitsvorschriften. Abänderungen dieses Produktes können dessen Sicherheit beeinträchtigen und unter Umständen gegen die diesbezüglichen Sicherheitsnormen verstoßen.

Avvertenza Sulla Modifica Del Prodotto

I prodotti di High End Systems sono stati progettati e fabbricati per soddisfare i requisiti delle normative di sicurezza statunitensi ed internazionali. Qualsiasi modifica al prodotto potrebbe pregiudicare la sicurezza e rendere il prodotto non conforme agli standard di sicurezza pertinenti.

Advertencia De Modificación Del Producto

Los productos de High End Systems están diseñados y fabricados para cumplir los requisitos de las regulaciones de seguridad de los Estados Unidos e internacionales. Las modificaciones al producto podrían afectar la seguridad y dejar al producto fuera de conformidad con las normas de seguridad relevantes.

Important Safety Information

Please read all instructions prior to assembling, mounting, and operating this equipment. Continued and safe operation of this fixture is the responsibility of the operator. This manual will give tips for that continued safe operation. At any time please contact High End Systems technical support for any safety concerns.

The following international note, caution, and warning symbols appear in margins throughout this manual to highlight important messages.



Note: Notes are helpful hints and information that is supplemental to the main text.



CAUTION: A Caution statement indicates situations where there may be undefined or unwanted consequences of an action, potential for data loss or an equipment problem.



CAUTION: This statement indicates that while operating, equipment surfaces may reach very high temperatures. Allow the fixture to cool before handling or servicing.



WARNING: A Warning statement indicates situations where damage may occur, people may be harmed, or there are serious or dangerous consequences of an action.



WARNING: RISK OF ELECTRIC SHOCK! This warning statement indicates situations where there is a risk of electric shock.

Fixture Overview

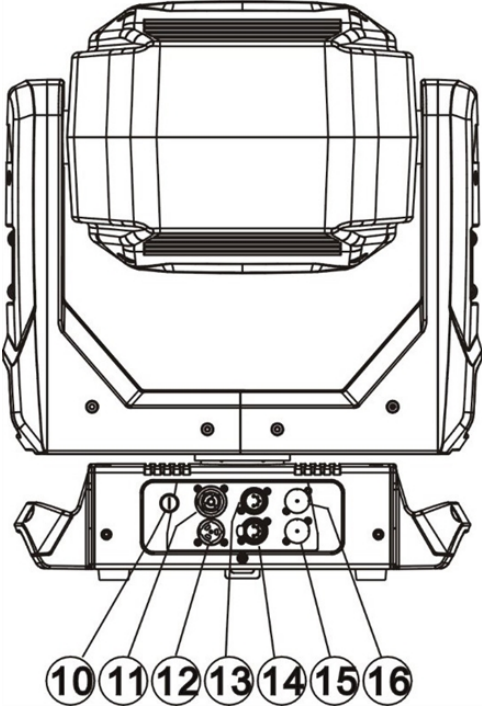
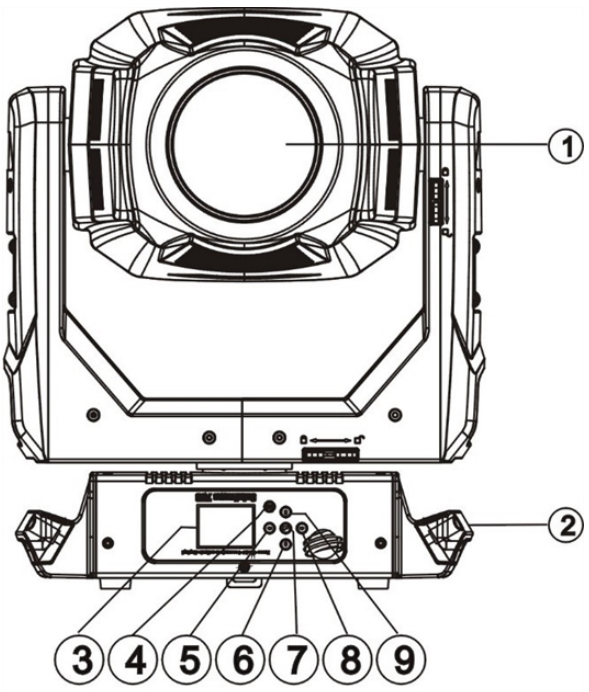

1: Lens
2: Handle
3: Display
4: [MODE/ESC] button
5: Left-button
6: Down-button
7: [Enter] button
8: Right-button
9: Up-button
10: Fuse
11: Power out
12: Power in
13: 5-Pin DMX out
14: 5-Pin DMX in
15: ART-NET in
16: ART-NET out

Features

Optical

- LED: White 270 Watts
- Extremely long Life: >50,000 hours
- Color temperature: 7000 Kelvin
- Luminous flux: 11,300 lumens
- CRI of greater than 70
- Beam angle: Zoom from 6 to 50 degrees
- Strobe effect 1-25 HZ and pulse effect
- Motorized focus
- Dimmer: 0% - 100% full range dimming

Mechanical

- Pan and tilt motion with 8 or 16 bit control resolution
- Smooth, precise mechanical movement system supporting:
 - Pan: 540° (630° optional)
 - Tilt: 265°
 - Variable speed pan and tilt motion
- Position memory, auto correction if fixture is bumped



Colors

- CMY & CTO variable color mixing for infinite color possibilities
- Color wheel including seven interchangeable dichroic filters + open, indexed, rainbow effect

Projection

- Rotating gobo wheel: including seven interchangeable rotating, and indexed, gobo + open
 - "Slot in & out" gobo wheel system
- Rotating prism
- Stepless iris , 5% - 100% linear change iris, pulse iris effect
- Stepless frost, 0% - 100% linear change frost
- Animation wheel: special dynamic flame or water effects

Display

- Advanced full color LCD screen
- Internal rechargeable battery, enable users to access menu for address modification or other settings.
- Automatic lock out after 15 seconds (to prevent unintentional modifications)
- Convenient position reset operation: hold the left-button  and right-button  (Complete this position reset while the fixture is inside the flight case)

Software

- Firmware upgrades are accomplished using a DMX cable with available hardware uploader
- Modify the DMX address, as well as other compatible features, using RDM control
- Standalone operation with Master / Slave function
- Control channel modes: 47 channels

Additional

- Input signal isolation: guarantees stable signal transmission without interference
- Advanced RDM function
- Patented lens defogger

Zoom Range and Distance

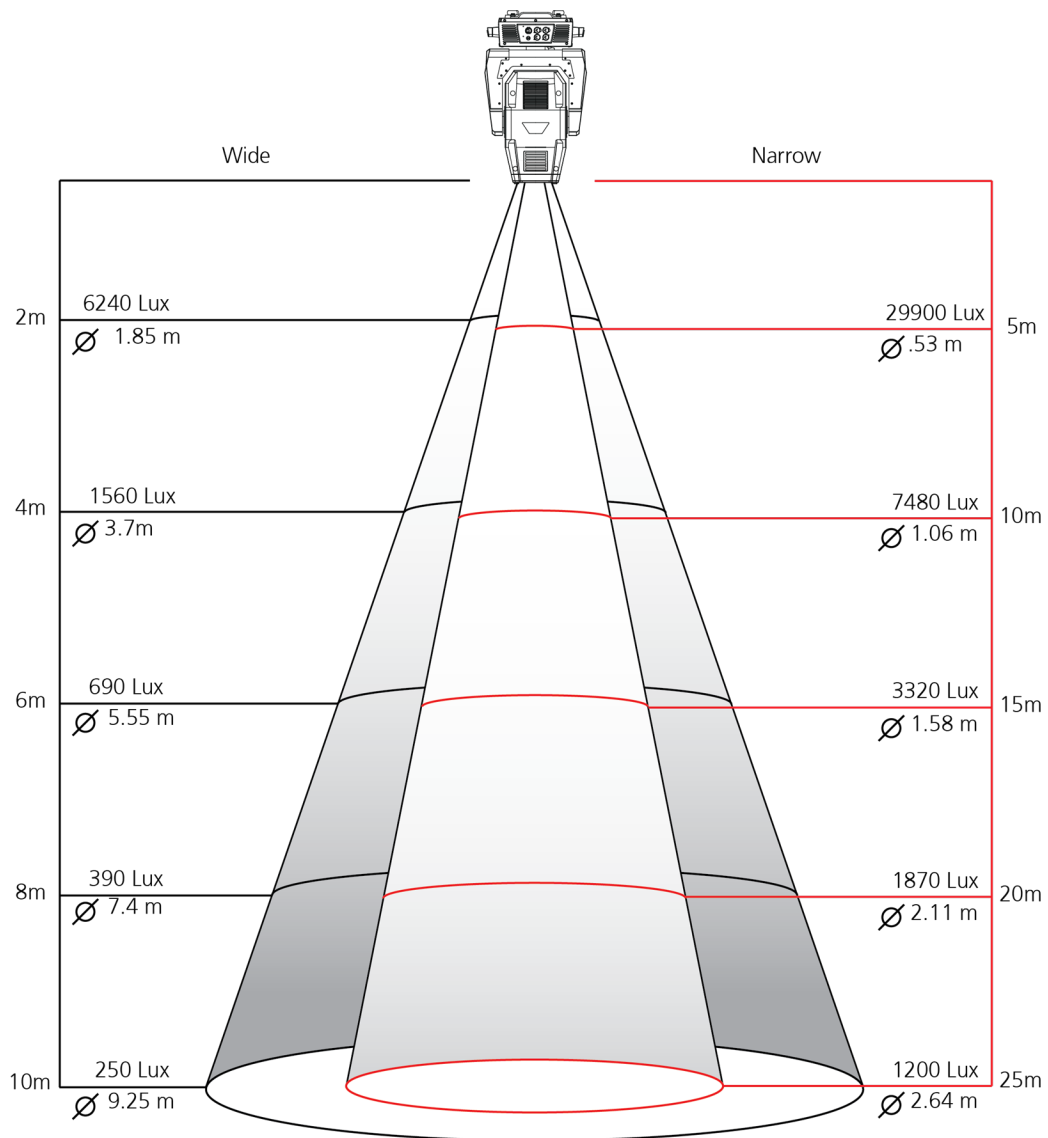

Safety Considerations

This fixture has left the factory in perfect condition. In order to maintain this condition and to ensure safe operation, it is necessary for the user to follow the safety instructions and warning notes written in this user manual and otherwise instructed by the manufacturer representative.

- The SolaFrame 750 fixture is intended for professional use only. Not for residential use. Read the entire manual before using this equipment.
- The SolaFrame 750 fixture is not user serviceable. Field modifications of the unit will void your warranty.



WARNING: For your safety, read the following warnings and notices before use:

- Disconnect the unit from power and DMX before servicing.
- Replace fuses with the specified type and rating only.
- Do not mount the fixture on or near flammable surfaces.
- NEMA Type 1 Enclosure, indoor use, dry locations only. Do not use outdoors. This fixture is intended for use where humidity does not exceed 90% (non-condensing).
- This equipment is designed for operation by qualified personnel only.
- Do not use this fixture with a damaged power lead (cord set). If the lead is damaged, it must be replaced with an equivalent type before use. Contact your local authorized dealer for spare power leads.
- Do not use this fixture if the lens is damaged. Damaged lenses must be replaced before use. Contact your local authorized dealer for a replacement.
- When the fixture has been stored or transported in cold temperatures, allow it to warm to room temperature for a minimum of one hour before applying power. Applying power to a cold fixture will cause damage to the fixture and void the manufacturer warranty.



CAUTION: Hot Surfaces. Allow the fixture to cool completely before handling and servicing.



CAUTION: Damages caused by the disregard of this user manual are not subject to warranty. The authorized dealer will not accept liability for any resulting defects or problems.

General Operation and Use Guidelines

- This fixture is only allowed to be operated with the maximum alternating current which is stated in the technical specifications label provided on the fixture and can be found in the [Technical Specifications on page 17](#)
- Lighting effects are not designed for permanent operation. Consistent operation breaks may ensure that the device will serve you for a long time without defects.
- Do not shake the device. Avoid brute force when installing or operating the device.
- While choosing the installation location, please make sure that the device is not exposed to extreme heat, moisture or dust.
- If you use the Omega bracket with quick lock cam in hanging the fixture, please make sure the quick lock fasteners are turned in the quick lock holes correctly.
- Operate the fixture only after having familiarized yourself with its functions. Do not permit other persons who are not qualified and familiar with its functions to operate the fixture. Most damages are the result of unprofessional operation.
- Please use the original packaging if the device is to be transported. ETC and High End Systems, Inc. will not be responsible for the unit if packaging other than manufacturer provided packaging is used.
- For safety reasons, please be aware that all modifications on the device are forbidden. Any modifications will void the manufacturer warranty.
- This manual describes the proper installation and operation of this fixture. Using this fixture in any way other than the intended use may cause damage and may void the factory warranty.
- Misuse of this fixture, using it in a way different to the methods described in this manual, may lead to personal injury and / or equipment failure.

Installation Instructions

- The installation must always be secured with a secondary safety attachment. An appropriate safety cable is supplied.
- A safety factor of 10:1 shall be required when fixtures are hung
- Use of third party clamps are permitted, but they should comply with the local jurisdiction and be approved by the Authority Having Jurisdiction.
- A supportive and stable surface must be used when the fixtures are placed on the feet.
- The operating temperature range for this fixture is 0 - 45 degrees Celsius. Do not operate the fixture outside of this range.
- Never stand directly below the installed fixture when mounting, removing, or servicing.
- All safety and technical aspects of fixture installation shall be approved by a qualified person before operation.
- The installation must be regularly inspected by a qualified person.
- Overhead rigging must be performed by qualified personnel.

Attachment Instructions

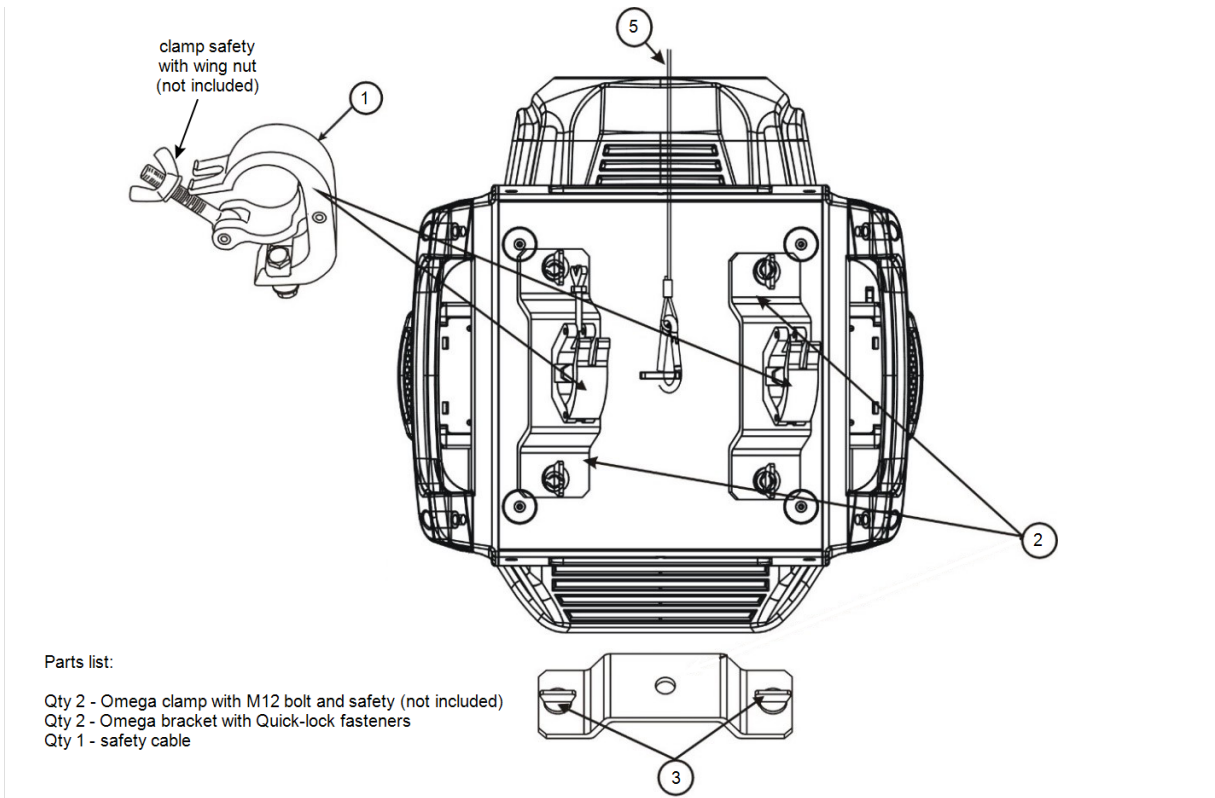

CAUTION: Follow all local codes and recommended practices by the Authority Having Jurisdiction (AHJ). The installation must only be carried out by a qualified person.

1. Assemble the third party clamp or Omega clamp to the Omega bracket and secure together using appropriately sized hardware (not provided).
2. Align the assembled Omega bracket and quick lock fasteners into the respective holes on the bottom of the fixture upper enclosure.
3. Tighten each of the quick lock fasteners fully, turning clockwise. You will hear and feel a click when the fastener is fully secured.
4. Repeat steps 1 through 3 for the second clamp and bracket.
5. Attach the provided safety cable through the attachment point on the bottom of the fixture upper enclosure and secure to the trussing system or other safe installation point. Follow local codes and recommended safety standards for securing the fixture to the installation location.
6. Attach the fixture to the installation location using the installed clamps, using the clamp manufacturers instructions for a secure fit. When using the Omega clamp, close the safety and fully tighten the clamp wing nut until secure.
7. Inspect the installation prior to lifting the fixture over head.

Dimensional Drawings

Dimensions shown are listed as mm [in].

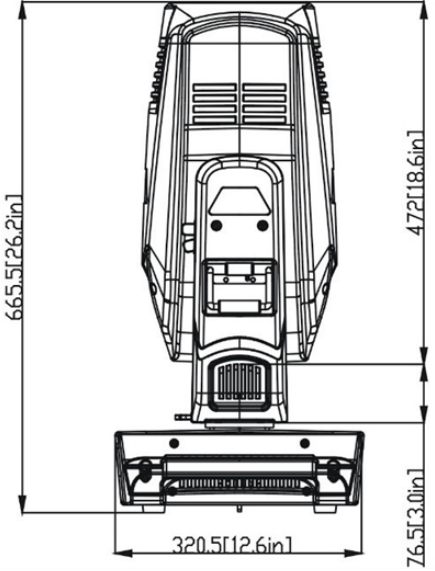
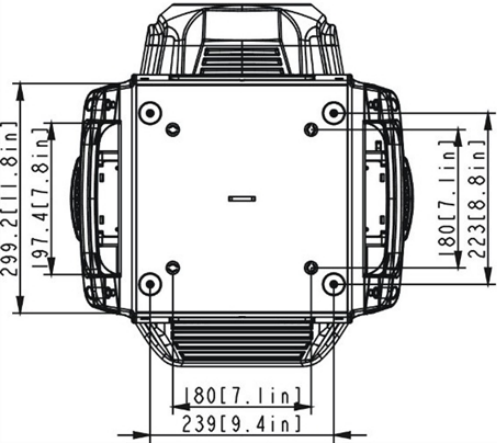
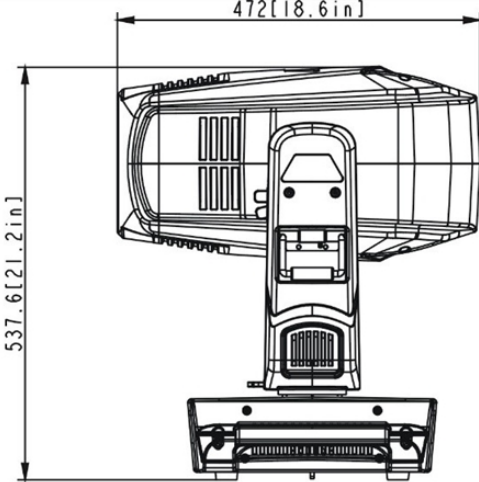
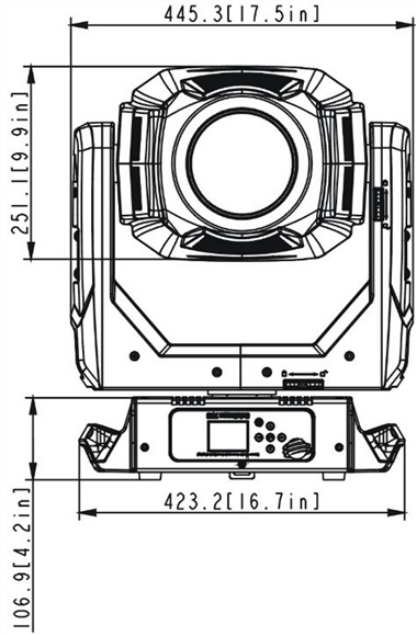

Mounting

Overhead mounting requires extensive experience, including but not limited to:

- calculating working load limits
- knowledge of the installation material being used
- periodic safety inspection of all installation material and the fixture



CAUTION: If you are not qualified, do not attempt the installation yourself. Improper installation can result in bodily injury.



Note: Always use and install the supplied safety cable as a safety measure to prevent accidental damage and/or injury in the event the clamp is improperly installed or fails.



Note: Do not mount the fixture on or near a flammable surface.

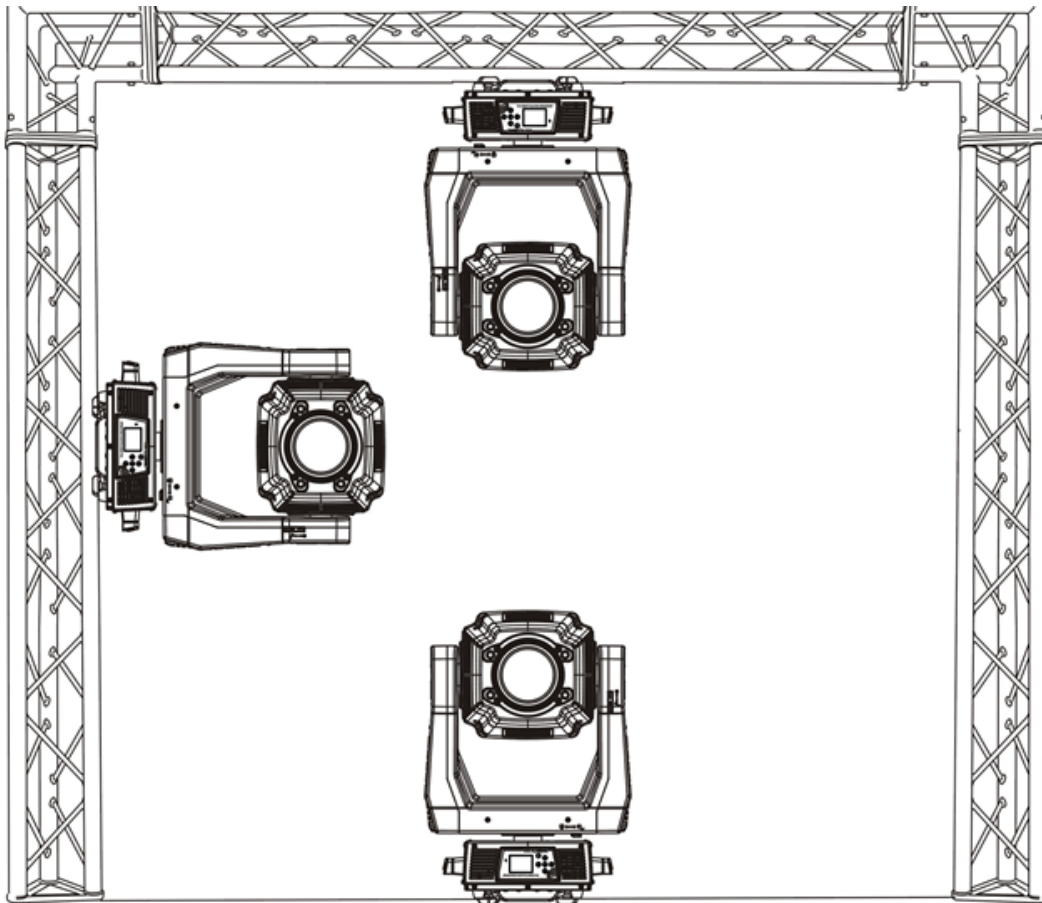

Technical Specifications

Electrical

- Input power rating - 100-240 VAC, 50/60 Hz

SolaFrame 750 Power Factor						
E (VAC)	I (A)	F (Hz)	P (W)	VA	PF	Crest Factor
100	5.619	50	562	0.578	0.99	1.49
120	4.519	60	542	0.558	0.99	1.52
200	2.7	50	540	0.531	0.98	1.54
208	2.558	60	532	0.539	0.98	1.54
220	2.43	50	535	0.536	0.98	1.54
240	2.264	60	543	0.537	0.98	1.51

- Maximum power consumption: 562 W
- 33 dBA - full intensity, static position

Dimensions

- Reference [Dimensional Drawings on page 15](#).

Fixture Weight

- 28.6 Kg (63 lbs.)

Safety

- Minimum distance to flammable objects - 0.5 m (1.64 ft.)
- Minimum distance to lighted objects - 1.5 m (4.9 ft.)



CAUTION: RISK OF LED RADIATION. Do not stare into the beam.

Environment

- Ambient temperature - 0-45° C (32-114°F)
- Storage temperature - -20° - 60° C (0-140°F)

Compliance

- CE
- ETL file number 3104374
 - conforms to UL standard 1573
 - certified to CSA standard C22.2, NO:166

Mounting Options

- The SolaFrame 750 can be truss mounted using the provided mounting brackets and truss clamps (not provided).
- The SolaFrame 750 can be used upright, on a stable surface.

DMX Control

The SolaFrame 750 fixture operates on standard DMX512 control bus, controlled by a DMX console. A SolaFrame 750 fixture requires 47 channels of DMX512. Attach the fixture to the control bus using a two-core, shielded cable with a 5-pin XLR connector (Belden 9729 is preferred).

Two XLR termination receptacles are available, one for connection of DMX Input, and one for DMX Out (used when daisy-chaining to additional fixtures on the DMX control bus).

DMX Connector Pinout

For DMX Input, the DMX cable must have a male XLR connector on one end of the cable. When daisy-chaining DMX, the other end of the cable must have a female XLR connector. Terminate the cable ends as indicated in the pinout graphic below.

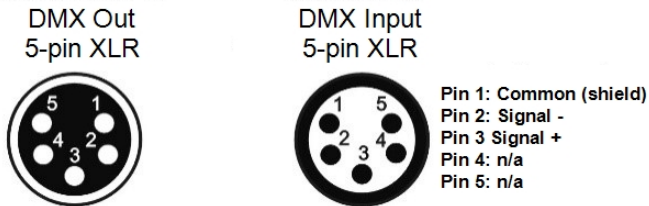

Terminate DMX512

For installations where there is a long DMX cable run, or is in an electrically noisy environment, it is recommended to use a DMX terminator or install a resistor on the last fixture of the DMX control run to prevent corruption (data reflection) of the digital control signal by electrical noise.

- A DMX terminator is an XLR plug with a 120 Ω resistor connected between pins 2 and 3, which can be installed into the DMX output receptacle of the last fixture in the DMX control run. This plug is available and sold separately. Contact your local High End dealer for ordering information.
- Alternatively, terminate the link by installing a 120 ohm, 1/4 watt (minimum) resistor in the fixture's Data Out (female) cable connector in the last fixture on each DMX control run.

Reference the graphics below:

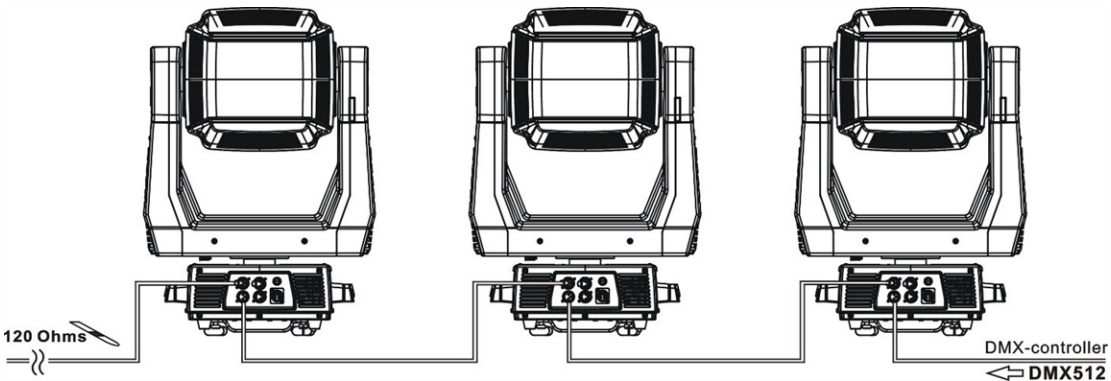

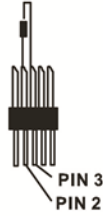
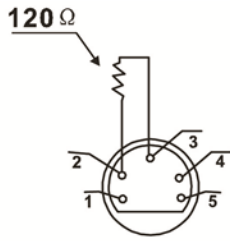

Installing a 120 Ω resistor into an XLR connector

1. Disassemble a male 5-pin XLR connector.
2. Solder a 120 Ω resistor, minimum 1/4 watt, between pin 2 and pin 3.
3. Reassemble the XLR connector.

Connect DMX Cables to Fixture

The following instructions are guidelines for connecting DMX to your fixture. Your installation may vary.

1. Connect the male XLR connector of a DMX data cable to the DMX Out connector on the DMX control source.
2. Connect the female XLR connector of the DMX data cable to the Data In connector of the first fixture on the DMX data control run.
3. Continue linking the remaining fixtures connecting a cable from the Data Out connector of each fixture to the Data In connector of the next fixture on the link.

DMX Start Address

All fixtures must be given a unique DMX starting address when using a DMX control signal, so that the correct fixture responds to the correct received control signals. This DMX start address is the channel number from which the fixture starts to “listen” to the digital control information sent out from the DMX control source.

Modify the fixture DMX start address on the user interface, located on the upper enclosure. See [Menu Settings and Programming on page 23](#).

If you set the same address, all the units will “listen” to the same control signal from the same channel number. In other words, changing the settings of one channel will affect all the fixtures simultaneously.

If you set a different address, each unit will start to “listen” to the channel number you have set, based on the quantity of control channels of the unit. That means changing the settings of one channel will affect only the selected fixture.

In the case of the moving head, which is a 47 channel fixture, you should set the starting address of the first unit to 1, the second unit to 48 ($47 + 1$), the third to 95 ($48 + 47$), and so on.

Menu Navigation and Overview

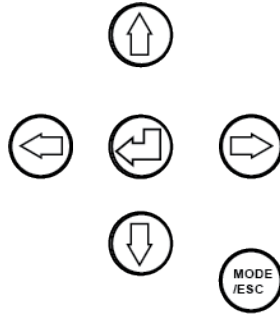

SolaFrame 750 fixtures can be programmed through the on board user interface and menu system. This section describes how to navigate the menu using the user interface buttons as well as provides an overview of the menu and the available settings for each selection.

Navigation



Note: The display is powered by battery when the fixture has no power. Press and hold the [MODE/ESC] button for three seconds to turn on the display using battery power.

When the fixture is powered on, and no data signal is present after one minute of time has lapsed, the display will switch off.

1. Press and hold the [MODE/ESC] button until the display flashes.
2. Browse the menu by pressing the up, down, left, or right navigation buttons.
3. Press the Enter button  to select a menu item.
4. Modify the selection by pressing the up, down, left, or right navigation buttons according to the selection.
5. Press the Enter button  to confirm a modified selection.



Note: 10 seconds after committing to a new mode or selection, and no further buttons are pressed, the unit will automatically return the display to the default display.

6. To exit the menu, press the [MODE/ESC] button.

Menu Settings and Programming

This section details instructions to configure and set up the SolaFrame 750 using the provided user interface and menu.



Note: The procedures below assume the fixture is powered.

Alternatively, when the fixture is not powered, the display is powered by battery. Press and hold the [MODE/ESC] button for three seconds to turn on the display using battery power.

Address

Address	A001~Axxx	DMX address setting
---------	-----------	---------------------

Set the starting DMX address.

1. Press the [MODE/ESC] button to display the main menu.
2. Tap the [Up] or [Down] button until the “Address” option displays, then press [Enter]. The display will show the Address menu with the current address (by default this is 001).
3. Tap the [Up] or [Down] button to change the starting DMX Address number.
4. Press [Enter] to confirm. The new address is set and the display returns to the main status screen. Alternatively, press [MODE/ESC] to return to the main menu without saving the address change.

Info

Info	Time Info.	Current Time Ttl Life Hrs Last Run Hrs LED Hours Timer PIN Clr Last Run LED Time PIN Clear LED Time	XXXX(Hours) XXXX(Hours) XXXX(Hours) XXXX(Hours) Password=XXX ON/OFF Password=XXX ON/OFF	Power on running time Fixture running time Fixture Last times clear LED running time Timer Password 038 Clear Fixture Last time LED Password ="038" Clear LED time
	Error Info	XXXXX		Show up to the minute error information
	DMX Value	All Control PAN.....		DMX value display
	Head Temp.	XXX°C/°F		Temperature in the head
	Fan Speed	1U01_BaseFAN1 :XX RPM 1U01_BaseFAN2 :XX RPM 4U01_SysFAN1 :XX RPM 4U01_SysFAN2 :XX RPM		Fan Speed
	Ethernet IP	Ethernet IP XXX.XXX.XXX.XXX XXX.XXX.XXX.XXX		IP information
	Software Ver	VerX.X.X.....		Software version

Time Info.

Current Time

This menu displays the running time of the fixture from the last power on. The current value is shown in hours (h). The counter resets after a power cycle.

1. Press the [MODE/ESC] button to display the main menu.
2. Tap the [Up] or [Down] button until the "Info" option displays, then press [Enter]. The "Info" menu displays.
3. Tap the [Up] or [Down] button until the "Time Info." option displays, then press [Enter]. The "Time Info" menu displays.
4. Tap the [Up] or [Down] button until the "Current Time" option displays, then press [Enter]. The current power on running time of the fixture displays. All time is shown in hours.
5. Press [Enter] or press the [MODE/ESC] button to return to the previous menu.

Ttl Life Hrs

This menu displays the total running time of the device. The current value is shown in hours (h).

1. Press the [MODE/ESC] button to display the main menu.
2. Tap the [Up] or [Down] button until the "Info" option displays, then press [Enter]. The "Info" menu displays.
3. Tap the [Up] or [Down] button until the "Time Info." option displays, then press [Enter]. The "Time Info" menu displays.
4. Tap the [Up] or [Down] button until the "Ttl Life Hrs" option displays, then press [Enter]. The accumulated fixture running time displays. All time is shown in hours.
5. Press [Enter] or press the [MODE/ESC] button to return to the previous menu.

Last Run Hrs

This menu displays the running time of the lamp from the last power. The current value is shown in hours (h).

1. Press the [MODE/ESC] button to display the main menu.
2. Tap the [Up] or [Down] button until the "Info" option displays, then press [Enter]. The "Info" menu displays.
3. Tap the [Up] or [Down] button until the "Time Info." option displays, then press [Enter]. The "Time Info" menu displays.
4. Tap the [Up] or [Down] button until the "Last Run Hrs" option displays, then press [Enter]. The lamp running time since the last power on displays. All time is shown in hours.
5. Press [Enter] or press the [MODE/ESC] button to return to the previous menu.

LED Hours

This menu displays the total running hours of the fixture LEDs. The current value is shown in hours (h).

1. Press the [MODE/ESC] button to display the main menu.
2. Tap the [Up] or [Down] button until the "Info" option displays, then press [Enter]. The "Info" menu displays.
3. Tap the [Up] or [Down] button until the "Time Info." option displays, then press [Enter]. The "Time Info" menu displays.
4. Tap the [Up] or [Down] button until the "LED Hrs" option displays, then press [Enter]. The accumulated time that LED's in the fixture have emitted light displays. All time is shown in hours.
5. Press [Enter] or press the [MODE/ESC] button to return to the previous menu.

Timer PIN

This menu displays and allows you to set the timer password. The default Timer PIN is "038".

1. Press the [MODE/ESC] button to display the main menu.
2. Tap the [Up] or [Down] button until the "Info" option displays, then press [Enter]. The "Info" menu displays.
3. Tap the [Up] or [Down] button until the "Time Info." option displays, then press [Enter]. The "Time Info" menu displays.
4. Tap the [Up] or [Down] button until the "Timer PIN" option displays, then press [Enter]. The "Timer PIN" menu displays.
5. Tap the [Up] or [Down] button to change the pin value. The default PIN code is "038".
6. Press [Enter] to apply a change or press the [MODE/ESC] button to return to the previous menu.

Clr Last Run

This menu is protected by password, accessible only when the Timer PIN has been provided in the previous menu. When accessed, this menu enables you to clear the last run time of the fixture.

1. Press the [MODE/ESC] button to display the main menu.
2. Tap the [Up] or [Down] button until the "Info" option displays, then press [Enter]. The "Info" menu displays.
3. Tap the [Up] or [Down] button until the "Time Info." option displays, then press [Enter]. The "Time Info" menu displays.
4. Tap the [Up] or [Down] button until the "Clr Last Run" option displays, then press [Enter].
5. Press the [Up] or [Down] button to change the setting to either Yes or No.
6. Press [Enter] to apply a change or press the [MODE/ESC] button to return to the previous menu.

LED Time PIN

This menu displays and allows you to set the LED time password. The default LED Time PIN is "038".

1. Press the [MODE/ESC] button to display the main menu.
2. Tap the [Up] or [Down] button until the "Info" option displays, then press [Enter]. The "Info" menu displays.
3. Tap the [Up] or [Down] button until the "Time Info." option displays, then press [Enter]. The "Time Info" menu displays.
4. Tap the [Up] or [Down] button until the "LED Timer PIN" option displays, then press [Enter]. The "LED Time PIN" menu displays.
5. Tap the [Up] or [Down] button to change the pin value. The default PIN code is "038".
6. Press [Enter] to apply a change or press the [MODE/ESC] button to return to the previous menu.

Clear LED Time

This menu is protected by password, accessible only when the LED Timer PIN has been provided in the previous menu. When accessed, this menu enables you to clear the last run time of the fixtures LED timer.

1. Press the [MODE/ESC] button to display the main menu.
2. Tap the [Up] or [Down] button until the "Info" option displays, then press [Enter]. The "Info" menu displays.
3. Tap the [Up] or [Down] button until the "Time Info." option displays, then press [Enter]. The "Time Info" menu displays.
4. Tap the [Up] or [Down] button until the "Clear LED Time" option displays, then press [Enter].
5. Press the [Up] or [Down] button to change the setting to either Yes or No.
6. Press [Enter] to apply a change or press the [MODE/ESC] button to return to the previous menu.

Error Info

This menu displays all discovered errors related to the fixture.

1. Press the [MODE/ESC] button to display the main menu.
2. Tap the [Up] or [Down] button until the "Info" option displays, then press [Enter]. The "Info" menu displays.
3. Tap the [Up] or [Down] button until the "Error Info." option displays, then press [Enter]. The current fixture errors display.
4. Press [Enter] or press the [MODE/ESC] button to return to the previous menu.

DMX Value

This menu displays the DMX value of each of the fixture's channels and allows you to change a DMX value for a channel (parameter of the fixture).

1. Press the [MODE/ESC] button to display the main menu.
2. Tap the [Up] or [Down] button until the "Info" option displays, then press [Enter]. The "Info" menu displays.
3. Tap the [Up] or [Down] button until the "DMX Value" option displays, then press [Enter]. The DMX Value settings menu displays.
4. Tap the [Up] or [Down] button to cycle through the available channels (All, Pan, Tilt, etc.), then press [Enter] to modify a selection. The current address displays for the selected channel.
5. Press the [Up] or [Down] button to edit the address setting.
6. Press [Enter] to apply a change or press the [MODE/ESC] button to return to the previous menu.

Head Temp

This menu displays the current fixture temperature as read from the fixture head (near the CMY filter).

1. Press the [MODE/ESC] button to display the main menu.
2. Tap the [Up] or [Down] button until the "Info" option displays, then press [Enter]. The "Info" menu displays.
3. Tap the [Up] or [Down] button until the "Head Temp" option displays, then press [Enter]. The current tem-

perature is shown in Celsius by default. To change the scale to °F, reference the Set>Temp. C/F menu.

4. Press [Enter] or press the [MODE/ESC] button to return to the previous menu.

Fan Speed

This menu displays the speed of the fixture's fans. Values are shown in RPM.

1. Press the [MODE/ESC] button to display the main menu.
2. Tap the [Up] or [Down] button until the "Info" option displays, then press [Enter]. The "Info" menu displays.
3. Tap the [Up] or [Down] button until the "Fan Speed" option displays, then press [Enter]. Each of the four fixture fans in the fixture are displayed with their current speed (in RPM's).
4. Press [Enter] or press the [MODE/ESC] button to return to the previous menu.

Ethernet IP

This menu displays the current set fixture IP address information.

1. Press the [MODE/ESC] button to display the main menu.
2. Tap the [Up] or [Down] button until the "Info" option displays, then press [Enter]. The "Info" menu displays.
3. Tap the [Up] or [Down] button until the "Ethernet IP" option displays, then press [Enter]. The current fixture Ethernet IP address information is shown.
4. Press [Enter] or press the [MODE/ESC] button to return to the previous menu.

Software Ver

This menu displays the current software version for the fixture.

1. Press the [MODE/ESC] button to display the main menu.
2. Tap the [Up] or [Down] button until the "Info" option displays, then press [Enter]. The "Info" menu displays.
3. Tap the [Up] or [Down] button until the "Software Ver" option displays, then press [Enter]. The current fixture software version is shown.
4. Press [Enter] or press the [MODE/ESC] button to return to the previous menu.

Set

Set	Status	No DMX Mode Pan Reverse Tilt Reverse Pan Degree Encoders Pan/Tilt Spd Hibernation Defogger	Close/ Hold /Auto ON/ OFF ON/ OFF 630/ 540 ON/ OFF Speed1~4 OFF, 01M~99M, Defog OnOP Defog Off Defog OnPwr	Auto run if no DMX Pan Reverse movement Tilt Reverse movement Pan Degree Select Movement Feedback Movement Mode Select Stand by Mode On when LEDs are above 0% intensity Disabled Always on when powered
	Select Input	DMX Only Art-Net On IP2 Art-Net On IP10 sACN		DMX Only Art-Net On IP2 Art-Net On IP10 sACN
	Set Universe	000~255		Set Art-Net Universe
	Service Setting	Service PIN Ethernet IP Ether Mask IP Clr Err Info	Password=XXX XXX. XXX. XXX. XXX XXX. XXX. XXX. XXX ON/ OFF	Service Password="050" Ethernet IP Ether Mask IP Clear Err information
	Fans Mode Setting	Standard Studio Continuous		Standard Studio Continuous
	Disp. Setting	Shutoff Time Flip Display Key Lock	02~60m 05m ON/ OFF ON/ OFF	Display shutoff time Reverse 180 degree Key Lock
	Temp. C/F	Fahrenheit Celsius		Temperature switch between °C/°F
	ResetDefault	ON/ OFF		Restore factory set.

Status

No DMX Mode

This menu sets the function of the fixtures control when no DMX signal is present. Options include auto , close, hold, and music. The default mode is hold.

1. Press the [MODE/ESC] button to display the main menu.
2. Tap the [Up] or [Down] button until the "Set" option displays, then press [Enter]. The "Set" menu displays.
3. Tap the [Up] or [Down] button until the "Status" option displays, then press [Enter]. The "Status" menu displays.
4. Press the [Up] or [Down] button until "No DMX Mode" displays, then press [Enter]. The current fixture control mode is shown.
5. Press [Up] or [Down] to modify the selection to a different mode.
6. Press [Enter] to commit to the change or press the [MODE/ESC] button to return to the previous menu.

Pan Reverse

This menu provides access to reverse the fixture's pan movement.

1. Press the [MODE/ESC] button to display the main menu.
2. Tap the [Up] or [Down] button until the "Set" option displays, then press [Enter]. The "Set" menu displays.
3. Tap the [Up] or [Down] button until the "Status" option displays, then press [Enter]. The "Status" menu displays.
4. Press the [Up] or [Down] button until "Pan Reverse" displays, then press [Enter]. The current setting for pan reverse displays (default setting is "Off").
5. Press [Up] or [Down] to modify the selection.
6. Press [Enter] to commit to the change or press the [MODE/ESC] button to return to the previous menu.

Tilt Reverse

This menu provides access to reverse the fixture's tilt movement.

1. Press the [MODE/ESC] button to display the main menu.
2. Tap the [Up] or [Down] button until the "Set" option displays, then press [Enter]. The "Set" menu displays.
3. Tap the [Up] or [Down] button until the "Status" option displays, then press [Enter]. The "Status" menu displays.
4. Press the [Up] or [Down] button until "Tilt Reverse" displays, then press [Enter]. The current setting for tilt reverse displays (default setting is "Off").
5. Press [Up] or [Down] to modify the selection.
6. Press [Enter] to commit to the change or press the [MODE/ESC] button to return to the previous menu.

Pan Degree

This menu provides access to change the fixtures pan rotation from its default 540 degrees to 630 degrees.

1. Press the [MODE/ESC] button to display the main menu.
2. Tap the [Up] or [Down] button until the "Set" option displays, then press [Enter]. The "Set" menu displays.
3. Tap the [Up] or [Down] button until the "Status" option displays, then press [Enter]. The "Status" menu displays.
4. Press the [Up] or [Down] button until "Pan Degree" displays, then press [Enter]. The current setting for pan degree displays (default setting is "540").
5. Press [Up] or [Down] to modify the selection.
6. Press [Enter] to commit to the change or press the [MODE/ESC] button to return to the previous menu.

Encoders

This menu provides access to switch encoder feedback for pan and tilt movement.

1. Press the [MODE/ESC] button to display the main menu.
2. Tap the [Up] or [Down] button until the "Set" option displays, then press [Enter]. The "Set" menu displays.
3. Tap the [Up] or [Down] button until the "Status" option displays, then press [Enter]. The "Status" menu displays.
4. Press the [Up] or [Down] button until "Encoders" displays, then press [Enter]. The current setting for feedback displays (default setting is "On").
5. Press [Up] or [Down] to modify the selection.
6. Press [Enter] to commit to the change or press the [MODE/ESC] button to return to the previous menu.

Pan/Tilt Spd

This menu provides access to change the speed (scan mode) of pan and tilt movement.

1. Press the [MODE/ESC] button to display the main menu.
2. Tap the [Up] or [Down] button until the "Set" option displays, then press [Enter]. The "Set" menu displays.
3. Tap the [Up] or [Down] button until the "Status" option displays, then press [Enter]. The "Status" menu displays.
4. Press the [Up] or [Down] button until "Pan/Tilt Spd" displays, then press [Enter]. The current speed setting displays.
5. Press [Up] or [Down] to modify the selection.
6. Press [Enter] to commit to the change or press the [MODE/ESC] button to return to the previous menu.

Hibernation - Standby mode

Hibernation mode forces the LEDs and stepper motors to power off when the fixture loses DMX control signal for a set period of time. The default time setting is 15 minutes.

1. Press the [MODE/ESC] button to display the main menu.
2. Tap the [Up] or [Down] button until the "Set" option displays, then press [Enter]. The "Set" menu displays.
3. Tap the [Up] or [Down] button until the "Status" option displays, then press [Enter]. The "Status" menu displays.
4. Press the [Up] or [Down] button until "Hibernation" displays, then press [Enter]. The current setting displays. The default setting is "15 minutes").
5. Press [Up] or [Down] to modify the selection(1 - 99 minutes or set the mode to "Off").
6. Press [Enter] to commit to the change or press the [MODE/ESC] button to return to the previous menu.

Defogger

1. Press the [MODE/ESC] button to display the main menu.
2. Tap the [Up] or [Down] button until the "Set" option displays, then press [Enter]. The "Set" menu displays.
3. Tap the [Up] or [Down] button until the "Status" option displays then press [Enter]. The "Status" menu displays.
4. Press the [Up] or [Down] button until "Defogger" displays, then press [Enter]. The current setting displays. The default setting is "Defog OnOP" which means the defogger is enabled when the LEDs are above 0% intensity.
5. Press [Up] or [Down] to modify the selection. Options include "Defog OnOP" (when LEDs are above 0% intensity), "Defog OnPwr" (always heating front lens when powered), and "Defog Off" (defogger is disabled).
6. Press [Enter] to commit to the change or press the [MODE/ESC] button to return to the previous menu.

Select Input

Set the control input for the fixture.

1. Press the [MODE/ESC] button to display the main menu.
2. Tap the [Up] or [Down] button until the "Set" option displays, then press [Enter]. The "Set" menu displays.
3. Tap the [Up] or [Down] button until the "Select Input" option displays, then press [Enter]. The "Select Input" menu displays.
4. Press [Up] or [Down] to modify the selection (options include "DMX Only", "Art-Net On IP2". "Art-Net On IP10", or "sACN").
5. Press [Enter] to commit to the change or press the [MODE/ESC] button to return to the previous menu.

Set Universe

1. Press the [MODE/ESC] button to display the main menu.
2. Tap the [Up] or [Down] button until the "Set" option displays, then press [Enter]. The "Set" menu displays.
3. Tap the [Up] or [Down] button until the "Select Universe" option displays, then press [Enter]. The "Select Input" menu displays.
4. Press [Up] or [Down] to modify the selection (000 - 255).
5. Press [Enter] to commit to the change or press the [MODE/ESC] button to return to the previous menu.

Service Setting

The settings in the "Service Setting" menu are password protected. You must enter the Service PIN first, then additional menu settings will be accessible.

Service PIN

The Service PIN is "050".

RDM UID

Remote Device Management, or RDM, requires that all RDM devices have a unique identifier (UID) that consists of the manufacturer ID and serial number. Modifying this setting can break the RDM capability of this fixture.

There cannot be duplicate RDM UID on the same DMX control run as this will result in a data collision, causing a communication failure. Ensure that all fixtures have a unique RDM UID if RDM functionality is to be used.



Note: If DMX splitters are used and RDM control is to be used, these splitters must support RDM.

1. Press the [MODE/ESC] button to display the main menu.
2. Tap the [Up] or [Down] button until the "Set" option displays, then press [Enter]. The "Set" menu displays.
3. Tap the [Up] or [Down] button until the "Service Setting" option displays, then press [Enter]. The "Service Setting" menu displays.
4. Press the [Up] or [Down] button until "RDM UID" displays, then press [Enter]. If the Service PIN has not been correctly applied in the previous menu, this menu will not be accessible. With successful Service PIN entered, the current settings, manufacturer ID and fixture serial number, displays.
5. Press [Up] or [Down] to modify the fixture serial number to another setting. Do not duplicate RDM UID's in a system as this will prevent the system from responding to RDM commands.
6. Press [Enter] to commit to the change or press the [MODE/ESC] button to return to the previous menu.

Ethernet IP

1. Press the [MODE/ESC] button to display the main menu.
2. Tap the [Up] or [Down] button until the "Set" option displays, then press [Enter]. The "Set" menu displays.
3. Tap the [Up] or [Down] button until the "Service Setting" option displays, then press [Enter]. The "Service Setting" menu displays.
4. Press the [Up] or [Down] button until "Ethernet IP" displays, then press [Enter]. If the Service PIN has not been correctly applied in the previous menu, this menu will not be accessible. With successful Service PIN entered, the current IP settings will display. The default IP address is 002-142.058.034 with the last octet (034) selected for edit.
5. Use the [Left] or [Right] buttons to change the octet selected, and press the [Up] or [Down] button to

modify the selected number to another setting.

6. Press [Enter] to commit to the change or press the [MODE/ESC] button to return to the previous menu.

Ether MaskIP (Subnet Mask)

1. Press the [MODE/ESC] button to display the main menu.
2. Tap the [Up] or [Down] button until the "Set" option displays, then press [Enter]. The "Set" menu displays.
3. Tap the [Up] or [Down] button until the "Service Setting" option displays, then press [Enter]. The "Service Settings" menu displays.
4. Press the [Up] or [Down] button until "Ether MaskIP" displays, then press [Enter]. If the Service PIN has not been correctly applied in the previous menu, this menu will not be accessible. With successful Service PIN entered, the current IP Subnet mask settings will display. The default Subnet mask address is 255-000.000.000 with the last octet (000) selected for edit.
5. Use the [Left] or [Right] buttons to change the octet selected, and press the [Up] or [Down] button to modify the selected number to another setting.
6. Press [Enter] to commit to the change or press the [MODE/ESC] button to return to the previous menu.

Clr Err Info

1. Press the [MODE/ESC] button to display the main menu.
2. Tap the [Up] or [Down] button until the "Set" option displays, then press [Enter]. The "Set" menu displays.
3. Tap the [Up] or [Down] button until the "Service Setting" option displays, then press [Enter]. The "Service Settings" menu displays.
4. Press the [Up] or [Down] button until "Clr Err Info" displays, then press [Enter]. If the Service PIN has not been correctly applied in the previous menu, this menu will not be accessible. With successful Service PIN entered, the current setting will display. Off is the default setting.
5. Use the [Up] or [Down] buttons to change the selection.
6. Press [Enter] to commit to the change or press the [MODE/ESC] button to return to the previous menu.

Fans Mode Setting

1. Press the [MODE/ESC] button to display the main menu.
2. Tap the [Up] or [Down] button until the "Set" option displays, then press [Enter]. The "Set" menu displays.
3. Tap the [Up] or [Down] button until the "Fans Mode Setting" option displays, then press [Enter]. The "Fans Mode Set" menu displays.
4. Use the [Up] or [Down] buttons to modify the setting ("Standard", "Studio", or "Continuous").
5. Press [Enter] to commit to the change or press the [MODE/ESC] button to return to the previous menu.

Disp. Setting

This menu provides user setting for the display features.

Shutoff Time

This menu sets the amount of time after the last user interface button press until the display goes to sleep. By default, this setting is 5 minutes.

1. Press the [MODE/ESC] button to display the main menu.
2. Tap the [Up] or [Down] button until the "Set" option displays, then press [Enter]. The "Set" menu displays.
3. Tap the [Up] or [Down] button until the "Disp. Setting" option displays, then press [Enter]. The "Disp. Settings" menu displays.
4. Press the [Up] or [Down] button until "Shutoff Time" displays, then press [Enter]. The current shut off time displays. By default this setting is 5 minutes.

5. Use the [Up] or [Down] buttons to modify the selection (2 - 60 minutes).
6. Press [Enter] to commit to the change or press the [MODE/ESC] button to return to the previous menu.

Flip Display

This menu enables the display to be rotated 180°. Used for best user experience in a vertical installation.

1. Press the [MODE/ESC] button to display the main menu.
2. Tap the [Up] or [Down] button until the "Set" option displays, then press [Enter]. The "Set" menu displays.
3. Tap the [Up] or [Down] button until the "Disp. Setting" option displays, then press [Enter]. The "Disp. Settings" menu displays.
4. Press the [Up] or [Down] button until "Flip Display" displays, then press [Enter]. The current setting displays. By default this setting is set to "OFF".
5. Use the [Up] or [Down] buttons to modify the selection (ON will reverse the display 180° from a current OFF setting).
6. Press [Enter] to commit to the change or press the [MODE/ESC] button to return to the previous menu.

Key Lock

This menu activates the automatic key lock feature, locking the user interface buttons from activity.

1. Press the [MODE/ESC] button to display the main menu.
2. Tap the [Up] or [Down] button until the "Set" option displays, then press [Enter]. The "Set" menu displays.
3. Tap the [Up] or [Down] button until the "Disp. Setting" option displays, then press [Enter]. The "Disp. Settings" menu displays.
4. Press the [Up] or [Down] button until "Key Lock" displays, then press [Enter]. The current setting displays. By default this setting is set to "OFF".
5. Use the [Up] or [Down] buttons to modify the selection. When active, set to ON, the keys will be locked automatically after exiting edit mode.
6. Press [Enter] to commit to the change or press the [MODE/ESC] button to return to the previous menu.



Note: To enable the user interface buttons again after enabling the key lock feature, press and hold the [MODE/ESC] button for three seconds.

Temp. C/F

This menu provides settings for the temperature scale.

1. Press the [MODE/ESC] button to display the main menu.
2. Tap the [Up] or [Down] button until the "Set" option displays, then press [Enter]. The "Set" menu displays.
3. Tap the [Up] or [Down] button until the "Temp. C/F" option displays, then press [Enter]. The "Temp C/F" menu displays and the current setting. "Celsius" is the default setting.
4. Use the [Up] or [Down] buttons to modify the selection.
5. Press [Enter] to commit to the change or press the [MODE/ESC] button to return to the previous menu.

ResetDefault

This menu resets the fixture settings to the factory defaults.

1. Press the [MODE/ESC] button to display the main menu.
2. Tap the [Up] or [Down] button until the "Set" option displays, then press [Enter]. The "Set" menu displays.

3. Tap the [Up] or [Down] button until the "ResetDefault" option displays, then press [Enter]. The "ResetDefault" menu displays.
4. Use the [Up] or [Down] buttons to modify the selection.
5. Press [Enter] to commit to the change. When set to ON, the unit will reset to factory defaults, and return the display to the default status screen. To exit without saving the change, press the [MODE/ESC] button to return to the previous menu.

Test Menu

Test	Home	All Pan&Tilt Colors Gobos Others	Reset All Reset Pan&Tilt Reset Colors Reset Gobos Reset Others
	Self Test		Self Test
	Test Channel	Control PAN Coarse.....	Test function
	Manual Ctrl.	Control =XXX :	Fine adjustment of the LED
	Calibration	-Password- Pan Coarse=XXX :	Password "050" Calbrate and adjust the effects to standard/right position

Home

This menu provides access to re-home the fixture or its mechanical features.

1. Press the [MODE/ESC] button to display the main menu.
2. Tap the [Up] or [Down] button until the "Test" option displays, then press [Enter]. The "Test" menu displays.
3. Tap the [Up] or [Down] button until the "Home" option displays, then press [Enter]. The "Home" menu displays.
4. Use the [Up] or [Down] buttons to modify the selection ("All" (all features in the fixture will re-home), "Pan&Tilt" (re-homes only the pan and tilt), "Colors", "Gobos", and "Others", etc.).
5. Press [Enter] to commit to the change or press the [MODE/ESC] button to return to the previous menu.

Self Test

This menu provides access to run a self test program on the fixture.

1. Press the [MODE/ESC] button to display the main menu.
2. Tap the [Up] or [Down] button until the "Test" option displays, then press [Enter]. The "Test" menu displays.
3. Tap the [Up] or [Down] button until the "Self Test" option displays, then press [Enter]. The "Self Test" menu displays and shows "Running" and the fixture will automatically begin a self test procedure, testing each of the functions. This display will remain until the [MODE/ESC] button is pressed, which will return the display to the previous menu.

Test Channel

This menu provides access to automatically run a self test on each fixture channel individually.

1. Press the [MODE/ESC] button to display the main menu.
2. Tap the [Up] or [Down] button until the "Test" option displays, then press [Enter]. The "Test" menu displays.
3. Tap the [Up] or [Down] button until the "Test Channel" option displays, then press [Enter]. The "Test Channel" menu displays with "Control" begin the first channel selected. The fixture automatically begins a self test procedure for the extents of the fixture control features.
4. Press the [Up] or [Down] button to cycle through all fixture channels individually. As each channel is selected, the test will automatically begin for the displayed channel.
5. Press the [MODE/ESC] button to exit the "Test Channel" mode and return the display to the previous menu.

Manual Ctrl.

This menu provides access to manually set each fixture channel value individually.

1. Press the [MODE/ESC] button to display the main menu.
2. Tap the [Up] or [Down] button until the "Test" option displays, then press [Enter]. The "Test" menu displays.
3. Tap the [Up] or [Down] button until the "Manual Ctrl." option displays, then press [Enter]. The "Manual Ctrl" menu displays.
4. Press the [Up] or [Down] button to cycle through the available fixture channels, and press [Enter] to select. The selected fixture channel displays with the default channel value.
5. Press the [Up] or [Down] button to modify the value (000 - 255).
6. Press [Enter] to select the new value and return to the "Manual Ctrl" menu.
7. Press the [MODE/ESC] button to exit "Manual Ctrl." menu and return the display to the previous menu.

Calibration

This menu provides access to adjust the fixture's calibration features, modifying the home position. The calibration menu password is "050". This password must be supplied first, then the additional calibration menus will be accessible.

1. Press the [MODE/ESC] button to display the main menu.
2. Tap the [Up] or [Down] button until the "Test" option displays, then press [Enter]. The "Test" menu displays.
3. Tap the [Up] or [Down] button until the "Calibration" option displays, then press [Enter]. The "Calibration" menu displays.
4. Press [Enter] to select "Password" and use the [Up] button to select "050", then press [Enter]. The display returns to the previous menu.
5. Press the [Up] or [Down] button to cycle through all available calibration features and press [Enter] to select. The selection displays with the default channel value.
6. Press the [Up] or [Down] button to modify the value and press [Enter] to select and return to the "Calibration" menu.
7. Press the [MODE/ESC] button to exit the "Calibration" menu and return the display to the previous menu.

Preset

Preset	PlayBack	DMX Control Set To Slave Auto Program	Slave1,Slave2,Slave3 Master / Alone	Choose DMX mode Slave setting Auto program
	Select Prog.	Prog. Part 1 = Program 1 ~ 10 Prog. Part 2 = Program 1 ~ 10 Prog. Part 3 = Program 1 ~ 10	Program 1 Program 2 Program 3	Select programs to be run
	Edit Program	Program 1 : Program 10	Program Test Step 01=SCxxx Step 64=SCxxx	Testing program Program in loop Save and exit
	Edit Scenes	Scene 001 ~ Scene 250	Control,Pan Coarse,..... Fade Time Scene Time Input By Outside	Save and automatically return manual scenes edit
	Scenes Input	XX-XX		Automat. scenes rec

PlayBack

This menu is provided to set the fixture's playback settings. Playback settings designate a fixture for DMX Control, set to run an Auto Program as a master or in stand alone mode, or set for slave mode where playback information is received from a different master.

Preset programming requires one fixture to act as the Master. All other SolaFrame 750 fixtures on the link can then be set a slaves to playback the designated master's presets. Slave fixtures receive all their preset parameter and timing information from the master fixture.

Example: The following example shows the relationship between programs, partitions, and scenes as programmed on the Master and how slave fixtures are assigned.

Groups of scenes are edited into Programs 1– 10 on the fixture designated as Master

- Program 2 is assigned to Part 1
- Program 4 is assigned to Part 2
- Program 6 is assigned to Part 3

- * Fixtures assigned as Slave 1 will playback Part 1
- * Fixtures assigned as Slave 2 will playback Part 2
- * Fixtures assigned as Slave 3 will playback Part 3

1. Press the [MODE/ESC] button to display the main menu.
2. Tap the [Up] or [Down] button until the "Preset" option displays, then press [Enter]. The "Preset" menu displays.
3. Tap the [Up] or [Down] button until the "PlayBack" option displays, then press [Enter]. The "PlayBack" menu displays.
4. Press the [Up] or [Down] button to cycle through all available playback options (listed below). Press [Enter] to make the selection.
 - DMX Control - reverts the function from Auto Program to DMX receive. Selecting this option returns the display to the main status screen where DMX Receive will be displayed as the currently selected function.

- Set to Slave - after a preset program is defined on a Master fixture, other SolaFrame 750 fixtures on the same DMX data link can be designated slaves to playback the configured Program (Part 1, 2, or 3) as defined on the Master fixture.
 - Auto Program - sets the fixture to run an internal program alone or as a master. The program that runs is determined under the "Select Prog." menu.
5. Press [Enter] to select or press the [MODE/ESC] button to return the display to the previous menu.

Select Prog.

This menu is provided to select the auto program the fixture will run.

1. Press the [MODE/ESC] button to display the main menu.
2. Tap the [Up] or [Down] button until the "Preset" option displays, then press [Enter]. The "Preset" menu displays.
3. Tap the [Up] or [Down] button until the "Select Prog." option displays, then press [Enter]. The "Select Prog" menu displays.
4. Tap the [Up] or [Down] button to cycle through and select from the available program options (Prog. Part1, ... Part2, etc.), then press [Enter].
5. Press the [Up] or [Down] button to choose the Program to run for the selected part, then press [Enter]. The display returns to the main menu.

Edit Program

This menu is provided to edit the steps in the internal auto programs.

1. Press the [MODE/ESC] button to display the main menu.
2. Tap the [Up] or [Down] button until the "Preset" option displays, then press [Enter]. The "Preset" menu displays.
3. Tap the [Up] or [Down] button until the "Edit Program" option displays, then press [Enter]. The "Edit Program" menu displays.
4. Tap the [Up] or [Down] button to cycle through and select from the available program options (Program 1, Program 2, etc.), then press [Enter]. The "Edit Program" menu displays.
5. Press the [Up] or [Down] button to choose the first step to edit from the available options, then press [Enter].
6. Press the [Up] or [Down] button to select the program action from the available options, then press [Enter].
7. Repeat for each step if desired. Press [Enter] with each edit.
8. To return to the main menu, press the [MODE/ESC] button.

Edit Scenes

A parameter is a fixture attribute that can be controlled, for example to modify the light beam in terms of color, beam quality and pattern, intensity, or focus (position). DMX programming assigns a DMX value to each of the fixture's parameters. A scene is one combination of parameter settings. The SolaFrame 750 fixture provides 250 pre-programmed scenes you can use or edit to build a preset program.

This menu is provided to edit the scenes in the internal auto programs.

1. Press the [MODE/ESC] button to display the main menu.
2. Tap the [Up] or [Down] button until the "Preset" option displays, then press [Enter]. The "Preset" menu displays.
3. Tap the [Up] or [Down] button until the "Edit Scenes" option displays, then press [Enter]. The "Edit Scenes" menu displays.
4. Tap the [Up] or [Down] button to cycle through and select from the available scene options (Scene 1, Scene 2, etc.), then press [Enter]. The "Edit Scenes" menu displays and the fixture responds to the selected scene.
5. Press the [Up] or [Down] button to scroll the available channel feature and press [Enter]. The channel value displays for edit.
6. Press the [Up] or [Down] button to change the channel value, then press [Enter].
7. Repeat for each scene if desired. Press [Enter] with each edit.
8. To return to the main menu, press the [MODE/ESC] button.

Scenes Input

This menu allows you to capture scene data, overwriting fixture attribute DMX parameter values, from a DMX control source.

1. Press the [MODE/ESC] button to display the main menu.
2. Tap the [Up] or [Down] button until the "Preset" option displays, then press [Enter]. The "Preset" menu displays.
3. Tap the [Up] or [Down] button until the "Scenes Input" option displays, then press [Enter]. The "Scenes Input" menu displays.
4. Press the [Up] or [Down] button to select the start scene number and the [Left] or [Right] button to select the end scene number. With each change of any DMX value, as received by the DMX control source, the capturing scene will advance to the next one in the range.
5. When all scenes have been recorded, the display will return to the main menu.



Note: While capturing the DMX data from the control source, the SolaFrame 750 does not playback the DMX input, it only captures the data into the on-board memory. You must edit or playback the scene after recording to verify the results. Best practice is to prepare the scenes on a DMX controller with a zero crossfade for all parameters between each step. Remember that any change of a DMX value will automatically advance to the next scene for capturing.

DMX Control Protocol

The most current DMX Control Protocol data for the SolaFrame 750 can be found on the High End Systems, Inc. website <https://www.highend.com/SolaFrame750-DMXProtocol>.

The following data is current as of protocol version 1.00

Standard Protocol	
Channel	Construct
1	Pan Coarse
2	Pan Fine
3	Tilt Coarse
4	Tilt Fine
5	Color Mix Function
6	Cyan
7	Magenta
8	Yellow
9	CTO
10	Static Color Function
11	Static Color Position
12	Gobo 1 Function
13	Gobo 1 Position
14	Gobo 1 Rotate Function
15	Gobo 1 Rotate Coarse
16	Gobo 1 Rotate Fine
17	Blade 1 Angle A
18	Blade 1 Angle B
19	Blade 2 Angle A
20	Blade 2 Angle B
21	Blade 3 Angle A
22	Blade 3 Angle B
23	Blade 4 Angle A
24	Blade 4 Angle B
25	Frame Rotation Coarse
26	Frame Rotation Fine
27	Animation Function
28	Prism Function
29	Prism Rotate Coarse
30	Prism Rotate Fine
31	Frost
32	Focus Coarse
33	Focus Fine
34	Zoom Coarse
35	Zoom Fine
36	Auto Focus
37	AutoFocus Fine
38	Iris
39	Shutter/LED Function
40	Shutter/LED
41	Dim Coarse
42	Dim Fine
43	LED Animations
44	LED Animation Speed
45	LED Animation Xfade
46	Mspeed
47	Control

Channel	Marketing Construct	Description	Decimal Low	Decimal High	Percent Low	Percent High	Hex Low	Hex High	Controller Defaults	
1	Pan	Pan Coarse	0	255	0%	100%	00h	FFh	127	
2	Pan	Pan Fine	0	255	0%	100%	00h	FFh	255	
3	Tilt	Tilt Coarse	0	255	0%	100%	00h	FFh	127	
4	Tilt	Tilt Fine	0	255	0%	100%	00h	FFh	255	
5	Color Mix Function	Pure Mix	0	31	0%	12%	00h	1Fh	0	
		Cycle	32	47	13%	18%	20h	2Fh		
		Random	48	63	19%	25%	30h	3Fh		
		Reserved	80	255	31%	100%	50h	FFh		
6 7 8	Cyan Magenta Yellow	Pure Mix							255	
		Full Saturation	0		100%		00h			
		Open	255		0%		FFh			
		Cycle & Random Modes. Scan Speed controlled by Cyan Channel								
9	CTO	Slow Rate	0		0%		00h		255	
		Fast Rate	255		100%		FFh			
		Full Saturation	0		0%		00h			
10	Static Color 1 Function	Open (White)	255		100%		FFh		48	
		Indexed	0	15	0%	6%	00h	0Fh		
		Forward Spin	16	31	6%	12%	10h	1Fh		
		Reverse Spin	32	47	13%	18%	20h	2Fh		
		Continuous (Note 1)	48	63	19%	25%	30h	3Fh		
		Fast Scan	64	79	25%	31%	40h	4Fh		
		Random	80	95	31%	37%	50h	5Fh		
Reserved	96	255	38%	100%	60h	FFh				
11	Static Color 1 Position	Indexed, Scan & Blink modes								0
		1. Open (White)	0	14	0%	5%	00h	0Eh		
		2. (Open/Red)	15	29	6%	11%	0Fh	1Dh		
		3. (Red)	30	44	12%	17%	1Eh	2Ch		
		4. (Red/Blue)	45	59	18%	23%	2Dh	3Bh		
		5. (Blue)	60	74	24%	29%	3Ch	4Ah		
		6. (Blue/Green)	75	89	29%	35%	4Bh	59h		
		7. (Green)	90	104	35%	41%	5Ah	68h		
		8. (Green/Yellow)	105	119	41%	47%	69h	77h		
		9. (Yellow)	120	134	47%	53%	78h	86h		
		10. (Yellow/Orange)	135	149	53%	58%	87h	95h		
		11. (Orange)	150	164	59%	64%	96h	A4h		
		12. (Orange/Purple)	165	179	65%	70%	A5h	B3h		
		13. (Purple)	180	194	71%	76%	B4h	C2h		
		14. (Purple/Dark Blue)	195	209	76%	82%	C3h	D1h		
		15. (Dark Blue)	210	224	82%	88%	D2h	E0h		
		16. (Dark Blue/Open)	225	239	88%	94%	E1h	EFh		
		1. Open (White)	240	255	94%	100%	F0h	FFh		
		Spin & Random modes								
		Stop	0		0%	0%	00h	00h		
Slowest to fastest	255		100%	0%	FFh	00h				
Continuous mode										
Positioning from 0-360 degrees	0	255	0%	100%	00h	FFh				

17	Blade 1 Angle A	Out of the light path	0		0%		00h		0
		Full in the light path	255		100%		FFh		
18	Blade 1 Angle B	Out of the light path	0		0%		00h		0
		Full in the light path	255		100%		FFh		
19	Blade 2 Angle A	Out of the light path	0		0%		00h		0
		Full in the light path	255		100%		FFh		
20	Blade 2 Angle B	Out of the light path	0		0%		00h		0
		Full in the light path	255		100%		FFh		
21	Blade 3 Angle A	Out of the light path	0		0%		00h		0
		Full in the light path	255		100%		FFh		
22	Blade 3 Angle B	Out of the light path	0		0%		00h		0
		Full in the light path	255		100%		FFh		
23	Blade 4 Angle A	Out of the light path	0		0%		00h		0
		Full in the light path	255		100%		FFh		
24	Blade 4 Angle B	Out of the light path	0		0%		00h		0
		Full in the light path	255		100%		FFh		
25	Frame Rotation Coarse	Frame Angle Negative	0	127	0%	50%	00h	7Fh	105
		Frame Angle 0 degrees	128		50%		80h		
		Frame Angle positive	129	255	51%	100%	81h	FFh	
26	Frame Rotation Fine	Frame Angle Negative	0	127	0%	50%	00h	7Fh	144
		Frame Angle 0 degrees	128		50%		80h		
		Frame Angle positive	129	255	51%	100%	81h	FFh	
27	Animation 1 Function	Disengaged	0	3	0%	1%	00h	03h	0
		Engaged, static	4	6	2%	2%	04h	06h	
		Engaged, motion stopped	7	8	3%	3%	07h	08h	
		Engaged, Forward Spin speed slow to fast	9	70	4%	27%	09h	46h	
		Engaged, Reverse Spin speed slow to fast	71	131	28%	51%	47h	83h	
		Engaged, Forward Strobe rotate slow to fast	132	193	52%	76%	84h	C1h	
		Engaged, Reverse Strobe Rotate slow to fast	194	255	76%	100%	C2h	FFh	
28	Prism Function	Disengaged	0	15	0%	6%	00h	0Fh	
		Continuous	16	31	6%	12%	10h	1Fh	
		Forward Spin	32	47	13%	18%	20h	2Fh	
		Reverse Spin	48	63	19%	25%	30h	3Fh	
		Forward Strobe Rotate (Effect animate)	64	79	25%	31%	40h	4Fh	
		Reverse Strobe Rotate (Effect animate)	80	95	31%	37%	50h	5Fh	
		Reserved	96	255	38%	100%	60h	FFh	
29	Prism Rotate Coarse	Continuous mode							127
		Position 0-360 degrees	0	255	0%	100%	00h	FFh	
		Forward/Reverse/Forward Strobe/Reverse Strobe Rotate Modes							
		Rotate Stop	0	3	0%	1%	00h	03h	
30	Prism Rotate Fine	Rotate Slowest to Fastest	4	255	2%	100%	04h	FFh	255
		Continuous mode							
31	Frost	Low Order Byte 0-360 degrees	0	255	0%	100%	00h	FFh	0
		Open (hard edge)	0		0%	0%	00h	00h	
		Variable edge hard to soft)	1	127	0%	50%	01h	7Fh	
		Soft Edge	128	135	50%	53%	80h	87h	
		Periodic strobe	136	151	53%	59%	88h	97h	
		Random strobe	152	167	60%	65%	98h	A7h	
32	Focus Coarse	Open (hard edge)	168	225	66%	88%	A8h	E1h	127
		Focus In	0		0%		00h		
33	Focus Fine	Focus Out	255		100%		FFh		255
		Focus In	0		0%		00h		
34	Zoom Coarse	Focus Out	255		100%		FFh		127
		Zoom In	0		0%		00h		
35	Zoom Fine	Zoom Out	255		100%		FFh		255
		Zoom In	0		0%		00h		
		Zoom Out	255		100%		FFh		
		Zoom In	0		0%		00h		

36	Auto Focus	Auto Focus Off	0	15	0%	6%	00h	0Fh	0	
		5m	16	31	6%	12%	10h	1Fh		
		7.5m	32	47	13%	18%	20h	2Fh		
		10m	48	255	19%	100%	30h	FFh		
37	Auto Focus Fine	Focus In Fine	0		0%		00h		0	
		Focus Out Fine	255		100%		FFh			
38	Iris	Iris Closed	0		0%		00h		255	
		Iris Open	255		100%		FFh			
39	Shutter/LED Functions	Normal Shutter Functions	0	31	0%	12%	00h	1Fh	0	
		Random Random strobe	32	63	13%	25%	20h	3Fh		
		Synchronous Random Strobe	64	95	25%	37%	40h	5Fh		
		Normal Shutter Functions	96	255	38%	100%	60h	FFh		
40	Shutter/LED	Normal/Random/Sync Random shutter functions.								
		Close	0	23	0%	9%	00h	17h	255	
		Strobe Rate (slow to fast)	24	229	9%	90%	18h	E5h		
		Open	230	255	90%	100%	E6h	FFh		
41	Dim Coarse	Close	0		0%		00h			0
		Open	255		100%		FFh			
42	Dim Fine		0		0%		00h		0	
			255		100%		FFh			
43	LED Animations (Note 2)	Macro off	0	3	0%	1%	00h	03h	0	
		Macro 1	4	7	2%	3%	04h	07h		
		Macro 2	8	11	3%	4%	08h	0Bh		
		Macro 3	12	15	5%	6%	0Ch	0Fh		
		Macro 4	16	19	6%	7%	10h	13h		
		Macro 5	20	23	8%	9%	14h	17h		
		...								
		Macro 15	60	63						
TBD	64	255	25%	100%	40h	FFh				
44	LED Animation Speed	Stop	0		0%	0%	00h	00h	128	
		Decreasing speed	1	127	0%	50%	01h	7Fh		
		Programmed speed x1	128				80h			
		Increasing speed	129	255	51%	100%	81h	FFh		
45	LED Animation X fade	Stop	0		0%		00h	00h	128	
		Decreasing speed	1	127	0%	50%	01h	7Fh		
		Programmed speed x1	128		50%		80h			
		Increasing speed	129	255	51%	100%	81h	FFh		
46	Mspeed	Disable	0	3	0%	1%	00h	03h	0	
		Longest (252.7 seconds)	4		2%		04h			
		Shortest (0.15 seconds)	255		100%		FFh			

		The Control channel should not be crossfaded. No shutter channel requirement.							
47	Control (Note 3)	Safe (normal operation)	0	9	0%	4%	00h	09h	0
		TBD	10	19	4%	7%	0Ah	13h	
		Display Off (send 20 packets)	20	28	8%	11%	14h	1Ch	
		Display On (send 20 packets)	29	35	11%	14%	1Dh	23h	
		TBD	36	48	14%	19%	24h	30h	
		Home All (send 20 packets)	49	68	19%	27%	31h	44h	
		Shutdown (send 80 packets)	69	75	27%	29%	45h	4Bh	
		Studio fan control mode (send 20 packets)	76	82	30%	32%	4Ch	52h	
		Continuous fan control mode (send 20 packets)	83	89	33%	35%	53h	59h	
		Standard fan control mode (send 20 packets)	90	96	35%	38%	5Ah	60h	
		Disable Pan/Tilt motors	97	103	38%	40%	61h	67h	
		TBD	104	130	41%	51%	68h	82h	
		Audio Sync	131	160	51%	63%	83h	A0h	
		Internal Prog 1 scene 1-8 EEPROM	161	171	63%	67%	A1h	ABh	
		Internal Prog 2 scene 9-16 EEPROM	172	182	67%	71%	ACH	B6h	
		Internal Prog 3 scene 17-24 EEPROM	183	193	72%	76%	B7h	C1h	
		Internal Prog 4 scene 25-32 EEPROM	194	204	76%	80%	C2h	CCh	
		Internal Prog 5 scene 33-40 EEPROM	205	215	80%	84%	CDh	D7h	
		Internal Prog 6 scene 41-48 EEPROM	216	226	85%	89%	D8h	E2h	
		Internal Prog 7 scene 49-56 EEPROM	227	237	89%	93%	E3h	EDh	
		TBD	238	255	93%	100%	Eeh	FFh	

Protocol Notes

- Continuous mode should take quickest path from 255-0, and 0-255.
 - Continuous mode color wheel aperture centers:

Color	Center of color DMX value
Open	0
Red	30
Blue	61
Green	94
Yellow	126
Orange	158
Purple	190
Dark Blue	221

- 15 Discrete multi-step LED animations. These require macro speed and x fade channels. The macros will operate independently. The X fade and speed channels act as multipliers of the programmed speed in the discrete macro steps.
 - Speed / X fade channel operation
 - 0 stops playback or crossfade
 - 1-127 decreases playback speed / crossfade time (* <1)
 - 128 playback or cross fade speed is as programmed (*1)
 - 129-255 increases playback speed / crossfade time (* >1)

Error Codes

When you turn on the fixture, it will complete a start-up procedure.

Example: For example, when the display shows “Err Info: Pan Movement”, it means there is an error in channel 1. When multiple errors are present they will cycle on the display twice, then the fixture will generate a second reset. Any errors that remain after two reset cycles are not correctable by reset alone and will require service. Please contact support if detailed assistance is needed.

Pan movement

This message displays after the reset of the fixture if any of the following conditions exist:

- if the yoke's magnetic-indexing circuit malfunctions (optical or magnetic sensor failure)
- if the stepper motor is defective or the related IC driver on the main PCB has failed
- if the Pan movement is not located in the default position after the reset

Tilt movement

This message displays after the reset of the fixture if any of the following conditions exist:

- if the fixture head magnetic-indexing circuit malfunctions (optical or magnetic sensor failure)
- if the stepper motor is defective or the related IC driver on the main PCB has failed
- if the Tilt movement is not located in the default position after the reset

Color1

This message displays after the reset of the fixture if any of the following conditions exist:

- if the fixture head's magnetic-indexing circuit malfunctions (optical or magnetic sensor failure)
- if the stepper motor is defective or the related IC driver on the main PCB has failed
- if the Color wheel movement is not located in the default position after the reset

Cyan, Magenta, or Yellow Color

This message displays after the reset of the fixture if any of the following conditions exist:

- if the fixture head's magnetic-indexing circuit malfunctions (optical or magnetic sensor failure)
- if the stepper motor is defective or the related IC driver on the main PCB has failed
- if the CMY movement is not located in the default position after the reset

CTO Color

This message displays after the reset of the fixture if any of the following conditions exist:

- if the fixture head's magnetic-indexing circuit malfunctions (optical or magnetic sensor failure)
- if the stepper motor is defective or the related IC driver on the main PCB has failed
- if the CTO movement is not located in the default position after the reset

Gobo1

This message displays after the reset of the fixture if any of the following conditions exist:

- if the magnetic-indexing circuit malfunctions (optical or magnetic sensor failure)
- if the stepper motor is defective or the related IC driver on the main PCB has failed
- if Gobo Wheel 1 is not located in the default position after the reset

Gobo1Rot

This message displays after the reset of the fixture if any of the following conditions exist:

- if the magnetic-indexing circuit malfunctions (optical or magnetic sensor failure)
- if the stepper motor is defective or the related IC driver on the main PCB has failed
- if Gobo Rotating Wheel 1 is not located in the default position after the reset

Focus

This message displays after the reset of the fixture if any of the following conditions exist:

- if the magnetic-indexing circuit malfunctions (optical or magnetic sensor failure)
- if the stepper motor is defective or the related IC driver on the main PCB has failed
- if the Focus movement is not located in the default position after the reset

Zoom

This message displays after the reset of the fixture if any of the following conditions exist:

- if the magnetic-indexing circuit malfunctions (optical or magnetic sensor failure)
- if the stepper motor is defective or the related IC driver on the main PCB has failed
- if the Zoom movement is not located in the default position after the reset

Frost

This message displays after the reset of the fixture if any of the following conditions exist:

- if the magnetic-indexing circuit malfunctions (optical or magnetic sensor failure)
- if the stepper motor is defective or the related IC driver on the main PCB has failed
- if the Frost movement is not located in the default position after the reset

Animation1

This message displays after the reset of the fixture if any of the following conditions exist:

- if the magnetic-indexing circuit malfunctions (optical or magnetic sensor failure)
- if the stepper motor is defective or the related IC driver on the main PCB has failed
- if the Animation movement is not located in the default position after the reset

Blade1

This message displays after the reset of the fixture if any of the following conditions exist:

- if the magnetic-indexing circuit malfunctions (optical or magnetic sensor failure)
- if the stepper motor is defective or the related IC driver on the main PCB has failed
- if the Blade Rotation movement is not located in the default position after the reset

Cleaning and Maintenance

The following must be considered during regular service and inspection:

- All screws for installing the device or parts of the device must be tightly connected and must not be corroded.
- There must not be any deformations to the housing, lenses, rigging, and installation points (ceiling, suspension, trussing).
- Motorized parts must not show any signs of wear and must move smoothly without issue.
- The power supply cables must not show any damage, material fatigue or sediment.



Note: Further instructions depending on the installation location and usage must be adhered to by a qualified installer and all safety concerns must be mitigated.



CAUTION: Disconnect the fixture from mains power before starting any maintenance procedures.

In order to ensure the device remains in good working condition and does not fail prematurely, regular maintenance is recommended.

1. Clean the inside and outside lens regularly to avoid loss of output due to accumulation of dust/ dirt on the lens.
2. Clean the fans regularly to ensure maximum airflow and efficient thermal cooling. This will ensure the light source is operated in the best possible condition.



Note: ETC and High End Systems, Inc. recommends frequent cleaning of the device. Please use a moist, lint-free cloth. Never use alcohol or solvents.

If spare parts are required, order only genuine parts from your local authorized dealer.

HIGH END SYSTEMS



an ETC. Company

Headquarters • 2105 Gracy Farms Lane, Austin, TX, 75758 USA

Tel +512 836 2242 • Fax +512 837 5290 • 24 Hour Urgent Support: +512 836 2242

Web: highend.com • © 2017 Electronic Theatre Controls, Inc.

Product information and specifications subject to change. ETC intends this document to be provided in its entirety.

SolaFrame 750 User Manual • Rev A • Released 2017-10