



KRAMER ELECTRONICS LTD.

# USER MANUAL

MODEL:

**FC-46xI**  
HDMI Audio De-Embedder

---

P/N: 2900-000626 Rev 8



## FC-46xl Quick Start Guide

This guide helps you install and use your product for the first time. For more detailed information, go to [http://www.kramerelectronics.com/support/product\\_downloads.asp](http://www.kramerelectronics.com/support/product_downloads.asp) to download the latest manual or scan the QR code on the left.

### Step 1: Check what's in the box

- ✓ **FC-46xl** HDMI Audio De-embedder
- ✓ 1 Power supply (5V DC)

- ✓ 4 Rubber feet
- ✓ 1 Quick start guide

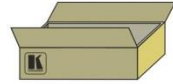

Save the original box and packaging materials in case you need to return your **FC-46xl** for service.

### Step 2: Install the Machine

Attach the rubber feet and place on a table or mount the **FC-46xl** in a rack (using an optional **RK-3T** rack adapter).

### Step 3: Connect the inputs and outputs

Always switch off the power on each device before connecting it to your **FC-46xl**.

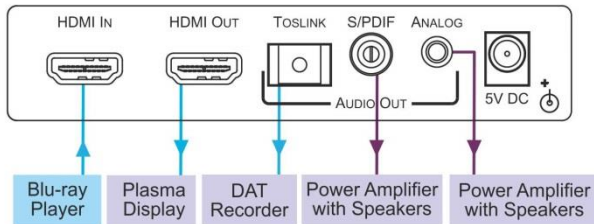

Always use Kramer high-performance cables for connecting AV equipment to the **FC-46xl**.

### Step 4: Connect the power

Connect the 5V DC power adapter to the **FC-46xl** and plug the adapter into the mains electricity.



### Step 5: Operate the FC-46xl

Select the audio source:  
the HDMI input or output.



# Contents

<b>1</b>	<b>Introduction</b>	<b>1</b>
<b>2</b>	<b>Getting Started</b>	<b>2</b>
2.1	Achieving the Best Performance	2
2.2	Recycling Kramer Products	3
<b>3</b>	<b>Overview</b>	<b>4</b>
<b>4</b>	<b>Defining the FC-46xl</b>	<b>5</b>
<b>5</b>	<b>Connecting the FC-46xl</b>	<b>6</b>
<b>6</b>	<b>Technical Specifications</b>	<b>8</b>

## Figures

Figure 1:	FC-46xl HDMI Audio De-Embedder	5
Figure 2:	Connecting the FC-46xl HDMI Audio De-Embedder	7

---

# 1 Introduction

Welcome to Kramer Electronics! Since 1981, Kramer Electronics has been providing a world of unique, creative, and affordable solutions to the vast range of problems that confront the video, audio, presentation, and broadcasting professional on a daily basis. In recent years, we have redesigned and upgraded most of our line, making the best even better!

Our 1,000-plus different models now appear in 11 groups that are clearly defined by function: GROUP 1: Distribution Amplifiers; GROUP 2: Switchers and Routers; GROUP 3: Control Systems; GROUP 4: Format/Standards Converters; GROUP 5: Range Extenders and Repeaters; GROUP 6: Specialty AV Products; GROUP 7: Scan Converters and Scalers; GROUP 8: Cables and Connectors; GROUP 9: Room Connectivity; GROUP 10: Accessories and Rack Adapters and GROUP 11: Sierra Products.

Congratulations on purchasing your Kramer **FC-46xI HDMI Audio De-Embedder**, which is ideal for the following typical applications:

- Home theater, presentation and multimedia applications
- Rental and staging

---

## 2 Getting Started

We recommend that you:

- Unpack the equipment carefully and save the original box and packaging materials for possible future shipment
- Review the contents of this user manual



Go to [http://www.kramerelectronics.com/support/product\\_downloads.asp](http://www.kramerelectronics.com/support/product_downloads.asp) to check for up-to-date user manuals, application programs, and to check if firmware upgrades are available (where appropriate).

### 2.1 Achieving the Best Performance

To achieve the best performance:

- Use only good quality connection cables (we recommend Kramer high-performance, high-resolution cables) to avoid interference, deterioration in signal quality due to poor matching, and elevated noise levels (often associated with low quality cables)
- Do not secure the cables in tight bundles or roll the slack into tight coils
- Avoid interference from neighboring electrical appliances that may adversely influence signal quality
- Position your Kramer **FC-46xl** away from moisture, excessive sunlight and dust



This equipment is to be used only inside a building. It may only be connected to other equipment that is installed inside a building.



**Caution:** No operator serviceable parts inside the unit

**Warning:** Use only the Kramer Electronics input power wall adapter that is provided with the unit

**Warning:** Disconnect the power and unplug the unit from the wall before installing

## 2.2 Recycling Kramer Products

The Waste Electrical and Electronic Equipment (WEEE) Directive 2002/96/EC aims to reduce the amount of WEEE sent for disposal to landfill or incineration by requiring it to be collected and recycled. To comply with the WEEE Directive, Kramer Electronics has made arrangements with the European Advanced Recycling Network (EARN) and will cover any costs of treatment, recycling and recovery of waste Kramer Electronics branded equipment on arrival at the EARN facility. For details of Kramer's recycling arrangements in your particular country go to our recycling pages at <http://www.kramerelectronics.com/support/recycling/>.

---

## 3 Overview

The **FC-46xl** is a high-performance HDMI audio de-embedder. The unit de-embeds audio from the HDMI input or from the HDMI output Audio Return Channel to S/PDIF, TOSLINK® and analog audio outputs simultaneously.

The **FC-46xl** lets you connect your HDMI source to an HDMI display and enjoy high-quality digital audio at the same time (for example, when using a high-quality AV receiver).



When there are more than two channels of audio (for example, 5.1), the audio is available only on the digital outputs and the analog output is disabled.

In particular, the **FC-46xl** features:

- A maximum data rate of 6.75Gbps (2.25Gbps per data channel)
- HDTV compatibility with support for resolutions up to 1080p@60Hz
- HDCP compliance
- Kramer re-Klocking™ and Equalization Technology – Rebuilds the digital signal to travel longer distances.
- HDMI support for ARC and HDMI uncompressed audio channels
- Input format auto detection; digital RGB or YPbPr
- Support for deep color up to 36 bits per pixel at 1080p
- I-EDIDPro™ Kramer Intelligent EDID Processing™ an Intelligent EDID handling and processing algorithm that ensures Plug and Play operation for HDMI systems
- 5V DC power

## 4 Defining the FC-46xl

Figure 1 defines the **FC-46xl HDMI Audio De-Embedder**.

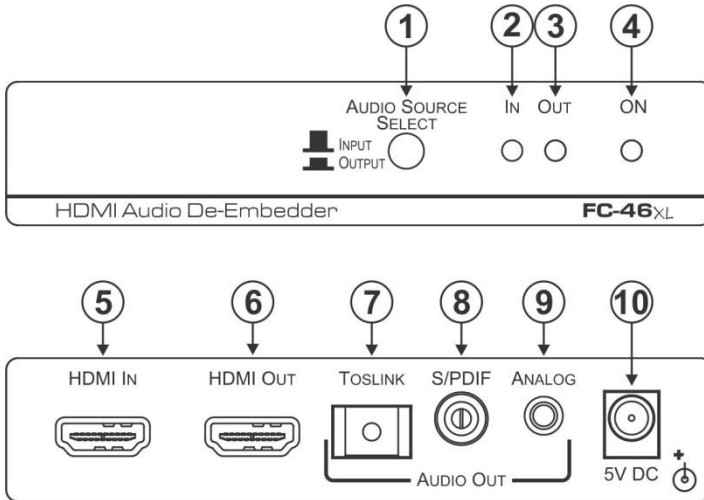

Figure 1: FC-46xl HDMI Audio De-Embedder

#	Feature		Function
1	AUDIO SOURCE SELECT Button	INPUT	Release to select audio from HDMI IN
		OUTPUT	Press in to select audio from HDMI OUT TV audio return signal
2	IN LED		Lights to indicate signal presence at HDMI IN
3	OUT LED		Lights to indicate that an acceptor is connected to HDMI OUT
4	ON LED		Lights when the unit is powered on
5	HDMI IN Connector		Connect to the HDMI source
6	HDMI OUT Connector		Connect to the HDMI acceptor
7	TOSLINK Connector	AUDIO OUT	Connect to the digital audio acceptor
8	S/PDIF RCA Connector		
9	ANALOG 3.5 Mini Connector		
10	5V DC		+5V DC connector for powering the unit, center positive



---

## 5 Connecting the FC-46xl



Always switch off the power to each device before connecting it to your **FC-46xl**. After connecting your **FC-46xl**, connect its power and then switch on the power to each device.

To connect the **FC-46xl** as illustrated in the example in [Figure 2](#):

1. Connect the HDMI source (for example, a Blu-ray disc player) to the HDMI IN connector.
2. Connect the HDMI OUT connector to the HDMI acceptor (for example, a plasma display).
3. Connect the audio output(s) to the digital/analog audio acceptor(s), for example, power amplifier(s) or active speaker(s).



The analog audio output is disabled when there are more than two channels (for example, 5.1) on the audio input.

4. Using the AUDIO SOURCE SELECT button, select the audio source to be either the HDMI input (button released, audio is taken from the Blu-ray Disc), or the HDMI output (button pressed in, audio is taken from the TV audio return signal).
5. Connect the 5V DC power adapter to the power socket and connect the adapter to the mains electricity (not illustrated in [Figure 2](#)).

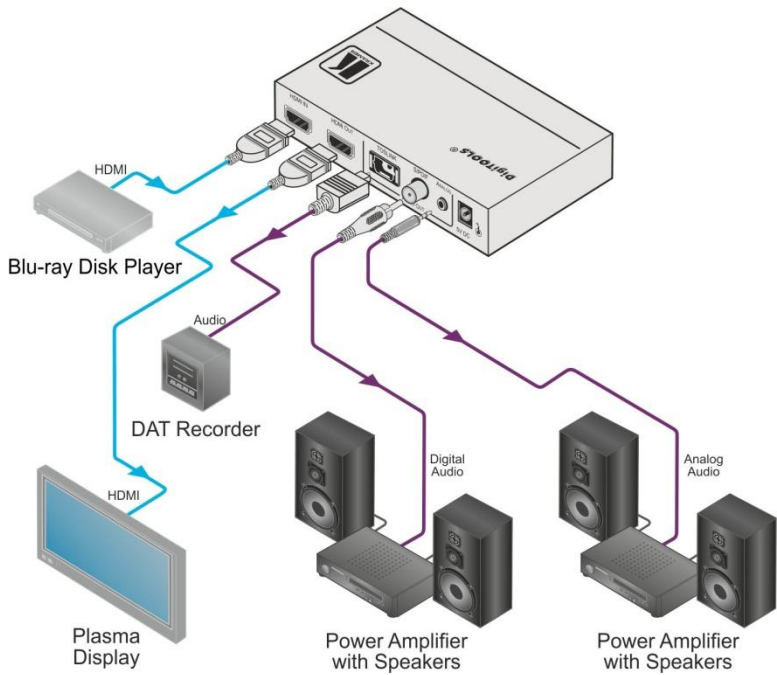

Figure 2: Connecting the FC-46xl HDMI Audio De-Embedder

## 6 Technical Specifications

INPUT:	HDMI connector
OUTPUTS:	1 HDMI connector 1 TOSLINK® optical digital audio connector 1 S/PDIF digital audio on an RCA connector 1 Analog audio on a 3.5 mm mini connector
OPERATION FREQUENCY:	Supports up to 6.75Gbps (2.25Gbps per graphic channel) 1080p @60Hz, 36-bit Deep Color
COMPLIANCE WITH HDMI STANDARD:	Supports HDMI, HDCP
CONTROLS:	Audio Source Select button
INDICATOR LEADS:	ON, IN, OUT
POWER SOURCE:	5V DC, 730mA
OPERATING TEMPERATURE:	0° to +40°C (32° to 104°F)
STORAGE TEMPERATURE:	-40° to +70°C (-40° to 158°F)
HUMIDITY:	10% to 90%, RHL non-condensing
DIMENSIONS:	12.4cm x 7cm x 2.4cm (4.9" x 2.8" x 0.94") W, D, H
WEIGHT:	0.4kg (0.88lbs) approx.
INCLUDED ACCESSORIES:	Power supply
OPTIONS:	Kramer 10-Port Universal 5V Power Supply VA-100P-5 RK-3T 19" rack adapter
Specifications are subject to change without notice at <a href="http://www.kramerelectronics.com">http://www.kramerelectronics.com</a>	

## LIMITED WARRANTY

The warranty obligations of Kramer Electronics for this product are limited to the terms set forth below:

### What is Covered

This limited warranty covers defects in materials and workmanship in this product.

### What is Not Covered

This limited warranty does not cover any damage, deterioration or malfunction resulting from any alteration, modification, improper or unreasonable use or maintenance, misuse, abuse, accident, neglect, exposure to excess moisture, fire, improper packing and shipping (such claims must be presented to the carrier), lightning, power surges, or other acts of nature. This limited warranty does not cover any damage, deterioration or malfunction resulting from the installation or removal of this product from any installation, any unauthorized tampering with this product, any repairs attempted by anyone unauthorized by Kramer Electronics to make such repairs, or any other cause which does not relate directly to a defect in materials and/or workmanship of this product. This limited warranty does not cover cartons, equipment enclosures, cables or accessories used in conjunction with this product.

Without limiting any other exclusion herein, Kramer Electronics does not warrant that the product covered hereby, including, without limitation, the technology and/or integrated circuit(s) included in the product, will not become obsolete or that such items are or will remain compatible with any other product or technology with which the product may be used.

### How Long Does this Coverage Last

Seven years as of this printing; please check our Web site for the most current and accurate warranty information.

### Who is Covered

Only the original purchaser of this product is covered under this limited warranty. This limited warranty is not transferable to subsequent purchasers or owners of this product.

### What Kramer Electronics will do

Kramer Electronics will, at its sole option, provide one of the following three remedies to whatever extent it shall deem necessary to satisfy a proper claim under this limited warranty:

1. Elect to repair or facilitate the repair of any defective parts within a reasonable period of time, free of any charge for the necessary parts and labor to complete the repair and restore this product to its proper operating condition. Kramer Electronics will also pay the shipping costs necessary to return this product once the repair is complete.
2. Replace this product with a direct replacement or with a similar product deemed by Kramer Electronics to perform substantially the same function as the original product.
3. Issue a refund of the original purchase price less depreciation to be determined based on the age of the product at the time remedy is sought under this limited warranty.

### What Kramer Electronics will not do Under This Limited Warranty

If this product is returned to Kramer Electronics or the authorized dealer from which it was purchased or any other party authorized to repair Kramer Electronics products, this product must be insured during shipment, with the insurance and shipping charges prepaid by you. If this product is returned uninsured, you assume all risks of loss or damage during shipment. Kramer Electronics will not be responsible for any costs related to the removal or re-installation of this product from or into any installation. Kramer Electronics will not be responsible for any costs related to any setting up this product, any adjustment of user controls or any programming required for a specific installation of this product.

### How to Obtain a Remedy under this Limited Warranty

To obtain a remedy under this limited warranty, you must contact either the authorized Kramer Electronics reseller from whom you purchased this product or the Kramer Electronics office nearest you. For a list of authorized Kramer Electronics resellers and/or Kramer Electronics authorized service providers, please visit our web site at [www.kramerelectronics.com](http://www.kramerelectronics.com) or contact the Kramer Electronics office nearest you.

In order to pursue any remedy under this limited warranty, you must possess an original, dated receipt as proof of purchase from an authorized Kramer Electronics reseller. If this product is returned under this limited warranty, a return authorization number, obtained from Kramer Electronics, will be required. You may also be directed to an authorized reseller or a person authorized by Kramer Electronics to repair the product.

If it is decided that this product should be returned directly to Kramer Electronics, this product should be properly packed, preferably in the original carton, for shipping. Cartons not bearing a return authorization number will be refused.

### Limitation on Liability

THE MAXIMUM LIABILITY OF KRAMER ELECTRONICS UNDER THIS LIMITED WARRANTY SHALL NOT EXCEED THE ACTUAL PURCHASE PRICE PAID FOR THE PRODUCT. TO THE MAXIMUM EXTENT PERMITTED BY LAW, KRAMER ELECTRONICS IS NOT RESPONSIBLE FOR DIRECT, SPECIAL, INCIDENTAL OR CONSEQUENTIAL DAMAGES RESULTING FROM ANY BREACH OF WARRANTY OR CONDITION, OR UNDER ANY OTHER LEGAL THEORY. Some countries, districts or states do not allow the exclusion or limitation of relief, special, incidental, consequential or indirect damages, or the limitation of liability to specified amounts, so the above limitations or exclusions may not apply to you.

### Exclusive Remedy

TO THE MAXIMUM EXTENT PERMITTED BY LAW, THIS LIMITED WARRANTY AND THE REMEDIES SET FORTH ABOVE ARE EXCLUSIVE AND IN LIEU OF ALL OTHER WARRANTIES, REMEDIES AND CONDITIONS, WHETHER ORAL OR WRITTEN, EXPRESS OR IMPLIED. TO THE MAXIMUM EXTENT PERMITTED BY LAW, KRAMER ELECTRONICS SPECIFICALLY DISCLAIMS ANY AND ALL IMPLIED WARRANTIES, INCLUDING, WITHOUT LIMITATION, WARRANTIES OF MERCHANTABILITY AND FITNESS FOR A PARTICULAR PURPOSE. IF KRAMER ELECTRONICS CANNOT LAWFULLY DISCLAIM OR EXCLUDE IMPLIED WARRANTIES UNDER APPLICABLE LAW, THEN ALL IMPLIED WARRANTIES COVERING THIS PRODUCT, INCLUDING WARRANTIES OF MERCHANTABILITY AND FITNESS FOR A PARTICULAR PURPOSE, SHALL APPLY TO THIS PRODUCT AS PROVIDED UNDER APPLICABLE LAW.

IF ANY PRODUCT TO WHICH THIS LIMITED WARRANTY APPLIES IS A "CONSUMER PRODUCT" UNDER THE MAGNUSON-MOSS WARRANTY ACT (15 U.S.C.A. §2301, ET SEQ.) OR OTHER APPLICABLE LAW, THE FOREGOING DISCLAIMER OF IMPLIED WARRANTIES SHALL NOT APPLY TO YOU, AND ALL IMPLIED WARRANTIES ON THIS PRODUCT, INCLUDING WARRANTIES OF MERCHANTABILITY AND FITNESS FOR THE PARTICULAR PURPOSE, SHALL APPLY AS PROVIDED UNDER APPLICABLE LAW.

### Other Conditions

This limited warranty gives you specific legal rights, and you may have other rights which vary from country to country or state to state.

This limited warranty is void if (i) the label bearing the serial number of this product has been removed or defaced, (ii) the product is not distributed by Kramer Electronics or (iii) this product is not purchased from an authorized Kramer Electronics reseller. If you are unsure whether a reseller is an authorized Kramer Electronics reseller, please visit our Web site at [www.kramerelectronics.com](http://www.kramerelectronics.com) or contact a Kramer Electronics office from the list at the end of this document.

Your rights under this limited warranty are not diminished if you do not complete and return the product registration form or complete and submit the online product registration form. Kramer Electronics thanks you for purchasing a Kramer Electronics product. We hope it will give you years of satisfaction.



For the latest information on our products and a list of Kramer distributors, visit our Web site where updates to this user manual may be found.

**We welcome your questions, comments, and feedback.**

Web site: [www.kramerelectronics.com](http://www.kramerelectronics.com)

E-mail: [info@kramerel.com](mailto:info@kramerel.com)

CE



**SAFETY WARNING**

Disconnect the unit from the power supply before opening and servicing

P/N: 2900-000626



Rev: 8

